

TRUCK, AMBULANCE FRONT LINE, 1/4-TON, 4 x 4, M170
TRUCK, UTILITY 1/4-TON, 4 x 4, M38A1

| | <i>Page</i> |
|---|-------------|
| INTRODUCTION. | 2 |
| NOTES | 7 |
| GROUP 01 ENGINE. | 14 |
| GROUP 02 CLUTCH | 55 |
| GROUP 03 FUEL SYSTEM..... | 62 |
| GROUP 04 EXHAUST SYSTEM | 100 |
| GROUP 05 COOLING SYSTEM..... | 164 |
| GROUP 66 ELECTRICAL SYSTEM.. | 110 |
| GROUP 07 TRANSMISSION | 184 |
| GROUP 08 TRANSFER. | 195 |
| GROUP 09 PROPELLER SHAFT AND UNIVERSAL JOINTS | 205 |
| GROUP 10 FRONT AXLE | 209 |
| GROUP 11 REAR AXLE. | 223 |
| GROUP 12 BRAKES. | 232 |
| GROUP 13 WHEELS, HUBS, AND DRUMS..... | 250 |
| GROUP 14 CONTROLS..... | 253 |
| GROUP 15 FRAME AND BRACKETS | 263 |
| GROUP 16 SPRINGS AND SHOCK ABSORBERS | 274 |
| GROUP 17 FENDERS AND HOOD..... | 294 |
| GROUP 18 BODY. | 299 |
| GROUP 26 WINCH AND POWER-TAKE-OFF..... | 347 |
| GROUP 21 BUMPERS AND GUARDS. | 361 |
| GROUP 22 MISCELLANEOUS ACCESSORIES.. | 363 |
| ALPHABETICAL INDEX..... | 374 |
| ORDNANCE AND MANUFACTURER'S PART NUMBER INDEX..... | 394 |
| ORDNANCE STOCK NUMBER INDEX..... | 431 |
| FEDERAL STOCK NUMBER INDEX..... | 441 |

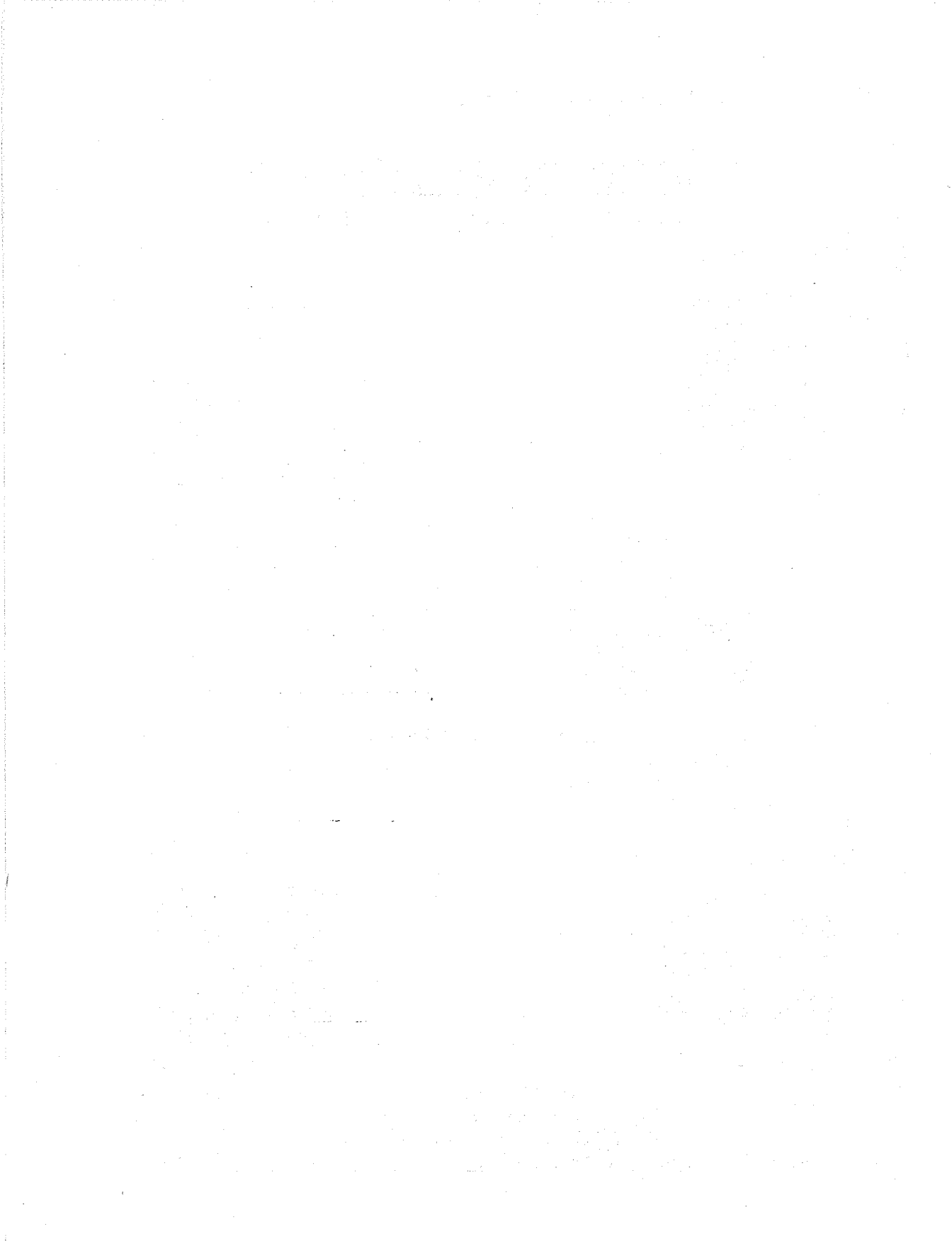

INTRODUCTION

1. GENERAL. a. This supply manual is an illustrated list of all service parts of the 1/4-ton 4 x 4 utility truck M38A1 and front line ambulance truck M170 arranged according to standard government grouping.

NOTE: Many of the parts listed herein are not stocked for issue. See ORD 7 and ORD 8 sections of this supply manual for listings of those parts stocked and authorized for issue to the various levels of maintenance. When parts not listed in the ORD 8 are needed, separate requisition for these parts should be forwarded through normal supply channels with justification therefor.

b. This list of all service parts is to be used for identification and storage purposes. Every individual part is not necessarily stored by itself; many parts are stored as authorized assemblies. Such assemblies are indicated herein. The components of such assemblies are listed alphabetically within the group, with the total quantity of each part required for that particular application.

c. The Federal stock number column lists the 11-digit Federal stock number (or the 7-digit Federal item identification number) which has been assigned by the Cataloging Division, Office of the Assistant Secretary of Defense (Supply and Logistics). These numbers are for information only and will not be used in connection with supply operations, until such time as implementation of the Federal Cataloging Program is accomplished, through editing action on appropriate supply documents (requisitions, issue slips, excess lists, etc).

d. Classification codes for Federal standard catalog numbers listed herein are published in the ORD 5-2 series.

e. For prices of items contained herein, see the appropriate supply manual of the ORD 5-3 series.

f. Additional applications of items in this manual are listed in the ORD 5-5 series.

g. An explanation of reference symbols used in this manual is included under NOTES.

h. For full information relative to the Ordnance section of the Department of the Army supply manual, including the purposes and uses, the procedure followed, and the principles employed in its compilation, see ORD 1, and for an index thereof, see DA Pam 310-29.

2. VEHICLE DESIGNATION. The 1/4-ton 4 x 4 utility truck M38A1 is designated as a general purpose vehicle; front line ambulance truck M170 is designated as a special equipment vehicle as defined in AR 700-105.

3. PERTINENT PUBLICATIONS. The following technical manuals pertain to these vehicles and components thereof: TM 9-8014, 9-8015-1, 9-8015-2, 9-8627, 9-1825B.

4. INTERCHANGEABILITY OF COMPONENTS. Several parts and accessories of the M38A1 engine are interchangeable with corresponding parts of the Ford Model GPW (SNL G-503) Willys Model MB and the M38 (SNL G-740). Several parts of the electrical system are interchangeable with other vehicles with 24-volt electrical systems.

5. SERIAL NUMBER LOCATIONS. Serial numbers for these vehicles are located as follows:

| | |
|----------------------|---|
| Complete vehicle | |
| 10001 and up..... | Stamped on name plate located on instrument panel. |
| Engine 10001 and up. | Stamped on water pump boss located on top of cylinder block, front end of engine. |

6. ILLUSTRATIONS. This supply manual contains illustrations to aid the user in locating and identifying parts. These are placed before each group for convenient reference with the text for that group. For each part identified on an illustration, the noun, part number, and group number is shown, but a note on the illustration will indicate that all parts are in a particular group (i.e., all parts are listed in group 0611). The prefix portion of the figure

number indicates the group to which it pertains; the suffix indicates the sequence number within that group (e.g., figure 07-5 signifies illustration number 5 for group 07).

7. COMPONENTS OF ASSEMBLIES. Whenever any doubt might exist as to what items are included as components of assemblies, an explanatory note or a complete listing of such components is shown.

8. ATTACHING PARTS. Attaching parts such as bolts, nuts, rivets, washers, etc., are indented immediately under the item which they attach. Whenever two or more similar items having the same attaching parts, such as right and left fender braces, are listed, they are placed one immediately following the other and the attaching parts for both are covered by a single listing under the second item.

9. DEFINITION OF LOCATIONAL TERMS. All like parts which are not interchangeable are designated *left* or *right* with respect to the vehicle when it is viewed facing forward from the rear of the vehicle. The front of the vehicle is the direction faced by the driver. All engine parts, *left* or *right*, *front* or *rear*, are designated from a position at the rear of the engine facing forward. The flywheel end is the rear of the engine.

10. DESCRIPTION. All items are listed with their complete nomenclature with the exception noted in *a.* below.

a. Items appearing within a subgroup that lists components of, and/or items related to only *one* assembly or subassembly automatically assume as part of their official nomenclature the title of the pertinent subgroup. (Example: "AXLE, float lever," is an entry in subgroup 0301. The complete nomenclature of the item is "AXLE, carburetor, float lever," "CARBURETOR" being the subgroup title.)

b. Items appearing within a subgroup that lists *more than one* assembly or *more than one* group of related items are listed with their complete nomenclature. (Example: "EXTENSION, exhaust pipe, w/BACKET" is an entry in subgroup 0401. The complete nomenclature of the item is as shown, the title of the subgroup being "MUFFLER AND EXHAUST PIPE.")

11. QUANTITY INCORPORATED IN UNIT. The quantity incorporated in unit column lists quantities for the following:

a. For vehicle parts which are not indented, the quantity indicates the number of these parts required for the particular use indicated. These quantities do *not* indicate the total quantities of the parts required for the major item since the part may be used in more than one subgroup.

b. For vehicle parts which are indented (attaching parts), the quantity indicates the number of these parts required to attach the item. These quantities do *not* indicate the total quantities of the attaching parts required for the major item or subgroup, since the attaching parts may be used in more than one subgroup, and may also be used more than once within a subgroup.

12. HOW TO FIND PARTS. This supply manual is arranged and cross-indexed so that parts can be found easily even though only one of the several identifying factors is known. The various ways in which parts can be located are as follows:

a. If only the nomenclature (basic noun-name) is known, refer to the alphabetical index in the back of the manual. This index will give the subgroup in which the part is listed. As the part names are arranged in alphabetical order within this subgroup, the complete listing of the part can readily be found.

b. If any one of the numbers — ordnance stock, federal stock, manufacturer's or ordnance part is known, refer to the appropriate numerical index in the back of the manual. These indexes will give the subgroup number in which the part can be found by following the procedure given in *a.* above.

c. If the shape, use, function, or location of the part is known, refer to illustrations in which the part is likely to appear until a picture of the part is found. The part will be keyed to a listing of the name, part number, and subgroup number, which will permit locating the complete listing of the part.

13. STOCK NUMBERS. The prefix letter and number of the stock number (i.e., G503,

G740, G741, etc.) usually signifies that the particular part or component was originally coded under the major item designation for that SNL and does *not* mean that the part is used *only* in that major item. All subsequent supply manuals for different items will include the same stock number for this same part.

14. STANDARD GOVERNMENT GROUPING. The parts in this manual are arranged by groups and subgroups and are listed alphabetically within these subgroups. Parts are grouped primarily on the basis of their function rather than location. This arrangement facilitates identification and selection of parts. Refer to paragraph 12, "HOW TO FIND PARTS."

01—ENGINE

| | |
|--------|---|
| 0100.1 | Power Plant Assembly |
| 0100.2 | Engine Assembly |
| 0101 | Cylinder Block and Head |
| 0102.1 | Crankshaft |
| 0102.2 | Main Bearings |
| 0103 | Flywheel and Ring Gear |
| 0104.1 | Pistons and Piston Rings |
| 0104.2 | Connecting Rods and Bearings |
| 0105.1 | Valves, Springs, and Guides |
| 0105.2 | Push Rods, Rocker Arms, Tappets, and Covers |
| 0105.3 | Camshaft |
| 0105.5 | Camshaft Drive and Timing Gear Cover |
| 0106.1 | Oil Pump |
| 0106.2 | Oil Filter |
| 0106.5 | Crankcase Ventilator |
| 0106.6 | Oil Lines, Level Gage, and Oil Pan |
| 0108 | Exhaust Manifold |

02—CLUTCH

| | |
|------|-------------------------|
| 0201 | Disk and Pressure Plate |
| 0202 | Release and Controls |

03—FUEL SYSTEM

| | |
|--------|---|
| 0301 | Carburetor |
| 0302.1 | Fuel and Vacuum Pump |
| 0304.1 | Air Cleaner and Connections |
| 0304.5 | Underwater Vent System |
| 0306 | Fuel Tank and Lines |
| 0309 | Fuel Filter |
| 0312 | Accelerator, Hand Throttle, and Choke Control |

04—EXHAUST SYSTEM

| | |
|------|--------------------------|
| 0401 | Muffler and Exhaust Pipe |
|------|--------------------------|

05—COOLING SYSTEM

| | |
|------|-------------------------------------|
| 0501 | Radiator |
| 0502 | Radiator Air Deflectors and Shrouds |
| 0503 | Water Hoses and Thermostat |
| 0504 | Water Pump |
| 0505 | Fan Belts and Pulley |

06—ELECTRICAL SYSTEM

| | |
|--------|--------------------------------------|
| 0601.1 | Generator (24-Volt) (Auto-Lite) |
| 0601.3 | Generator (24-Volt) (Delco-Remy) |
| 0602 | Generator Regulator (24-Volt) |
| 0603 | Starter |
| 0604.1 | Distributor |
| 0605 | Ignition Coil Wiring and Spark Plugs |
| 0607 | Instrument Panel |
| 0608 | Miscellaneous Switches |
| 0609.1 | Head, Tail, and Marker Lights |
| 0609.2 | Auxiliary Lights (M170) |
| 0610 | Sending Units |
| 0611 | Horn |
| 0612 | Batteries and Cables |
| 0613.1 | Chassis Wiring |
| 0615 | Radio Suppression |
| 0617 | Trailer Coupling |

07—TRANSMISSION

| | |
|--------|---|
| 0700 | Transmission Assembly |
| 0701 | Case |
| 0702.1 | Input Shaft, Bearing, and Retainers |
| 0702.3 | Main Shaft, Gears, Bearings, and Synchronizer |
| 0702.5 | Countershaft, Idler Shaft, Gears, and Spacer |
| 0704 | Gear Shift, Lever, Shafts, and Forks |

08—TRANSFER

| | |
|--------|---|
| 0800 | Transfer Assembly |
| 0801 | Case and Covers |
| 0802.1 | Input Gear |
| 0802.3 | Countershaft |
| 0802.5 | Front Axle Output Shaft |
| 0802.7 | Rear Axle Output Shaft |
| 0804 | Shifter Shafts, Forks, and Gear Shift Hand Levers |

09—PROPELLER SHAFT AND UNIVERSAL JOINTS

| | |
|------|--------------------------------------|
| 0900 | Propeller Shaft and Universal Joints |
|------|--------------------------------------|

10—FRONT AXLE

| | |
|--------|----------------------------|
| 1000 | Front Axle Assembly |
| 1001 | Housing, Cover, and Plugs |
| 1002 | Differential |
| 1004 | Steering Knuckles |
| 1005.5 | Ventilation |
| 1006 | Shaft and Universal Joints |

11—REAR AXLE

| | |
|--------|---------------------------|
| 1100 | Rear Axle Assembly |
| 1101 | Housing, Cover, and Plugs |
| 1102 | Differential |
| 1104.1 | Shaft |
| 1105.5 | Ventilation |

12—BRAKES

| | |
|--------|------------------------|
| 1201 | Hand Brake |
| 1202 | Service Brakes |
| 1204.1 | Master Cylinder |
| 1204.3 | Wheel Cylinders |
| 1204.5 | Lines |
| 1206 | Pedals and Connections |

13—WHEELS, HUBS AND DRUMS

1311 Wheels, Hubs, and Drums
1313 Tires and Tubes

14—CONTROLS

1401 Steering Controls

15—FRAME AND BRACKETS

1501 Frame and Brackets
1503 Pintle and Towing Attachments
1504 Spare Wheel Carrier

16—SPRINGS AND SHOCK ABSORBERS

1601.1 Front Springs
1601.3 Rear Springs
1604.1 Shock Absorbers
1605 Stabilizer Bars (M170)

17—FENDERS AND HOOD

1701 Fenders and Aprons
1703 Hood

18—BODY

1800 Body Assembly
1801 Body Mounting Parts
1803.1 Tailgate
1804 Body Panels, Pillars, and Windshield
1805 Floor Pans and Access Panels
1806 Seats, Crash Pads, Trim, and Upholstery
1808 Stowage and Straps
1812 Special Purpose Body (M170)

20—WINCH AND POWER-TAKE-OFF

2001.1 Winch Assembly and Drum
2001.3 Winch Drive Shaft
2001.5 Winch Controls
2002.1 Power-Take-Off Assembly
2002.5 Power-Take-Off Controls

21—BUMPER AND GUARDS

2101 Bumpers and Guards

22—MISCELLANEOUS ACCESSORIES

2201 Canvas Items, Bows, and Curtains
2202 Mirrors, Reflectors, and Windshield Wipers
2208.1 Speedometer
2210 Vehicular Data Plates

15. ABBREVIATIONS.

adj adjust (ing), (able)
al aluminum
alloy-S alloy steel
amp ampere(s)
amp-hr ampere hour(s)
anld annealed
approx approximate(ly)
AR Army Regulations
AS American Standard
asb asbestos

assy assembly(ies)
AWG American Wire Gauge
b-hd button head
blk-enmld black enameled
blunt-pt blunt point
br brass
brg bearing
bz bronze
cd-pltd cadmium plated
CI cast iron
ck countersunk
cop copper
corr-res-S corrosion resistant steel
cp candle power
cr-pltd chrome plated
cup-pt cup point
DA Department of the Army
dble double
dble-tun-fil double tungsten filament
deg degree(s)
dia diameter
dld-hd drilled head
ea each
elec electric(al)
ext-teeth external teeth (lock washer)
fil-hd fillister head
fin finish(ing)
fl-hd flat head
ft foot (feet)
ga gage
gimlet-pt gimlet-point
glvd galvanized
hd head
hlds headless
header-pt header-point
hex hexagon(al)
hex-hd hexagon head
hv heavy
hyd hydraulic
ID inside diameter (dimension)
in inch(es)
incand incandescent
ins insulated, insulating, insulator
int-teeth internal teeth (lock washer)
ld-ctd lead coated
lg long (length)
LH left hand
lht left hand thread
lkg locking
lt light (weight)
M Model
mach machine
med medium
mfr's manufacturer's
MI malleable iron
MIL-STD-CODE Military Standard Code
min minimum, minute(s)
mm millimeter(s)
mtg mounting(s)
NC American National Coarse Thread

| | | | |
|--------------|--|---------------|------------------------------------|
| NEF | American National Extra Fine Thread | UNC | Unified Coarse Thread |
| NF | American National Fine Thread | UNF | Unified Fine Thread |
| ni-S | nickel steel | unfin | unfinished |
| No | number(s) | USS | United States Standard |
| NPT | American Standard Taper Pipe Thread | v | volt(s) |
| NPTF | American Standard Taper Pipe Thread (Dryseal) | w/ | with |
| NS | American National Special Thread | w/o | without |
| OD | outside diameter (dimension) | wtrprf | waterproofed |
| ORD | Ordinance (publication titles) | x | (by, in dimensions only, as 2 x 4) |
| oval-hd | oval head | zn | zinc |
| Pam | pamphlet | zn-dichromate | zinc dichromate |
| pan-hd | pan head | zn-pltd | zinc plated |
| phos-ctd | phosphate coated | | |
| pl | plain | | |
| pltd | plated | | |
| psi | pounds per square inch | | |
| pt | point, pint(s) | | |
| qty | quantity | | |
| rad | radius, radial | | |
| rd | round | | |
| rd-hd | round head | | |
| reg | regular | | |
| reqd | required | | |
| rf | radio frequency | | |
| RH | right hand | | |
| rht | right hand thread | | |
| ru | rubber | | |
| rvers | reverse(ible) | | |
| S | steel | | |
| SAE | Society of Automotive Engineers | | |
| sec | section | | |
| s-fin | semifinished | | |
| sgle | single | | |
| sgle-cond | single conductor | | |
| sgle-tun-fil | single tungsten filament | | |
| sh-met-thds | sheet metal thread(s) | | |
| sh-met | sheet metal | | |
| sld | slotted | | |
| SNL | Standard Nomenclature List | | |
| socket-hd | socket head | | |
| sp | special | | |
| spec | specification(s) | | |
| sq | square | | |
| sq-drive | square-drive | | |
| sq-hd | square head | | |
| sq-nk | square neck | | |
| sq-nut | square nut | | |
| sq-socket | square socket | | |
| SR | single-row | | |
| std | standard | | |
| stght | straight | | |
| stk | stock | | |
| syn-ru | synthetic rubber | | |
| T | teeth | | |
| taper-pt | taper point | | |
| thd | thread(ed) (s) | | |
| thk | thick(ness) | | |
| TM | Technical Manual | | |
| tnd | tinned | | |

16. MANUFACTURERS' SYMBOLS. The following symbols, preceding the manufacturers' part numbers, appear in this supply manual.

| <i>Symbol</i> | <i>Manufacturer</i> |
|---------------|--|
| ABF | Auburn Clutch Co, Div (Dana Corp) |
| AC | AC Spark Plug Div (General Motors Corp) |
| ACK | Armstrong Cork Co |
| AD | Alemite Div (Stewart-Warner Corp) |
| AL | Electric Auto-Lite Co, The |
| ANB | Anderson Brass Co |
| APB | Appliance Mfg Co |
| BA | Bassick Co, The |
| B&B | Beck & Beck Div (Borg-Warner Corp) |
| BOW | Bower Roller Bearing Co |
| BT | Bingham Stamping Div (The Bingham-Herbrand Corp) |
| BX | Bendix Products Div (Bendix Aviation Corp) |
| CA | Columbus Auto Parts Co |
| CAR | Carter Carburetor Corp |
| CC | Chrysler Corp |
| CCS | Chicago Screw Co, The |
| CM | Chicago Rawhide Mfg Co, The |
| CP | Champion Spark Plug Co |
| CPH | Crane Packing Co |
| CU | Cuno Engineering Corp |
| DAY | Day Rubber Co, The |
| DGM | Detroit Gasket & Mfg Co |
| DM | Douglas Mfg Div (Kingston Products Corp) |
| DR | Delco-Remy Div (General Motors Corp) |
| EAT | Eaton Mfg Co |
| EB | Eberhard Mfg Co, Div (Eastern Malleable Iron Co) |
| FDP | Firestone Industrial Products Co |
| FM | Ford Motor Co |
| FR | Fram Corp |
| FS | Fasco Industries, Inc |
| GE | General Electric Co |
| GL | Guide Lamp Div (General Motors Corp) |
| GM | General Motors Corp |
| GPC | Garlock Packing Co, The |
| HAC | Hall, C M, Lamp Co |
| HLH | Holland Hitch Co |
| HY | Hyatt Bearing Div (General Motors Corp) |
| IHC | International Harvester Co, Inc |
| IL | Industrial Lamp Corp |

| <i>Symbol</i> | <i>Manufacturer</i> |
|---------------|--|
| IND | Consolidated Productions |
| KHW | Kelsey-Hayes Wheel Co |
| MAE | Monroe Auto Equipment Co |
| MAR | Maremont Automotive Products, Inc |
| MAT | Mather Spring Co |
| MDR | McCord Corp |
| MID | Midland Steel Products Co, The |
| MNC | McQuay-Norris Mfg Co |
| MRC | Marlin-Rockwell Corp |
| MSP | Midland Steel Products |
| MW | Motor Wheel Corp |
| N&J | North & Judd Mfg Co |
| NMP | National Machine Products Co |
| OKS | Houdaille-Hershey Corp |
| ONB | Ohio Nut and Bolt Co, The |
| PC | Packard Electric Div (General Motors Corp) |
| PEE | Presstite Engineering Co |
| PG | Pierce Governor Co, Inc, The |
| PK | Parker-Kalon Corp |
| PR | Perfect Circle Co, The |
| RBR | Benjamin Reel Products, Inc |
| RG | Ross Gear & Tool Co |
| RWM | Ramsey Winch Mfg Co |
| RZ | Gear Grinding Machine Co, The |
| SCI | Scintilla Magneto Div (Bendix Aviation Corp) |
| SDH | Standard-Thompson Corp |
| SEPC | Sealed Power Corp |
| SHA | Shakespeare Products Co |
| SL | Sheller Mfg Corp |
| SMA | Smith, A O, Corp |

| <i>Symbol</i> | <i>Manufacturer</i> |
|---------------|--|
| SN | Snap-On Tools Corp |
| SP | Spicer Mfg Div (Dana Corp) |
| STN | Stant Mfg Co |
| SW | Stewart-Warner Corp |
| SZ | Schwitzer-Cummins Co |
| TD | Timken Detroit Axle Co |
| TI | Titeflex, Inc |
| TIM | Timken Roller Bearing Co, The |
| TLS | Trostel, Albert & Sons Co |
| TNP | Tinnerman Products, Inc |
| TP | Thompson Products, Inc |
| TRI | Trico Products Corp |
| TRU | American Chain & Cable Co, The |
| UC | United Carr Fastener Corp |
| UCI | Ucinite Co, The |
| UTS | United Air Cleaner Div (United Specialties Co) |
| VG | Victor Mfg & Gasket Co |
| WB | Willard Storage Battery Co |
| WG | Warner Gear Div (Borg-Warner Corp) |
| WH | Weatherhead Co, The |
| WIL | Eaton Mfg Co (Saginaw Div & Valve Div) |
| WO | Willys-Overland Motors, Inc |
| ZP | Skinner Purifier Div (Bendix Aviation Corp) |

17. SUGGESTIONS AND RECOMMENDATIONS. Notice of discrepancies and recommendations should be forwarded through Command Channels to the Chief of Ordnance, Department of the Army, Washington 25, D. C., ATTENTION: ORDFM-Pub.

NOTES

Explanation of Symbols

H-1 SNL symbols such as H-1, etc., refer to the SNL in which the item is reviewed.

‡ As required.

NPN Suffixed to manufacturer symbol indicates that no part number has been assigned or is available. These items are not available as components due to manufacturing processes involved but are available as an assembly, or they may be available as components but not as an assembly. For these reasons the manufacturer has not assigned a part number.

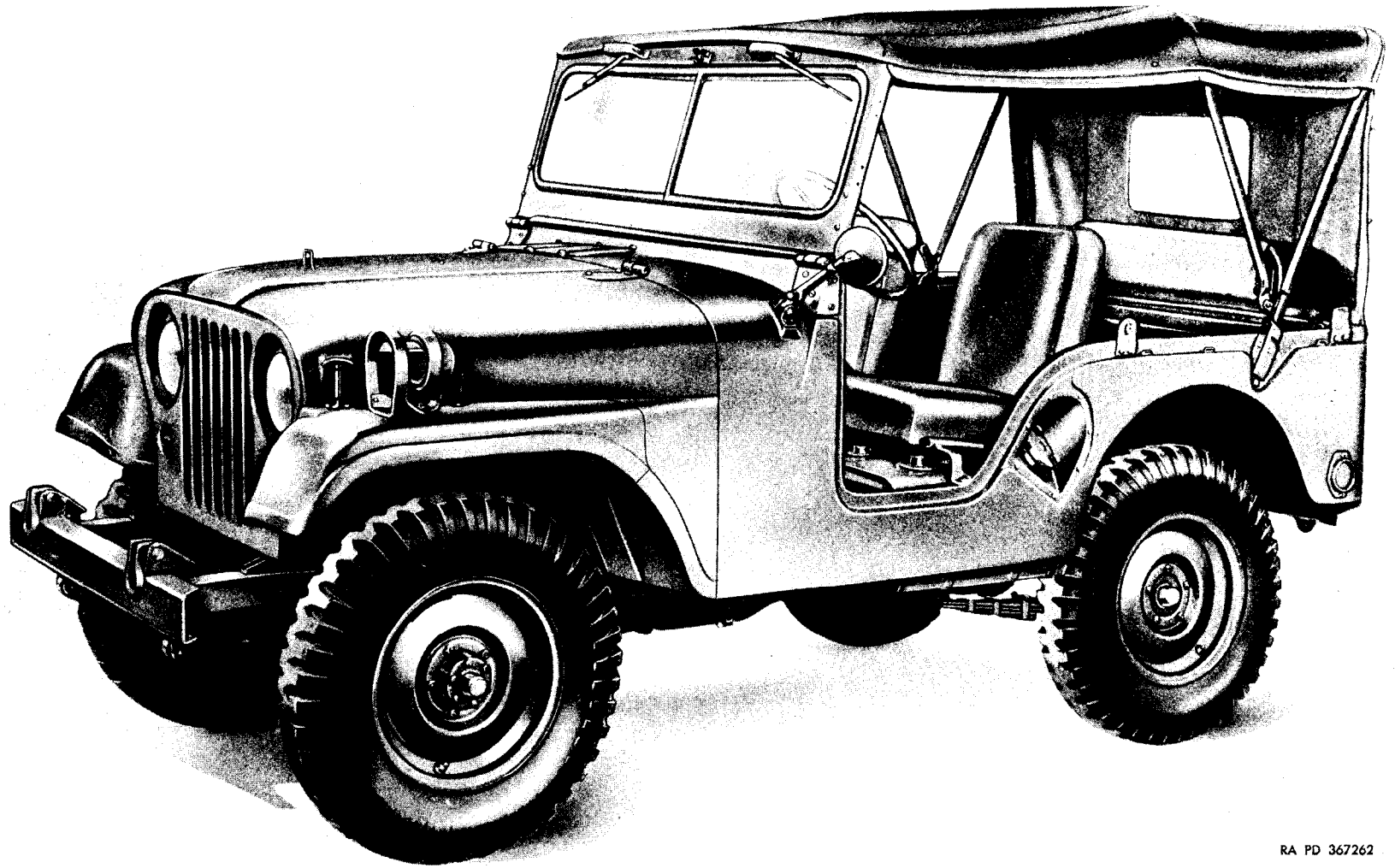

RA PD 367262

Figure 1. Truck, Utility: 1/4-ton, 4 x 4, M38A1—left front view, top up

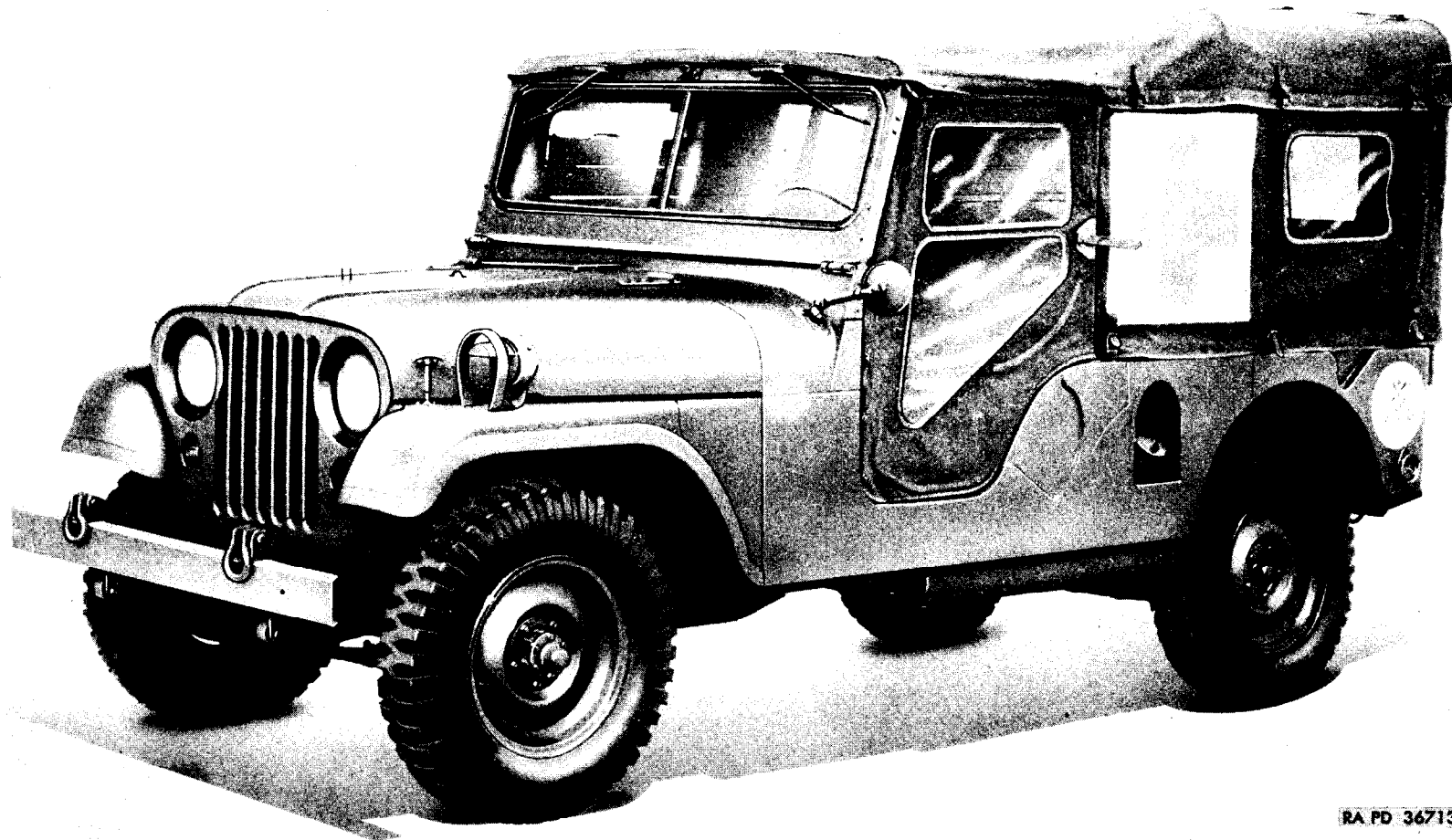

RA PD 36713T

Figure 2. Truck, Ambulance: front line, 1/4-ton, 4 x 4, M170—left front view, top up

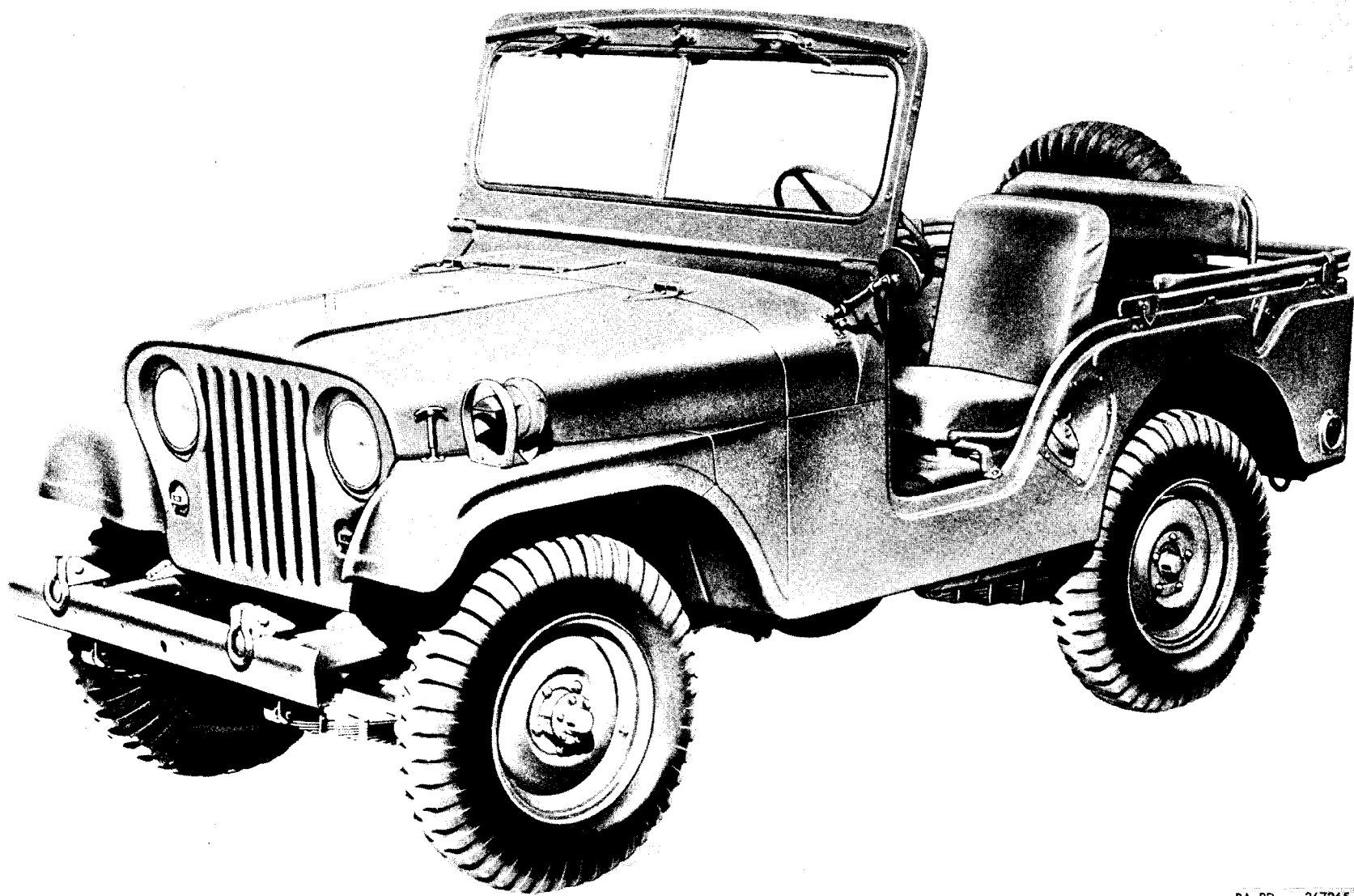
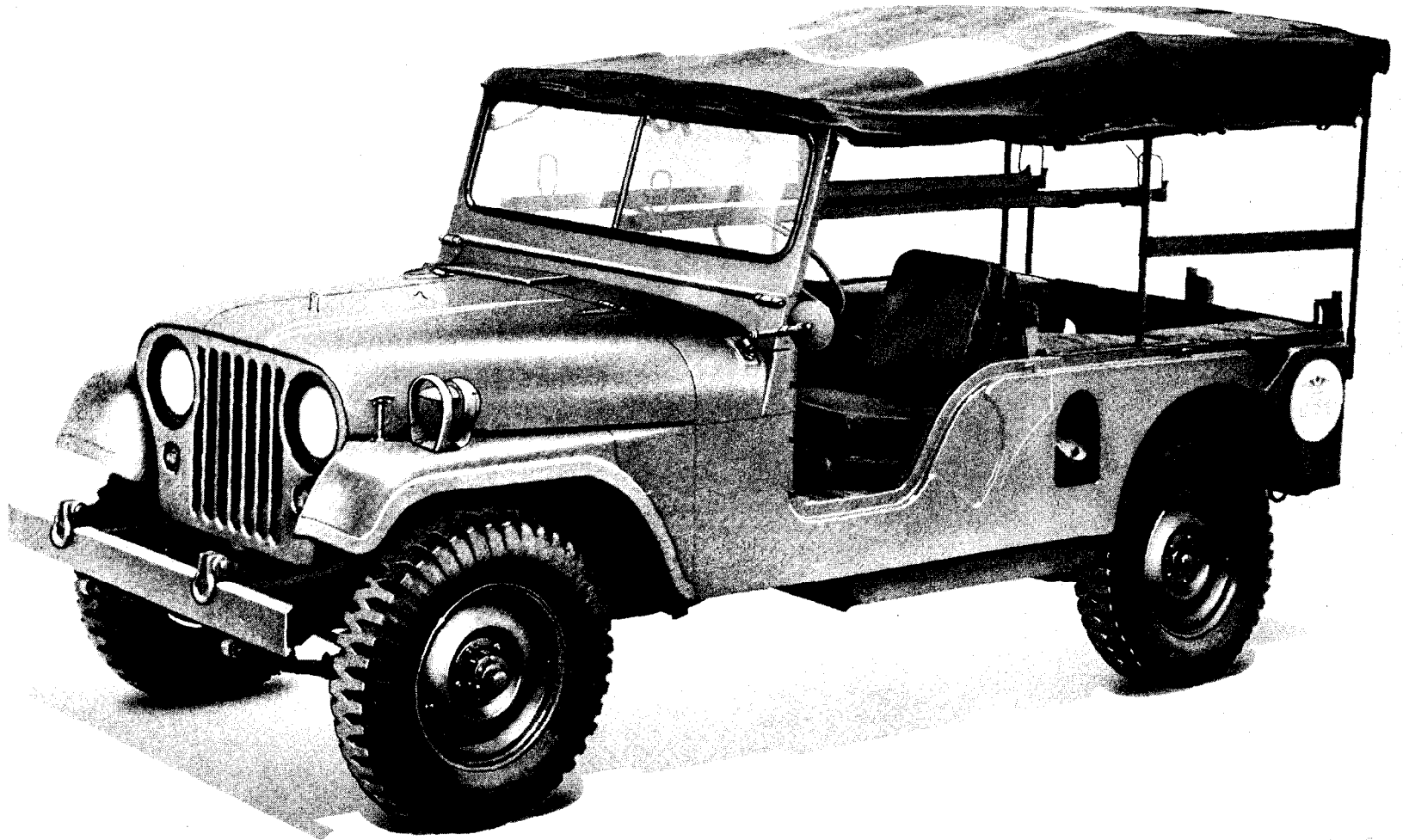
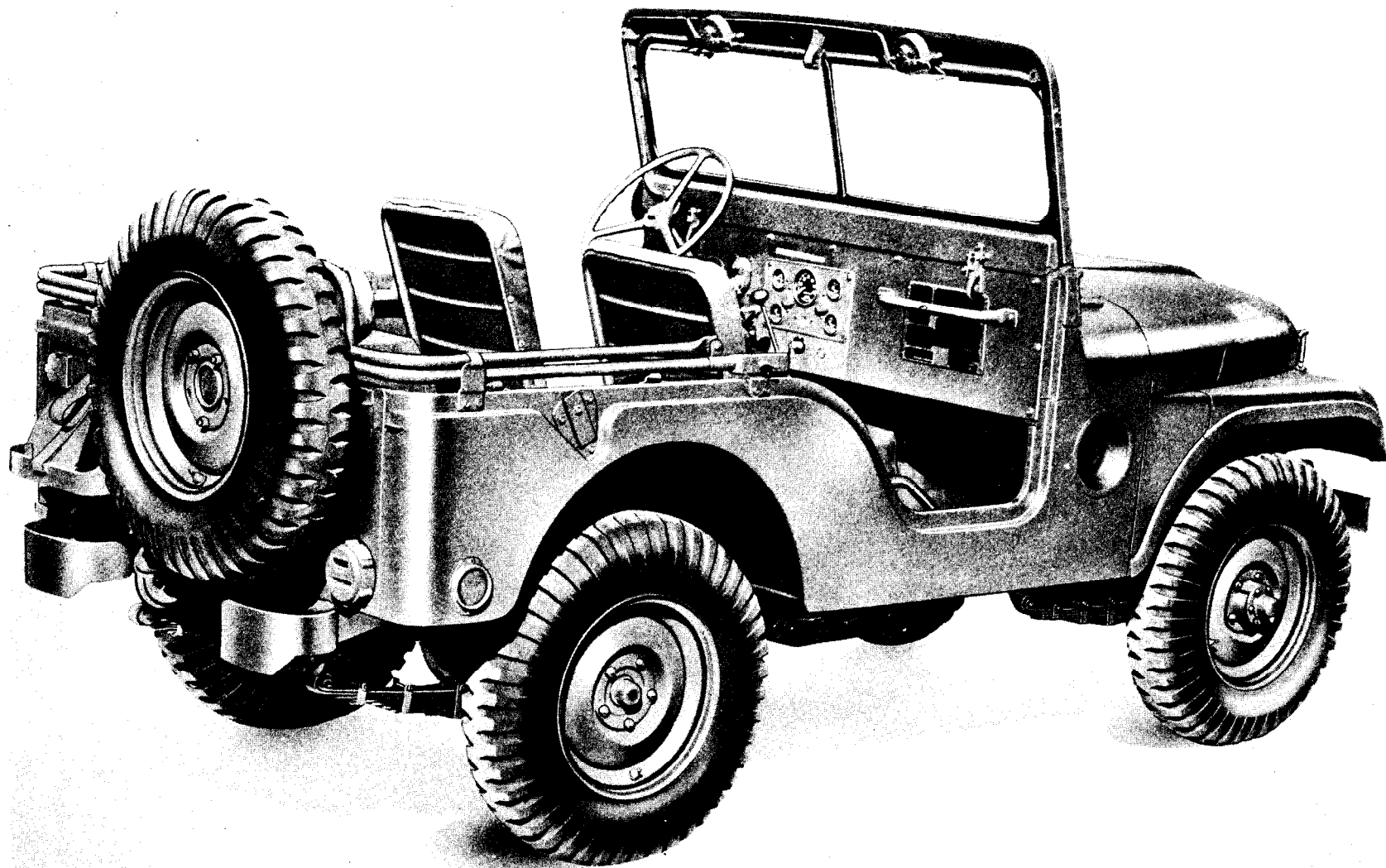

Figure 3. Truck, Utility: 1/4-ton, 4 x 4, M38A1—left front view, top down



RA PD 367132

Figure 4. Truck, Ambulance: front line, 1/4-ton, 4 x 4, M170—left front view, top up



RA PD 367261

Figure 5. Truck, Utility: 1/4-ton, 4 x 4, M38A1—right rear view

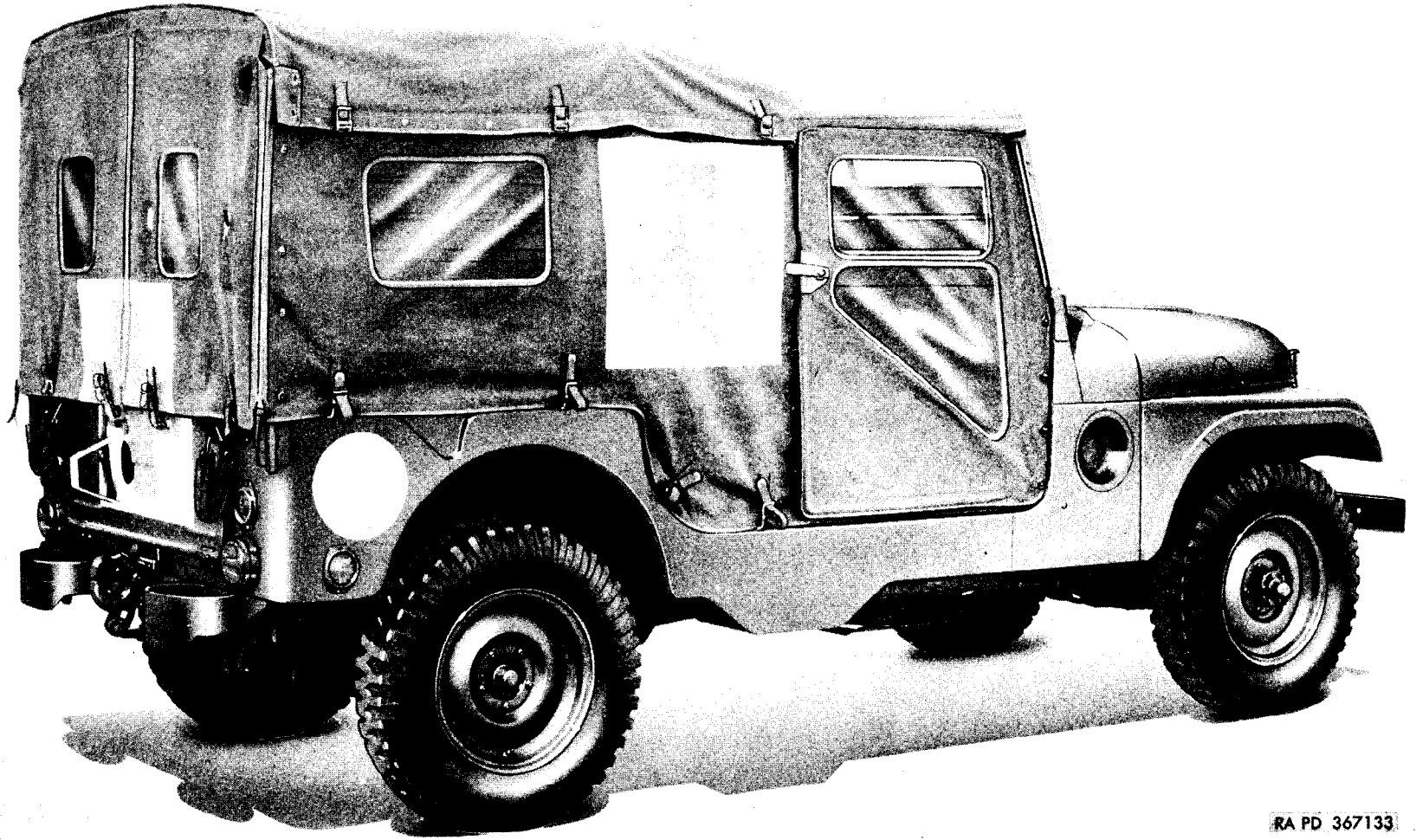

RA PD 367133

Figure 6. Truck, Ambulance: front line, 1/4-ton, 4 x 4, M170—right rear view, top up

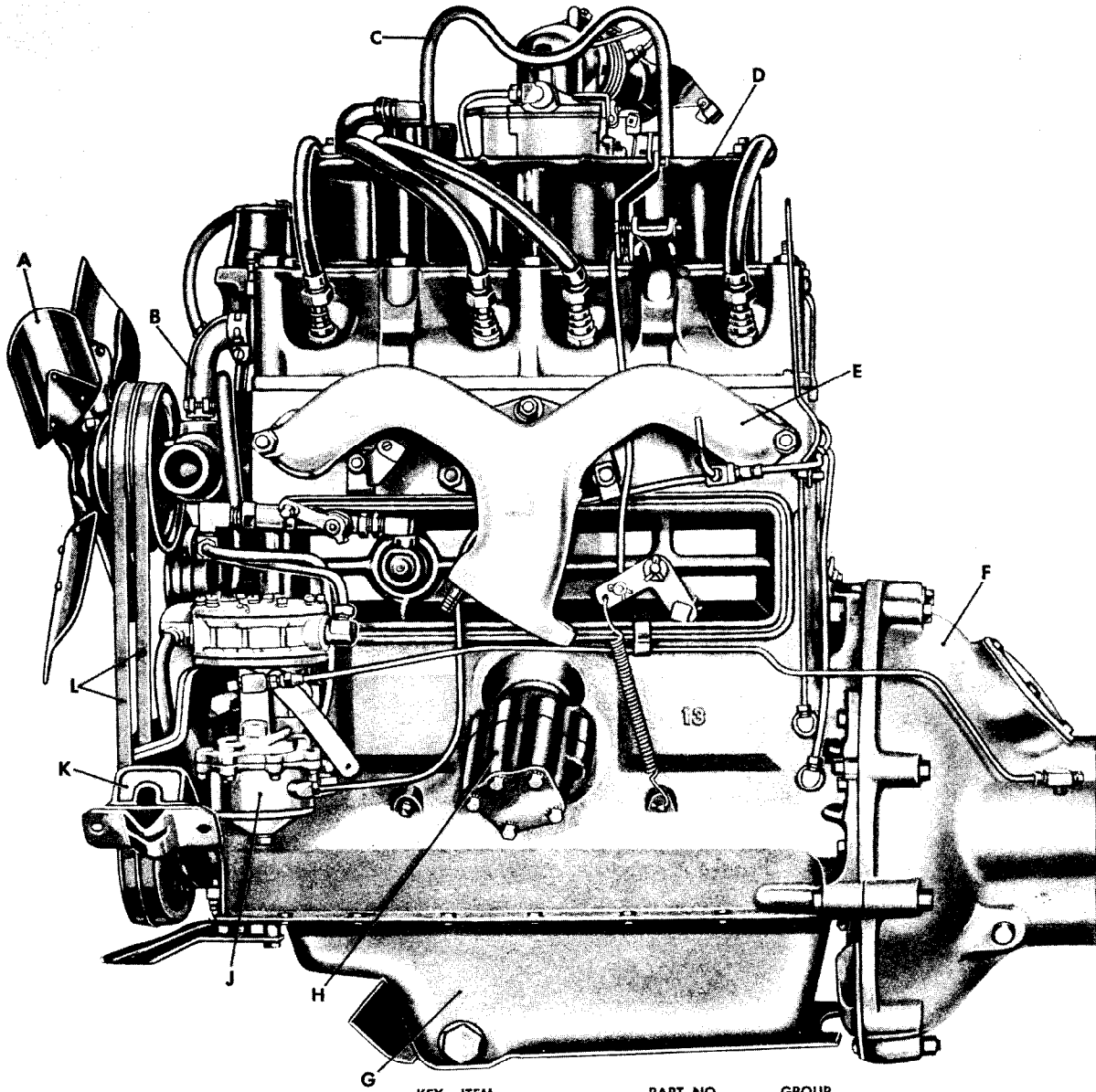

| KEY ITEM | PART NO. | GROUP |
|-----------------------------------|----------|--------|
| A—BLADE, ASSY | 7375021 | 0505 |
| B—HOSE | 7697588 | 0503 |
| C—HOOK | 8332071 | 0100.1 |
| D—COVER, ASSY | 8329713 | 0105.2 |
| E—MANIFOLD, ASSY | 8329699 | 0108 |
| F—HOUSING, ASSY | 8328312 | 0103 |
| G—PAN, ASSY | 7371278 | 0106.6 |
| H—PUMP, ASSY | 7376907 | 0106.1 |
| J—PUMP, ASSY | 8720570 | 0302.1 |
| K—CUSHION | 8328391 | 0100.2 |
| L—BELT | 7697614 | 0505 |
| ITEM "K" NOT PART OF ASSY 8328393 | | |

RA PD 367170

Figure 01-1. Engine assy (8328393)—left side view

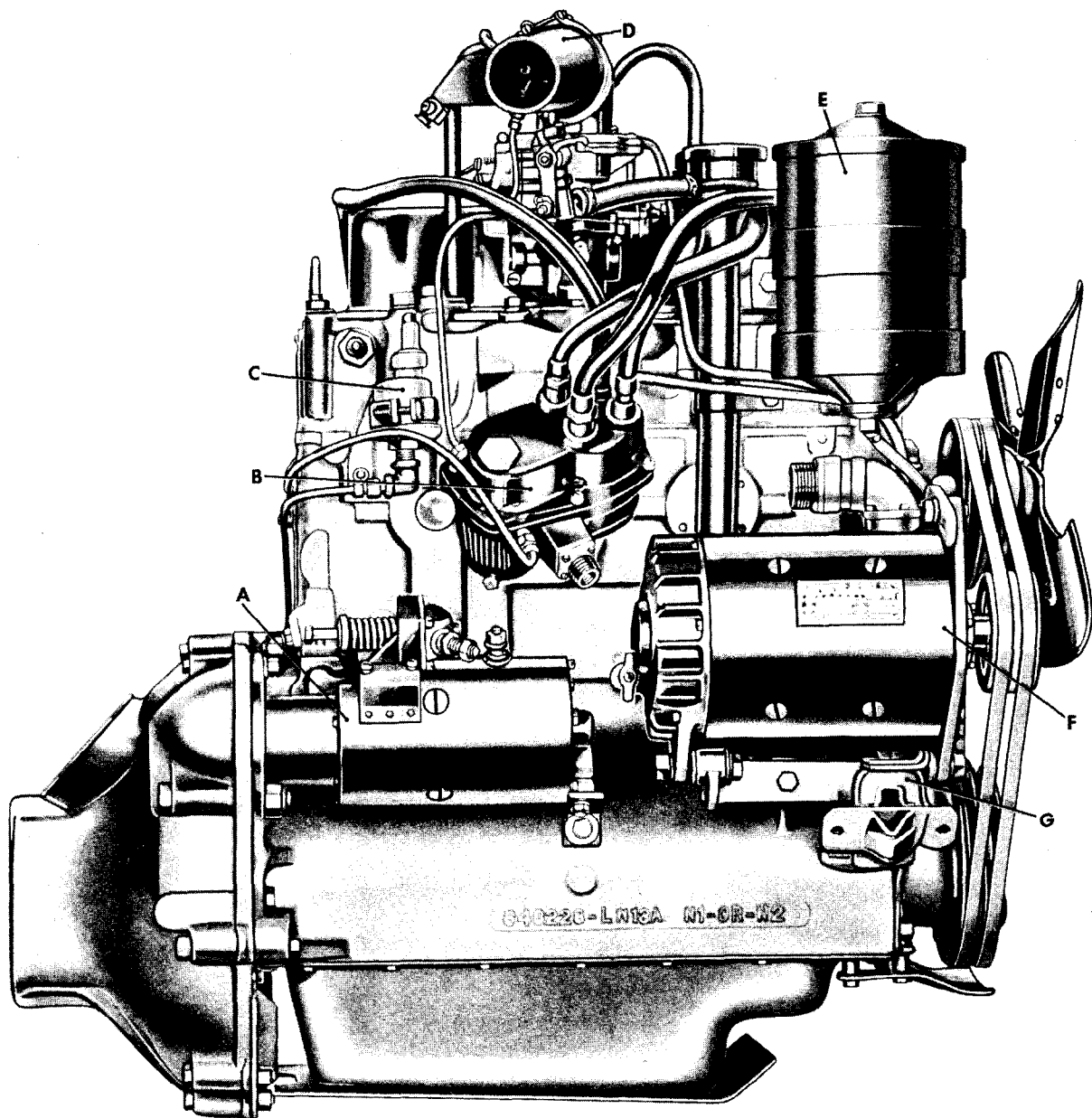

| KEY | ITEM | PART NO. | GROUP |
|-----|-------------------|----------|--------|
| A | STARTER, ASSY | 8328132 | 0603 |
| B | DISTRIBUTOR, ASSY | 7358569 | 0604.1 |
| C | UNIT, ASSY | 7728856 | 0610 |
| D | PIPE, ASSY | 8332084 | 0304.5 |
| E | FILTER, ASSY | 540501 | 0106.2 |
| F | GENERATOR, ASSY | 8673350 | 0601.1 |
| G | CUSHION | 8328391 | 0100.2 |

ITEM "G" IS NOT PART OF ASSY 8328393

RA PD 367176

Figure 01-2. Engine assy (8328393)—right side view

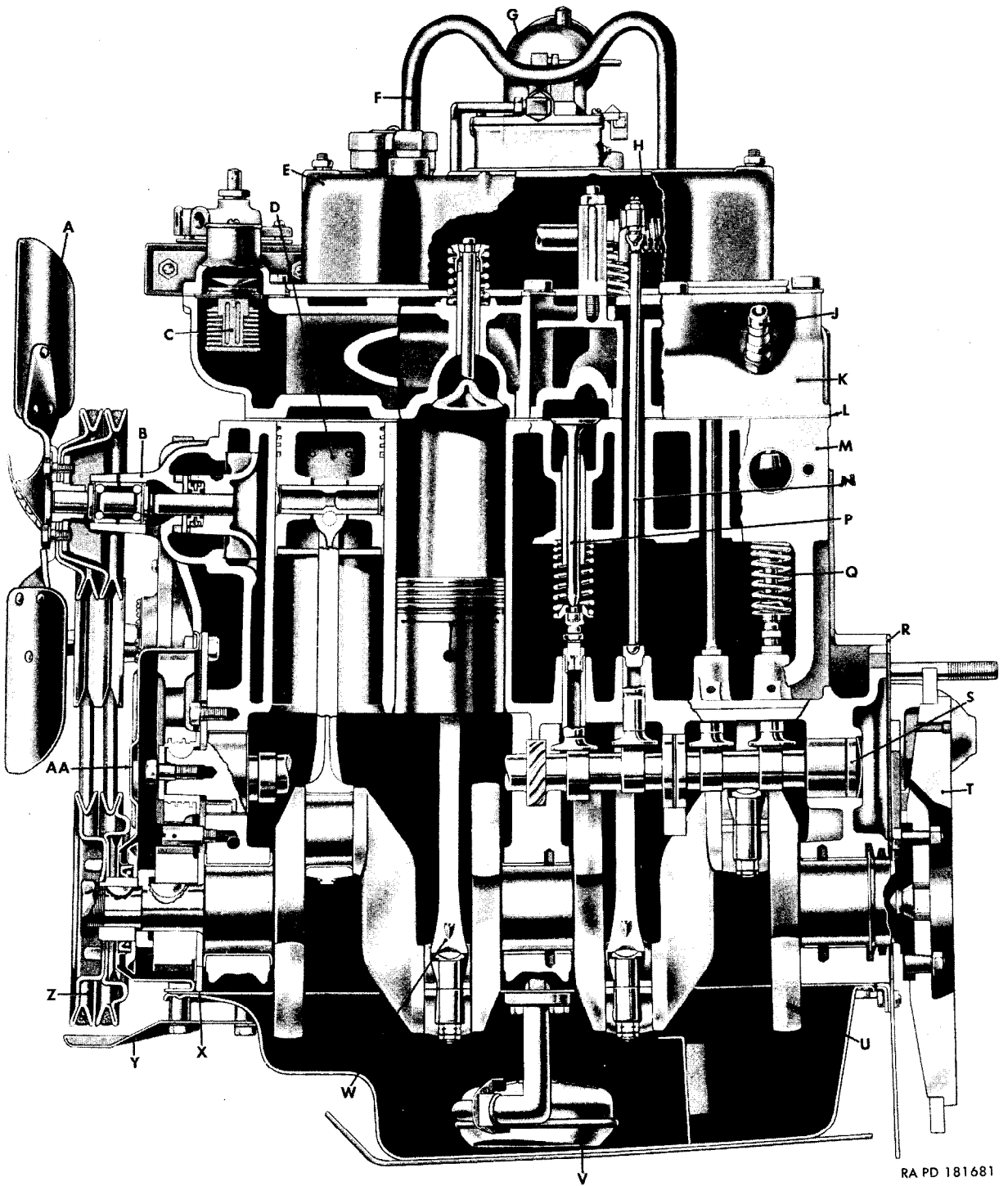

RA PD 181681

Figure 01-3. Engine assy—longitudinal section

| <i>Key</i> | <i>Item</i> | <i>Part No.</i> | <i>Group</i> |
|------------|----------------------|-----------------|--------------|
| A | —BLADE..... | 7375021 | 0505 |
| B | —PUMP, ASSY..... | 7372806 | 0504 |
| C | —THERMOSTAT..... | WO-812050 | 0503 |
| D | —PISTON..... | 7372873 | 0104.1 |
| E | —COVER..... | 8329713 | 0105.2 |
| F | —HOOK..... | 8332071 | 0100.1 |
| G | —PIPE..... | 8332084 | 0304.5 |
| H | —SPRING..... | 8329721 | 0105.2 |
| J | —PLUG..... | 8357724 | 0605 |
| K | —HEAD, ASSY..... | 8328474 | 0101 |
| L | —GASKET..... | 8328463 | 0101 |
| M | —BLOCK, ASSY..... | 8677621 | 0101 |
| N | —ROD..... | 8330073 | 0105.2 |
| P | —VALVE..... | 8329517 | 0105.1 |
| Q | —SPRING..... | 7371235 | 0105.1 |
| R | —PLATE..... | 8328047 | 0103 |
| S | —CAMSHAFT..... | 8329698 | 0105.3 |
| T | —FLYWHEEL, ASSY..... | WO-804314 | 0103 |
| U | —CRANKSHAFT..... | 8673476 | 0102.1 |
| V | —STRAINER, ASSY..... | 7036578 | 0106.6 |
| W | —ROD, ASSY..... | 7743751 | 0104.2 |
| X | —PLATE..... | 7372578 | 0105.5 |
| Y | —SHIELD..... | 7371376 | 0102.1 |
| Z | —PULLEY..... | 7372558 | 0102.1 |
| AA | —COVER..... | 7372576 | 0105.5 |

Figure 01-3. Engine assy—longitudinal section—legend

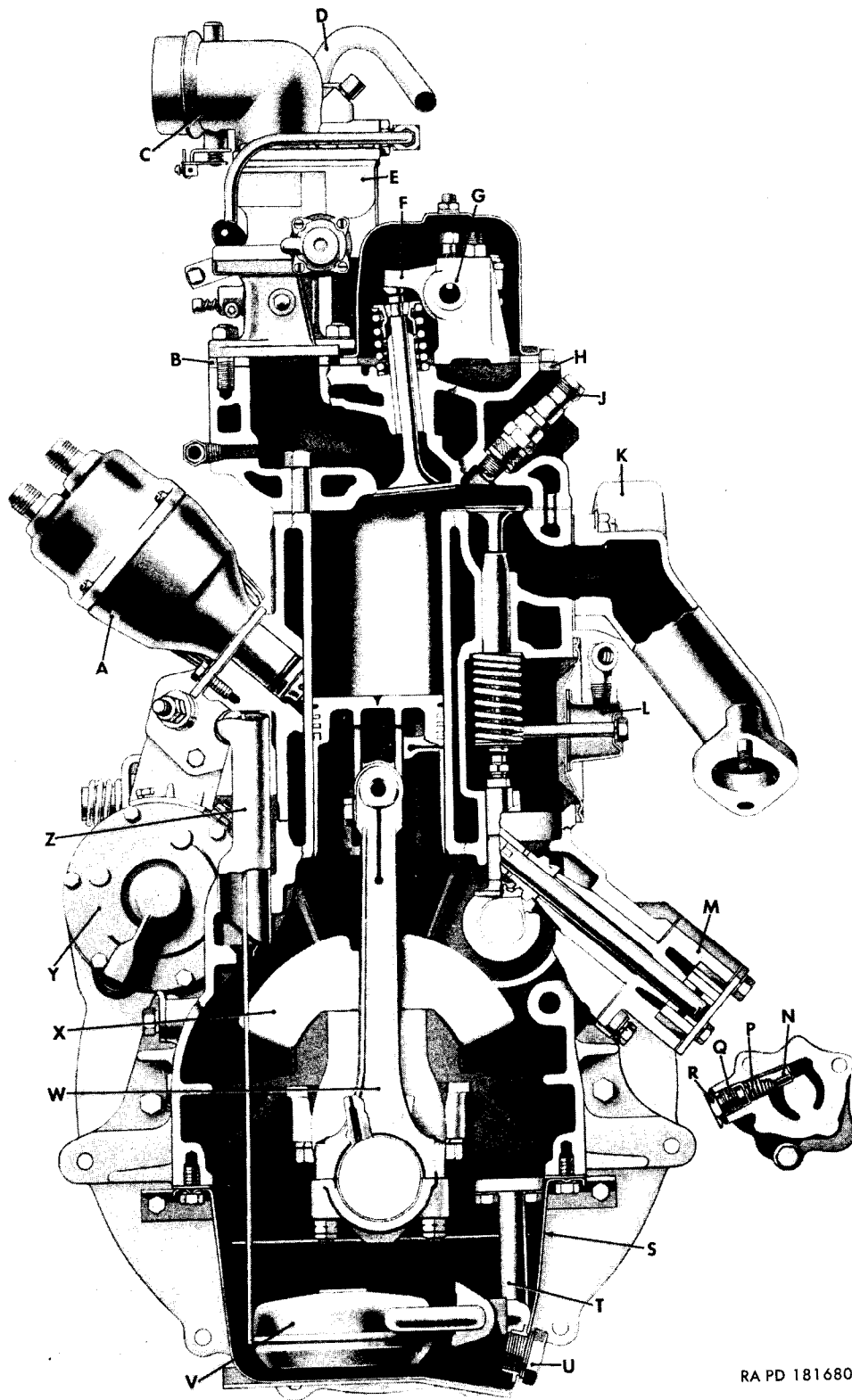

RA PD 181680

Figure 01-4. Engine assy—end sectional view

| <i>Key</i> | <i>Item</i> | <i>Part No.</i> | <i>Group</i> |
|------------|-------------------------|-----------------|--------------|
| A | -DISTRIBUTOR, ASSY..... | 7358569 | 0604.1 |
| B | -GASKET..... | 8328463 | 0101 |
| C | -PIPE..... | 8332084 | 0304.5 |
| D | -HOOK..... | 8332071 | 0100.1 |
| E | -CARBURETOR, ASSY..... | 8329774 | 0301 |
| F | -ARM, ASSY..... | 8329710 | 0105.2 |
| G | -SHAFT, ASSY..... | 8329720 | 0105.2 |
| H | -HEAD, ASSY..... | 8328474 | 0101 |
| J | -PLUG..... | 8357724 | 0605 |
| K | -MANIFOLD, ASSY..... | 8329699 | 0108 |
| L | -VENTILATOR, ASSY..... | 7371286 | 0106.5 |
| M | -PUMP, ASSY..... | 7376907 | 0106.1 |
| N | -VALVE..... | 7371275 | 0106.1 |
| P | -SPRING..... | 8331246 | 0106.1 |
| Q | -SHIM..... | 7371263 | 0106.1 |
| R | -RETAINER..... | 7371271 | 0106.1 |
| S | -PAN, ASSY..... | 7371278 | 0106.6 |
| T | -SUPPORT..... | 7371264 | 0106.6 |
| U | -PLUG..... | 7351892 | 0106.6 |
| V | -STRAINER, ASSY..... | 7036578 | 0106.6 |
| W | -ROD, ASSY..... | 7743751 | 0104.2 |
| X | -CRANKSHAFT..... | 8673476 | 0102.1 |
| Y | -STARTER, ASSY..... | 8328132 | 0603 |
| Z | -PIPE, ASSY..... | 8329683 | 0106.5 |

Figure 01-4. Engine assy—end sectional view—legend

| KEY ITEM | PART NO. | GROUP |
|-------------|----------|--------|
| A-PLUG | 103877 | 0101 |
| B-HEAD | 8677437 | 0101 |
| C-NIPPLE | 7372808 | 0503 |
| D-STUD | 8329679 | 0101 |
| E-PLUG | 143933 | 0101 |
| F-STUD | 178453 | 0301 |
| G-CONNECTOR | 137404 | 0106.6 |
| H-PLUG | 103868 | 0101 |
| J-GUIDE | 8329691 | 0105.1 |

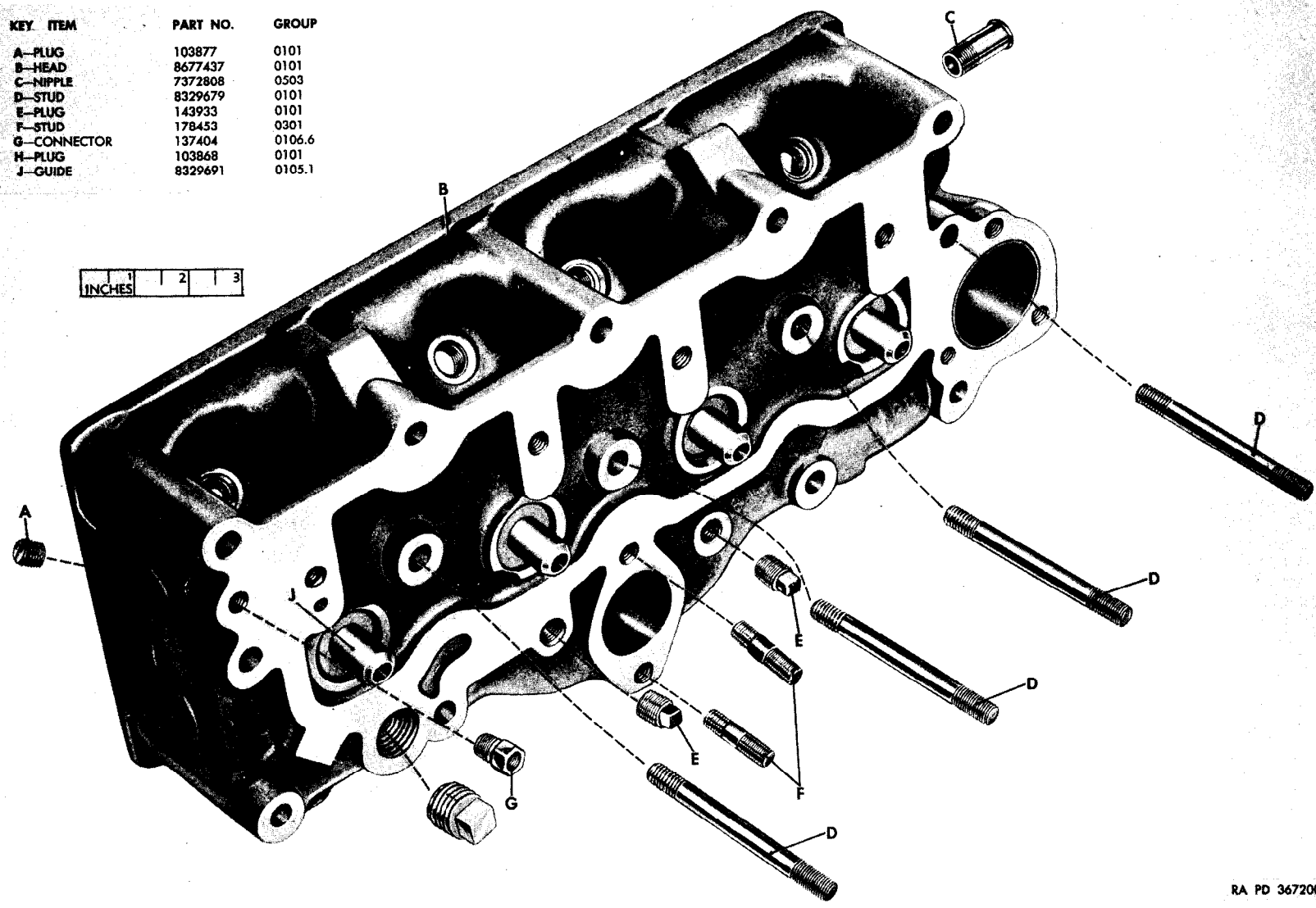
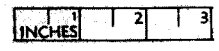

20

RA PD 367200

Figure 01-5. Cylinder head, assy (8328474)—exploded view

| KEY | ITEM | PART NO. | GROUP |
|-----|---------------|----------|--------|
| A | SLINGER | 7371161 | 0102.1 |
| B | SPACER | 7741414 | 0105.5 |
| C | GEAR | 7741415 | 0105.5 |
| D | KEY | 124552 | 0105.5 |
| E | WASHER | 7371160 | 0102.1 |
| F | SHIM | 7371226 | 0102.1 |
| G | BEARING, ASSY | 7372564 | 0102.2 |
| H | PIN | 7371229 | 0102.2 |
| J | BEARING, ASSY | 7372565 | 0102.2 |
| K | BEARING, ASSY | 7372566 | 0102.2 |
| L | BOLT | 7324840 | 0103 |
| M | CRANKSHAFT | 8673476 | 0102.1 |
| N | PIN | 7371231 | 0103 |

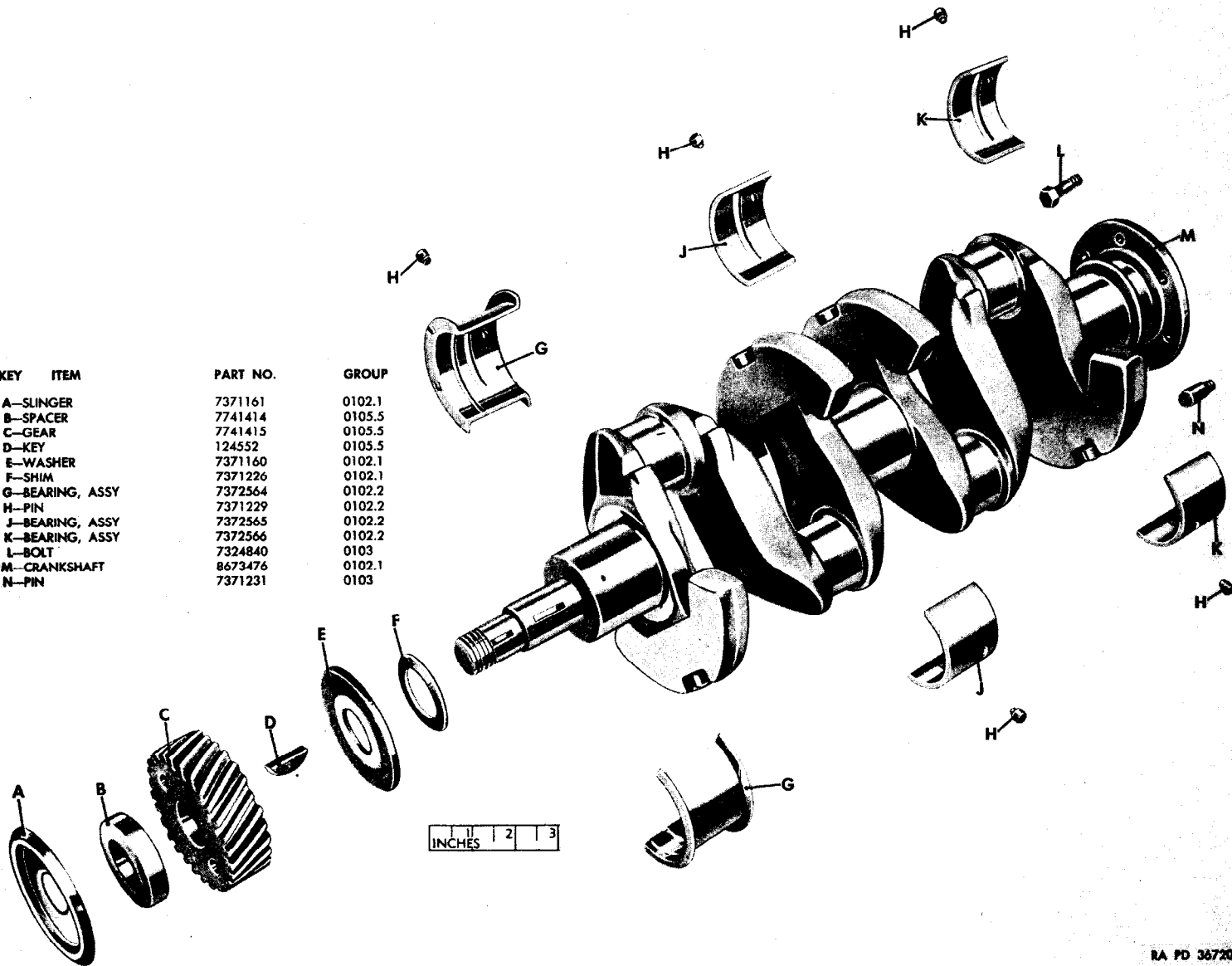

RA PD 367201

Figure 01-6. Crankshaft and bearings—exploded view

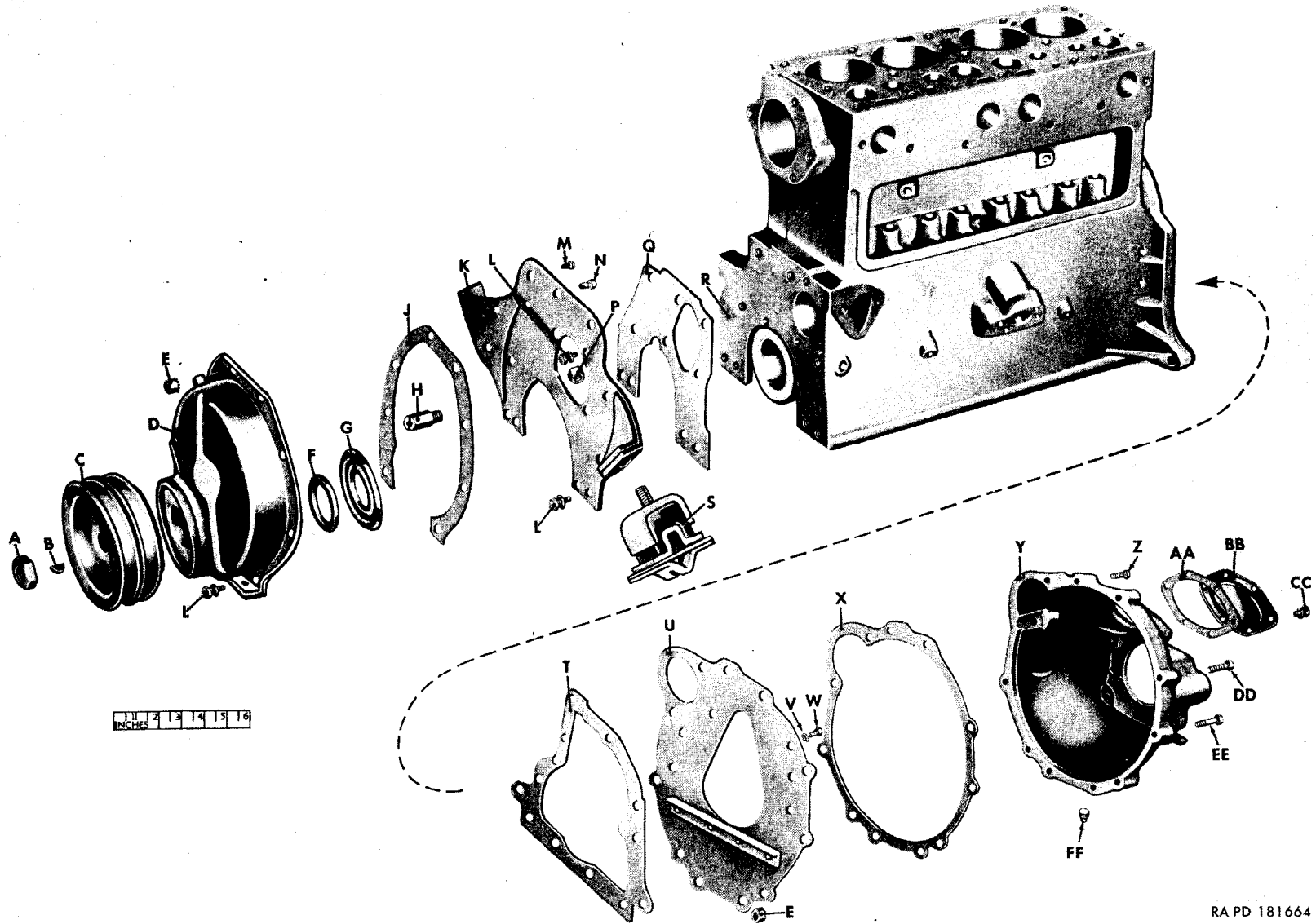

RA PD 181664

Figure 01-7. Cylinder block, flywheel housing and gear cover—exploded view

| Key | Item | Part No. | Group |
|-----|---------------------|----------|----------|
| A | -NUT..... | 7697864 | 0102.1 |
| B | -KEY..... | 124549 | 0102.1 |
| C | -PULLEY..... | 7372558 | 0102.1 |
| D | -COVER..... | 7372576 | 0105.5 |
| E | -NUT..... | 271193 | { 0103 |
| | | | { 0105.5 |
| F | -SEAL..... | 7375028 | 0102.1 |
| G | -SLINGER..... | 7371161 | 0102.1 |
| H | -FITTING..... | 7372557 | 0106.6 |
| J | -GASKET..... | 7371159 | 0105.5 |
| K | -PLATE..... | 7372578 | 0105.5 |
| L | -BOLT..... | 423569 | 0105.5 |
| M | -SCREW..... | 123520 | 0105.5 |
| N | -SCREW..... | 120647 | 0105.5 |
| P | -NUT..... | 271187 | 0100.2 |
| Q | -GASKET..... | 7741427 | 0105.5 |
| R | -BLOCK..... | 8677621 | 0101 |
| S | -CUSHION..... | 8328391 | 0100.2 |
| T | -GASKET..... | 8328049 | 0103 |
| U | -PLATE..... | 8328047 | 0103 |
| V | -WASHER..... | A226060 | 0103 |
| W | -SCREW..... | 121661 | 0103 |
| X | -GASKET..... | 8328048 | 0103 |
| Y | -HOUSING, ASSY..... | 8328312 | 0103 |
| Z | -SCREW..... | 124128 | 0103 |
| AA | -GASKET..... | 8328313 | 0103 |
| BB | -COVER..... | 8328310 | 0103 |
| CC | -BOLT..... | 9409106 | 0103 |
| DD | -SCREW..... | 120640 | 0103 |
| EE | -BOLT..... | 8328311 | 0103 |
| FF | -PLUG..... | 103865 | 0103 |

Figure 01-7. Cylinder block, flywheel housing and gear cover—legend

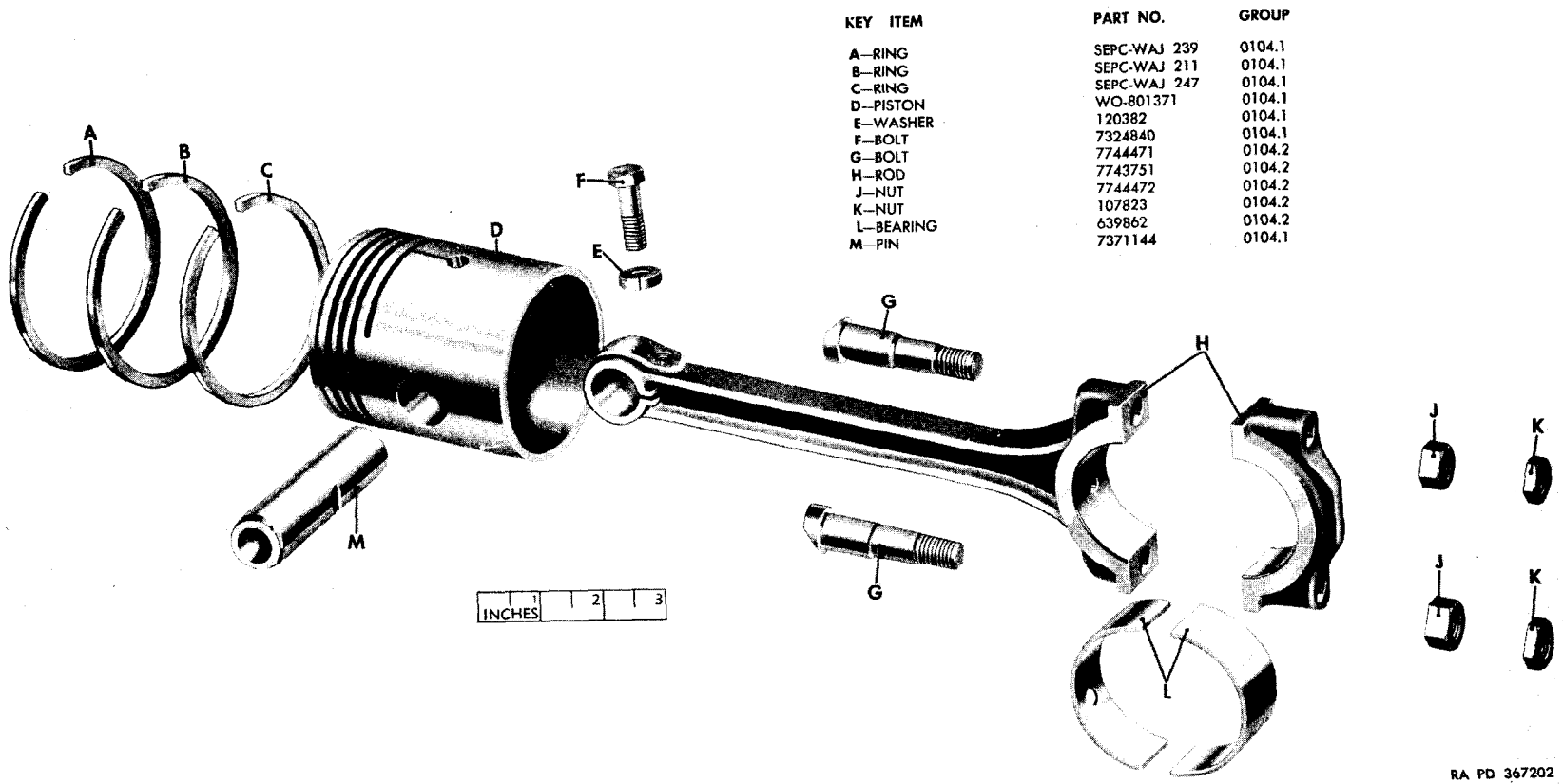

| KEY ITEM | PART NO. | GROUP |
|-----------|--------------|--------|
| A-RING | SEPC-WAJ 239 | 0104.1 |
| B-RING | SEPC-WAJ 211 | 0104.1 |
| C-RING | SEPC-WAJ 247 | 0104.1 |
| D-PISTON | WO-801371 | 0104.1 |
| E-WASHER | 120382 | 0104.1 |
| F-BOLT | 7324840 | 0104.1 |
| G-BOLT | 7744471 | 0104.2 |
| H-ROD | 7743751 | 0104.2 |
| J-NUT | 7744472 | 0104.2 |
| K-NUT | 107823 | 0104.2 |
| L-BEARING | 639862 | 0104.2 |
| M-PIN | 7371144 | 0104.1 |

Figure 01-8. Piston and connecting rod—exploded view

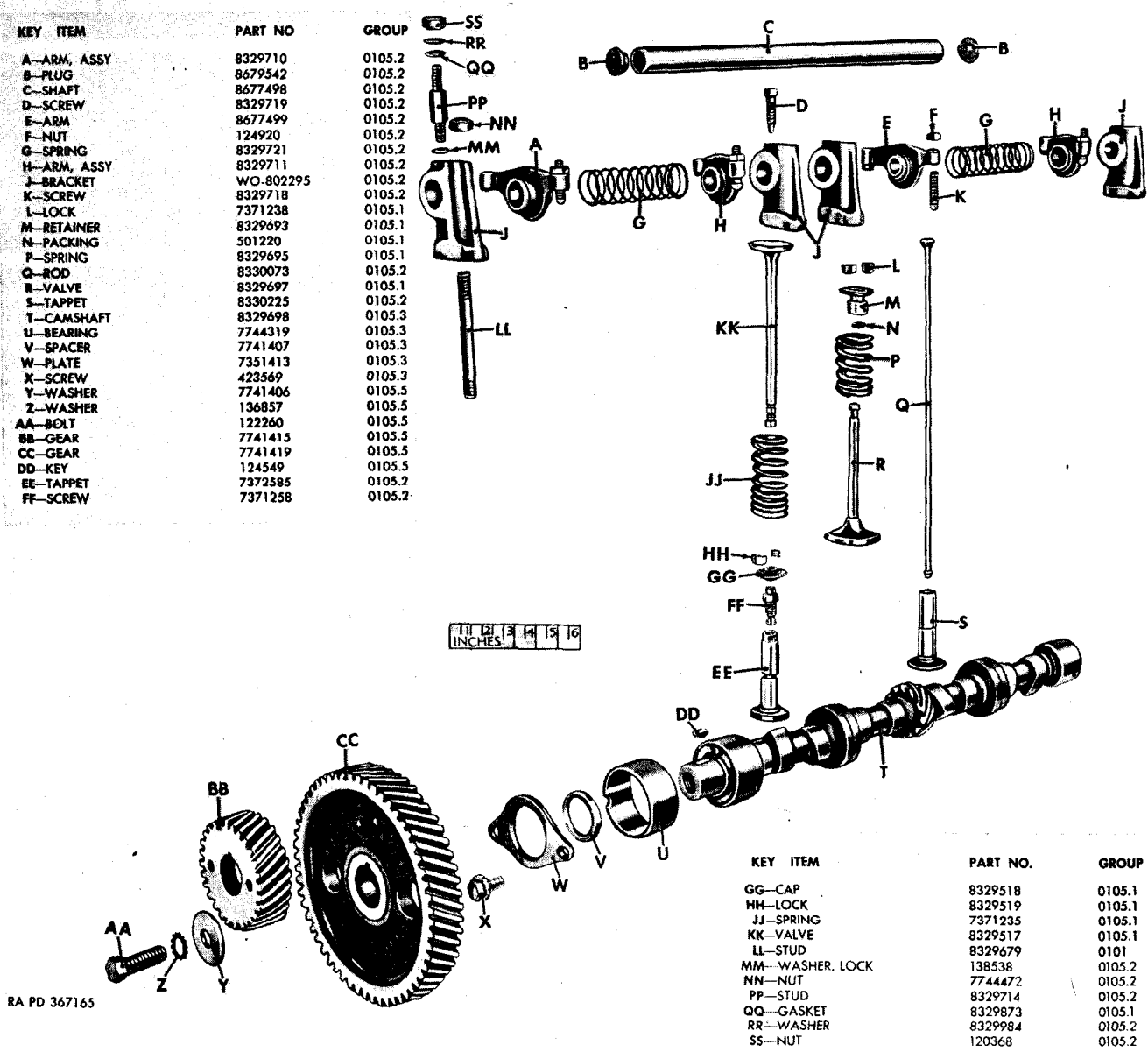

| KEY ITEM | PART NO |
|-------------|-----------|
| A-ARM, ASSY | 8329710 |
| B-PLUG | 8679542 |
| C-SHAFT | 8677498 |
| D-SCREW | 8329719 |
| E-ARM | 8677499 |
| F-NUT | 124920 |
| G-SPRING | 8329721 |
| H-ARM, ASSY | 8329711 |
| J-BRACKET | WO-802295 |
| K-SCREW | 8329718 |
| L-LOCK | 7371238 |
| M-RETAINER | 8329693 |
| N-PACKING | 501220 |
| P-SPRING | 8329695 |
| Q-ROD | 8330073 |
| R-VALVE | 8329697 |
| S-TAPPET | 8330225 |
| T-CAMSHAFT | 8329698 |
| U-BEARING | 7744319 |
| V-SPACER | 7741407 |
| W-PLATE | 7351413 |
| X-SCREW | 423569 |
| Y-WASHER | 7741406 |
| Z-WASHER | 136857 |
| AA-BOLT | 122260 |
| BB-GEAR | 7741415 |
| CC-GEAR | 7741419 |
| DD-KEY | 124549 |
| EE-TAPPET | 7372585 |
| FF-SCREW | 7371258 |

| GROUP | KEY ITEM | PART NO |
|--------|-----------------|---------|
| 0105.2 | SS-NUT | |
| 0105.2 | RR-WASHER | |
| 0105.2 | QQ-GASKET | |
| 0105.2 | PP-STUD | |
| 0105.2 | NN-NUT | |
| 0105.2 | MM-WASHER, LOCK | |
| 0105.2 | AA-BOLT | |
| 0105.2 | LL-STUD | |
| 0105.1 | JJ-SPRING | |
| 0105.1 | KK-VALVE | |
| 0105.1 | LL-LOCK | |
| 0105.1 | MM-RETAINER | |
| 0105.1 | NN-PACKING | |
| 0105.1 | PP-SPRING | |
| 0105.1 | QQ-ROD | |
| 0105.1 | RR-VALVE | |
| 0105.2 | SS-TAPPET | |
| 0105.3 | TT-CAMSHAFT | |
| 0105.3 | UU-BEARING | |
| 0105.3 | VV-SPACER | |
| 0105.3 | WW-PLATE | |
| 0105.3 | XX-SCREW | |
| 0105.5 | YY-WASHER | |
| 0105.5 | ZZ-WASHER | |
| 0105.5 | AAA-BOLT | |
| 0105.5 | BBB-GEAR | |
| 0105.5 | CCC-GEAR | |
| 0105.5 | DDD-KEY | |
| 0105.2 | EEE-TAPPET | |
| 0105.2 | FFF-SCREW | |

| KEY ITEM | PART NO. | GROUP |
|-----------------|----------|--------|
| GG-CAP | 8329518 | 0105.1 |
| HH-LOCK | 8329519 | 0105.1 |
| JJ-SPRING | 7371235 | 0105.1 |
| KK-VALVE | 8329517 | 0105.1 |
| LL-STUD | 8329679 | 0101 |
| MM-WASHER, LOCK | 138538 | 0105.2 |
| NN-NUT | 7744472 | 0105.2 |
| PP-STUD | 8329714 | 0105.2 |
| QQ-GASKET | 8329873 | 0105.1 |
| RR-WASHER | 8329984 | 0105.2 |
| SS-NUT | 120368 | 0105.2 |

RA PD 367165

Figure 01-9. Camshaft, timing gears and valves—exploded view

| KEY ITEM | PART NO. |
|------------|-------------------|
| A-BOLT | 180018 |
| B-COVER | 7744332 |
| C-GASKET | 7744324 |
| D-ROTOR | 8673952 |
| E-ROTOR | EAT-ER4642J |
| F-PIN | EAT-ER90419-11/16 |
| G-SHAFT | EAT-ER6303 |
| H-BODY | EAT-ER3675 |
| J-GEAR | 7744333 |
| K-GASKET | 7372587 |
| L-PIN | 141138 |
| M-RETAINER | 7371271 |
| N-GASKET | 7371270 |
| P-SPRING | 8331246 |
| Q-VALVE | 7371275 |

ALL PARTS LISTED ARE IN GROUP 0106.1

NOTE: ITEM K IS NOT PART OF ASSY 7376907

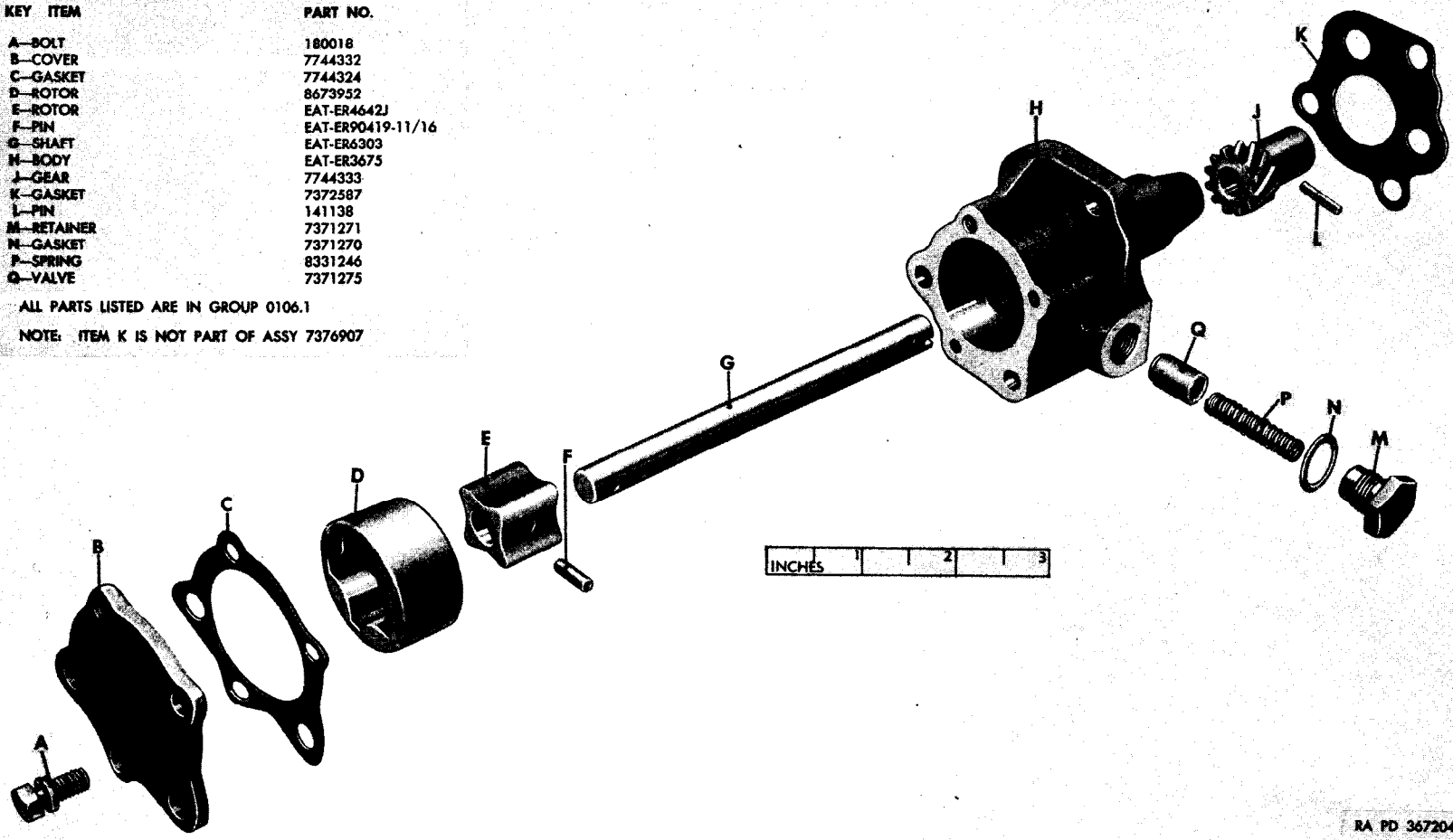
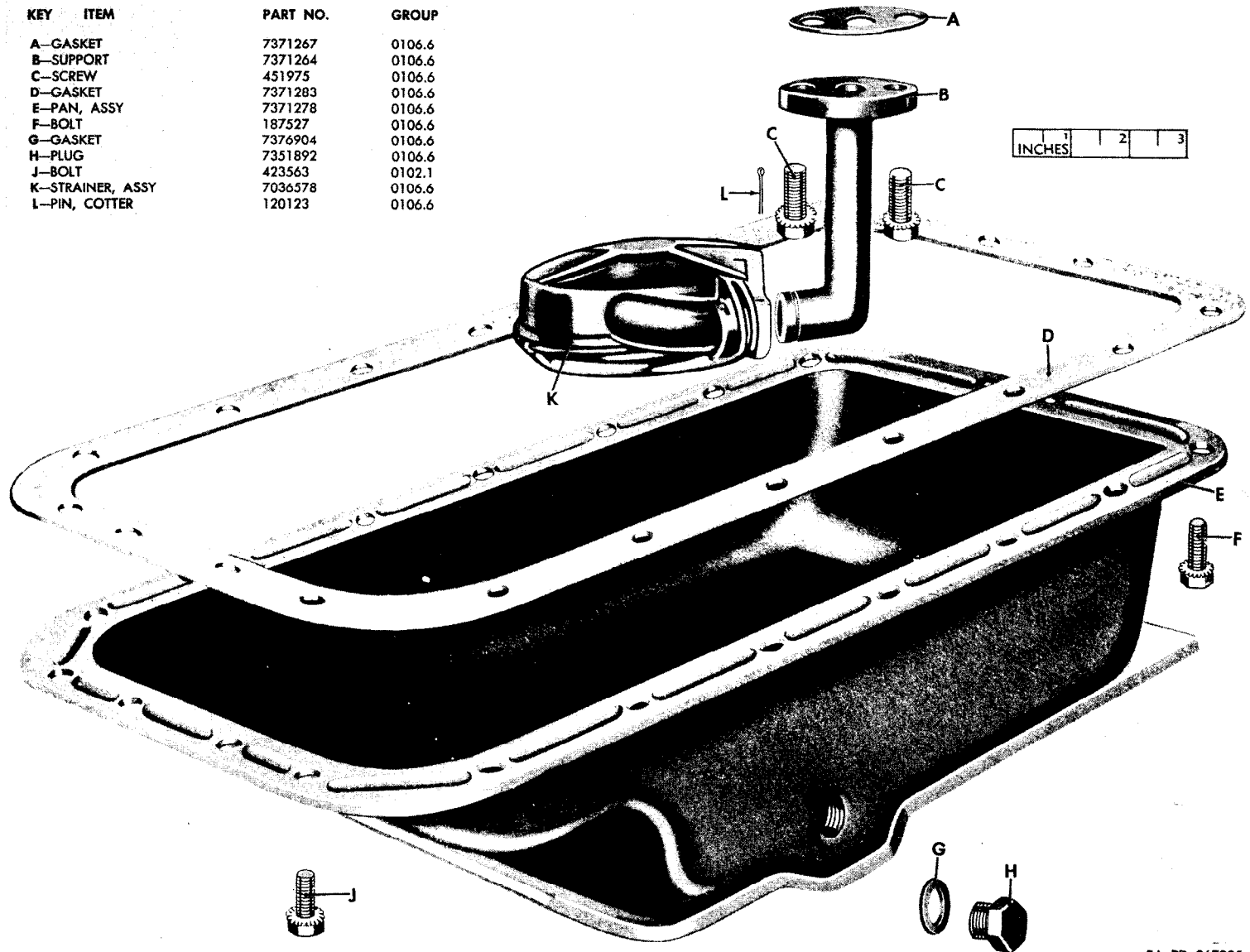

Figure 01-10. Oil pump, assy (7376907)—exploded view

| KEY | ITEM | PART NO. | GROUP |
|-----|----------------|----------|--------|
| A | GASKET | 7371267 | 0106.6 |
| B | SUPPORT | 7371264 | 0106.6 |
| C | SCREW | 451975 | 0106.6 |
| D | GASKET | 7371283 | 0106.6 |
| E | PAN, ASSY | 7371278 | 0106.6 |
| F | BOLT | 187527 | 0106.6 |
| G | GASKET | 7376904 | 0106.6 |
| H | PLUG | 7351892 | 0106.6 |
| J | BOLT | 423563 | 0102.1 |
| K | STRAINER, ASSY | 7036578 | 0106.6 |
| L | PIN, COTTER | 120123 | 0106.6 |



27

RA PD 367225

Figure 01-11. Oil pan—exploded view

KEY ITEM

- A—SCREW
- B—WASHER
- C—CLAMP
- D—BODY
- E—GROMMET
- F—ELEMENT
- G—SPRING
- H—GASKET
- J—COVER
- K—GASKET
- L—SCREW
- M—NUT

- PART NO**
- 133129
- 116120
- FR-102153
- FR-5310-2
- FR-100918
- 540462
- A308282
- 7039934
- 7529093
- 5308281
- 5308280
- 120399

NOTE: ALL PARTS LISTED ARE
IN GROUP 0106.2

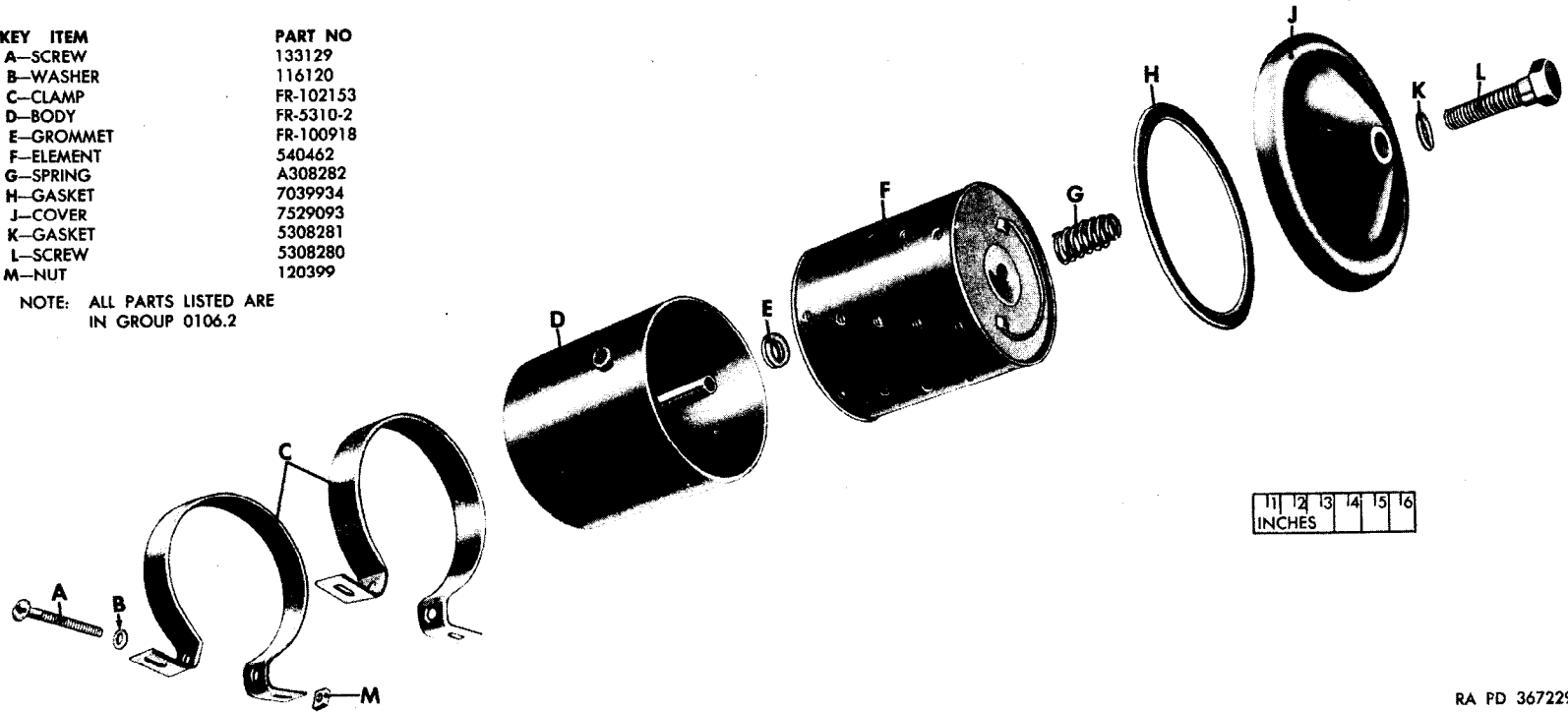

RA PD 367229

Figure 01-12. Oil filter, assy (540501) (Fram)—exploded view

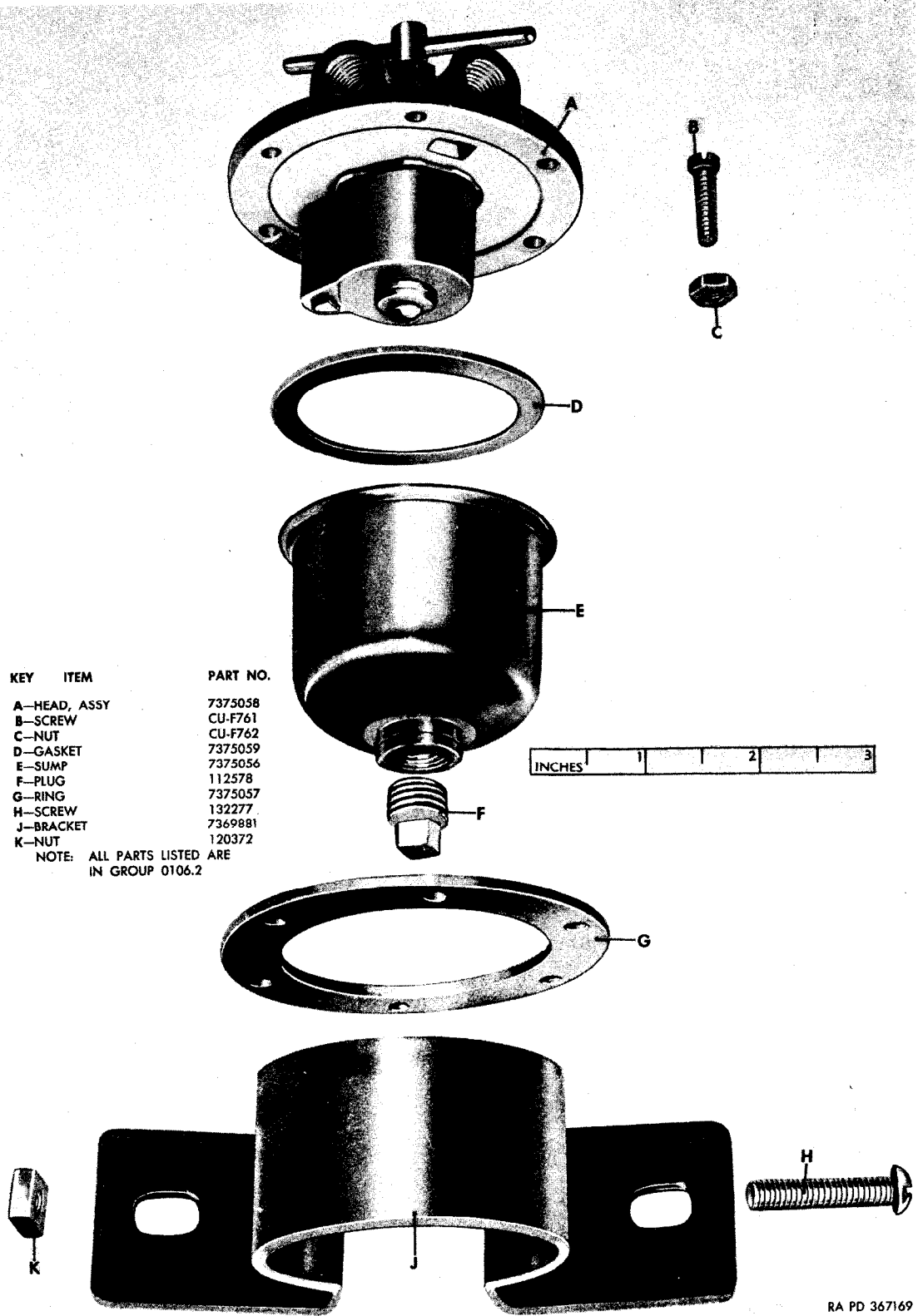

| KEY | ITEM | PART NO. |
|-----|------------|----------|
| A | HEAD, ASSY | 7375058 |
| B | SCREW | CU-F761 |
| C | NUT | CU-F762 |
| D | GASKET | 7375059 |
| E | SUMP | 7375056 |
| F | PLUG | 112578 |
| G | RING | 7375057 |
| H | SCREW | 132277 |
| J | BRACKET | 7369881 |
| K | NUT | 120372 |

NOTE: ALL PARTS LISTED ARE IN GROUP 0106.2



RA PD 367169

Figure 01-13. Oil filter, assy (7375060) (Cuno)—exploded view

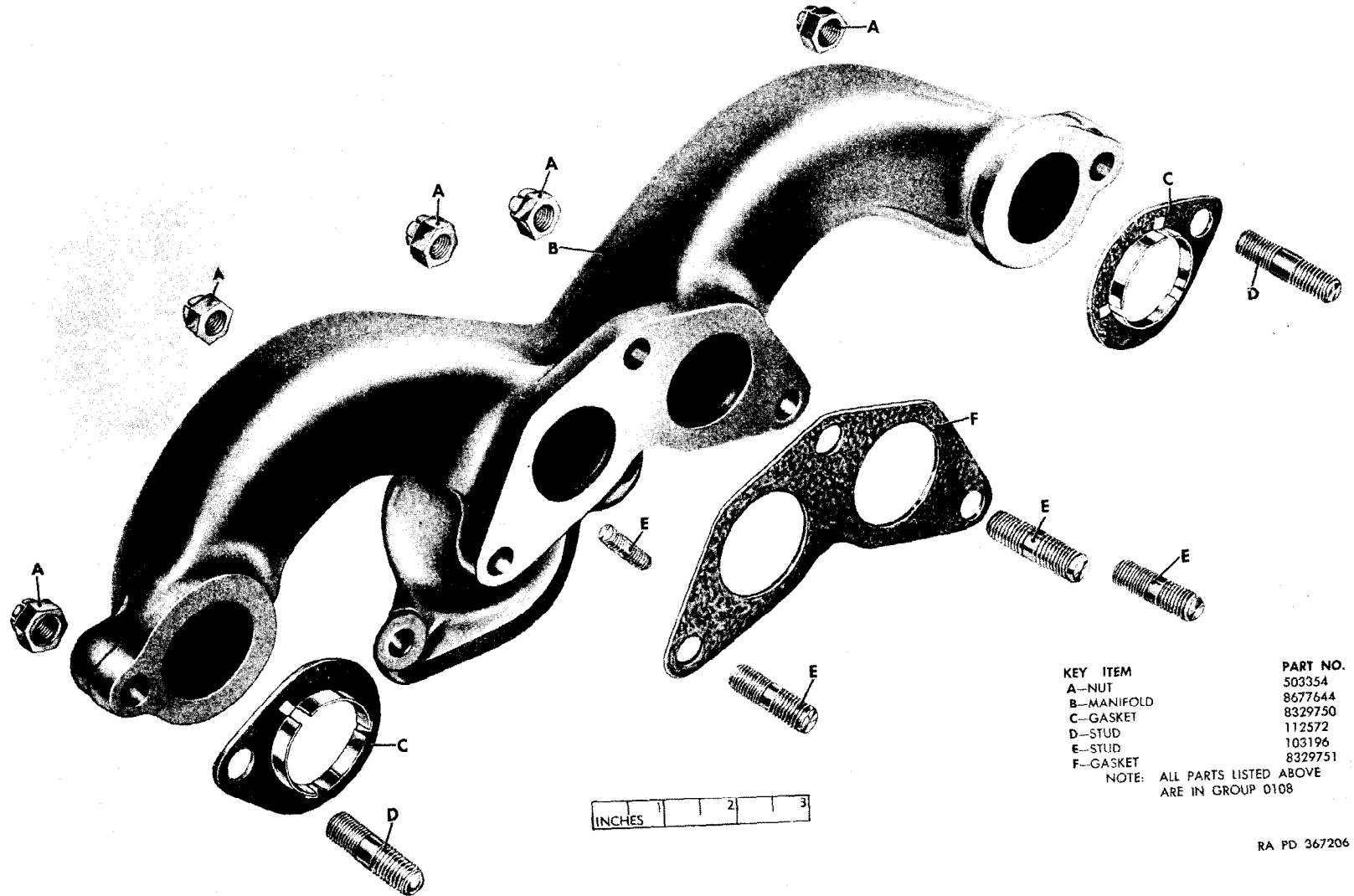

RA PD 367206

Figure 01-14. Exhaust manifold—exploded view

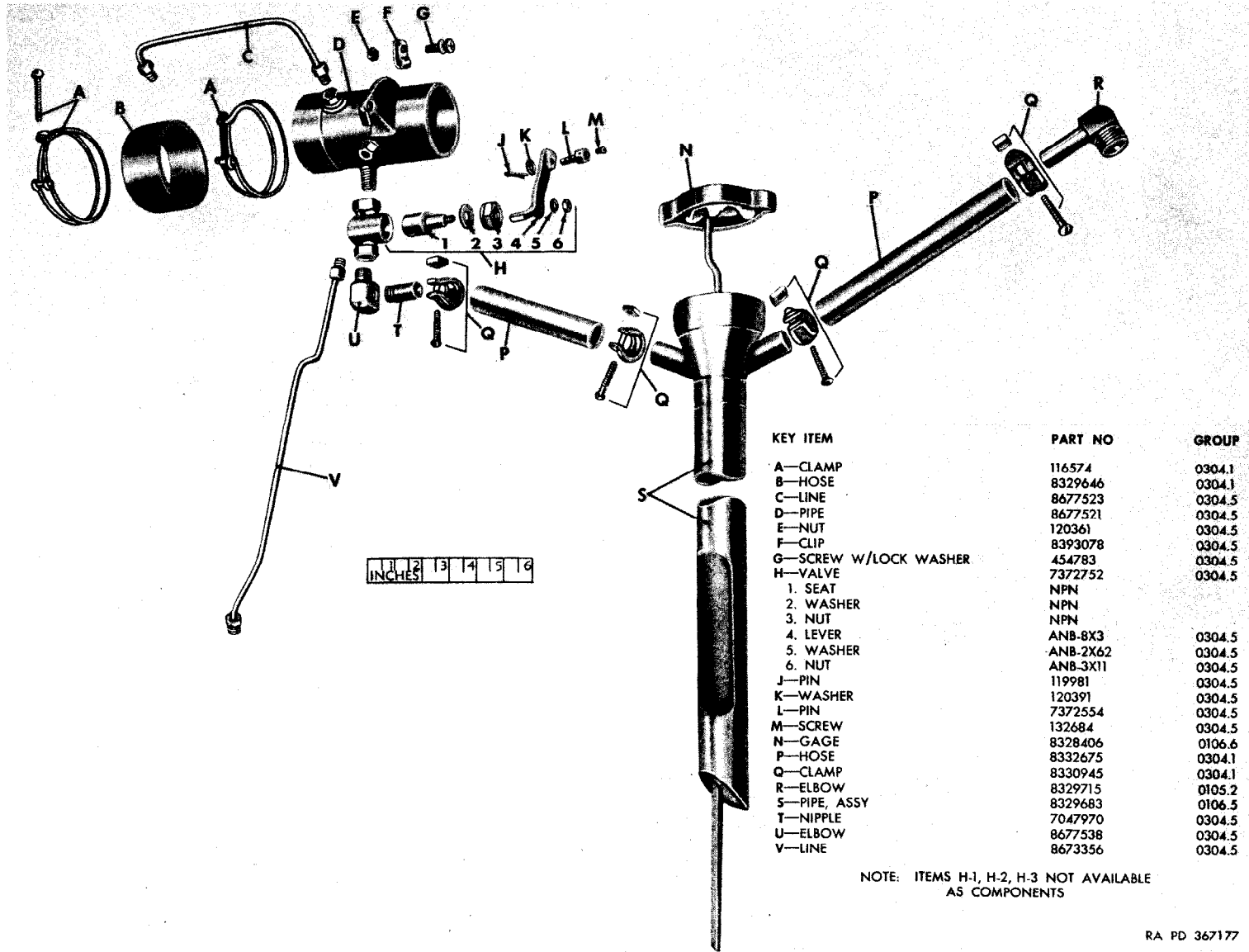
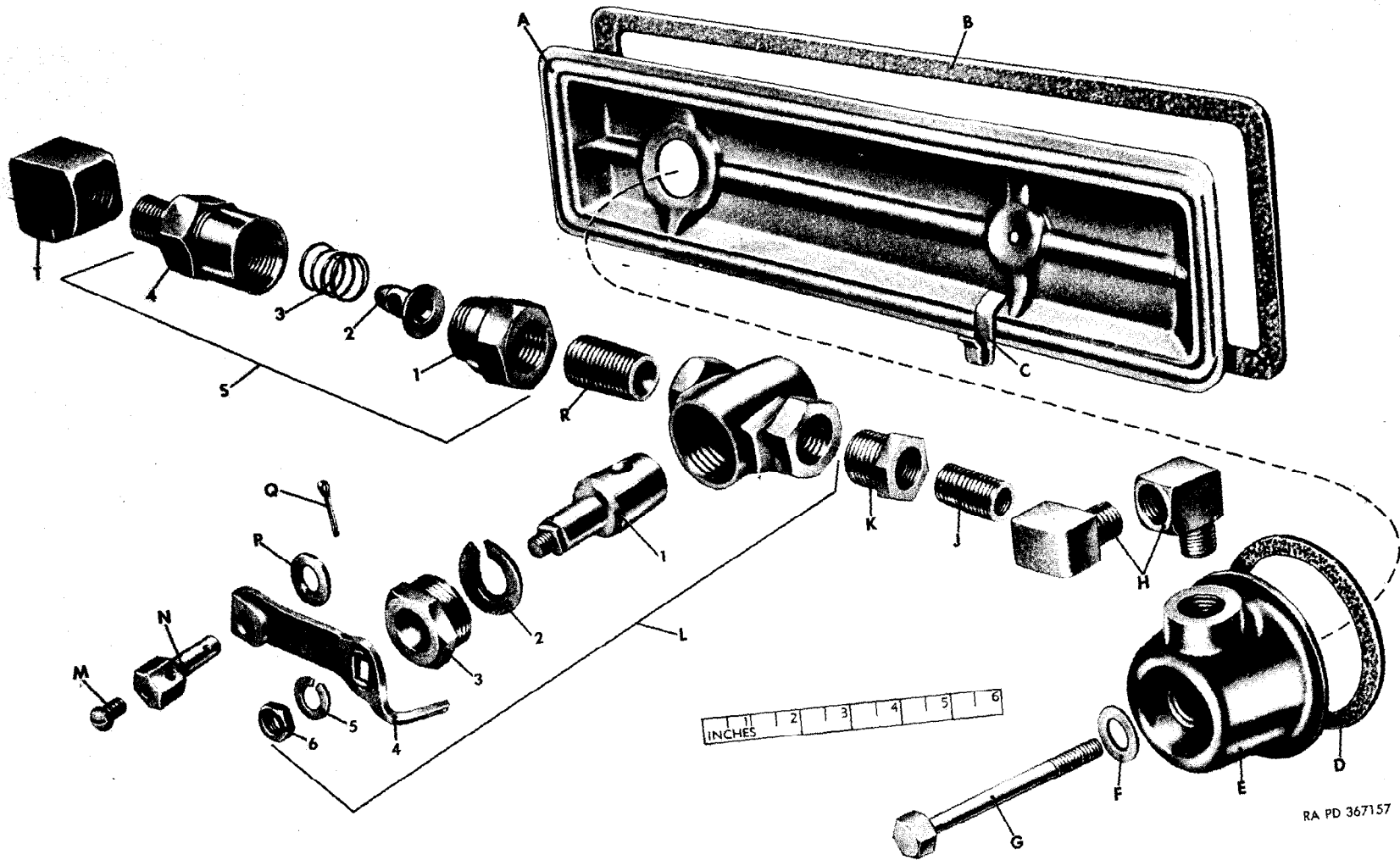

Figure 01-15. Upper vent system—exploded view



RA PD 367157

Figure 01-16. Lower vent system—exploded view

| <i>Key</i> | <i>Item</i> | <i>Part No.</i> | <i>Group</i> |
|------------|------------------|-----------------|--------------|
| A | -COVER..... | 7371237 | 0105.1 |
| B | -GASKET..... | FM-GPW6521 | 0105.1 |
| C | -CLIP..... | WO-807709 | 0105.1 |
| D | -GASKET..... | 7371272 | 0106.5 |
| E | -VENTILATOR..... | 7371286 | 0106.5 |
| F | -GASKET..... | 8329873 | 0105.1 |
| G | -SCREW..... | 7741420 | 0105.1 |
| H | -ELBOW..... | WO-809656 | 0106.5 |
| J | -NIPPLE..... | 192032 | 0304.5 |
| K | -BUSHING..... | 144035 | 0304.5 |
| L | -VALVE..... | 7372752 | 0304.5 |
| | 1-SEAT..... | NPN | |
| | 2-WASHER..... | NPN | |
| | 3-NUT..... | NPN | |
| | 4-LEVER..... | ANB-8X3 | 0304.5 |
| | 5-WASHER..... | ANB-2X62 | 0304.5 |
| | 6-NUT..... | ANB-3X11 | 0304.5 |
| M | -SCREW..... | 132684 | 0304.5 |
| N | -PIN..... | 7372554 | 0304.5 |
| P | -WASHER..... | 120391 | 0304.5 |
| Q | -PIN..... | 119981 | 0304.5 |
| R | -NIPPLE..... | 192050 | 0304.5 |
| S | -VALVE..... | 5336400 | 0304.5 |
| | 1-RETAINER..... | B246309 | 0304.5 |
| | 2-VALVE..... | A291788 | 0304.5 |
| | 3-SPRING..... | 5291787 | 0304.5 |
| | 4-BODY..... | AC-1543013 | 0304.5 |
| T | -ELBOW..... | 8329637 | 0304.5 |

Figure 01-16. Lower vent system—legend

0100.1

34

| (1) | (2) | (3) | (4) | (5) | (6) | (7) | (8) | (9) |
|------------------|-------------------|---------------------------|--|-------------------------------------|--|--|-------------------------------|----------------------|
| ILLUSTRATION NO. | REFERENCE SYMBOLS | FEDERAL STOCK NO. | ORDNANCE STOCK NO. | MFR'S PART NO. | ORDNANCE PART NO. | DESCRIPTION | QUANTITY INCORPORATED IN UNIT | UNIT OF ISSUE |
| 01-1, 3, 4 | | | G758-8328396 G758-8332071 | WO-804766 WO-808476 WO-808666 | 8328396 8332071 | GROUP 01-ENGINE 0100.1-POWER PLANT ASSEMBLY HOOK, engine lifting (superseded by HOOK 8332071)..... HOOK, engine lifting (supersedes HOOK 8328396)..... POWER PLANT, assy (ready to operate) (includes fuel PUMP, CARBURETOR, DISTRIBUTOR, spark PLUGS, oil PUMP, oil FILTER, water PUMP, THERMOSTAT, FAN, fan BELTS, CLUTCH, FLYWHEEL, flywheel HOUSING, GENERATOR, STARTER, TRANSMISSION, and TRANSFER) | 1 1 1 | ea ea ea |
| | H1 | 2805-737-2544 | G740-7372544 H101-9409110 | WO-800809 | 7372544 9409110 | 0100.2-ENGINE ASSEMBLY BRACKET, mounting, rear..... BOLT, assembled washer, hex-hd, split lock washer, S, cd- or zn-pltd, $\frac{3}{8}$ -16UNC-2A x $\frac{5}{8}$ | 1 4 | ea ea |
| | H1 | 2805-737-2545 010-4097 | G740-7372545 H001-0924218 G740-8328043 H101-0271193 | WO-649707 WO-804488 | 7372545 104097 8328043 271193 | BRACKET, stay cable, rear..... RIVET, b-hd, solid, S, $\frac{5}{16}$ x $\frac{3}{4}$ CABLE, stay (between engine and transmission)..... NUT, hex, lt, ext-teeth lock washer, S, cd- or zn-pltd, $\frac{3}{8}$ -24NF-2B | 1 1 1 2 | ea ea ea ea |
| 01-1, 2, 7 | H1 | 012-0213 | G758-8328391 H001-5419841 | WO-805522 | 8328391 120213 | CUSHION, front mounting support..... BOLT, MACHINE, cap, hex-hd, S, cd- or zn-pltd, $\frac{5}{16}$ -24UNF-2A x $\frac{1}{8}$ | 2 4 | ea ea |
| 01-7 | H1 | | H101-0271187 | | 271187 | NUT, hex, lt, ext-teeth lock washer, S, cd- or zn-pltd, $\frac{5}{16}$ -24NF-2B | 4 | ea |
| | H1 | | H101-0442832 | | 442832 | NUT, safety ("Huglock" lt, thk), S, cd- or zn-pltd, $\frac{1}{2}$ -20UNF-2B | 2 | ea |
| | H1 | 5310-012-0393 | H001-7043711 | | 120393 | WASHER, FLAT, S, cd- or zn-pltd, $1\frac{1}{32}$ ID, $1\frac{1}{16}$ OD, 0.065 thk | 3 | ea |
| | H1 | | H001-7124911 | | 178532 | WASHER, LOCK, int-ext-teeth, S, cd- or zn-pltd, $\frac{3}{16}$ x 0.900 OD | 1 | ea |
| | H1 | 2805-737-2551 | G740-7372551 H101-0271193 | WO-801053 | 7372551 271193 | CUSHION, rear mounting support..... NUT, hex, lt, ext-teeth-lock washer, S, cd- or zn-pltd, $\frac{3}{8}$ -24NF-2B | 1 2 | ea ea |
| | H1 | | | | 442828 | NUT, lock, hex, S, cd- or zn-pltd, $\frac{3}{8}$ -24NF-2..... | 2 | ea |
| | H1 | 5310-012-0394 | H001-7043741 | | 120394 | WASHER, FLAT, S, cd- or zn-pltd, $1\frac{1}{32}$ ID, $1\frac{1}{16}$ OD, 0.065 thk | 2 | ea |
| | H1 | 5310-012-0388 | H001-7045591 | | 120388 | WASHER, FLAT, S, cd- or zn-pltd, $\frac{1}{16}$ ID, 1 OD, 0.083 thk | 2 | ea |

| | | | | | | | | |
|------------|----|---------------|-------------------------------------|---------|--|----|----|--|
| | | | WO-806879 | | ENGINE, w/FLYWHEEL and flywheel HOUSING, less CLUTCH, assy | 1 | ea | |
| 01-1, 2 | | G758-8328393 | WO-806878 | 8328393 | ENGINE, w/ACCESSORIES, assy (includes fuel PUMP, CARBURETOR, DISTRIBUTOR, spark PLUGS, oil PUMP, oil FILTER, water PUMP, THERMOSTAT, FAN, fan BELTS, CLUTCH, FLYWHEEL, flywheel HOUSING, GENERATOR, and STARTER) | 1 | ea | |
| | | | WO-806876 | | ENGINE, w/ACCESSORIES, assy (same as ENGINE 8328393, w/o CLUTCH and flywheel HOUSING) | 1 | ea | |
| | | | 0101—CYLINDER BLOCK AND HEAD | | | | | |
| | | | WO-806279 | 8677623 | BLOCK, cylinder | 1 | ea | |
| | | | WO-806877 | | BLOCK, cylinder, assy (short) | 1 | ea | |
| 01-3, 7 | | | WO-806281 | 8677621 | BLOCK, cylinder, w/BEARINGS, assy | 1 | ea | |
| | | | WO-806280 | 8677622 | BLOCK, cylinder, w/crankshaft bearing CAPS, PLUGS, and valve GUIDES, assy | 1 | ea | |
| | H6 | | H106-0103647 | 103647 | COCK, drain, tee-handle, br, 1/4 in. male pipe end (type C) | 1 | ea | |
| 01-3, 4 | | G758-8328463 | VG-1057 | 8328463 | GASKET, cylinder head | 1 | ea | |
| | | | WO-807036 | | | | | |
| 01-5 | | | WO-807005 | 8677437 | HEAD, cylinder | 1 | ea | |
| | | | G758-8329676 | 8329676 | BOLT, hex-hd, 7/16-14NC-3 x 1 1/16 | 1 | ea | |
| | | | G758-8329677 | 8329677 | SCREW, 7/16-14NC-3 x 4 1/4 | 12 | ea | |
| | | | G758-8329678 | 8329678 | SCREW, hex-hd, 7/16-14NC-3 x 4 5/8 (at engine lift hook) | 2 | ea | |
| | | 5310-276-3455 | G758-8329680 | 8329680 | WASHER, FLAT, S, cd- or zn-pltd, 1 5/32 ID, 1 OD, 1/8 thk (superseded by WASHER 103342) | 11 | ea | |
| | H1 | | H001-1530010 | 103342 | WASHER, FLAT, S, fin, 1 5/32 ID, 1 5/16 OD, 1/16 thk (supersedes WASHER 8329680) | 11 | ea | |
| 01-3, 4, 5 | | G758-8328474 | WO-806266 | 8328474 | HEAD, cylinder, w/CONNECTOR, GUIDES, NIPPLE, PLUGS, and STUDS, assy | 1 | ea | |
| | | | WO-806288 | 8673354 | HEAD, cylinder, w/THERMOSTAT, HOUSING, water temperature sending UNIT, assy | 1 | ea | |
| | | | WO-907878 | | PLUG, expansion, S, 1 1/4 in. dia (cylinder block, RH side) | 2 | ea | |
| | | | G758-8329675 | 8329675 | PLUG, pipe, dld-sq-hd, S, 1/8-27NPT (superseded by PLUG 117243) (main oil gallery) | 1 | ea | |
| 01-5 | H6 | 014-3993 | H006-0288569 | 143933 | PLUG, PIPE, sq-hd, CI, cd- or zn-pltd, 1/4 in. (plug holes in cylinder head for primer fittings) | 2 | ea | |
| | H6 | 010-3865 | H006-0288566 | 103865 | PLUG, PIPE, sq-hd, CI, 1/8 in. (oil filter hole) | 2 | ea | |
| 01-5 | H6 | 010-3868 | H006-0288571 | 103868 | PLUG, PIPE, sq-hd, CI, 1/2 in. (optional w/PLUG 103880) (heat indicator hole in cylinder head) | 1 | ea | |
| | H6 | | H106-0117243 | 117243 | PLUG, pipe, sq-hd, S, cd- or zn-pltd, 1/8 in. (supersedes PLUG 8329675) (main oil gallery) | 1 | ea | |
| 01-5 | H6 | 010-3877 | H006-0288956 | 103877 | PLUG, pipe, sq-hd, S, 1/8 in. (main oil gallery) | 1 | ea | |

| (1) ILLUSTRATION NO. | (2) REFERENCE SYMBOLS | (3) FEDERAL STOCK NO. | (4) ORDNANCE STOCK NO. | (5) MFR'S PART NO. | (6) ORDNANCE PART NO. | (7) DESCRIPTION | (8) QUANTITY INCORPORATED IN UNIT | (9) UNIT OF ISSUE |
|---|--------------------------|--------------------------|---------------------------|------------------------------------|--------------------------|---|--------------------------------------|----------------------|
| GROUP 01—ENGINE—Continued | | | | | | | | |
| 0101—CYLINDER BLOCK AND HEAD—Continued | | | | | | | | |
| 01-5, 9 | H6 | 010-3880 | H106-0103880 | | 109880 | PLUG, PIPE, sq-hd, S, 1/2 in. (optional w/PLUG 103868) (heat indicator hole in cylinder head) | 1 | ea |
| | H6 | 011-3185 | H006-0283755 | | 113185 | PLUG, PIPE, sq-socket, hdls, MI, 3/8 in. (main oil gallery) | 2 | ea |
| | | | G758-8329679 | WO-649708 | 8329679 | STUD, rocker arm shaft support (part of HEAD assy 8328474) | 4 | ea |
| | H1 | | H101-0103151 | | 103151 | STUD, S, 1/4-20NC (3/8) x 1/4-28NF-2 (1/2) x 1 (hole plugs in block) | 2 | ea |
| 0102.1—CRANKSHAFT | | | | | | | | |
| 01-3, 4, 6 | | | G716-8673476 | WO-646316 | 8673476 | CRANKSHAFT, w/COUNTERWEIGHT | 1 | ea |
| | | 2805-774-4473 | G503-7744473 | WO-647078 | 7744473 | CRANKSHAFT, w/flywheel BOLT, NUT, and WASHER, assy | 1 | ea |
| 01-3, 7 | | 2805-737-2558 | G740-7372558 | WO-649722 | 7372558 | PULLEY, drive, fan and generator (double V) | 1 | ea |
| 01-7 | H1 | 012-4549 | H001-0518022 | | 124549 | KEY, Woodruff, alloy-S, 3/16 x 3/4 (No. 606 or 9) | 1 | ea |
| 01-7 | | 5310-769-7864 | G503-7697864 | WO-638513 | 7697864 | NUT, hex, S, 1 1/16 | 1 | ea |
| 01-7 | | 2805-774-4469 | G503-7744469 | WO-643839 | 7744469 | SEAL, oil, front, 1 3/4 in. (superseded by SEAL 7375028) | 1 | ea |
| | | 2805-737-5028 | G740-7375028 | CM-15485A VG-49575 WO-647468 | 7375028 | SEAL, oil, front, 1 3/4 in. (supersedes SEAL, 7744469) | 1 | ea |
| | | 2805-737-2560 | G740-7372560 | VG-49650 WO-800093 | 7372560 | SEAL, oil, rear, upper and lower | 2 | ea |
| 01-3 | | 2855-360-8062 | G503-7371376 | WO-A1124 | 7371376 | SHIELD, pulley | 1 | ea |
| 01-11 | H1 | 042-3563 | H101-0423563 | | 423563 | BOLT, INTEGRAL LOCK WASHER, hex-hd, S, cd-or zn-pltd, 5/16-18NC-2 x 1 1/8 | 6 | ea |
| 01-6 | | 2805-360-7886 | G503-7371226 | WO-630262 | 7371226 | SHIM, adjusting, 0.002 in. thk (drive gear) | † | ea |
| 01-6, 7 | | | G503-7371161 | WO-375877 | 7371161 | SLINGER, oil | 1 | ea |
| | | 2930-737-2559 | G740-7372559 | WO-649849 | 7372559 | SPACER, fan pulley shield | 6 | ea |
| | | 5310-360-8064 | G503-7743818 | WO-A6701 | 7743818 | WASHER, cloth, 1/4 ID, 5/16 OD, 0.005 thk (fan pulley shield spacer) | 6 | ea |
| 01-6 | | 5310-360-7888 | G503-7371160 | WO-634796 | 7371160 | WASHER, thrust, S, 1.251 ID, 3 1/8 OD, 0.153 thk (drive gear) | 1 | ea |

0102.2—MAIN BEARINGS

01-6

2805-354-3789 G740-7372565 WO-645161 7372565
 2805-737-2568 G740-7372568 WO-645164 7372568
 2805-495-9607 G740-7372571 WO-645167 7372571
 2805-495-9610 G740-7372574 WO-645170 7372574

BEARING, half, center..... 2 ea
 standard
 0.010 undersize
 0.020 undersize
 0.030 undersize

01-6

2805-737-2567 G740-7372564 WO-645160 7372564
 G740-7372567 WO-645163 7372567
 G740-7372570 WO-645166 7372570
 G740-7372573 WO-645169 7372573

BEARING, half, front..... 2 ea
 standard
 0.010 undersize
 0.020 undersize
 0.030 undersize

01-6

2805-354-3490 G740-7372566 WO-645162 7372566
 G740-7372569 WO-645165 7372569
 2805-495-9608 G740-7372572 WO-645168 7372572
 2805-495-9611 G740-7372575 WO-645171 7372575
 3120-423-3071 G503-7371493 WO-A6798 7371493

BEARING, half, rear..... 2 ea
 standard
 0.010 undersize
 0.020 undersize
 0.030 undersize

2805-360-7870 G503-7521218 WO-A6746 7371493
 7372564
 7372565
 7372566

BEARING SET, standard..... 1 ea
 Composed of:
 1 BEARING
 1 BEARING
 1 BEARING

2805-737-1503 G503-7371503 WO-A6747 7521218
 7372567
 7372568
 7372569

BEARING SET, 0.010 undersize..... 1 ea
 Composed of:
 1 BEARING
 1 BEARING
 1 BEARING

3120-360-7879 G503-7371504 WO-A6748 7371503
 7372570
 7372571
 7372572

BEARING SET, 0.020 undersize..... 1 ea
 Composed of:
 1 BEARING
 1 BEARING
 1 BEARING

5305-360-4509 G503-7371227 WO-630288
 5310-012-0384 H001-7025801 WO-630285
 5330-360-7882 G503-7371281 WO-637236
 5305-360-7880 G503-7371229 WO-381519
 WO-637790
 WO-635377

BEARING SET, 0.030 undersize..... 1 ea
 Composed of:
 1 BEARING
 1 BEARING
 1 BEARING

CAP, bearing, center..... 1 ea
 CAP, bearing, front..... 1 ea
 CAP, bearing, rear..... 1 ea
 SCREW, cap, hex-hd, 1/2-13NC-2 x 3/8..... 6 ea
 WASHER, LOCK, med, S, cd- or zn-pltd, 1/2 in..... 6 ea

PACKING, rear bearing cap..... 2 ea
 PIN, dowel, bearing..... 5 ea

| (1) ILLUSTRATION NO. | (2) REFER- ENCE SYMBOLS | (3) FEDERAL STOCK NO. | (4) ORDNANCE STOCK NO. | (5) MFR'S PART NO. | (6) ORDNANCE PART NO. | (7) DESCRIPTION | (8) QUANTITY INCOR- PORATED IN UNIT | (9) UNIT OF ISSUE |
|------------------------------------|----------------------------------|-----------------------------|------------------------------|--------------------------|-----------------------------|--|---|----------------------------|
| GROUP 01—ENGINE—Continued | | | | | | | | |
| 0103—FLYWHEEL AND RING GEAR | | | | | | | | |
| | | | | | | BEARING, bushing-type, clutch pilot (see subgroup 0201) | | |
| | H1 | | H101-0571263 | | 571263 | BOLT, MACHINE, cap, socket-hd, alloy-S, cd- or zn-pltd, 1/4-20NC-3 x 1/2 (seal support to rear engine plate) | 4 | ea |
| 01-7 | | | G740-8328310 | WO-804417 | 8328310 | COVER, inspection, clutch linkage (flywheel housing)..... | 1 | ea |
| 01-7 | H1 | | H101-9409106 | | 9409106 | BOLT, MACHINE, hex-hd, split lock washer, S, cd- or zn-pltd, 1/4-20UNC-2A x 1/2 | 6 | ea |
| | | | | WO-A1441 | 8677008 | FLYWHEEL..... | 1 | ea |
| 01-3 | | | | WO-804314 | | FLYWHEEL, assy..... | 1 | ea |
| | | | G740-8328045 | WO-805454 | 8328045 | FLYWHEEL, w/ring GEAR, assy..... | 1 | ea |
| 01-6 | | | G503-7324840 | WO-632157 | 7324840 | BOLT, hex-hd, S, 3/8-24NF-2 x 1 1/2..... | 4 | ea |
| | | | | WO-909393 | | NUT, hex, S, 3/8-24NF, spec..... | 6 | ea |
| 01-6 | | 5305-495-9562 | G503-7371231 | WO-632156 | 7371231 | PIN, dowel, tapered, engine flywheel to crankshaft..... | 2 | ea |
| | H1 | | H001-7017681 | | 138489 | WASHER, lock, ext-teeth, S, cd- or zn-pltd, 3/8 in..... | 6 | ea |
| 01-7 | | | G740-8328048 | WO-804377 | 8328048 | GASKET, bell housing to rear engine plate..... | 1 | ea |
| 01-7 | | | G740-8328313 | ACK-PD3100 WO-804418 | 8328313 | GASKET, clutch linkage inspection cover (flywheel housing) | 1 | ea |
| | | | | WO-804379 | 8328049 | GASKET, cylinder block to rear engine plate..... | 1 | ea |
| 01-7 | | | G740-8328049 | VG-2003 | 8330239 | GASKET, seal support to rear engine plate (1/4 in.)..... | 4 | ea |
| | | | | WO-807762 | | | | |
| | | | G740-8328046 | WO-802925 | 8328046 | GEAR, ring, flywheel..... | 1 | ea |
| | | | | WO-804306 | | HOUSING, flywheel..... | 1 | ea |
| 01-1, 7 | | | G740-8328312 | WO-804812 | 8328312 | HOUSING, flywheel, assy..... | 1 | ea |
| 01-7 | | | G740-8328311 | WO-804367 | 8328311 | BOLT, dowel, 3/8-24NF-3 x 3 3/8..... | 2 | ea |
| 01-7 | H1 | | H101-0271193 | | 271193 | NUT, hex, lt, ext-teeth-lock washer, cd- or zn-pltd, 3/8-24NF-2B (housing to engine plate to cylinder block (4), to engine plate to reinforcement (4)) | 8 | ea |
| 01-7 | H1 | 012-0640 | H101-0120640 | | 120640 | SCREW, cap, hex-hd, S, cd- or zn-pltd, 3/8-24NF-3 x 2 1/2 | 4 | ea |
| 01-7 | H1 | | H101-0124128 | | 124128 | SCREW, cap, hex-hd, S, cd- or zn-pltd, 3/8-24NF-3 x 3..... | 2 | ea |
| 01-3, 7 | | | G740-8328047 | WO-807889 | 8328047 | PLATE, end, engine, rear (cylinder block to bell housing)... | 1 | ea |
| 01-7 | H1 | | H001-5419861 | | 121661 | SCREW, cap, hex-hd, S, cd- or zn-pltd, 5/16-24NF-3 x 1..... | 6 | ea |
| 01-7 | | 5330-522-6060 | G102-0101396 | WIL-A11406X WO-805896 | A226060 | WASHER, sp, conical-concave, cop, 0.310 ID, 0.440 OD, 0.09 thk | 6 | ea |
| 01-7 | H6 | 010-3865 | H006-0283566 | | 103865 | PLUG, PIPE, sq-hd, CI, 1/8 in. (flywheel housing) (optional w/PLUG 103877) | 1 | ea |

| | | | | | | | | |
|------|----|--|--|--|--|--|---|----|
| | H6 | 010-3877 | H006-0283956 | | 103877 | PLUG, PIPE, sq-hd, S, 1/8 in. (flywheel housing) (optional w/PLUG 103865) | 1 | ea |
| | | | | WO-809304 | | POINTER, timing indicator (use after engines serial No. 49868) | 1 | ea |
| | | | G758-8328483 | WO-805767 | 8328483 | REINFORCEMENT, engine plate, rear, left..... | 1 | ea |
| | | | G758-8328484 | WO-805768 | 8328484 | REINFORCEMENT, engine plate, rear, right..... | 1 | ea |
| 20-4 | H1 | | H101-0103260 | | 103260 | STUD, S, 3/16-12NC-2 (7/8) x 3/16-18NF-2 (7/8) x 2 1/8 (plug, flywheel housing) (used to attach HANGER 7411681 listed in subgroup 2001.3 when winch is used) | 1 | ea |
| | H1 | | G740-8328125 | WO-804289 | 8328125 | SUPPORT, rear, cylinder block to rear engine plate..... | 1 | ea |
| | H1 | | H001-5419141 | | 122007 | SCREW, cap, hex-hd, S, cd- or zn-pltd, 3/16-18NC-3 x 3/4 | 2 | ea |
| | H1 | 5305-017-2427 | H101-0172427 | | 172427 | SCREW, TAPPING, hex-hd, fluted, taper-pt, S, cd- or zn-pltd, 1/4-20NC-2 x 1/2 | 4 | ea |
| | | | | | | 0104.1-PISTONS AND PISTON RINGS | | |
| 01-8 | | | G503-7324840 | WO-632157 | 7324840 | BOLT, hex-hd, S, 3/8-24NF-2 x 1 5/16 (locking, piston pin) | 4 | ea |
| 01-8 | H1 | 012-0382 | H001-7025741 | | 120382 | WASHER, lock, med, S, cd- or zn-pltd, 3/8 in..... | 4 | ea |
| | | | | SEPC-WAJ291 MNC-R1788C WO-116108 | 8677030 | EXPANDER, piston compression ring (intermediate) (for normal and extreme oil consumption std and 0.020 oversize ring) (superseded by RING PR-B1061C) | 4 | ea |
| | | | | SEPC-WAJ292 WO-116613 | | EXPANDER, piston compression ring (top) (for normal and extreme oil consumption 0.030 and 0.040 oversize ring) (superseded by RING PR-B1062C and PR-24929) | 4 | ea |
| | | | | PR-031E12A MNC-R5792 WO-806146 | | EXPANDER, piston oil regulating ring (bottom) (normal and extreme oil consumption) | 4 | ea |
| | | | | SEPC-WAJ294 MNC-R1787D WO-116109 | 8677031 | EXPANDER, piston oil regulating ring (bottom) (for normal and extreme oil consumption std ring) | 4 | ea |
| | | | | SEPC-WAJ304 WO-801492 | | EXPANDER, piston oil regulating ring (bottom) (for normal and extreme oil consumption 0.020, 0.030, and 0.040 oversize ring) | 4 | ea |
| | | | | SEPC-WAJ296 WO-801493 | | EXPANDER, piston oil regulating ring (bottom) (for normal and extreme oil consumption 0.020, 0.030, and 0.040 oversize ring) | 4 | ea |
| 01-8 | | 5305-360-4545 2805-737-1145 | G503-7371144 G503-7371145 | WO-636961 WO-116003 | 7371144 7371145 | PIN, piston standard 0.003 oversize | 4 | ea |
| 01-8 | | 2805-737-2873 2805-737-2874 2805-737-2875 2805-737-2876 | G740-7372873 G740-7372874 G740-7372875 G740-7372876 | WO-801476 WO-801538 WO-801539 WO-801540 | 7372873 7372874 7372875 7372876 | PISTON, w/PIN, assy standard 0.020 oversize 0.030 oversize 0.040 oversize | 4 | ea |

0104.1

| (1) ILLUSTRATION NO. | (2) REFER- ENCE SYMBOLS | (3) FEDERAL STOCK NO. | (4) ORDNANCE STOCK NO. | (5) MFR'S PART NO. | (6) ORDNANCE PART NO. | (7) DESCRIPTION | (8) QUANTITY INCOR- PORATED IN UNIT | (9) UNIT OF ISSUE | |
|--|----------------------------------|-----------------------------|------------------------------|-----------------------|-----------------------------|--|--|----------------------------|----|
| GROUP 01—ENGINE—Continued | | | | | | | | | |
| 0104.1—PISTONS AND PISTON RINGS—Continued | | | | | | | | | |
| 01-8 | | | | WO-801371 | | PISTON, w/o PIN | 4 | ea | |
| | | | | WO-801534 | | standard | | | |
| | | | | WO-801535 | | 0.020 oversize | | | |
| | | | | WO-801536 | | 0.030 oversize | | | |
| | | | | WO-809021 | | 0.040 oversize | 4 | ea | |
| | | | | | | RING, oil regulating, piston (0.020 oversize), w/EX- PANDER, assy (bottom) (normal oil consumption) | | | |
| | | | | | PR-031E12A | | Composed of: | 4 | ea |
| | | | | | PR-X4071A | | 1 EXPANDER | | |
| | | | | | WO-809022 | | 1 RING | 4 | ea |
| | | | | | | | RING, oil regulating, piston (0.030 oversize), w/EX- PANDER, assy (bottom) (normal oil consumption) | | |
| | | | | PR-031E12A | | Composed of: | 1 | ea | |
| | | | | PR-X4072A | | 1 EXPANDER | | | |
| | | | | WO-809023 | | 1 RING | 4 | ea | |
| | | | | | | RING, oil regulating, piston (0.040 oversize), w/EX- PANDER, assy (bottom) (normal oil consumption) | | | |
| | | | | PR-031E12A | | Composed of: | 4 | ea | |
| | | | | PR-X4073A | | 1 EXPANDER | | | |
| 01-8 | | | | | | 1 RING | 4 | ea | |
| | | | | | | RING, piston, bottom groove, | | | |
| | | | | | FM-GPW6156F | | standard | 4 | ea |
| | | | | | SEPC-WAJ247 | | | | |
| | | | | | WO-116616 | | | | |
| | | | | | FM-GPW6156H | | 0.020 oversize | | |
| | | | | | SEPC-WAJ247C | | | | |
| | | | | | WO-116116 | | | | |
| | | | | | SEPC-WAJ247D | | 0.030 oversize | | |
| | | | | | WO-116117 | | | | |
| | | | | SEPC-WAJ247E | | 0.040 oversize | | | |
| | | | | WO-116705 | | | | | |
| | | | | SEPC-WAJ293 | | RING, piston, bottom groove (extreme oil consumption), | 4 | ea | |
| | | | | MNC-R5153B | | standard | | | |
| | | | | STD | | | 4 | ea | |
| | | | | WO-801480 | | | | | |
| | | | | MNC-R5153B020 | | 0.020 oversize | | | |
| | | | | WO-119022 | | | | | |

40

| | | | |
|--|--|---|----|
| MNC-R5153D WO-119023 | 0.030 oversize | | |
| MNC-R5153B040 WO-119024 | 0.040 oversize | | |
| SEPC-WAJ298 WO-636148 | RING, piston, bottom groove (normal oil consumption), standard (superseded by RING SEPC-WAJ293) | 4 | ea |
| SEPC-WAJ293 WO-801480 | standard (supersedes RING SEPC-WAJ298) (super- seded by RING PR-B1060C) | | |
| PR-B1060C WO-806144 | standard (supersedes RING SEPC-WAJ293) | | |
| SEPC-WAJ298C WO-115796 | 0.020 oversize (superseded by RING PR-X4071A) | | |
| PR-X4071A WO-809025 | 0.020 oversize (supersedes RING SEPC-WAJ298C) | | |
| SEPC-WAJ298D WO-115797 | 0.030 oversize (superseded by RING PR-X4072A) | | |
| PR-X4072A WO-809026 | 0.030 oversize (supersedes RING SEPC-WAJ298D) | | |
| SEPC-WAJ298E WO-115798 | 0.040 oversize (superseded by RING PR-X4073A) | | |
| PR-X4073A WO-809027 | 0.040 oversize (supersedes RING SEPC-WAJ298E) | | |
| FM-GPW6155A SEPC-WAJ211 WO-637042 | RING, piston, compression, second groove, standard (superseded by RING SEPC-WAJ297) | 4 | ea |
| FM-GPW6155G SEPC-WAJ211C WO-116023 | 0.020 oversize (superseded by RING SEPC-WAJ297C) | | |
| FM-GPW6155H SEPC-WAJ211D WO-116024 | 0.030 oversize (superseded by RING SEPC-WAJ297D) | | |
| SEPC-WAJ211E WO-116704 | 0.040 oversize (superseded by RING SEPC-WAJ297E) | | |
| SEPC-WAJ297 WO-116058 | RING, piston, compression, second groove, standard (superseded by RING PR-72A367) | 4 | ea |
| PR-72A367 WO-806145 | standard (supersedes RING SEPC-WAJ297) | | |
| SEPC-WAJ297C WO-116060 | 0.020 oversize (superseded by RING PR-B1061C) | | |
| PR-B1061C WO-808797 | 0.020 oversize (supersedes RING SEPC-WAJ297C and EXPANDER 8677030) | | |
| SEPC-WAJ297D WO-116061 | 0.030 oversize (superseded by RING PR-B1062C) | | |

0104.1

| (1) ILLUSTRATION NO. | (2) REFERENCE SYMBOLS | (3) FEDERAL STOCK NO. | (4) ORDNANCE STOCK NO. | (5) MFR'S PART NO. | (6) ORDNANCE PART NO. | (7) DESCRIPTION | (8) QUANTITY INCORPORATED IN UNIT | (9) UNIT OF ISSUE | |
|--|--------------------------|--------------------------|---------------------------|--|--|---|--|----------------------|----|
| GROUP 01—ENGINE—Continued | | | | | | | | | |
| 0104.1—PISTONS AND PISTON RINGS—Continued | | | | | | | | | |
| RING—Continued | | | | | | | | | |
| 01-8 | | | | PR-B1062C WO-808798 SEPC-WAJ297E WO-116708 PR-24929 WO-808799 | 8677512 | 0.030 oversize (supersedes RING SEPC-WAJ297D and EXPANDER SEPC-WAJ292) 0.040 oversize (superseded by RING PR-24929) 0.040 oversize (supersedes RING SEPC-WAJ297E and EXPANDER SEPC-WAJ292) RING, piston, compression, top groove,..... | 4 | ea | |
| | | | | FM-GPW6150A SEPC-WAJ239 WO-639864 PR-B2531A WO-806143 FM-GPW6150C SPEC-WAJ239C WO-116502 PR-B2532A WO-808793 FM-GPW6150D SEPC-WAJ239D WO-116503 PR-B2533A WO-808794 SEPC-WAJ239E WO-116703 PR-B2534A WO-808795 | | standard (superseded by RING PR-B2531A) standard (supersedes RING SEPC-WAJ239) 0.020 oversize (superseded by RING PR-B2532A) 0.020 oversize (supersedes RING SEPC-WAJ239C) 0.030 oversize (superseded by RING PR-B2533A) 0.030 oversize (supersedes RING SEPC-WAJ239D) 0.040 oversize (superseded by RING PR-B2534A) 0.040 oversize (supersedes RING SEPC-WAJ239E) | | | |
| | | | 2805-360-7893 | G503-7371146 | SEPC-863 WO-A6794 | 7371146 | RING SET, piston, conventional type, standard..... | 1 | ea |
| | | | | G503-7330714 | WO-639864 WO-637042 WO-116616 WO-A6796 PR-B2532A | 7330714 | Composed of: 4 RING 4 RING 4 RING RING SET, piston, conventional type, 0.020 oversize..... Composed of: 4 RING | 1 | ea |

42

| | | | | | | |
|---------------|--------------|---|--------------------|--|---|----|
| 2805-360-7899 | G503-7371147 | SEPC-WAJ211C SEPC-WAJ247C WO-A6797 | 7371147 | 4 RING 4 RING RING SET, piston, conventional type, 0.030 oversize..... Composed of: 4 RING 4 RING 4 RING | 1 | ea |
| 2805-732-9277 | G503-7329277 | PR-B2533A SEPC-WAJ211D SEPC-WAJ247D WO-A15283 | 7329277 | RING SET, piston, conventional type, 0.040 oversize (superseded by RING SET 7418112) Composed of: 4 RING 4 RING 4 RING | 1 | ea |
| | | PR-B2534A SEPC-WAJ211E SEPC-WAJ247E SEPC-535 WO-116110 | 8393084 | RING SET, piston, normal oil consumption, standard (optional with RING SET PR-68-4) Composed of: 4 EXPANDER 4 EXPANDER | 1 | ea |
| | | SEPC-WAJ239 SEPC-WAJ297 SEPC-WAJ293 | 8677030 8677031 | 4 RING 4 RING 4 RING | | |
| | G780-7418111 | SEPC-535G WO-116112 | 7418111 | RING SET, piston, normal oil consumption, 0.020 over- size (optional with RING SET PR-68-4 +.020) Composed of: 4 EXPANDER 4 EXPANDER | 1 | ea |
| | | SEPC-WAJ304 PR-B2532A PR-B1061C SEPC-WAJ298C SEPC-535D WO-116113 | 8677030 | 4 RING 4 RING 4 RING RING SET, piston, normal oil consumption, 0.030 over- size (optional with RING SET PR-68-4 +.030) Composed of: 4 EXPANDER 4 EXPANDER | 1 | ea |
| | G780-7418112 | SEPC-WAJ292 SEPC-WAJ304 PR-B2533A PR-B1062C PR-X4072A SEPC-535E WO-116706 | 7418112 | 4 RING 4 RING RING SET, piston, normal oil consumption, 0.040 over- size (optional with RING SET PR-68-4 +.040) Composed of: 4 EXPANDER 4 EXPANDER | 1 | ea |
| | | SEPC-WAJ292 SEPC-WAJ304 PR-24929 PR-X4073A PR-B2534A | | 4 RING 4 RING 4 RING | | |

| (1) ILLUSTRATION NO. | (2) REFER- ENCE SYMBOLS | (3) FEDERAL STOCK NO. | (4) ORDNANCE STOCK NO. | (5) MFR'S PART NO. | (6) ORDNANCE PART NO. | (7) DESCRIPTION | (8) QUANTITY INCOR- PORATED IN UNIT | (9) UNIT OF ISSUE |
|--|----------------------------------|-----------------------------|------------------------------|---|-----------------------------|--|---|----------------------------|
| GROUP 01—ENGINE—Continued | | | | | | | | |
| 0104.1—PISTONS AND PISTON RINGS—Continued | | | | | | | | |
| | | | | PR-68-4 WO-809045 | | RING SET, normal oil consumption, standard, cr-pltd (optional with RING SET 8393084) Composed of: 4 RING 4 RING 4 RING | 1 | ea |
| | | | | PR-B2531A PR-B1060C PR-72A367 PR-68-4 +.020 WO-809047 | | RING SET, piston, normal oil consumption, 0.020 over- size, cr-pltd (optional with RING SET 7418111) Composed of: 4 RING 4 RING 4 RING w/EXPANDER | 1 | ea |
| | | | | PR-B2532A PR-B1061C WO-809021 PR-68-4 +.030 WO-809048 | | RING SET, piston, normal oil consumption, 0.030 over- size, cr-pltd (optional with RING SET SEPC-535D) Composed of: 4 RING 4 RING 4 RING w/EXPANDER | 1 | ea |
| | | | | PR-B2533A PR-B1062C WO-809022 PR-68-4 +.040 WO-809049 | | RING SET, piston, normal oil consumption, 0.040 over- size, cr-pltd (optional with RING SET 7418112) Composed of: 4 RING 4 RING 4 RING w/EXPANDER | 1 | ea |
| | | | G780-7418113 | PR-24928 PR-24929 PR-72A367 SEPC-535X WO-801500 | 7418113 | RING SET, piston, extreme oil consumption, standard..... Composed of: 4 EXPANDER 4 EXPANDER 4 RING 4 RING 4 RING 8 SEGMENT | 1 | ea |
| | | | G780-7418114 | SEPC-WAJ297 SEPC-WAJ293 SEPC-WAJ239 SEPC-WAJ295 SEPC-535XB WO-801502 | 7418114 8677030 | RING SET, piston, extreme oil consumption, 0.020 oversize Composed of: 4 EXPANDER | 1 | ea |

| (1) ILLUSTRATION NO. | (2) REFER- ENCE SYMBOLS | (3) FEDERAL STOCK NO. | (4) ORDNANCE STOCK NO. | (5) MFR'S PART NO. | (6) ORDNANCE PART NO. | (7) DESCRIPTION | (8) QUANTITY INCOR- PORATED IN UNIT | (9) UNIT OF ISSUE |
|---|----------------------------------|-----------------------------|------------------------------|-----------------------|-----------------------------|---|---|----------------------------|
| GROUP 01—ENGINE—Continued | | | | | | | | |
| 0104.2—CONNECTING RODS AND BEARINGS —Continued | | | | | | | | |
| 01-3, 4, 8 | | 2805-360-7912 | G503-7743751 | WO-641770 | 8673393 | ROD, connecting (for Nos. 1 and 3 cylinders)..... | 2 | ea |
| | | | | WO-641771 | | ROD, connecting (for Nos. 2 and 4 cylinders)..... | 2 | ea |
| | | | | WO-641772 | 8677015 | ROD, connecting, w/BEARING and CAP, assy (for Nos. 1 and 3 cylinders) | 2 | ea |
| | | | | WO-641773 | | ROD, connecting, w/BEARING and CAP, assy (for Nos. 2 and 4 cylinders) | 2 | ea |
| 01-3, 4, 8 | | 2805-354-3784 | G503-7743752 | WO-641774 | 7743751 | ROD, connecting, w/o BEARING and CAP, assy (for Nos. 1 and 3 cylinders) | 2 | ea |
| | | | | WO-641775 | 7743752 | ROD, connecting, w/o BEARING and CAP, assy (for Nos. 2 and 4 cylinders) | 2 | ea |
| 0105.1—VALVES, SPRINGS, AND GUIDES | | | | | | | | |
| 01-9 | | 2805-737-5032 | G740-7375032 | EAT-K292 | 7375032 | CAP, rotation, exhaust valve (used on engines through serial No. 97653) | 4 | ea |
| | | | | WO-800827 | | | | |
| 01-9 | | | G716-8329518 | TP-FR-RA58A | 8329518 | CAP, rotation, exhaust valve (used on engines after serial No. 97653) | 4 | ea |
| 01-16 | | | | WO-802587 | | | | |
| 01-16 | | | | WO-807709 | | CLIP, open, S, cd- or zn-pltd, 5/16 drum tube (welded) (valve spring cover) (fuel pump to clutch housing pressurizing line) | 1 | ea |
| 01-16 | | 2805-354-3763 | G503-7371237 | WO-630303 | 7371237 | COVER, valve spring..... | 1 | ea |
| | | | | WO-807708 | | COVER, valve spring, w/CLIP, assy..... | 1 | ea |
| 01-9, 16 | | | G503-0194032 | DGM-5201 | 8329873 | GASKET, 5/16 ID, 1/2 OD, 3/32 thk..... | 2 | ea |
| 01-16 | | | G503-7741420 | WO-51875 | | | | |
| | | | | WO-645093 | 7741420 | SCREW, cap, hex-hd, S, 5/16-18NC-2 x 3 1/16..... | 1 | ea |
| 01-16 | | | G758-8329696 | WO-806348 | 8329696 | STUD, spec, S, 5/16-18NC-3 x 5/8..... | 1 | ea |
| | | | | WO-807707 | 8677537 | COVER, valve spring, w/CLIP, and GASKET, assy..... | 1 | ea |
| 01-16 | | | G503-0194022 | FM-GPW6521 | | GASKET, valve spring cover..... | 1 | ea |
| | | | | WO-630305 | | | | |
| 01-5 | | 2805-737-5033 | G740-8328126 | WO-119137 | 8328126 | GUIDE, exhaust valve stem..... | 4 | ea |
| | | | | G758-8329691 | 8329691 | GUIDE, intake valve stem..... | 4 | ea |
| 01-9 | | | G740-7375033 | EAT-K630 | 7375033 | LOCK, valve spring retainer (exhaust) (used on engines through serial No. 97653) | 8 | ea |
| | | | | WO-800826 | | | | |
| 01-9 | | | G716-8329519 | TP-VR60 | 8329519 | LOCK, valve spring retainer (exhaust) (used on engines after serial No. 97653) | 8 | ea |
| 01-9 | | | G503-7371238 | WO-643334 | | | | |
| | | | | WO-375994 | 7371238 | LOCK, valve spring retainer, upper (intake)..... | 8 | ea |

| | | | | | | | | |
|-------------|----|---------------|--------------|-----------|---------|--|---|----|
| | | | G758-8329694 | WO-800986 | 8329694 | PACKING, oil valve stem (superseded by PACKING 501220) | 4 | ea |
| 01-9 | H2 | | H002-0501220 | | 501220 | PACKING, "O" ring, class B material, 1/16 thk, 3/8 ID (supersedes PACKING 8329694) | 4 | ea |
| 01-9 | | 2805-737-5034 | G758-8329693 | WO-649751 | 8329693 | RETAINER, intake valve spring | 4 | ea |
| | | | G740-7375034 | EAT-R697 | 7375034 | RETAINER, valve spring, exhaust (used on engines through serial No. 97653) | 4 | ea |
| | | | | WO-800828 | | | | |
| 01-3, 9 | | 5340-360-7925 | G503-7371235 | WO-638636 | 7371235 | SPRING, valve (exhaust) | 4 | ea |
| 01-9 | | | G758-8329695 | WO-800417 | 8329695 | SPRING, valve (intake) | 4 | ea |
| | | 2805-737-5035 | G740-7375035 | EAT-5256 | 7375035 | VALVE, exhaust (used on engines through serial No. 97653) | 4 | ea |
| | | | | WO-800829 | | | | |
| 01-3, 9 | | | G716-8329517 | WO-807342 | 8329517 | VALVE, exhaust (used on engines after serial No. 97653) | 4 | ea |
| 01-9 | | | G758-8329697 | WO-646421 | 8329697 | VALVE, intake | 4 | ea |
| | | | | | | | | |
| | | | | | | 0105.2-PUSH RODS, ROCKER ARMS, TAPPETS, AND COVERS | | |
| 01-9 | | | | WO-805377 | 8677499 | ARM, rocker, left | 2 | ea |
| | | | | WO-805378 | | ARM, rocker, right | 2 | ea |
| 01-4, 9 | | | G758-8329710 | WO-805375 | 8329710 | ARM, rocker, w/BUSHING, left, assy | 2 | ea |
| 01-9 | | | G758-8329711 | WO-805376 | 8329711 | ARM, rocker, w/BUSHING, right, assy | 2 | ea |
| | | | G758-8329712 | WO-805374 | 8329712 | BRACKET, mounting, rocker shaft (superseded by BRACKET WO-802295) | 4 | ea |
| 01-9 | | | | WO-802295 | | BRACKET, mounting, rocker shaft (supersedes BRACKET 8329712) | 4 | ea |
| 01-9 | | 5310-774-4472 | G503-7744472 | WO-641769 | 7744472 | NUT, PLAIN, hex, S, 3/8-24NF-3 | 4 | ea |
| | | | | WO-800200 | | WASHER, flat, sp, 3/8 in. | 4 | ea |
| | | | | WO-806320 | 8677620 | COVER, rocker arm (intake valve spring) | 1 | ea |
| 01-9 | H1 | 012-0368 | H001-4167561 | | 120368 | NUT, PLAIN, hex, s-fin, S, cd- or zn-pltd, 5/16-24NF-2 | 2 | ea |
| 01-9 | | | G758-8329714 | WO-649709 | 8329714 | STUD, hex, spec, S, 5/16-24NF-3 (1/2) 5/16-24NF-3 (1/32) x 2 | 2 | ea |
| 01-9 | H1 | 013-8538 | H001-7021771 | | 138538 | WASHER, lock, int-teeth, S, cd- or zn-pltd, 5/16 in. | 2 | ea |
| 01-1, 3 | | | G758-8329713 | WO-806318 | 8329713 | COVER, rocker arm, assy (intake valve spring) (complete) | 1 | ea |
| 01-15, 03-8 | | | G758-8329715 | WH-210818 | 8329715 | ELBOW, rocker arm cover, 3/8-18NPTF | 1 | ea |
| | | | | WO-806317 | | | | |
| | | | G758-8329716 | WO-648798 | 8329716 | GASKET, rocker cover (intake) 5/16 thk (cork) | 1 | ea |
| 01-9 | | | | WO-648807 | 8679542 | PLUG, rocker arm shaft | 2 | ea |
| | | | G758-8329717 | WO-648791 | 8329717 | ROD, push, valve (superseded by ROD 8330073) | 4 | ea |
| 01-3, 9 | | | G758-8330073 | WO-804622 | 8330073 | ROD, push, valve (supersedes ROD 8329717) | 4 | ea |
| 01-9 | | | G758-8329718 | WO-800173 | 8329718 | SCREW, adjusting, valve clearance | 4 | ea |
| 01-9 | H1 | 012-4920 | H001-4185561 | | 124920 | NUT, jam, hex, lt, s-fin, S, cd- or zn-pltd, 5/16-24NF-2 | 4 | ea |
| 01-9 | | 5305-737-1258 | G503-7371258 | EAT-SL503 | 7371258 | SCREW, adjusting, valve tappet | 4 | ea |
| | | | | WIL-P407A | | | | |
| | | | | WO-640020 | | | | |
| 01-9 | | | | WO-805367 | 8677498 | SHAFT, rocker arm | 1 | ea |
| 01-9 | | | G758-8329719 | WO-648803 | 8329719 | SCREW, hex-hd, spec, 5/16-24NF-2 | 2 | ea |
| 01-4 | | | G758-8329720 | WO-805368 | 8329720 | SHAFT, rocker arm, w/PLUG, assy | 1 | ea |

| (1) ILLUSTRATION NO. | (2) REFER- ENCE SYMBOLS | (3) FEDERAL STOCK NO. | (4) ORDNANCE STOCK NO. | (5) MFR'S PART NO. | (6) ORDNANCE PART NO. | (7) DESCRIPTION | (8) QUANTITY INCOR- PORATED IN UNIT | (9) UNIT OF ISSUE |
|---|----------------------------------|-----------------------------|------------------------------|--|-----------------------------|--|---|----------------------------|
| GROUP 01—ENGINE—Continued | | | | | | | | |
| 0105.2—PUSH RODS, ROCKER ARMS, TAPPETS, AND COVERS—Continued | | | | | | | | |
| 01-3, 9 | | | G758-8329721 | WO-649666 CCS-65C634 | 8329721 8677296 | SPRING, rocker shaft..... | 2 | ea |
| | | | | WO-647071 | | TAPPET, valve (optional w/TAPPET 7372585)..... | 4 | ea |
| 01-9 | | 2805-737-2585 | G740-7372585 | WIL-MT9281 WO-647072 | 7372585 | TAPPET, valve (optional w/TAPPET 8677296)..... | 4 | ea |
| 01-9 | | | G758-8330225 | EAT-MT9666 WO-800589 CCS-65C679 WO-800550 | 8330225 | TAPPET, valve (intake)..... | 4 | ea |
| | | 2805-774-3569 | G503-7743569 G758-8329984 | WO-115948 WO-674993 | 7743569 8329984 | TAPPET, valve, 0.004 oversize..... | 4 | ea |
| | | | | | | WASHER, spring, S, cd- or zn-pltd, $2\frac{1}{64}$ ID, $\frac{5}{8}$ OD (rocker arm cover hold-down nut) | 2 | ea |
| 0105.3—CAMSHAFT | | | | | | | | |
| 01-9 | | 2805-774-4319 | G503-7744319 | WO-645595 | 7744319 | BEARING, bushing type, 2.188 ID (front)..... | 1 | ea |
| 01-3, 9 | | | G758-8329698 | WO-800517 | 8329698 | CAMSHAFT..... | 1 | ea |
| 01-9 | | 2805-735-1413 | G740-7351413 | WO-802576 | 7351413 | PLATE, thrust..... | 1 | ea |
| 01-9 | H1 | 042-3569 | H101-0423569 | | 423569 | SCREW, INTEGRAL LOCK WASHER, ext-teeth, hex-hd, S, cd- or zn-pltd, $\frac{3}{8}$ -16NC-2 x $\frac{3}{4}$ (plate to block) | 2 | ea |
| | | | | WO-907879 | | PLUG, expansion, S, $1\frac{3}{4}$ dia (cylinder block camshaft rear end pilot) | 1 | ea |
| 01-9 | | 774-1407 | G503-7741407 | WO-641049 | 7741407 | SPACER, thrust plate..... | 1 | ea |
| 0105.5—CAMSHAFT DRIVE AND TIMING GEAR COVER | | | | | | | | |
| 01-3, 7 | | 2805-737-2576 | G740-7372576 | WO-643834 | 7372576 | COVER, timing gear..... | 1 | ea |
| 01-7 | H1 | | H101-0423569 | | 423569 | BOLT, INTEGRAL LOCK WASHER, ext-teeth, hex- hd, S, cd- or zn-pltd, $\frac{3}{8}$ -16NC-3 x $\frac{3}{4}$ (supersedes (6) NUT 271193 and (6) STUD 103195) | 6 | ea |
| 01-7 | H1 | | H101-0271193 | | 271193 | NUT, hex, lt, ext-teeth-lock washer, S, cd- or zn-pltd, $\frac{3}{8}$ -24NF-2B (use up to engine serial No. 83476) (superseded by (6) BOLT 423569) | 10 | ea |
| 01-7 | H1 | 012-3520 | H001-5421221 | | 123520 | SCREW, cap, hex-hd, S, cd- or zn-pltd, $\frac{3}{8}$ -24NF-3 x $\frac{3}{4}$ | 3 | ea |
| 01-7 | H1 | | H001-5421261 | | 120647 | SCREW, cap, hex-hd, S, cd- or zn-pltd, $\frac{3}{8}$ -24NF-3 x 1 | 1 | ea |

| | | | | | | | | | |
|--------------------------|----|---------------|--------------|--|---------|--|---|----|--|
| | H1 | | H001-1312500 | | 103195 | STUD, S, $\frac{3}{8}$ -16NC ($\frac{5}{16}$) x $\frac{3}{8}$ -24NF-2 ($\frac{5}{8}$) x $1\frac{1}{16}$ (gear cover) (superseded by BOLT 423569) | 6 | ea | |
| 01-7 | | 2805-774-1427 | G503-7741427 | WO-641096 | 7741427 | GASKET, front plate to cylinder block | 1 | ea | |
| 01-7 | | 2805-360-7941 | G503-7371159 | WO-630365 | 7371159 | GASKET, timing gear cover | 1 | ea | |
| 01-6, 9 | | 2805-774-1415 | G503-7741415 | WO-641282 | 7741415 | GEAR, drive, camshaft (28T) | 1 | ea | |
| 01-6 | H1 | | H101-0124552 | | 124552 | KEY, Woodruff, alloy-S, $\frac{3}{16}$ x 1 (No. 608 or 13) | 1 | ea | |
| 01-9 | | 2805-774-1419 | G503-7741419 | WO-641283 | 7741419 | GEAR, driven, camshaft (56T) | 1 | ea | |
| 01-9 | H1 | 012-2260 | H001-5421941 | | 122260 | BOLT, cap, hex-hd, S, cd- or zn-pltd, $\frac{1}{16}$ -14NC-3 x $1\frac{1}{8}$ | 1 | ea | |
| 01-9 | H1 | 012-4549 | H001-0518022 | | 124549 | KEY, Woodruff, alloy-S, $\frac{3}{16}$ x $\frac{3}{4}$ (No. 606 or 9) | 1 | ea | |
| 01-9 | | 2805-774-1406 | G503-7741406 | WO-642520 | 7741406 | WASHER, flat, $1\frac{1}{32}$ ID, $1\frac{1}{2}$ OD, $\frac{5}{32}$ thk | 1 | ea | |
| 01-9 | H1 | 5310-013-6857 | H001-7017711 | | 136857 | WASHER, lock, ext-teeth, S, cd- or zn-pltd, $\frac{1}{16}$ in. | 1 | ea | |
| 01-3, 7 | | 2805-737-2578 | G740-7372578 | WO-649823 | 7372578 | PLATE, engine mounting, front | 1 | ea | |
| 01-7 | H1 | 042-3569 | H101-0423569 | | 423569 | BOLT, INTEGRAL, LOCK WASHER, ext-teeth, hex-hd, S, cd- or zn-pltd, $\frac{3}{8}$ -16NF-3 x $\frac{3}{4}$ | 3 | ea | |
| | | 5340-495-9547 | G740-7372579 | WO-375917 | 7372579 | RING, retaining, timing gear cover packing | 1 | ea | |
| 01-6 | | 2805-774-1414 | G503-7741414 | WO-641281 | 7741414 | SPACER, camshaft, drive gear | 1 | ea | |
| 0106.1 - OIL PUMP | | | | | | | | | |
| | | 3120-774-4331 | G503-7744331 | WIL-ER90139 $\frac{3}{4}$ WO-645629 | 7744331 | BEARING, bushing type (shaft) | 1 | ea | |
| 01-10 | | | | EAT-ER3675 WO-804486 | | BODY, oil pump | 1 | ea | |
| 01-10 | | 2805-774-4332 | G503-7744332 | EAT-ER5362 WO-641479 | 7744332 | COVER, body | 1 | ea | |
| 01-10 | H1 | | H001-5451601 | | 180018 | BOLT, MACHINE, lock washer, cap, hex-hd, S, $\frac{1}{4}$ -20NC-2 x $\frac{5}{8}$ | 3 | ea | |
| 01-10 | | 2805-774-4324 | G503-7744324 | EAT-ER8145 WO-641482 | 7744324 | GASKET, cover | 1 | ea | |
| 01-10 | | 2805-360-7950 | G740-7372587 | WO-646147 | 7372587 | GASKET, pump to cylinder block | 1 | ea | |
| 01-10 | | | G503-7371270 | MDR-507 WO-634813 | 7371270 | GASKET, relief plunger spring retainer | 1 | ea | |
| 01-10 | | 2805-774-4333 | G503-7744333 | EAT-ER90358 WO-641047 | 7744333 | GEAR, driven (12T) | 1 | ea | |
| 01-10 | H1 | | H101-0141138 | | 141138 | PIN, dowel, S, $\frac{5}{32}$ x $\frac{31}{32}$ (supersedes PIN 7371279) | 1 | ea | |
| 01-10 | | | | EAT-ER90419 $1\frac{1}{16}$ WO-642214 | | PIN, drive, 0.1875 x $1\frac{1}{16}$ (inner rotor to shaft) | 1 | ea | |
| | | | G503-7371279 | EAT-ER90359 WO-330964 | 7371279 | PIN, S, $\frac{5}{32}$ x $\frac{31}{32}$ (superseded by PIN 141138) | 1 | ea | |
| 01-1, 4, 10 | | 2805-737-6907 | G740-7376907 | EAT-ER10317 EAT-10317 WO-804484 | 7376907 | PUMP, oil, complete, assy | 1 | ea | |
| | H1 | | H101-9409118 | | 9409118 | BOLT, MACHINE, assembled washer, hex-hd, split lock washer, S, cd- or zn-pltd, $\frac{5}{16}$ -18UNC-2A x $2\frac{1}{2}$ | 2 | ea | |
| | H1 | | | | 431938 | SCREW, INTEGRAL, LOCK WASHER, hex-hd, S, cd- or zn-pltd, $\frac{5}{16}$ -18NC-3 x 1 | 1 | ea | |

| (1) ILLUSTRATION NO. | (2) REFER- ENCE SYMBOLS | (3) FEDERAL STOCK NO. | (4) ORDNANCE STOCK NO. | (5) MFR'S PART NO. | (6) ORDNANCE PART NO. | (7) DESCRIPTION | (8) QUANTITY INCOR- PORATED IN UNIT | (9) UNIT OF ISSUE |
|----------------------------------|----------------------------------|-----------------------------|------------------------------|--------------------------------------|-----------------------------|--|---|----------------------------|
| GROUP 01—ENGINE—Continued | | | | | | | | |
| 0106.1—OIL PUMP—Continued | | | | | | | | |
| 01-4, 10 | | | G503-7371271 | WIL-ER7154 WO-630390 | 7371271 | RETAINER, relief plunger spring..... | 1 | ea |
| 01-10 | | | | EAT-ER4642J WO-641484 | | ROTOR, inner..... | 1 | ea |
| 01-10 | | | | EAT-ER4425J WO-641483 | 8673952 | ROTOR, outer..... | 1 | ea |
| 01-10 | | | | EAT-ER6303 WO-641480 | | SHAFT..... | 1 | ea |
| 01-4 | | 2805-360-4524 | G503-7371268 G740-7372586 | EAT-ER2413 WO-641742 | 8673956 | SHAFT, w/ROTOR, assy..... | 1 | ea |
| 01-4, 10 | | | G758-8331246 | WO-630389 WIL-ER7196 WO-645628 | 7371268 7372586 | SHIM, relief plunger spring..... | 1 | ea |
| 01-4, 10 | | 3120-360-4522 | G503-7371275 | EAT-ER7200 WO-630518 | 7371275 | SPRING, relief plunger (superseded by SPRING 8331246) | 1 | ea |
| | | | | WO-808385 | 8331246 | SPRING, relief plunger (supersedes SPRING 7372586)..... | 1 | ea |
| | | | | | | VALVE, relief..... | 1 | ea |
| 0106.2—OIL FILTER | | | | | | | | |
| 01-12 | | | | FR-5310-2 WO A15441 WO-A3150 | | BODY, oil filter (used w/FILTER 540501)..... | 1 | ea |
| | | | | CU-28751U WO-120640 | | BOLT, welding, S, cd-pltd or tnd, $\frac{5}{16}$ -24NF x $\frac{3}{4}$ (filter support bracket to dash panel) | 1 | ea |
| 01-13 | H1 | 5310-012-0372 | H001-4029501 | | 120372 | BRACKET, mounting, includes NUTS and SCREWS, assy (oil filter to mounting bracket on cylinder head) | 1 | ea |
| 01-13 | H1 | | H001-5128691 | | 132277 | NUT, sq, reg, unfin, S, cd- or zn-pltd, $\frac{1}{4}$ -20NC-2..... | 1 | ea |
| | | | G758-8328422 | WO-805815 | 8328422 | SCREW, mach, fil-hd, S, cd- or zn-pltd, $\frac{1}{4}$ -20NC-2 x $1\frac{1}{4}$ | 1 | ea |
| | H1 | | H101-0271187 | | 271187 | BRACKET, mounting, oil filter cylinder head (used on vehicles through serial No. 28132) | 1 | ea |
| | H1 | 012-0741 | H001-5419821 | | 120741 | NUT, hex, lt, ext-teeth, lock washer, S, cd- or zn-pltd, $\frac{5}{16}$ -24NF-2B | 2 | ea |
| 01-13 | | | G740-7369881 | CU-28717 WO-802496 | 7369881 | SCREW, cap, hex-hd, S, cd- or zn-pltd, $\frac{5}{16}$ -24NF-3 x $\frac{3}{4}$ | 2 | ea |
| | | | G758-8330271 | WO-802087 | 8330271 | BRACKET, mounting (oil filter to mounting bracket on cylinder head) | 1 | ea |
| | H1 | 012-0213 | H001-5419841 | | 120213 | BRACKET, support, oil filter, assy (used on vehicles after serial No. 28132) | 1 | ea |
| | | | | | | BOLT, mach, cap, hex-hd, S, cd- or zn-pltd, $\frac{5}{16}$ -24NF-3 x $\frac{7}{8}$ | 3 | ea |

| | | | | | | | | |
|----------|-----|---------------|--------------|---|--------------------|---|---|----|
| | H1 | | H101-0271187 | | 271187 | NUT, hex, lt, ext-teeth lock washer, S, cd- or zn-pltd, $\frac{5}{16}$ -24NF-2B | 4 | ea |
| | H1 | | | | 431938 | SCREW, INTEGRAL, LOCKWASHER, hex-hd, S, cd- or zn-pltd, $\frac{5}{16}$ -18NC-3 x 1 | 1 | ea |
| 01-12 | | | | FR-102153 WO-119987 | | CLAMP, engine oil filter body (used w/FILTER 540501) | 2 | ea |
| 01-12 | | | G509-7529093 | FR-11559 WO-119986 | 7529093 | COVER, oil filter (used w/FILTER 540501) | 1 | ea |
| | | | G507-6245928 | FR-5241 WO-A15438 FR-A15540 | 6245928 | COVER, w/SCREW, WASHER, locking SPRING and GASKET, assy (used w/FILTER 540501) | 1 | ea |
| 01-12 | H16 | | H016-0540462 | | 540462 | ELEMENT, oil filter (used w/FILTER 540501) | 1 | ea |
| | | | | | | ELEMENT, assy (used w/FILTER 540501) | 1 | ea |
| | | | | FR-A15540 WO-119953 CU-12567 WO-801933 | 7039934 7375060 | Composed of: 1 ELEMENT 1 GASKET | | |
| | | 2940-737-5060 | G740-7375060 | | 7375060 | FILTER, oil, assy (superseded by FILTER 540501) (used on vehicles through serial No. 28132) | 1 | ea |
| 01-2, 12 | H16 | | H016-0540501 | | 540501 | FILTER, oil, assy (supersedes FILTER 7375060) (used on vehicles after serial No. 28132) | 1 | ea |
| 01-12 | H1 | | H001-4139781 | | 120399 | NUT, mach screw, sq, S, cd- or zn-pltd, $\frac{5}{16}$ -18NC-2 | 2 | ea |
| 01-12 | H1 | 5305-013-3129 | H001-5150831 | | 133129 | SCREW, mach, rd-hd, S, cd-orzn-pltd, $\frac{5}{16}$ -18NC-2 x 2 $\frac{1}{2}$ | 2 | ea |
| 01-12 | H1 | 5310-011-6120 | H101-0116120 | | 116120 | WASHER, lock, med, S, phos-ctd, $\frac{5}{16}$ in. | 2 | ea |
| 01-12 | | | G509-5308281 | FR-11581 WO-119982 | A308281 | GASKET, cover bolt, cop, 0.750 OD, 0.540 ID, 0.062 thk (used w/FILTER 540501) | 1 | ea |
| 01-12 | | | G749-7039934 | FR-11582 WO-119953 | 7039934 | GASKET, cover, ru, 5.125 OD, 4.375 ID, 0.058 thk (used w/FILTER 540501) | 1 | ea |
| 01-13 | | | G740-7375059 | CU-28649 WO-118291 | 7375059 | GASKET, head (used w/FILTER 7375060) | 1 | ea |
| 01-12 | | | | FR-100918 | | GROMMET, oil filter element (used w/FILTER 540501) | 1 | ea |
| 01-13 | | 2940-737-5058 | G740-7375058 | CU-12567-2 WO-118288 | 7375058 | HEAD, w/CARTRIDGE, assy (used w/FILTER 7375060) | 1 | ea |
| 01-13 | | | | CU-F762 WO-118293 | | NUT, hex, No. 12-24NC | 6 | ea |
| 01-13 | | | | CU-F761 WO-118292 | | SCREW, fil-hd, No. 12-24NC x $\frac{3}{4}$ | 6 | ea |
| | H6 | 012-7951 | H006-0283195 | | 127951 | PLUG, pipe, hex-hd, br, $\frac{1}{4}$ in. (engine oil filter drain) (used w/FILTER 540501) | 1 | ea |
| 01-13 | H6 | | H006-0283205 | | 112578 | PLUG, pipe, sq-hd, br, $\frac{1}{4}$ in. (engine oil filter drain) (used w/FILTER 7375060) | 1 | ea |
| 01-13 | | 2940-737-5057 | G740-7375057 | CU-28648 WO-118290 | 7375057 | RING, reinforcing (used w/FILTER 7375060) | 1 | ea |
| 01-12 | | | G179-5308280 | FR-11580 WO-119985 | 5308280 | SCREW, cap, hex-hd, S, oil filter cover $\frac{7}{16}$ -20NF-1 x 1 $\frac{11}{16}$ (cover attaching) (used w/FILTER 540501) | 1 | ea |
| 01-12 | | | G509-0389511 | FR-11583 WO-119983 | A308282 | SPRING, tension, locking, cover bolt (used w/FILTER 540501) | 1 | ea |
| 01-13 | | 2940-737-5056 | G740-7375056 | CU-28651U WO-118289 | 7375056 | SUMP, oil filter (used w/FILTER 7375060) | 1 | ea |

0106.5

52

| (1) ILLUSTRATION NO. | (2) REFER- ENCE SYMBOLS | (3) FEDERAL STOCK NO. | (4) ORDNANCE STOCK NO. | (5) MFR'S PART NO. | (6) ORDNANCE PART NO. | (7) DESCRIPTION | (8) QUANTITY INCOR- PORATED IN UNIT | (9) UNIT OF ISSUE |
|--|----------------------------------|-----------------------------|------------------------------|---------------------------|-----------------------------|---|---|----------------------------|
| GROUP 01—ENGINE—Continued | | | | | | | | |
| 0106.5—CRANKCASE VENTILATOR | | | | | | | | |
| | | | G503-7368267 H006-8330945 | WO-A5105 | 7368267 8330945 | BRACKET, support, oil filler pipe..... | 1 | ea |
| | H6 | | | | | CLAMP, hose (Tinnerman), S, phos-ctd, 1 ³ / ₁₆ ID (valve to reducer hose) (used on vehicles after serial No. 23359) | 2 | ea |
| | H6 | | H006-0214317 | | 137406 | CONNECTOR, flared tube inverted, br, 5 ¹ / ₁₆ tube, 1 ¹ / ₈ male pipe end (w/o NUT) (vent tube to manifold tee) | 1 | ea |
| 01-16 | | | | WO-809656 | | ELBOW, pipe, automotive, street, 90 deg, S, zn-pltd, 1 ¹ / ₈ in. (vent body to nipple) | 2 | ea |
| 01-16 | | | G503-7371272 G758-8332085 | WO-630299 WO-809084 | 7371272 8332085 | GASKET, crankcase ventilator to valve spring cover..... | 1 | ea |
| | | | | | | HOSE, check valve to reducer, 1 ¹ / ₂ ID, 0.082 OD, 2 lg (superseded by HOSE 839875) (used on vehicles after serial No. 23359) | 1 | ea |
| | H7 | | H007-0839875 | | 839875 | HOSE, check valve to reducer, 1 ¹ / ₂ ID (supersedes HOSE 8332085) | † | ft |
| 01-4, 15 | | | G758-8329683 H106-0143932 | WO-807386 | 8329683 143932 | PIPE, oil filler, assy..... | 1 | ea |
| | H6 | 014-3932 | | | | PLUG, pipe, sq-hd, CI, cd- or zn-pltd, 1 ¹ / ₈ in. (vacuum tube tee) | 1 | ea |
| | | 4730-737-6248 | G758-8329684 G136-7376248 | WO-649052 WH-103-60002 | 8329684 7376248 | SPACER, oil filler pipe bracket..... | 1 | ea |
| 03-8 | | 2910-741-0836 | G740-7410836 | WO-807713 ANB-SK971 | | TEE, pipe, stght, extruded, br, or S, cd- or zn-pltd, 1 ¹ / ₂ -27NPTF (vacuum tube to manifold) | 1 | ea |
| 01-4, 16; 03-8 | | 2805-360-7864 | G503-7371286 | WO-804277 WO-A6919 | 7410836 7371286 | VALVE, w/PIN, assy (shut-off, w/control WIRE)..... | 1 | ea |
| | | | | | | VENTILATOR, crankcase, assy..... | 1 | ea |
| 0106.6—OIL LINES, LEVEL GAGE, AND OIL PAN | | | | | | | | |
| | | | G758-8328405 H101-9409106 | WO-800549 | 8328405 9409106 | BRACKET, crankcase oil line clip..... | 1 | ea |
| | H1 | | | | | BOLT, MACHINE, assembled washer, hex-hd, split lockwasher, S, cd- or zn-pltd, 1 ¹ / ₄ -20UNC-2 x 1 ¹ / ₂ | 1 | ea |
| | H4 | | H104-0432666 | | 432666 | CLIP, phos-ctd, 3 ¹ / ₁₆ tube (type E) (supersedes CLIP 7372832) (oil line to cylinder head) | 1 | ea |
| | | 5340-737-2832 | G740-7372832 | WO-645539 | 7372832 | CLIP, (type E) phos-ctd, 3 ¹ / ₁₆ tube (oil line to cylinder head) (superseded by CLIP 432666) | 1 | ea |
| | H4 | | H104-0107839 | | 107839 | CLIP, closed, S, cd- or zn-pltd, 3 ¹ / ₁₆ OD tube, hole for 3 ¹ / ₈ bolt (oil inlet hose to engine plate (1), to water pump mtg bolt (1)) (used w/LINE 8328409) | 2 | ea |
| | H4 | | H004-0327791 | | 128302 | CLIP, closed, S, cd- or zn-pltd, 1 ¹ / ₂ OD tube, hole for 3 ¹ / ₈ bolt (oil inlet hose to engine plate (1), to water pump mtg bolt (1)) (used w/LINE 8331932) | 2 | ea |

| | | | | | | | | |
|-------------|----|---------------|--------------|-----------|------------|--|----|----|
| 01-5 | H6 | | H005-0214310 | | 137404 | CONNECTOR, flared tube, inverted, br, $\frac{3}{16}$ in tube, $\frac{1}{8}$ male pipe end (w/o NUT) (oil line to cylinder head) (optional w/CONNECTOR 148072) | 1 | ea |
| | H6 | | H006-0214315 | | 137405 | CONNECTOR, flared tube, inverted, br, ($\frac{1}{4}$ tube, $\frac{1}{8}$ male pipe end w/o NUT) (oil filter inlet line) | 1 | ea |
| | H6 | | H006-0214522 | | 148072 | CONNECTOR, flared tube, inverted, S, cd- or zn-pltd, $\frac{3}{16}$ tube, $\frac{1}{8}$ male pipe end (w/o NUT) (oil line to cylinder head) (optional w/CONNECTOR 137404) | 1 | ea |
| | H6 | | H006-0260846 | | 137420 | ELBOW, flared tube, inverted, 90 deg, br, $\frac{3}{16}$ tube, $\frac{1}{8}$ male pipe end (w/o NUT) (oil line to cylinder block) | 1 | ea |
| | H6 | | H006-0260807 | | 137421 | ELBOW, flared tube, inverted, 90 deg, br, $\frac{1}{4}$ tube, $\frac{1}{8}$ male pipe end (oil filter outlet) (used w/FILTER 540501) | 1 | ea |
| | H6 | 044-4038 | H106-0444038 | | 444038 | ELBOW, pipe, automotive, street, 90 deg, extruded, br, $\frac{1}{8}$ in (oil filter inlet line to cylinder block) (used on FILTER 7375060 outlet elbow M38A1 up to serial No. 28132 (2), used on M170 (1)) | 2 | ea |
| | | | | | | M38A1 | 1 | ea |
| | | | | | | M170 | 1 | ea |
| 01-7 | | 4730-737-2557 | G740-7372557 | WO-641050 | 7372557 | FITTING, oil, timing gear | 1 | ea |
| 01-15 | | | G758-8328406 | WO-807392 | 8328406 | GAGE, bayonet type, oil level, w/CAP | 1 | ea |
| 01-11 | | | G503-7371283 | WO-639980 | 7371283 | GASKET, oil pan | 1 | ea |
| 01-11 | | 5330-737-6904 | G740-7376904 | WO-806515 | 7376904 | GASKET, oil pan drain plug | 1 | ea |
| 01-11 | | | G503-7371267 | WO-630398 | 7371267 | GASKET, oil strainer support | 1 | ea |
| | | | G758-8328408 | WO-648865 | 8328408 | LINE, crankcase to cylinder head, assy | 1 | ea |
| | | | | | 137396 | Composed of: | | |
| | | | | | 44-T-5080- | 2 NUT | | |
| | | | | | 10 | 1 TUBE (19 $\frac{3}{8}$ in lg) | | |
| | | | G758-8331932 | WO-808359 | 8331932 | LINE, flexible, oil filter inlet, assy (used w/FILTER 540501) | 1 | ea |
| | | | G758-8328409 | WO-807390 | 8328409 | LINE, flexible, oil filter inlet, assy (used on vehicles serial No. 28132) (used w/FILTER 7375060) | 1 | ea |
| | | | G758-8328410 | WO-805816 | 8328410 | LINE, flexible, oil filter outlet, 14 $\frac{1}{2}$ in lg (used on vehicles through serial No. 28132) (used w/FILTER 7375060) | 1 | ea |
| | | | G758-8330272 | WO-807706 | 8330272 | LINE, flexible, oil filter outlet, 11 in lg (used on vehicles serial No. 28132) (used w/FILTER 540501) | 1 | ea |
| | | | G758-8332530 | WO-809916 | 8332530 | LINE, flexible, oil filter outlet, 11 in lg (supersedes LINE 8330272) (used w/FILTER 540501 after serial No. 28132) | 1 | ea |
| | | | G758-8328407 | WO-806991 | 8328407 | LINE, oil, sending unit, assy | 1 | ea |
| | | | | WO-A7239 | | PAN, oil | 1 | ea |
| 01-1, 4, 11 | | | G503-7371278 | WO-A7238 | 7371278 | PAN, oil, assy | 1 | ea |
| 01-11 | H1 | 018-7527 | H101-0187527 | | 187527 | BOLT, hex-hd, ext-teeth lock washer, S, cd- or zn-pltd, $\frac{5}{16}$ -18NC-2 x $\frac{5}{8}$ | 14 | ea |

| (1) ILLUSTRATION NO. | (2) REFERENCE SYMBOLS | (3) FEDERAL STOCK NO. | (4) ORDNANCE STOCK NO. | (5) MFR'S PART NO. | (6) ORDNANCE PART NO. | (7) DESCRIPTION | (8) QUANTITY INCORPORATED IN UNIT | (9) UNIT OF ISSUE |
|--|--------------------------|--------------------------|---------------------------|-------------------------|--------------------------|---|--------------------------------------|----------------------|
| GROUP 01—ENGINE—Continued | | | | | | | | |
| 0106.6—OIL LINES, LEVEL GAGE, AND OIL PAN—Continued | | | | | | | | |
| 01-4, 11 | | | G503-7388074 | FM-GPW6727 WO-639979 | 7388074 | PLUG, oil drain, S, 7/8 in (oil pan) (superseded by PLUG 7351892) | | |
| | | | G758-7351892 | WO-809517 | 7351892 | PLUG, oil drain, sq-socket-hex-hd, (ck) S, 7/8-18NS-3 (supersedes PLUG 7388074) | 1 | ea |
| 01-3, 4, 11 | | | G503-7036578 | WO-630396 | 7036578 | STRAINER, oil, floating, engine, assy. | 1 | ea |
| 01-11 | H1 | 012-0123 | H001-4417741 | | 120123 | PIN, cotter, split, S, cd- or zn-pltd, 1/8 x 1 1/4 | 1 | ea |
| 01-4, 11 | | | G503-7371264 | WO-630397 | 7371264 | SUPPORT, floating oil strainer | 1 | ea |
| 01-11 | H1 | | H101-0451975 | | 451975 | SCREW, lock washer, sltd-hex-hd, S, cd- or zn-pltd, 5/16-18NC-3 x 3/4 | 2 | ea |
| | H7 | | H007-0218040 | | 44-T-5080-10 | TUBING, cop, seamless, soft annealed, size 3/8 in, 0.250 OD, 0.035 thk of wall | 1 | ft |
| 0108—EXHAUST MANIFOLD | | | | | | | | |
| 01-14 | | | G758-8329751 | WO-648935 | 8329751 | GASKET (center) | 1 | ea |
| 01-14 | | | G758-8329750 | WO-648795 | 8329750 | GASKET (end) | 2 | ea |
| 01-14 | | | | WO-648886 | 8677644 | MANIFOLD | 1 | ea |
| | | | G503-7701013 | WO-300143 | 7701013 | STUD, S, 3/8-16NC-3 (5/16) x 3/8-24NF-2 (5/8) x 1 1/2 (superseded by STUD 103196) | 2 | ea |
| 01-1, 4 | | | G758-8329699 | WO-648766 | 8329699 | MANIFOLD, assy | 1 | ea |
| | | | | | 8677644 | Composed of: | | |
| | | | | | 103196 | 1 MANIFOLD | | |
| | | | | | 503354 | 1 STUD | | |
| 01-14 | H1 | 050-3354 | H001-0725270 | | 503354 | NUT, safety, br, 3/8-24NF-3 (critical installations) | 5 | ea |
| | H1 | 5310-012-0394 | H001-7043741 | | 120394 | WASHER, FLAT, S, cd- or zn-pltd, 1 1/2 ID, 1 3/4 OD, 0.065 thk (use on vehicles through engines serial No. 79703) | 1 | ea |
| | H1 | | H101-0539086 | | 539086 | STUD, S, 3/8-16NC (5/16) x 3/8-24NF-2 (5/8) x 1 3/8 (manifold) (superseded by STUD 103196) | 1 | ea |
| 01-14 | H1 | | H001-1312520 | | 103196 | STUD, S, 3/8-16NC (5/16) x 3/8-24NF-2 (5/8) x 1 3/8 (manifold) (supersedes (2) STUD 7701013, (1) STUD 446550 and (1) STUD 539086) | 4 | ea |
| 01-14 | H1 | | H001-1310620 | | 112572 | STUD, S, 3/8-16NC (5/16) x 3/8-24NF-2 (5/8) x 2 3/8 (manifold) | 2 | ea |
| | H1 | | H101-0446550 | | 446550 | STUD, S, 1 1/4 in. (manifold) (superseded by STUD 103196) | 1 | ea |

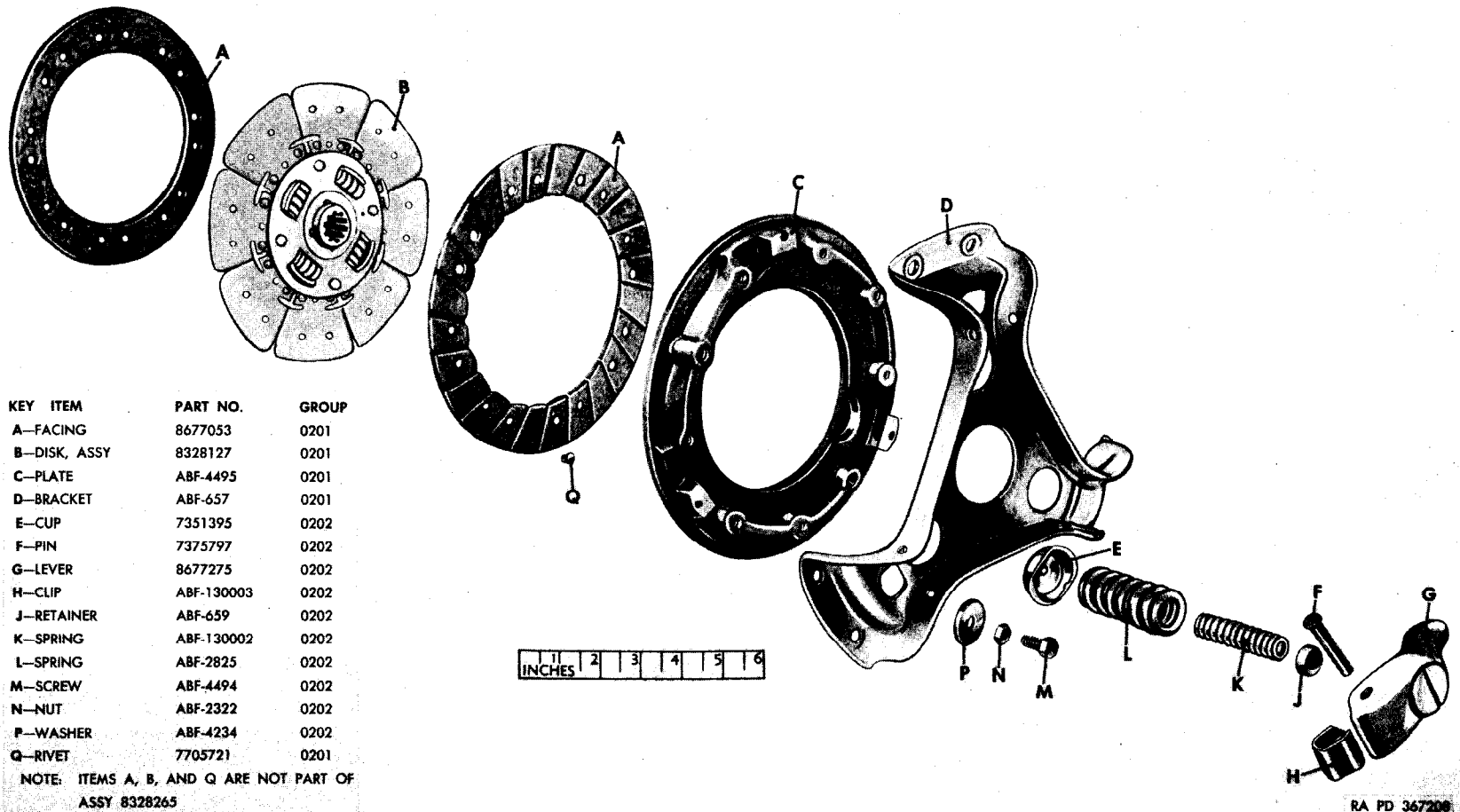
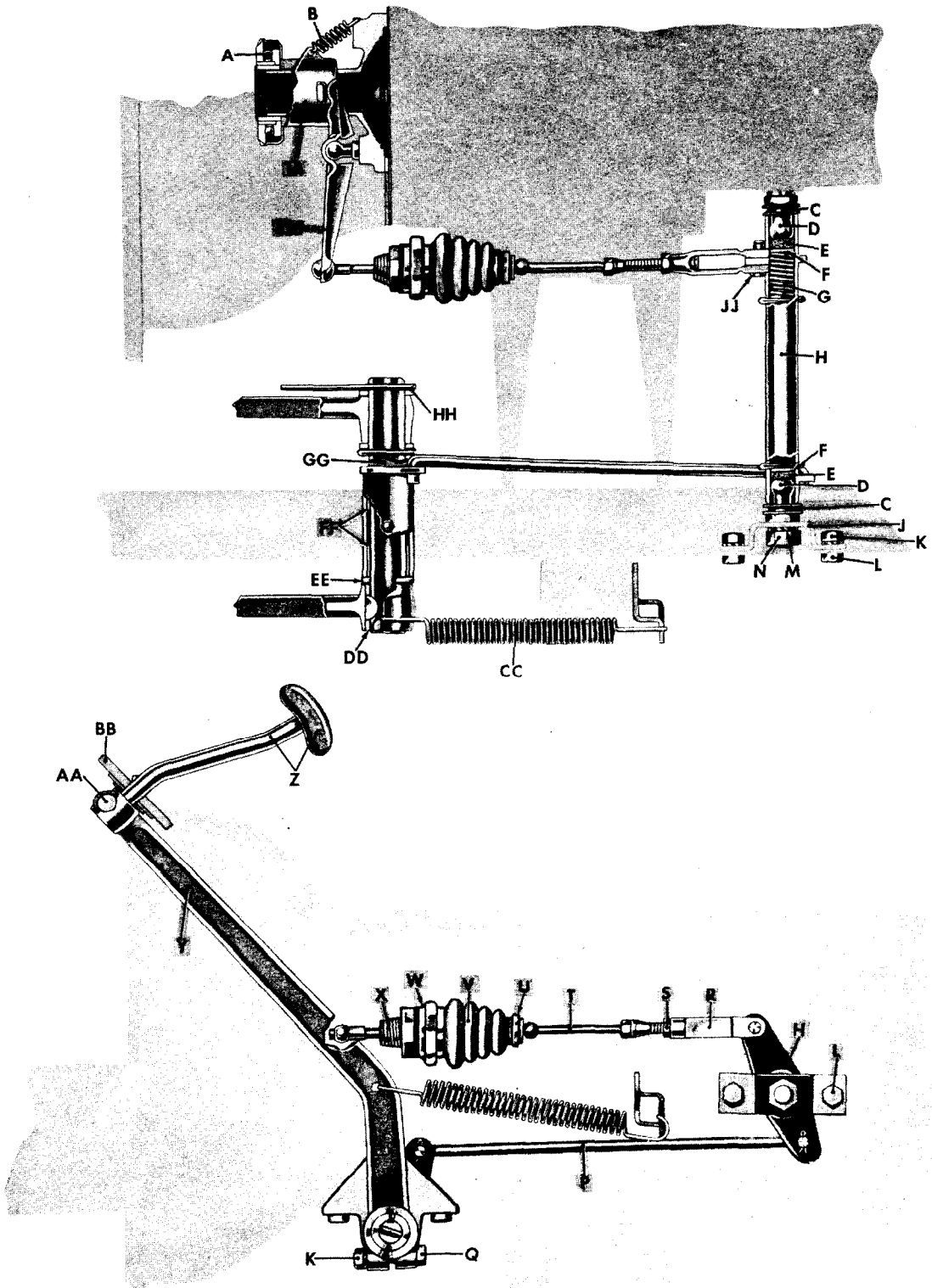

Figure 02-1. Clutch, assy (8328265)—exploded view



RA PD 367167

Figure 02-2. Clutch linkage

| <i>Key</i> | <i>Item</i> | <i>Part No.</i> | <i>Group</i> |
|------------|-------------------|-----------------|--------------|
| A | -BEARING..... | 710203 | 0202 |
| B | -SPRING..... | 7371366 | 0202 |
| C | -SEAL..... | 7371337 | 0202 |
| D | -STUD..... | 5246557 | 0202 |
| E | -PAD..... | 7371364 | 0202 |
| F | -RETAINER..... | 7371340 | 0202 |
| G | -SPRING..... | 5246558 | 0202 |
| H | -LEVER..... | 7372823 | 0202 |
| J | -BRACKET..... | 7368260 | 0202 |
| K | -NUT..... | 271187 | 0202 |
| L | -SCREW..... | 123473 | 0202 |
| M | -WASHER..... | 120383 | 0202 |
| N | -NUT..... | 451403 | 0202 |
| P | -ROD..... | 7372826 | 0202 |
| Q | -SCREW..... | 181618 | 0202 |
| R | -YOKE..... | 7371363 | 0202 |
| S | -NUT..... | 120368 | 0202 |
| T | -CABLE..... | 8328129 | 0202 |
| U | -CLAMP..... | 8328434 | 0202 |
| V | -SEAL..... | 8332072 | 0202 |
| W | -CLAMP..... | 8328435 | 0202 |
| X | -SUPPORT..... | 8328439 | 0202 |
| Y | -PEDAL, ASSY..... | 7371342 | 0202 |
| Z | -PAD, ASSY..... | 8328437 | 0202 |
| AA | -BOLT..... | 9409103 | 0202 |
| BB | -PAD..... | WO-906638 | 0202 |
| CC | -SPRING..... | 8387940 | 0202 |
| DD | -KEY..... | 124549 | 0202 |
| EE | -WASHER..... | 502242 | 0202 |
| FF | -BEARING..... | 7372840 | 1206 |
| GG | -SHAFT..... | 7340237 | 1206 |
| HH | -BAR..... | 8677304 | 1204.1 |
| JJ | -PIN..... | 544190 | 0202 |
| KK | -FORK..... | 7371338 | 0202 |
| LL | -CARRIER..... | 7372822 | 0202 |

Figure 02-2. Clutch linkage—legend

0201

53

| (1) | (2) | (3) | (4) | (5) | (6) | (7) | (8) | (9) |
|-------------------------------------|-------------------|-------------------|------------------------------|-------------------------|-------------------|---|-------------------------------|---------------|
| ILLUSTRATION NO. | REFERENCE SYMBOLS | FEDERAL STOCK NO. | ORDNANCE STOCK NO. | MFR'S PART NO. | ORDNANCE PART NO. | DESCRIPTION | QUANTITY INCORPORATED IN UNIT | UNIT OF ISSUE |
| GROUP 02-CLUTCH | | | | | | | | |
| 0201-DISK AND PRESSURE PLATE | | | | | | | | |
| 02-1 | | | G503-7371368 | WO-639578 ABF-657 | 7371368 | BEARING, bushing type, pilot, clutch..... | 1 | ea |
| | | | | APB-657 WO-640578 | | BRACKET, clutch, pressure plate..... | 1 | ea |
| 02-1 | | | G740-8328127 | WO-804805 | 8328127 | DISK, driven, w/HUB, assy (optional w/DISK ABF-100042, 7372661, and ABF-100021) | 1 | ea |
| | | | | ABF-100042 WO-809228 | | DISK, driven, w/HUB, assy (optional w/DISK 8328127, 7372661, and ABF-100021) | 1 | ea |
| | | 2520-737-2661 | G740-7372661 | B&B-11966 WO-802410 | 7372661 | DISK, driven, cd-pltd, w/HUB, assy (optional w/DISK ABF-100021, 8328127, and ABF-100042) | 1 | ea |
| | | | | ABF-100021 WO-806424 | | DISK, driven, cd-pltd, w/HUB, assy (optional w/DISK 7372661, ABF-100042 and 8328127) | 1 | ea |
| 02-1 | | | | B&B-6170 WO-802411 | 8677053 | FACING, driven disk..... | 2 | ea |
| 02-1 | | 5320-770-5721 | G741-7705721 | B&B-3874 WO-641695 | 7705721 | RIVET, tubular, fl-hd, br, $\frac{3}{64}$ dia, $1\frac{3}{64}$ lg..... | 16 | ea |
| 02-1 | | | | ABF-4495 WO-805017 | | PLATE, pressure..... | 1 | ea |
| | | | G740-8328265 | ABF-100000 WO-804746 | 8328265 | PLATE, pressure, w/BRACKET, assy..... | 1 | ea |
| | H1 | 5310-012-0638 | G503-7324841 H001-7018711 | WO-630129 | 7324841 120638 | SCREW, cap, hex-hd, $\frac{5}{16}$ -18NC-2 x $1\frac{1}{16}$ | 6 | ea |
| | | | | | | WASHER, lock, hv, S, cd- or zn-pltd, $\frac{5}{16}$ in..... | 6 | ea |
| 0202-RELEASE AND CONTROLS | | | | | | | | |
| 02-2 | H12 | | H012-0710203 | | 710203 | BEARING, ball, MIL-STD-CODE 999-13059-0000 (SR, clutch release, 1.5000 bore, 2.8125 OD, 0.6720 overall width) (release) | 1 | ea |
| 02-2 | | 2520-736-8260 | G503-7368260 | WO-A180 | 7368260 | BRACKET (control tube stud) (on frame)..... | 1 | ea |
| 02-2 | H1 | | H101-0271187 | | 271187 | NUT, hex, lt, ext-teeth lock washer, S, cd- or zn-pltd, $\frac{5}{16}$ -24NF-2B | 2 | ea |
| 02-2 | H1 | 012-3473 | H001-5419781 | | 123473 | SCREW, cap, hex-hd, S, cd- or zn-pltd, $\frac{5}{16}$ -24NF-3 x $\frac{5}{8}$ | 2 | ea |
| 02-2 | | | G740-8328129 | TRU-SA4126 WO-805935 | 8328129 | CABLE, control lever, flexible steel..... | 1 | ea |
| | | | | WO-807488 | | CABLE, control, w/SEAL, assy..... | 1 | ea |
| 02-2 | | 2520-737-2822 | G740-7372822 | WO-644366 | 7372822 | CARRIER, release bearing..... | 1 | ea |
| 02-2 | H6 | | H006-8328435 | | 8328435 | CLAMP, hose, S, $1\frac{1}{4}$ OD (control tube lever release cable seal) | 1 | ea |

| | | | | | | | | |
|------------|----|---------------|--------------|-------------------------|---------|--|---|----|
| 02-2 | H6 | | H006-8328434 | | 8328434 | CLAMP, hose, S, phos-ctd, 0.470 in. (ratchet and locking hug ring) (control cable lever release cable seal) | 1 | ea |
| 02-1 | | | | ABF-130003 WO-806012 | | CLIP, pressure spring release lever..... | 3 | ea |
| 02-1 | | 2805-360-8185 | G503-7351395 | ABF-283 WO-638157 | 7351395 | CUP, pressure plate spring..... | 3 | ea |
| 02-2 | | 2520-495-9555 | G503-7371338 | WO-630112 | 7371338 | FORK, release..... | 1 | ea |
| 02-2 | | 2520-737-2823 | G740-7372823 | WO-642624 | 7372823 | LEVER, control, w/TUBE (welded)..... | 1 | ea |
| 02-1 | H1 | 012-0123 | H001-4417741 | | 120123 | PIN, cotter, split, S, cd- or zn-pltd, $\frac{1}{8}$ x $1\frac{1}{4}$ | 2 | ea |
| | | | | ABF-688 WO-640112 | 8677275 | LEVER, release, pressure spring..... | 3 | ea |
| | | | G758-8328436 | WO-807208 | 8328436 | PAD, draft, pedal shank (for service use PAD WO-906638) (used on vehicles through serial No. 74962) | 1 | ea |
| 02-2 | | | | WO-906638 | | PAD, draft, pedal shank (for service only) (used on vehicles after serial No. 74962) | 1 | ea |
| 02-2 | | 5330-737-1364 | G503-7371364 | WO-A176 | 7371364 | PAD, felt, $\frac{5}{8}$ OD, $\frac{1}{4}$ thk (control tube)..... | 2 | ea |
| 02-2 | | | G758-8328437 | WO-807328 | 8328437 | PAD, pedal, assy (welded)..... | 1 | ea |
| 02-2 | H1 | | H101-9409103 | | 9409103 | BOLT, MACHINE, hex-hd, split lock washer, S, cd- or zn-pltd, $\frac{5}{16}$ -18UNC-2A x $1\frac{1}{4}$ | 1 | ea |
| 02-2, 18-6 | | 2540-495-9499 | G503-7371342 | WO-A10269 WO-A405 | 7371342 | PEDAL, assy..... | 1 | ea |
| 02-2 | H1 | 012-4549 | H001-0518022 | | 124549 | KEY, Woodruff, alloy-S, $\frac{3}{16}$ x $\frac{3}{4}$ (No. 606 or 9)..... | 1 | ea |
| 02-2 | H1 | | H101-0271187 | | 271187 | NUT, hex, lt, ext-teeth lock washer, S, cd- or zn-pltd, $\frac{5}{16}$ -24NF-2B | 1 | ea |
| 02-2 | H1 | 018-1618 | H001-5454001 | | 181618 | SCREW, cap, hex-hd, S, 85,000 psi yield strength, cd- or zn-pltd, $\frac{5}{16}$ -24NF-3 x $1\frac{3}{4}$ | 1 | ea |
| 02-1 | | 5305-360-7996 | G503-7375707 | ABF-287 WO-638159 | 7375797 | PIN, pivot, pressure spring release lever..... | 3 | ea |
| 02-1 | | | | ABF-650 WO-804744 | | RETAINER, auxiliary spring..... | 3 | ea |
| 02-2 | | 2520-737-1340 | G503-7371340 | WO-A177 | 7371340 | RETAINER, control tube spring..... | 2 | ea |
| 02-2 | | 2520-737-2826 | G740-7372826 | WO-640123 | 7372826 | ROD, release, pedal..... | 1 | ea |
| 02-1 | H1 | 011-9117 | H101-0119117 | | 119117 | PIN, cotter, split, S, cd- or zn-pltd, $\frac{3}{32}$ x $\frac{1}{2}$ | 2 | ea |
| 02-1 | | | | ABF-4494 WO-805014 | | SCREW, hex-hd, S, 95,000 psi yield strength, 0.312-24NF-3 x $\frac{3}{4}$ (adjusting, pressure spring lever) | 3 | ea |
| 02-1 | | | | ABF-2322 WO-805016 | | NUT, lock, thin, hex-hd, S, 0.312-24NF-2 | 3 | ea |
| 02-1 | | | | ABF-4234 WO-805015 | | WASHER, flat, S, 0.328 ID, 1.125 OD, 0.069 thk..... | 3 | ea |
| 02-2 | | 5330-737-1337 | G503-7371337 | WO-A887 | 7371337 | SEAL, dust, control tube..... | 2 | ea |
| | | | G740-8328130 | WO-804402 | 8328130 | SEAL, release cable (superseded by SEAL 8332072)..... | 1 | ea |
| 02-2 | | | G740-8332072 | WO-808936 | 8332072 | SEAL, release cable (supersedes SEAL 8328130)..... | 1 | ea |
| | | 5340-769-7454 | G740-7697454 | WO-650684 | 7697454 | SPRING, clutch pedal shank draft pad..... | 1 | ea |
| 02-2 | | 524-6558 | G104-5246558 | WO-A178 | 5246558 | SPRING, compression, S, 0.063 dia wire, $\frac{5}{16}$ OD, 8 coils, $1\frac{3}{4}$ free lg (control tube) | 1 | ea |

| (1) ILLUSTRATION NO. | (2) REFER- ENCE SYMBOLS | (3) FEDERAL STOCK NO. | (4) ORDNANCE STOCK NO. | (5) MFR'S PART NO. | (6) ORDNANCE PART NO. | (7) DESCRIPTION | (8) QUANTITY INCOR- PORATED IN UNIT | (9) UNIT OF ISSUE |
|--|----------------------------------|-----------------------------|------------------------------|-------------------------|-----------------------------|---|---|----------------------------|
| GROUP 02-CLUTCH-Continued | | | | | | | | |
| 0202-RELEASE AND CONTROLS-Continued | | | | | | | | |
| 02-1 | | | | ABF-2825 | | SPRING, pressure..... | 3 | ea |
| 02-1 | | | | WO-638156 ABF-130002 | | SPRING, pressure, auxiliary..... | 3 | ea |
| 02-2 | | 2510-368-2630 | G503-7371366 | WO-804745 | 7371366 | SPRING, release bearing carrier..... | 1 | ea |
| 02-2 | | | G503-8387940 | FM-GPW7523 WO-630593 | 8387940 | SPRING, tension, S, 0.0915 dia stk, 0.750 OD, 40 coils, 5 $\frac{3}{4}$ overall lg (pedal retracting) | 1 | ea |
| 02-2 | | 2520-524-6557 | G503-5246557 | WO-A181 | 5246557 | STUD, ball, S, $\frac{7}{16}$ -14NC-2 x 1 $\frac{15}{16}$ overall lg (control tube) | 2 | ea |
| 02-2 | | | | | 451403 | NUT, hex, hv, S, cd- or zn-pltd, $\frac{7}{16}$ -14NC-2..... | 1 | ea |
| 02-2 | H1 | 012-0383 | H001-7025771 | | 120383 | WASHER, lock, med, S, cd- or zn-pltd, $\frac{7}{16}$ in..... | 2 | ea |
| | | 5305-495-9553 | G503-7371339 | WO-A179 | 8393045 | STUD, ball, w/BRACKET, assy..... | 1 | ea |
| 02-2 | | | G758-8328439 | WO-630068 WO-807471 | 7371339 8328439 | STUD, clutch release fork..... SUPPORT, seal, flywheel housing ($\frac{3}{4}$ -14NPTF, SAE short) | 1 1 | ea ea |
| | | 5310-737-5065 | G740-7375065 | WO-A6360 | 7375065 | WASHER, plain, S, $1\frac{1}{32}$ ID, $1\frac{3}{4}$ OD, 0.0747 thk (clutch pedal shank draft pad) (superseded by WASHER 7954265) | 1 | ea |
| | | | | WO-641929 | 7954265 | WASHER, plain, S, cd-pltd, $1\frac{1}{32}$ ID, $1\frac{3}{4}$ OD, 0.0747 thk (clutch pedal shank draft pad) (supersedes WASHER 7375065) | 1 | ea |
| 02-2 | H1 | | H101-0502242 | | 502242 | WASHER, flat, S, $1\frac{1}{32}$ ID, $1\frac{3}{4}$ OD, 0.109 thk (supersedes WASHER 7372827) | 1 | ea |
| | | 5310-456-6298 | G740-7372827 | WO-A498 | 7372827 | WASHER, S, $1\frac{1}{32}$ ID, $1\frac{1}{2}$ OD, $\frac{1}{8}$ thk (pedal shaft) (superseded by WASHER 502242) | 1 | ea |
| 02-2 | | 5340-737-1363 | G503-7371363 | WO-632177 | 7371363 | YOKE, rod end, adjustable (control cable)..... | 1 | ea |
| 02-2 | H1 | 012-0368 | H001-4167561 | | 120368 | NUT, hex, lt, s-fin, S, cd- or zn-pltd, $\frac{5}{16}$ -24NF-2..... | 1 | ea |
| | | 5315-732-6118 | G503-7326118 | WO-339043 | 7326118 | PIN, clevis, S, $\frac{5}{16}$ x $2\frac{7}{32}$ (superseded by PIN 544190)..... | 1 | ea |
| 02-2 | H1 | | H101-0544190 | | 544190 | PIN, clevis, S, $\frac{5}{16}$ x $2\frac{7}{32}$ (supersedes PIN 7326118)..... | 1 | ea |
| | H1 | 011-9117 | H101-0119117 | | 119117 | PIN, cotter, split, S, cd- or zn-pltd, $\frac{3}{32}$ x $\frac{1}{2}$ | 1 | ea |

| Key | Item | Part No. | Key | Item | Part No. |
|-----|------------------------|------------|-----|-----------------------|------------|
| A | -SCREW..... | A293056 | KK | -PLATE, ASSY..... | 8329830 |
| B | -SHAFT, ASSY..... | 8329833 | | 1-PLUG..... | CAR-136-17 |
| C | -WASHER..... | 7372541 | | 2-PLATE..... | CAR-7-177 |
| D | -SEAL..... | 7372530 | | 3-PLATE..... | CAR-148-12 |
| E | -PLUG..... | A312057 | | 4-SPRING..... | CAR-51-21 |
| F | -SEAL..... | 7372529 | | 5-SLEEVE..... | CAR-112-12 |
| G | -WASHER..... | 8329835 | | 6-LOCK..... | CAR-61-79 |
| H | -SPRING..... | CAR-61-426 | LL | -PLUG..... | 7372525 |
| J | -SCREW..... | A346736 | MM | -SCREW..... | A293063 |
| K | -SCREW..... | 7372527 | NN | -PLUG..... | CAR-11B134 |
| L | -HOUSING..... | 7372517 | PP | -STRAINER..... | A293034 |
| M | -SPRING..... | 8329834 | QQ | -GASKET..... | A293030 |
| N | -DIAPHRAGM, ASSY..... | 7372512 | RR | -NUT..... | CAR-15-43 |
| P | -PLUG..... | 7324058 | SS | -CLAMP..... | 8329825 |
| Q | -BODY..... | 7372502 | TT | -GASKET..... | A293029 |
| R | -JET..... | CAR-48-144 | UU | -SEAT..... | CAR-25-149 |
| S | -SCREW W/L WASHER..... | 7372520 | VV | -NEEDLE..... | CAR-17-49 |
| T | -BALL..... | A346738 | WW | -SPRING..... | CAR-61-207 |
| U | -WEIGHT..... | 7372542 | XX | -PIN..... | 7378099 |
| V | -GASKET..... | 7372514 | YY | -TUBE..... | 7372536 |
| W | -SCREW..... | 131958 | ZZ | -TUBE, ASSY..... | 7372537 |
| X | -SHAFT, ASSY..... | 7372531 | AB | -AXLE..... | 7372500 |
| Y | -SPRING..... | 7372533 | AC | -FLOAT, ASSY..... | 7372513 |
| Z | -JET..... | CAR-145-69 | AD | -JET..... | 7372519 |
| AA | -PLUG..... | 7324060 | AE | -ROD, ASSY..... | 8329832 |
| BB | -SCREW..... | 7343368 | AF | -PIN..... | 7372522 |
| CC | -NUT..... | 120619 | AG | -DIAPHRAGM, ASSY..... | 7372511 |
| DD | -BRACKET, ASSY..... | 8329773 | AH | -SPRING..... | 7372534 |
| EE | -SCREW..... | 120221 | AJ | -HOUSING..... | 7372518 |
| FF | -WASHER..... | 7372539 | AK | -BALL, ASSY..... | 7412959 |
| GG | -SEAL..... | 7372528 | AL | -STRAINER..... | A281437 |
| HH | -BODY..... | CAR-6-802 | AM | -GASKET..... | 7378054 |
| JJ | -SCREW..... | A281457 | AN | -PLUG..... | CAR-11B124 |
| | | | AP | -GASKET..... | 8329826 |
| | | | AQ | -PLUG..... | CAR-47-23 |
| | | | AR | -BODY..... | CAR-1-897 |
| | | | AS | -PLUG..... | A281413 |
| | | | AT | -PLATE..... | 8329831 |
| | | | AU | -SCREW..... | A346734 |

Note: All parts listed are in group 0301.

Figure 03-1. Carburetor assy (8329774)—exploded view—legend

| KEY ITEM | PART NO. | GROUP |
|--|------------|--------|
| A—SCREW | AC-456409 | 0302.1 |
| B—GASKET | 8329702 | 0302.1 |
| C—VACUUM SECTION—SEE FIG 03-5 | | |
| D—SPRING | AC-5590533 | 0302.1 |
| E—RETAINER | A-214761 | 0302.1 |
| F—DIAPHRAGM | AC-5593181 | 0302.1 |
| G—BODY, ASSY, FUEL AND VACUUM SECTION—SEE FIG 03-4 | | |
| H—SPRING | A-323138 | 0302.1 |
| J—CAP | A-214746 | 0302.1 |
| K—DIAPHRAGM | 8332534 | 0302.1 |
| L—FUEL SECTION—SEE FIG 03-3 | | |
| M—WASHER | 120217 | 0302.1 |
| N—SCREW | 132148 | 0302.1 |
| P—VALVE | 7416495 | 0302.1 |

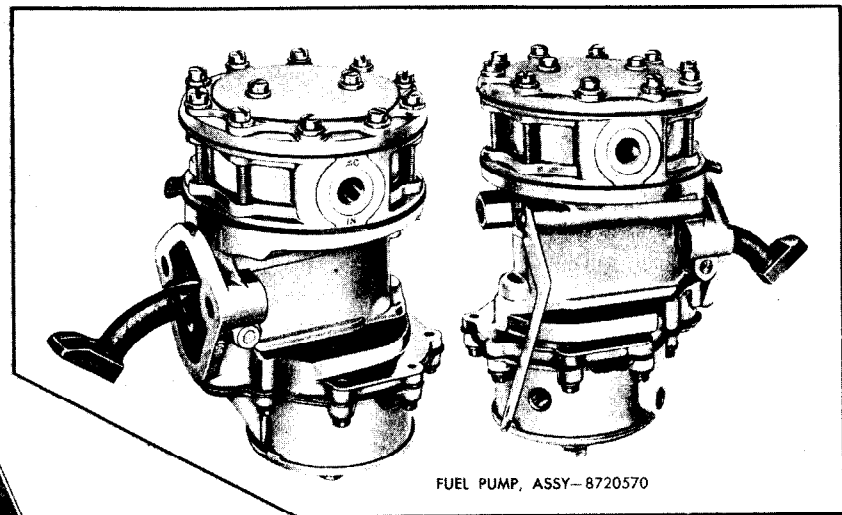

FUEL PUMP, ASSY—8720570

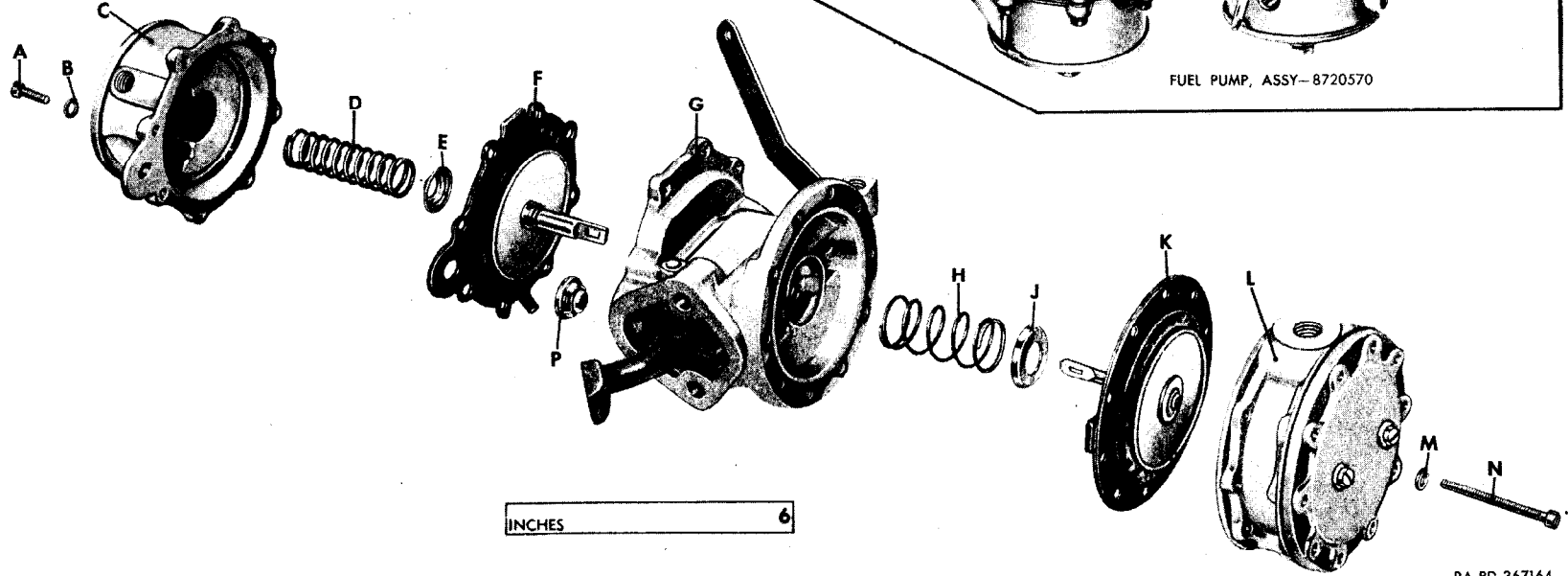

64

Figure 03-2. Fuel and vacuum pump, assy (8720570)—exploded view

RA PD 367164

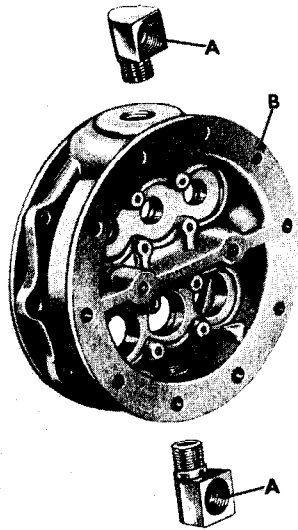

| KEY ITEM | PART NO. | GROUP |
|-------------|------------|--------|
| A—ELBOW | 137422 | 0306 |
| B—BODY | 7375381 | 0302.1 |
| C—GASKET | 7001906 | 0302.1 |
| D—VALVE | 7416495 | 0302.1 |
| E—RETAINER | 7010695 | 0302.1 |
| F—SCREW | 121839 | 0302.1 |
| G—DIAPHRAGM | AC-1538358 | 0302.1 |
| H—COVER | 7016403 | 0302.1 |
| J—WASHER | 120217 | 0302.1 |
| K—SCREW | 132124 | 0302.1 |

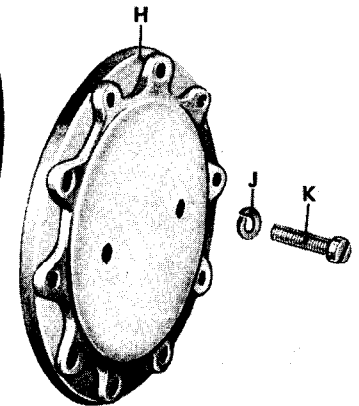
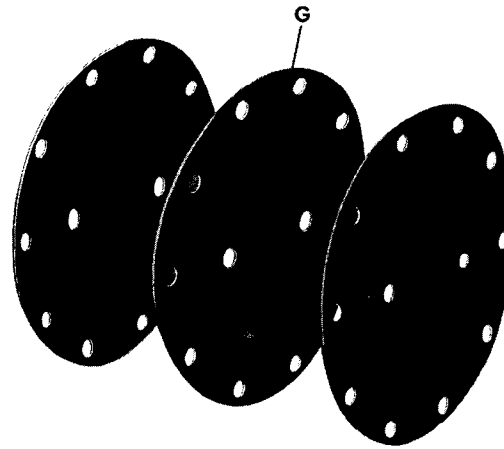
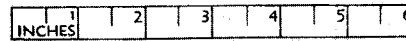
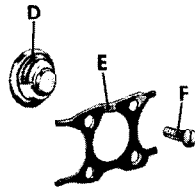

RA PD 367270

Figure 03-3. Fuel and vacuum pump (fuel section)—exploded view

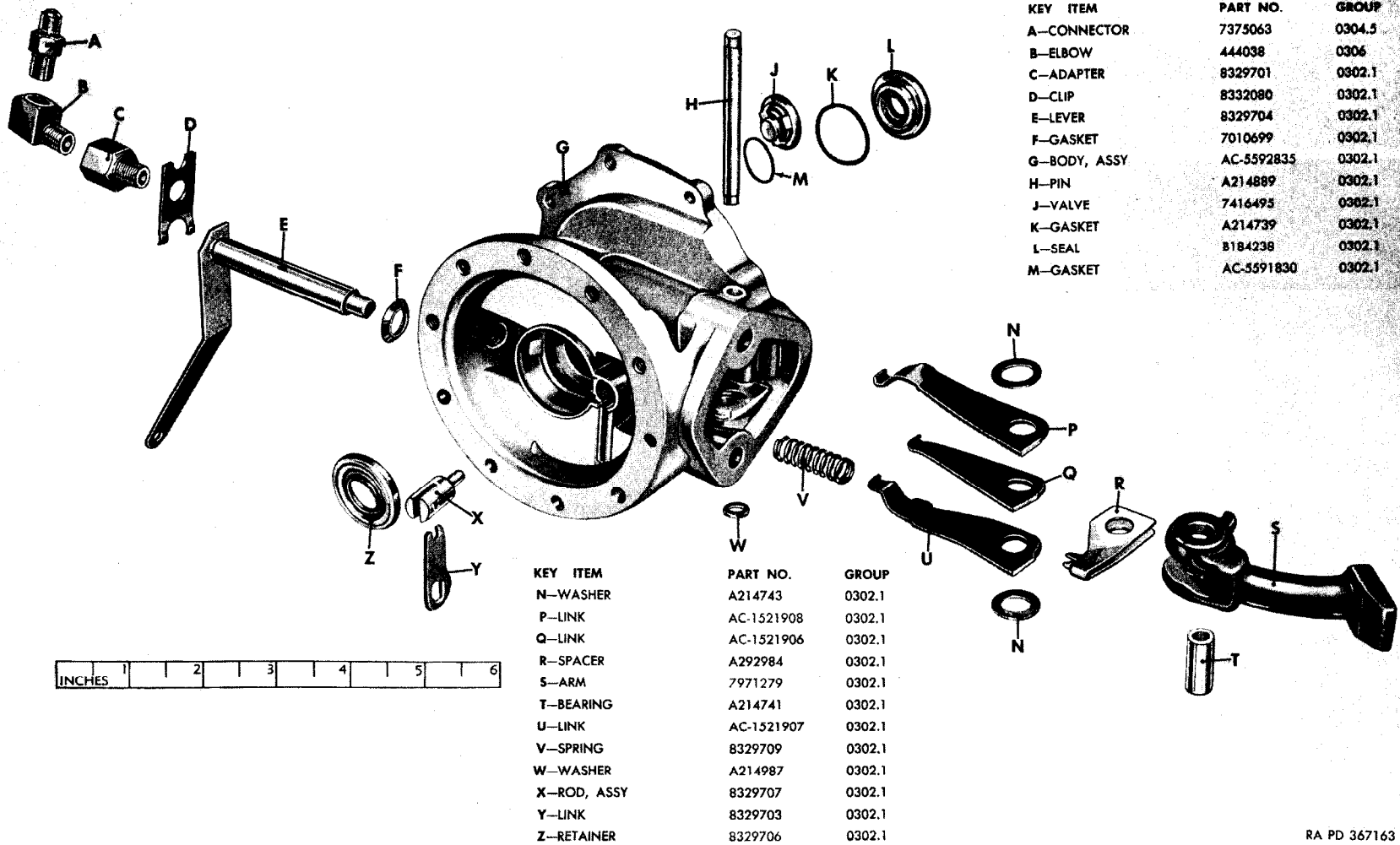
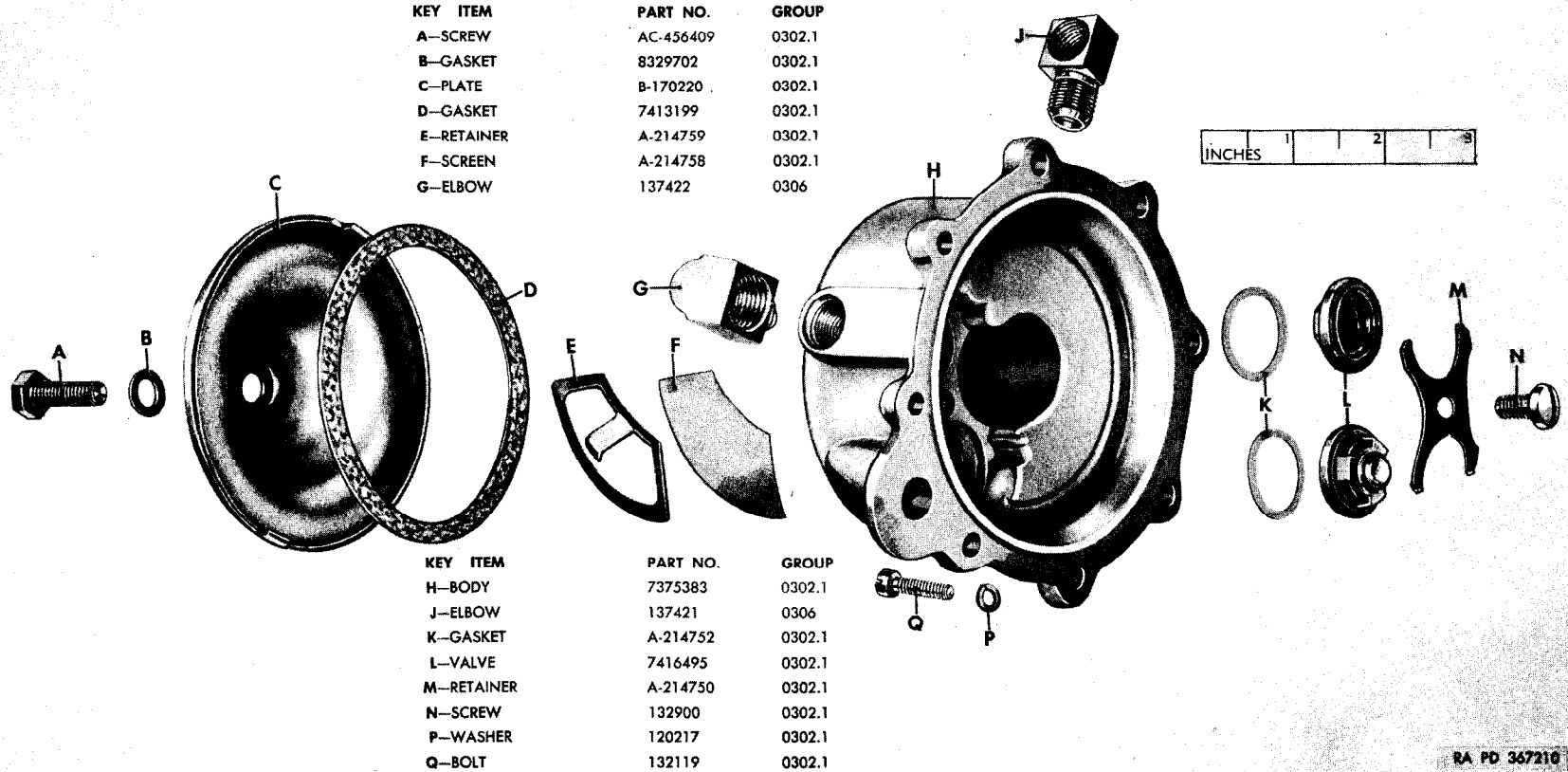
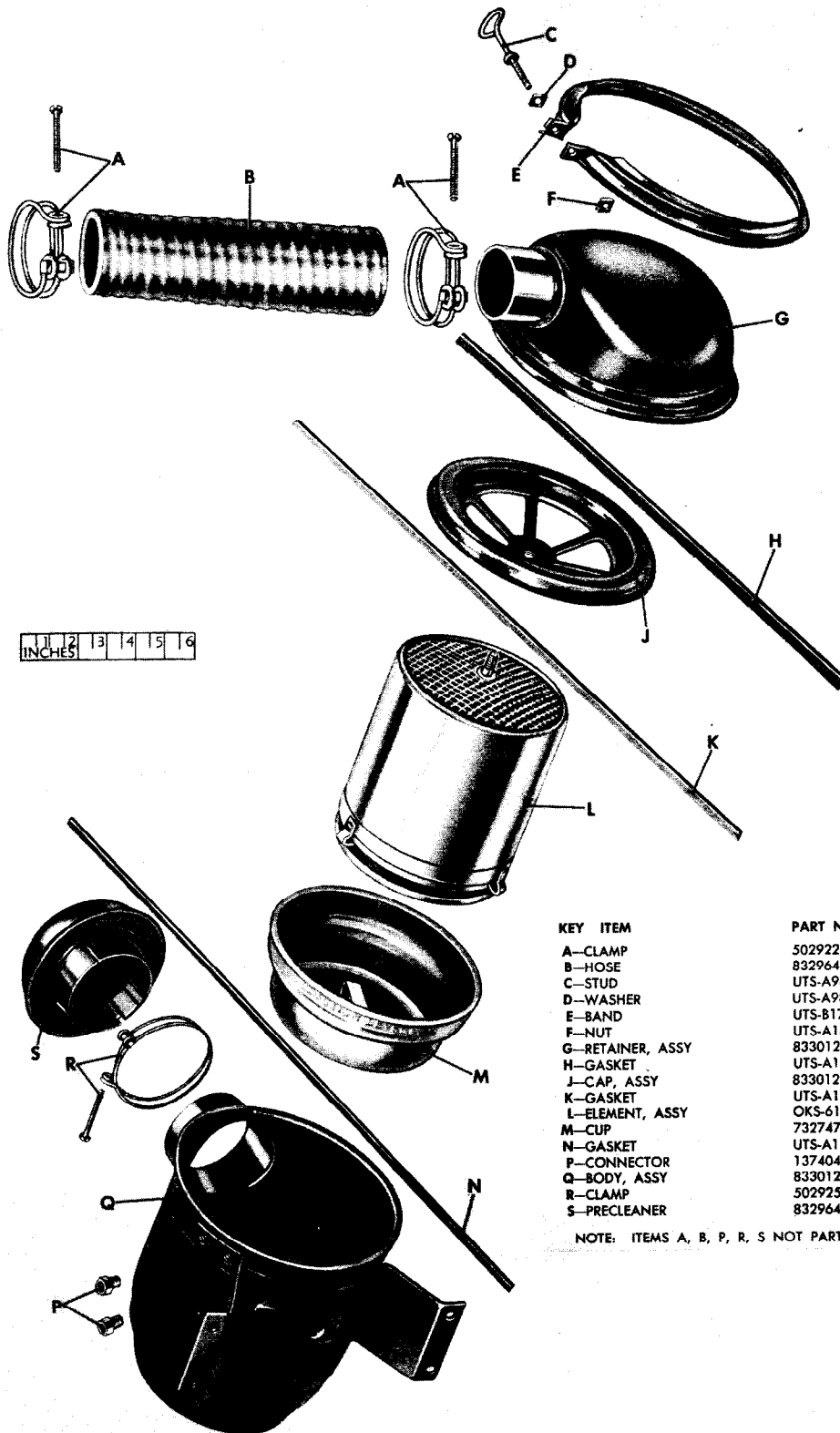

Figure 03-4. Fuel and vacuum pump (body section)—exploded view



BA PD 367210

Figure 03-5. Fuel and vacuum pump (vacuum section)—exploded view



| KEY ITEM | PART NO. | GROUP |
|------------------|------------|--------|
| A—CLAMP | 502922 | 0304.1 |
| B—HOSE | 8329645 | 0304.5 |
| C—STUD | UTS-A9896 | 0304.1 |
| D—WASHER | UTS-A9894 | 0304.1 |
| E—BAND | UTS-B17793 | 0304.1 |
| F—NUT | UTS-A1453 | 0304.1 |
| G—RETAINER, ASSY | 8330125 | 0304.1 |
| H—GASKET | UTS-A17778 | 0304.1 |
| J—CAP, ASSY | 8330126 | 0304.1 |
| K—GASKET | UTS-A17781 | 0304.1 |
| L—ELEMENT, ASSY | OKS-613387 | 0304.1 |
| M—CUP | 7327479 | 0304.1 |
| N—GASKET | UTS-A17779 | 0304.1 |
| P—CONNECTOR | 137404 | 0304.5 |
| Q—BODY, ASSY | 8330127 | 0304.1 |
| R—CLAMP | 502925 | 0304.5 |
| S—PRECLEANER | 8329647 | 0304.1 |

NOTE: ITEMS A, B, P, R, S NOT PART OF THIS ASSY

RA PD 367236

Figure 03-6. Air cleaner, assy (8329642)—exploded view

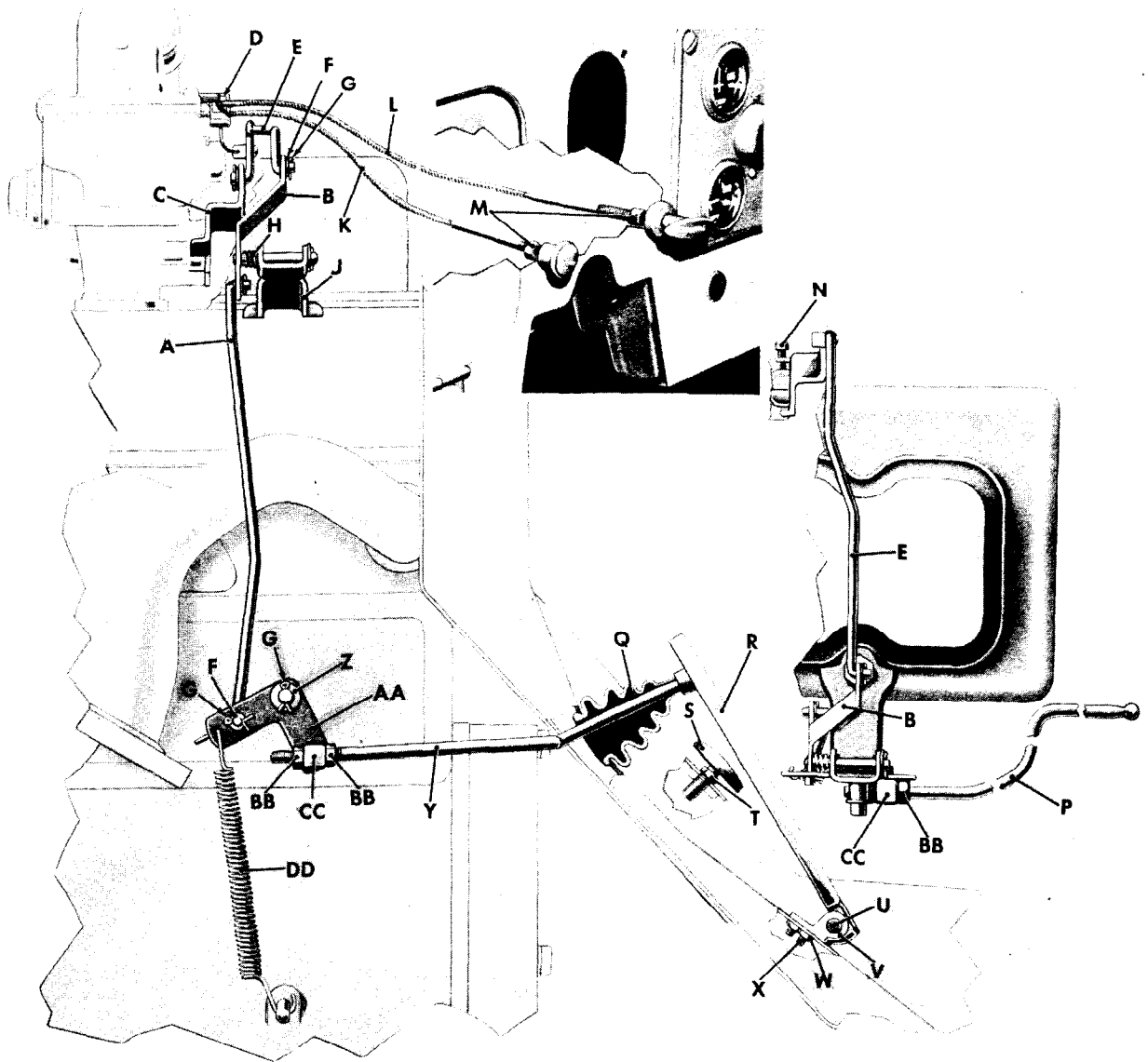

| KEY | ITEM | PART NO. | GROUP | KEY | ITEM | PART NO. | GROUP |
|-----|---------------|----------|-------|-----|------------------|----------|-------|
| A | ROD | 8329765 | 0312 | Q | SEAL | 7361994 | 0312 |
| B | LEVER | 8329769 | 0312 | R | PEDAL | 8333364 | 0312 |
| C | SHAFT, ASSY | 8329833 | 0301 | S | REST | 7375392 | 0312 |
| D | STOP | 7371194 | 0312 | T | NUT | 124920 | 0312 |
| E | ROD | 8329763 | 0312 | U | PIN | 7375112 | 0312 |
| F | WASHER | 502243 | 0312 | V | HINGE | 7375114 | 0312 |
| G | PIN | 121223 | 0312 | W | NUT | 271166 | 0312 |
| H | SPRING | 8329770 | 0312 | X | BOLT | 155937 | 0312 |
| J | BRACKET | 8329768 | 0312 | Y | ROD | 8333365 | 0312 |
| K | CONTROL, ASSY | 8329760 | 0312 | Z | WASHER | 120393 | 0312 |
| L | CONTROL, ASSY | 8329761 | 0312 | AA | LEVER, W/BUSHING | 8330947 | 0312 |
| M | NUT | 271193 | 0312 | BB | NUT | 120367 | 0312 |
| N | SCREW | A-293056 | 0301 | CC | BLOCK | 8329759 | 0312 |
| P | ROD | 8677502 | 0312 | DD | SPRING | 8330948 | 0312 |

RA PD 367211

Figure 03-7. Throttle and choke control

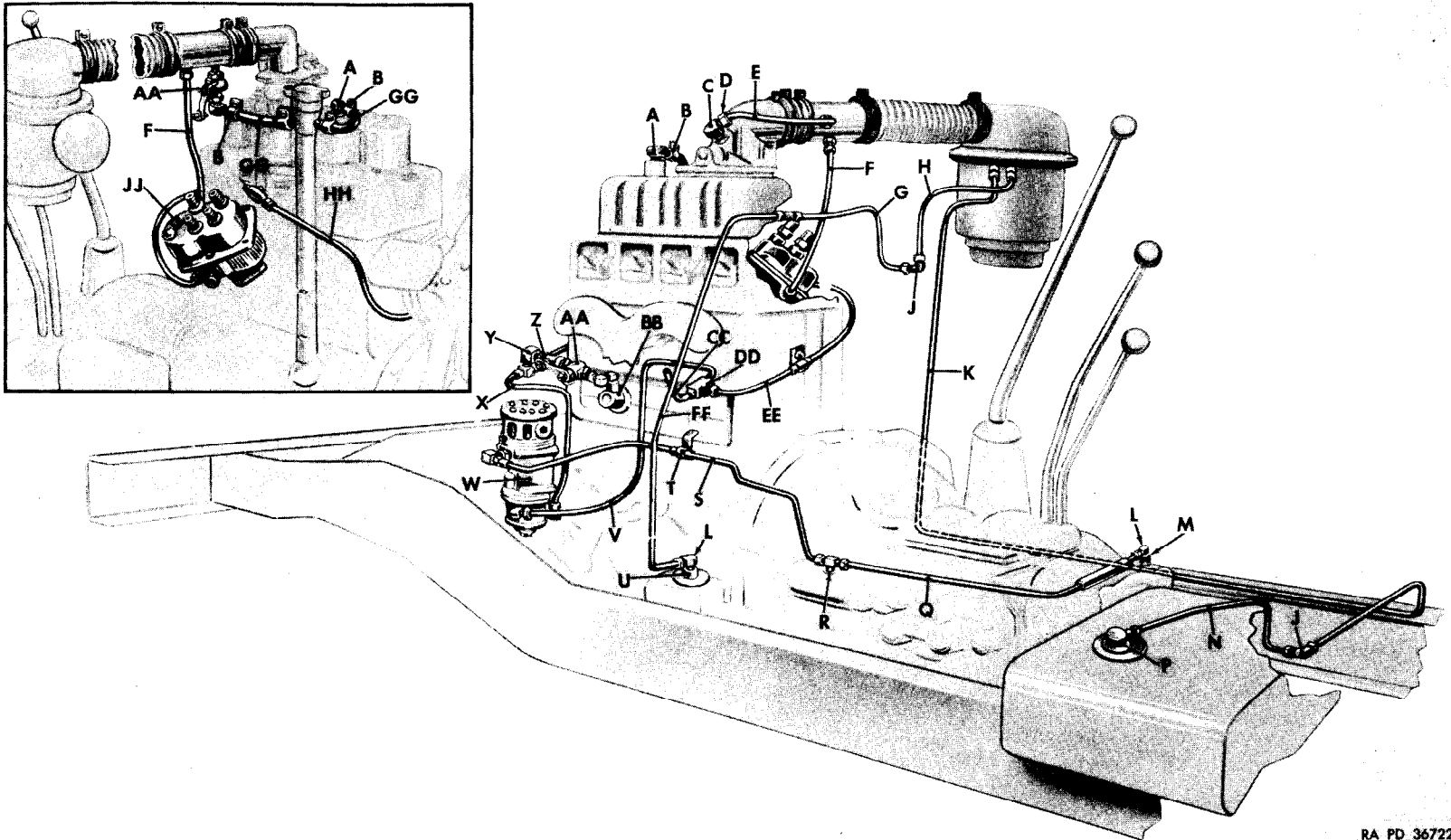

Figure 03-8. Ventilating system

| <i>Key</i> | <i>Item</i> | <i>Part No.</i> | <i>Group</i> |
|------------|-------------------------|-----------------|--------------------|
| A | -ELBOW..... | 8329715 | 0105.2 |
| B | -CLAMP..... | 8330945 | 0304.1 |
| C | -ELBOW..... | 8677538 | 0304.5 |
| D | -NUT..... | 142431 | 0304.5 |
| E | -LINE, ASSY..... | 8677523 | 0304.5 |
| F | -LINE, ASSY..... | 8673356 | 0304.5 |
| G | -LINE, ASSY..... | 8677028 | 0304.5 |
| H | -LINE, ASSY..... | 8677619 | 0304.5 |
| J | -ELBOW..... | 325200 | 0304.5 |
| K | -LINE, ASSY..... | WO-807810 | 0304.5 |
| L | -ELBOW..... | 137420 | 0304.5 |
| M | -COUPLING..... | 7375128 | 0304.5 |
| N | -LINE, ASSY..... | WO-807811 | 0304.5 |
| P | -VALVE..... | 8332556 | 0304.5 |
| Q | -LINE, ASSY..... | 8329638 | 0304.5 |
| R | -UNION..... | 137412 | 0304.5 |
| S | -LINE, ASSY..... | 8329640 | 0304.5 |
| T | -CLIP..... | 5229645 | 2202 |
| U | -CAP..... | 7411069 | 1204.1 |
| V | -LINE, ASSY..... | 8330238 | 2202 |
| W | -PUMP, ASSY..... | 8720570 | 0302.1 |
| X | -LINE, ASSY..... | 8329606 | 0304.5 |
| Y | -ELBOW..... | 8329637 | 0304.5 |
| Z | -VALVE, ASSY..... | 5336400 | 0304.5 |
| AA | -VALVE, ASSY..... | 7410836 | { 0106.5 0304.5 |
| BB | -VENTILATOR, ASSY..... | 7371286 | 0106.5 |
| CC | -LINE, ASSY..... | 8332076 | 2202 |
| DD | -TEE..... | 178910 | 2202 |
| EE | -LINE, ASSY..... | 8673357 | 0304.5 |
| FF | -LINE, ASSY..... | WO-806428 | 0304.5 |
| GG | -HOSE..... | 8332675 | 0304.1 |
| HH | -LINE, ASSY..... | 8329639 | 0304.5 |
| JJ | -DISTRIBUTOR, ASSY..... | 7358569 | 0604.1 |

Figure 03-8. Ventilating system—legend

| KEY ITEM | PART NO | GROUP |
|-----------------------|------------|--------|
| A—SCREW | 159592 | 0304.5 |
| B—VALVE | 8332556 | 0304.5 |
| C—GASKET | ACK-DK149 | 0309 |
| D—SCREW, W/LOCKWASHER | 8332077 | 0309 |
| E—PLATE, ASSY | 8677508 | 0309 |
| F—NUT | 120361 | 0309 |
| G—WASHER | 120217 | 0309 |
| H—SCREW | 132844 | 0309 |
| J—PLATE, ASSY | 8677525 | 0309 |
| K—ELEMENT | 7351316 | 0309 |
| L—PLATE | WO-802608 | 0309 |
| M—SCREW | 455268 | 0309 |
| N—GASKET | 7351315 | 0309 |
| P—BOLT, W/LOCKWASHER | 8332524 | 0610 |
| Q—UNIT | 8329687 | 0610 |
| R—GASKET | 7375146 | 0610 |
| S—BOLT | 9409098 | 0306 |
| T—STRAP | 8329782 | 0306 |
| U—ANTI-SQUEAK | 8329615 | 0306 |
| V—ANTI-SQUEAK | 7375012 | 0306 |
| W—ANTI-SQUEAK | 8329613 | 0306 |
| X—ANTI-SQUEAK | 8329614 | 0306 |
| Y—PLUG | 127951 | 0306 |
| Z—SEAL | 8330946 | 0306 |
| AA—TANK | 8329621 | 0306 |
| BB—GROMMET | 7375036 | 0306 |
| CC—STRAINER | 8329781 | 0306 |
| DD—GASKET | 7375020 | 0306 |
| EE—CAP, ASSY | EAT-CD2616 | 0306 |

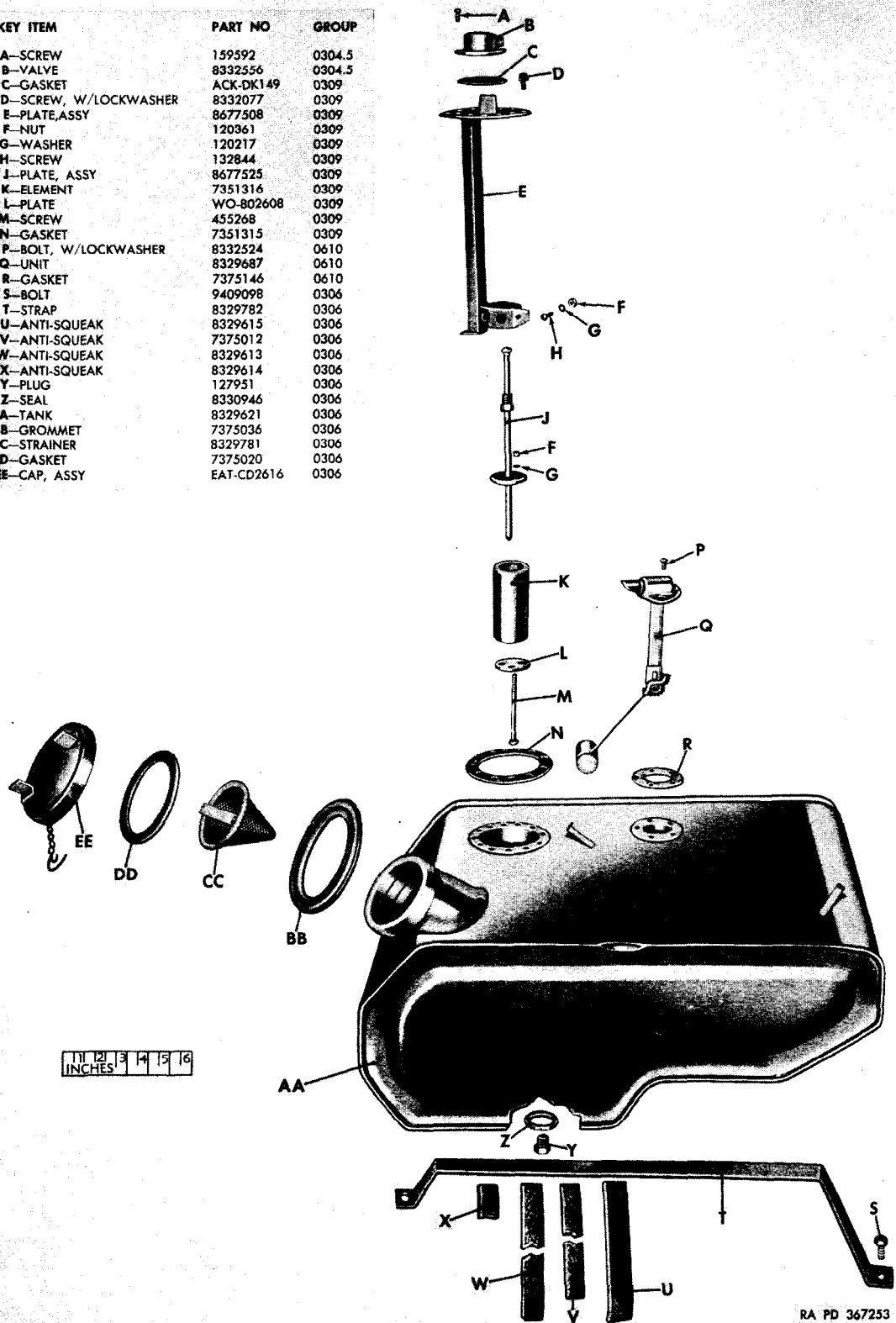

Figure 03-9. Fuel tank and related parts—exploded view

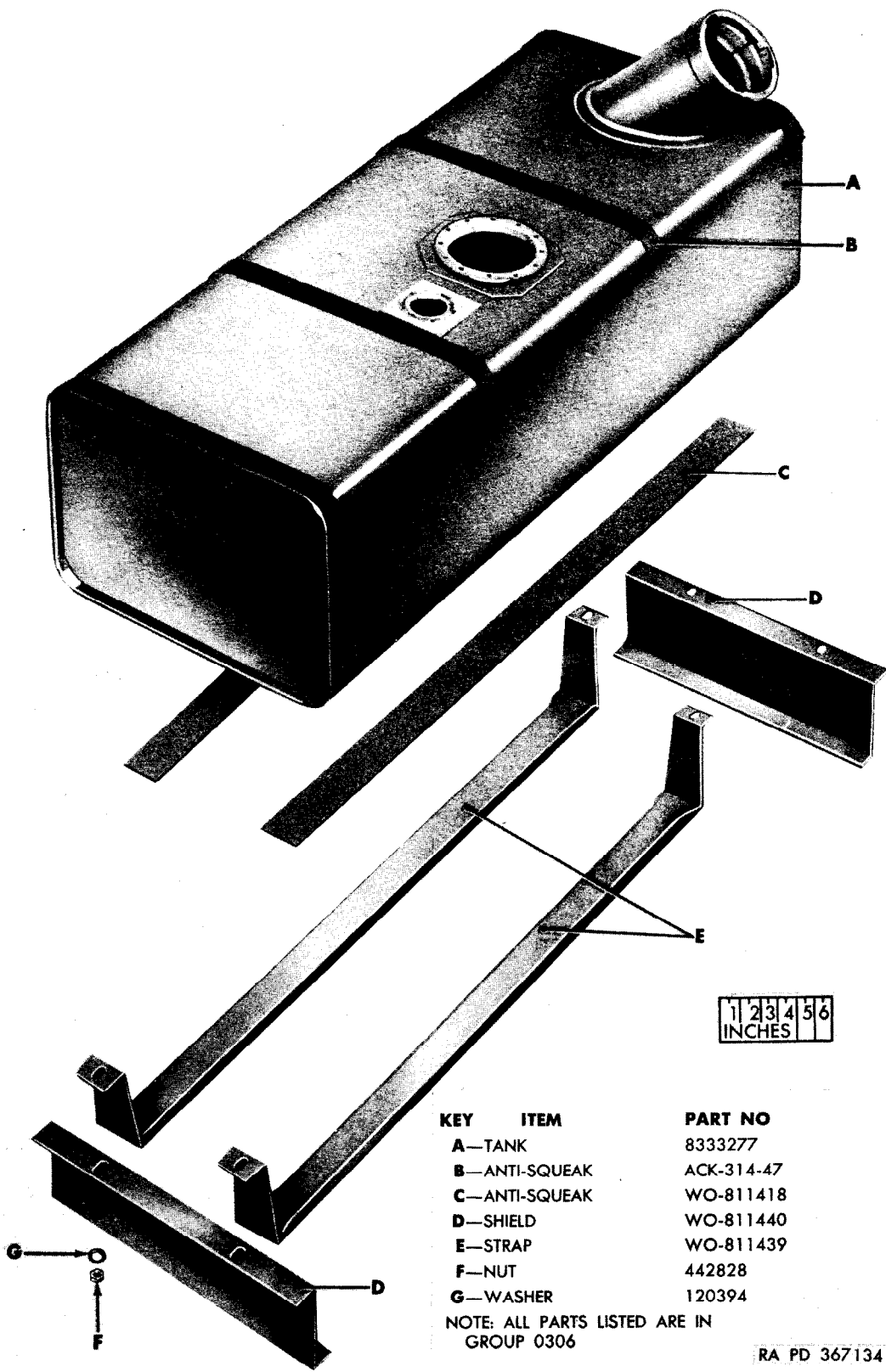
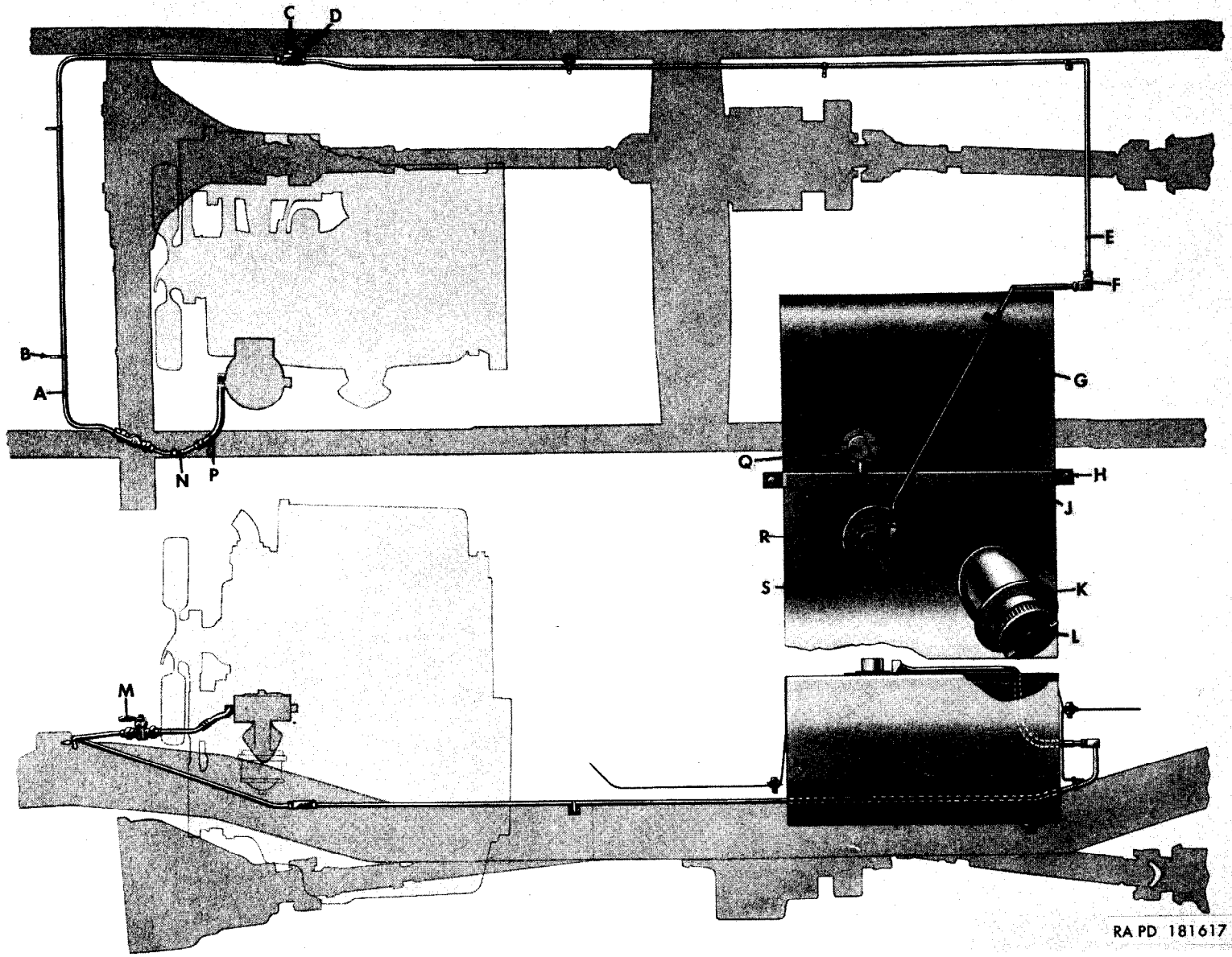

Figure 08-10. Fuel tank and related parts (M170)—exploded view



RA PD 181617

Figure 03-11. Fuel system

| <i>Key</i> | <i>Item</i> | <i>Part No.</i> | <i>Group</i> |
|------------|-------------------|-----------------|--------------|
| A | -LINE, ASSY..... | WO-809403 | 0306 |
| B | -CLIP..... | 127753 | 0306 |
| C | -PLUG..... | 143932 | 0306 |
| D | -TEE..... | 128275 | 0306 |
| E | -LINE, ASSY..... | 8329775 | 0306 |
| F | -ELBOW..... | WO-806177 | 0306 |
| G | -LINE, ASSY..... | WO-808925 | 0306 |
| H | -BOLT..... | 9409098 | 0306 |
| J | -STRAP..... | 8329782 | 0306 |
| K | -GROMMET..... | 7375036 | 0306 |
| L | -CAP, ASSY..... | EAT-CD2616 | 0306 |
| M | -VALVE..... | 7346871 | 0306 |
| N | -LINE, ASSY..... | WO-809404 | 0306 |
| P | -LINE..... | 8331933 | 0306 |
| Q | -UNIT, ASSY..... | 8329687 | 0610 |
| R | -PLATE, ASSY..... | 8677507 | 0309 |
| S | -TANK..... | 8329621 | 0306 |

Figure 03-11. Fuel system—legend

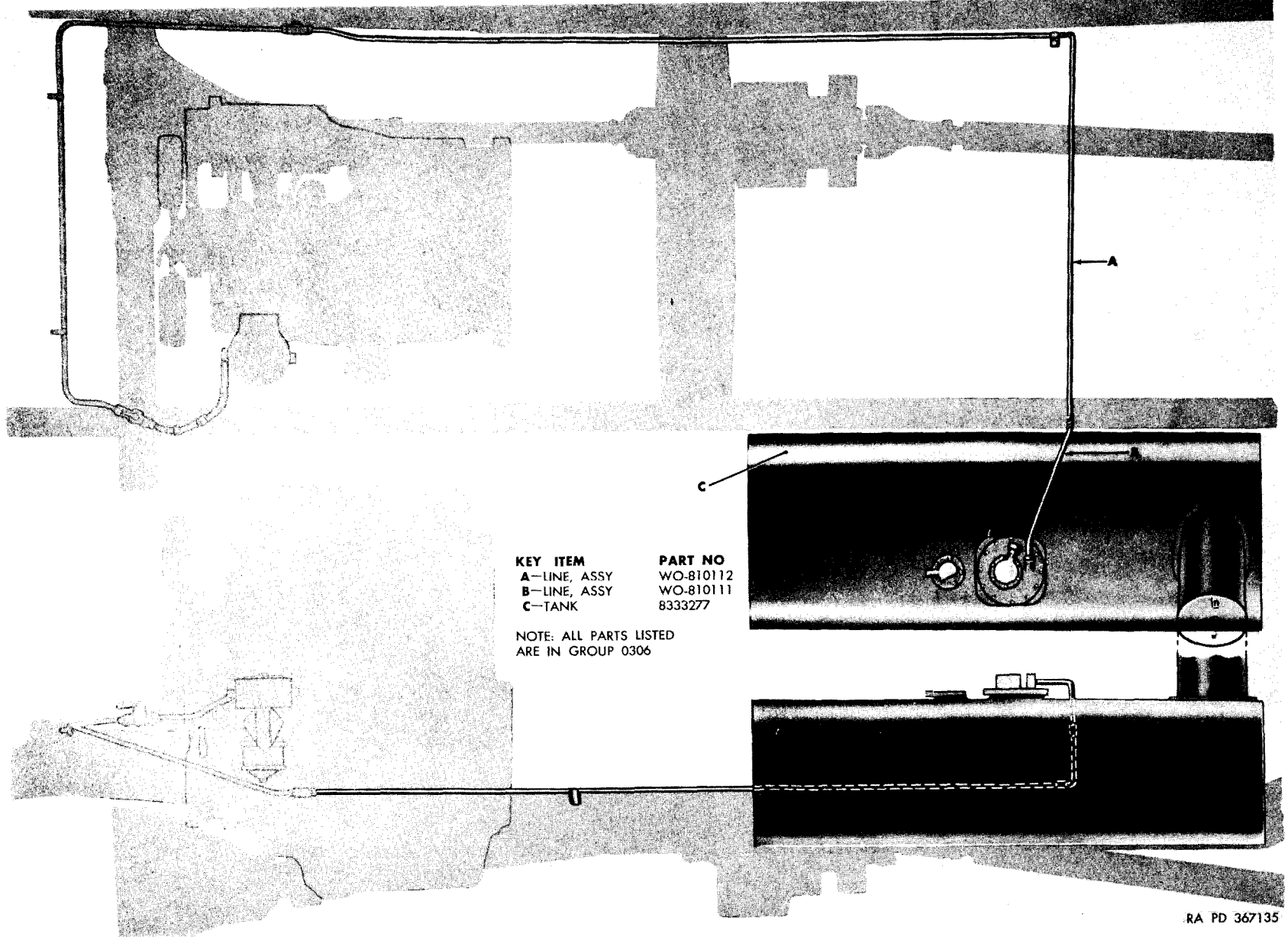

Figure 03-12. Fuel system (M170)

| (1) | (2) | (3) | (4) | (5) | (6) | (7) | (8) | (9) |
|------------------|-------------------|-------------------|--------------------|---|-------------------|--|-------------------------------|---------------|
| ILLUSTRATION NO. | REFERENCE SYMBOLS | FEDERAL STOCK NO. | ORDNANCE STOCK NO. | MFR'S PART NO. | ORDNANCE PART NO. | DESCRIPTION | QUANTITY INCORPORATED IN UNIT | UNIT OF ISSUE |
| | | | | | | GROUP 03—FUEL SYSTEM | | |
| | | | | | | 0301—CARBURETOR | | |
| 03-1 | | 2910-737-2500 | G740-7372500 | CAR-24-26 WO-116880 | 7372500 | AXLE, float lever..... | 1 | ea |
| 03-1 | | 2910-534-6738 | G507-5346738 | CAR-116-13 WO-116813 | A346738 | BALL, check, pump discharge..... | 1 | ea |
| 03-1 | | | G740-7412959 | CAR-122-64S WO-116205 | 7412959 | BALL, fuel intake, assy..... | 1 | ea |
| 03-1 | | 2910-737-2502 | G740-7372502 | CAR-0-570S WO-116868 | 7372502 | BODY, carburetor, assy..... | 1 | ea |
| 03-1 | | | | CAR-6-802 | | BODY, choke valve..... | 1 | ea |
| | | | G758-8329771 | CAR-6-804S WO-119751 | 8329771 | BODY, choke valve, assy..... | 1 | ea |
| 03-1 | | | G507-5293063 | CAR-101-160S WO-116892 | A293063 | SCREW, lock washer, fil-hd, S, zn-pltd, No. 10-32NF x $\frac{5}{16}$ | 6 | ea |
| 03-1 | | | | CAR-1-897 | | BODY, throttle valve..... | 1 | ea |
| | | | G758-8329772 | CAR-1-899S WO-119750 | 8329772 | BODY, throttle valve, assy..... | 1 | ea |
| 03-1 | | | G740-7372520 | CAR-101-149S WO-116891 | 7372520 | SCREW, lock washer, fil-hd, No. 12-28NF x $\frac{3}{4}$ | 3 | ea |
| 03-1 | | | G758-8329773 | CAR-62-185S WO-119745 | 8329773 | BRACKET, choke tube, assy..... | 1 | ea |
| 03-1 | | 5305-734-3368 | G503-7343368 | CAR-101-142S WO-116384 | 7343368 | SCREW, lock washer, fil-hd, No. 8-32NF x $\frac{5}{16}$ | 2 | ea |
| 03-1 | H1 | 5305-012-0221 | H001-5148251 | | 120221 | SCREW, mach, rd-hd, S, cd- or zn-pltd, No. 10 (0.190)- 24NC-2 x $\frac{1}{2}$ | 2 | ea |
| 01-4, 03-1 | | | G758-8329774 | CAR-YS950S WO-804826 | 8329774 | CARBURETOR, assy..... | 1 | ea |
| | | | G758-8332520 | WO-630004 | 8332520 | NUT, PLAIN, HEXAGON, lt, long, S, $\frac{3}{8}$ -24NF-2 | 1 | ea |
| 01-5 | H1 | | H101-0178453 | | 178453 | STUD, S, cd- or zn-pltd, $\frac{3}{8}$ -16NC ($\frac{9}{16}$) x $\frac{3}{8}$ -24NF-2 ($\frac{5}{8}$) x $1\frac{1}{16}$ (carburetor mounting) | 2 | ea |
| 03-1 | | | G758-8329825 | CAR-62-183 WO-119743 | 8329825 | CLAMP, choke control conduit..... | 1 | ea |
| 03-1 | H1 | 012-0619 | H001-4051541 | | 120619 | NUT, PLAIN, SQUARE, mach screw, S, cd- or zn- pltd, No. 10 (0.190)-24NC-2 | 2 | ea |
| | | | G758-8329836 | CAR-62-184S WO-119744 CAR-62-183S | 8329836 | CLAMP, choke control conduit, assy..... | 1 | ea |

77

0301

0301

| (1) | (2) | (3) | (4) | (5) | (6) | (7) | (8) | (9) |
|---------------------------------------|-------------------|-------------------|--------------------|---------------------------|-------------------|---|-------------------------------|---------------|
| ILLUSTRATION NO. | REFERENCE SYMBOLS | FEDERAL STOCK NO. | ORDNANCE STOCK NO. | MFR'S PART NO. | ORDNANCE PART NO. | DESCRIPTION | QUANTITY INCORPORATED IN UNIT | UNIT OF ISSUE |
| GROUP 03—FUEL SYSTEM—Continued | | | | | | | | |
| 0301—CARBURETOR—Continued | | | | | | | | |
| 03-1 | | 2910-495-1772 | G740-7372511 | CAR-203-34S WO-116907 | 7372511 | DIAPHRAGM, metering rod, assy..... | 1 | ea |
| 03-1 | | 2910-495-1773 | G740-7372512 | CAR-203-35S WO-116908 | 7372512 | DIAPHRAGM, pump, assy..... | 1 | ea |
| 03-1 | | 2910-737-2513 | G740-7372513 | CAR-21-95S WO-116879 | 7372513 | FLOAT, w/LEVER, assy..... | 1 | ea |
| 03-1 | | | G758-8329826 | CAR-121-222 WO-119747 | 8329826 | GASKET, body, throttle valve..... | 1 | ea |
| 03-1 | | 2910-495-1697 | G740-7372514 | CAR-121-138 WO-116896 | 7372514 | GASKET, choke valve body to float body..... | 1 | ea |
| 03-1 | | 5330-360-8007 | G503-5293029 | CAR-20-22 WO-116168 | A293029 | GASKET, float needle valve seat..... | 1 | ea |
| 03-1 | | | G741-5293030 | CAR-20-35 WO-116784 | A293030 | GASKET, fuel inlet strainer nut..... | 1 | ea |
| 03-1 | | 2910-453-6534 | G503-7378054 | CAR-20-61 WO-116170 | 7378054 | GASKET, pump passage plug..... | 1 | ea |
| 03-1 | | 2910-737-2518 | G740-7372518 | CAR-170-139 WO-116906 | 7372518 | HOUSING, metering rod diaphragm..... | 1 | ea |
| 03-1 | | 2910-737-2517 | G740-7372517 | CAR-170-138 WO-116905 | 7372517 | HOUSING, pump diaphragm..... | 1 | ea |
| 03-1 | | | G740-7372527 | CAR-101-221S WO-116893 | 7372527 | SCREW, lock washer, fil-hd, No. 8-32NC x 5/8..... | 8 | ea |
| 03-1 | | | G758-8329828 | WO-806271 | 8329828 | INSULATOR, throttle valve flange to manifold..... | 1 | ea |
| 03-1 | | | | CAR-145-69 | | JET, body, choke valve..... | 1 | ea |
| 03-1 | | | | CAR-48-144 | | JET, carburetor body..... | 1 | ea |
| 03-1 | | 2910-737-2519 | G740-7372519 | CAR-120-157 WO-116894 | 7372519 | JET, metering rod..... | 1 | ea |
| 03-1 | | | | CAR-61-79 | | LOCK, choke valve to poppet valve plug..... | 1 | ea |
| 03-1 | | | | CAR-17-49 | | NEEDLE, intake valve..... | 1 | ea |
| 03-1 | | | | CAR-15-43 | | NUT, strainer, fuel inlet..... | 1 | ea |
| 03-1 | | 5310-737-2521 | G740-7372521 | CAR-15-44S WO-116878 | 7372521 | NUT, strainer, w/GASKET, assy..... | 1 | ea |
| 03-1 | | 5305-453-6491 | G503-7378099 | CAR-150-98 WO-116177 | 7378099 | PIN, intake needle spring..... | 1 | ea |
| 03-1 | | 5315-737-2522 | G740-7372522 | CAR-150-139 WO-116901 | 7372522 | PIN, metering rod sleeve..... | 1 | ea |
| 03-1 | | | G758-8329830 | CAR-7-178S WO-119740 | 8329830 | PLATE, choke valve to poppet valve, assy..... | 1 | ea |

78

| | | | | | | | |
|---------|---------------|--------------|--|---------|---|--------|----------|
| 03-1 | | G503-5281457 | CAR-39-10 WO-116216 | A281457 | SCREW, rd-hd, br, No. 3-48 x $\frac{3}{16}$ | 2 | ea |
| 03-1 | | | CAR-148-12 | | PLATE, choke valve to poppet valve, lower..... | 1 | ea |
| 03-1 | | | CAR-7-177 | | PLATE, choke valve to poppet valve, upper..... | 1 | ea |
| 03-1 | | G758-8329831 | CAR-2-134 WO-118061 | 8329831 | PLATE, throttle valve..... | 1 | ea |
| 03-1 | | G085-3005020 | CAR-39-11 WO-116217 | A346734 | SCREW, rd-hd, br, No. 3-48NC x $\frac{1}{16}$ | 2 | ea |
| 03-1 | 2910-737-2525 | G740-7372525 | CAR-11B176 WO-116876 | 7372525 | PLUG, choke shaft..... | 1 | ea |
| 03-1 | | | CAR-136-17 | | PLUG, choke valve to poppet valve plate..... | 1 | ea |
| 03-1 | | | CAR-47-23 WO-116884 | | PLUG, expansion throttle shaft..... | 1 | ea |
| 03-1 | 2910-360-8027 | G502-7324060 | CAR-11B79 WO-116160 | 7324060 | PLUG, idle passage (rivet)..... | 1 | ea |
| 03-1 | 4730-531-2057 | G507-5312057 | CAR-11B108 WO-116162 | A312057 | PLUG, idle port passage (rivet)..... | 1 | ea |
| 03-1 | | | CAR-11B134 WO-116875 | | PLUG, intake, needle passage..... | 1 | ea |
| 03-1 | | G085-3004220 | CAR-11B12 WO-119741 | A281413 | PLUG, passage (rivet)..... | 2 | ea |
| 03-1 | 2910-366-6569 | G502-7324058 | CAR-11B41 WO-116647 | 7324058 | PLUG, pump inlet passage (rivet)..... | 1 | ea |
| 03-1 | 2910-360-8013 | G503-7378081 | CAR-11B124 CAR-11B125S WO-116163 | 7378081 | PLUG, pump passage..... PLUG, strainer passage, w/GASKET, assy..... | 1 1 | ea ea |
| 03-1 | | G758-8329832 | CAR-75-826S WO-119746 | 8329832 | ROD, metering, assy..... | 1 | ea |
| 03-1, 7 | | G716-5293056 | CAR-101-120 WO-116651 | A293056 | SCREW, adjusting, throttle lever..... | 1 | ea |
| 03-1 | 5305-366-6546 | G505-5346736 | CAR-30A37 WO-116883 | A346736 | SCREW, idle adjustment..... | 1 | ea |
| 03-1 | H1 | H001-5125821 | | 131958 | SCREW, mach, fil-hd, S, cd- or zn-pltd, No. 8-32NC-2 x $\frac{5}{16}$ (choke wire clamp) | 1 | ea |
| 03-1 | 5330-495-1756 | G740-7372528 | CAR-163-21 WO-116902 | 7372528 | SEAL, choke shaft..... | 1 | ea |
| 03-1 | 5330-495-1757 | G740-7372530 | CAR-163-28 WO-116903 | 7372530 | SEAL, dust throttle shaft..... | 1 | ea |
| 03-1 | 5330-495-1758 | G740-7372529 | CAR-163-46 WO-116904 | 7372529 | SEAL, idle adjusting screw..... | 1 | ea |
| 03-1 | | | CAR-25-149 | | SEAT, needle valve..... | 1 | ea |
| 03-1 | 2910-737-2531 | G740-7372531 | CAR-14-359S WO-116877 | 7372531 | SHAFT, choke, w/LEVER, assy..... | 1 | ea |
| 03-1, 7 | | G758-8329833 | CAR-3-773S WO-119739 | 8329833 | SHAFT, throttle valve, w/LEVER, assy..... | 1 | ea |
| 03-1 | | | CAR-112-12 | | SLEEVE, choke valve to poppet valve plug..... | 1 | ea |
| 03-1 | | | CAR-51-21 | | SPRING, choke valve to poppet valve plates..... | 1 | ea |

10301

80

| (1) ILLUSTRATION NO. | (2) REFERENCE SYMBOLS | (3) FEDERAL STOCK NO. | (4) ORDNANCE STOCK NO. | (5) MFR'S PART NO. | (6) ORDNANCE PART NO. | (7) DESCRIPTION | (8) QUANTITY INCORPORATED IN UNIT | (9) UNIT OF ISSUE |
|---------------------------------------|--------------------------|--------------------------|---------------------------|--------------------------|--------------------------|---|--------------------------------------|----------------------|
| GROUP 03—FUEL SYSTEM—Continued | | | | | | | | |
| 0301—CARBURETOR—Continued | | | | | | | | |
| 03-1 | | | | CAR-61-426 WO-118548 | | SPRING, idle adjusting screw..... | 1 | ea |
| 03-1 | | 5340-360-8039 | | CAR-61-207 WO-116191 | | SPRING, intake needle..... | 1 | ea |
| 03-1 | | 5340-737-2534 | G740-7372534 | CAR-61-356 WO-116887 | 7372534 | SPRING, metering rod..... | 1 | ea |
| 03-1 | | | G758-8329834 | CAR-61-460 WO-119742 | 8329834 | SPRING, pump..... | 1 | ea |
| 03-1 | | | G740-7372533 | CAR-61-357 WO-116888 | 7372533 | SPRING, return, choke valve shaft..... | 1 | ea |
| 03-1 | | 2910-529-3034 | G508-5293034 | CAR-30-14 WO-116882 | A293034 | STRAINER (fuel intake)..... | 1 | ea |
| 03-1 | | 2910-360-8019 | G085-3004900 | CAR-30-20 WO-116175 | A281437 | STRAINER, pump..... | 1 | ea |
| 03-1 | | 2910-737-2537 | G740-7372537 | CAR-145-70S WO-116900 | 7372537 | TUBE, bleeder, w/PLUG, assy..... | 1 | ea |
| 03-1 | | 2910-737-2536 | G740-7372536 | CAR-11A-142 WO-116874 | 7372536 | TUBE, low speed jet..... | 1 | ea |
| | | 2910-737-2538 | G740-7372538 | CAR-25-151S WO-116881 | 7372538 | VALVE, needle, w/SPRING and SEAT, assy..... | 1 | ea |
| 03-1 | | 5310-737-2539 | G740-7372539 | CAR-136-98 WO-116897 | 7372539 | WASHER, retaining, choke valve shaft seal..... | 1 | ea |
| 03-1 | | | G758-8329835 | CAR-136-166 WO-119749 | 8329835 | WASHER, retaining, idle adjusting screw seal..... | 1 | ea |
| | | | G758-8329837 | CAR-136-24 WO-119748 | 8329837 | WASHER, retaining, throttle shaft..... | 1 | ea |
| 03-1 | | | G740-7372541 | CAR-136-99 WO-116898 | 7372541 | WASHER, retaining, throttle valve shaft seal..... | 1 | ea |
| 03-1 | | | G740-7372542 | CAR-221-12 WO-116909 | 7372542 | WEIGHT, pump discharge ball check..... | 1 | ea |
| 0302.1—FUEL AND VACUUM PUMP | | | | | | | | |
| 03-4 | | | G758-8329701 | AC-5592921 WO-119672 | 8329701 | ADAPTER, air vent..... | 1 | ea |
| | | 2910-737-5382 | G740-7375382 | AC-5592295 WO-118476 | 7375382 | ARM, rocker (used w/PUMP 8329705 and PUMP AC-5594069) | 1 | ea |

| | | | | | | | | |
|---------|----|---------------|--------------|--|---------|--|----|----|
| 03-4 | | | G758-7971279 | AC-5593764 WO-120932 | 7971279 | ARM, rocker (used w/PUMP 8720570) | 1 | ea |
| 03-4 | | 3120-386-1436 | G067-1500270 | AC-1523221 WO-117138 | A214741 | BEARING, bushing type, rocker arm pin | 1 | ea |
| 03-2, 3 | | 2910-737-5381 | G740-7375381 | AC-5592291 WO-118475 | 7375381 | BODY, fuel section | 1 | ea |
| 03-2, 4 | | | | AC-5592835 WO-119651 | | BODY, fuel section, w/oil SEAL, assy | 1 | ea |
| 03-2, 5 | | 2910-737-5383 | G740-7375383 | AC-5592300 WO-118488 | 7375383 | BODY, vacuum section | 1 | ea |
| 03-5 | H1 | | H001-5127361 | | 132119 | BOLT, mach, fil-hd, S, cd- or zn-pltd, No. 10-32NF-2 x 5/8 | 8 | ea |
| 03-5 | H1 | 5310-012-0217 | H001-7025621 | | 120217 | WASHER, LOCK, med, S, cd- or zn-pltd, No. 10 | 8 | ea |
| 03-2 | | | G226-5214746 | AC-523259 WO-117143 | A214746 | CAP, diaphragm return spring | 1 | ea |
| 03-4 | | | G758-8332080 | AC-5592920 WO-119848 | 8332080 | CLIP, primer lever | 1 | ea |
| 03-3 | | 2910-701-6403 | G509-7016403 | AC-1538355 WO-118480 | 7016403 | COVER, pulsator diaphragm | 1 | ea |
| | | | G742-7539125 | AC-1567648 WO-118482 | 7539125 | SCREW, mach, fil-hd, S, cd- or zn-pltd, No. 10-32NF-2 x 1 13/16 (superseded by SCREW 132148) | 10 | ea |
| 03-2 | H1 | | H101-0132148 | | 132148 | SCREW, mach, fil-hd, S, cd- or zn-pltd, No. 10 (0.190)-32NF-2 x 1 3/4 (supersedes SCREW 7539125) | 10 | ea |
| 03-3 | H1 | 013-2124 | H001-5127371 | | 132124 | SCREW, mach, fil-hd, S, cd- or zn-pltd, No. 10-32NF-2 x 3/4 | 2 | ea |
| 03-2, 3 | H1 | 5310-012-0217 | H001-7025621 | | 120217 | WASHER, LOCK, med, S, cd- or zn-pltd, No. 10 | 2 | ea |
| 03-2 | | 2530-833-2534 | G758-8332534 | AC-5592898 WO-119867 | 8332534 | DIAPHRAGM, fuel section, w/pull ROD | 1 | ea |
| | | | G671-7001905 | AC-5592893 WO-119847 AC-1538358 WO-118477 | 7001905 | DIAPHRAGM, pulsator, fuel pump | 3 | ea |
| | | 2530-833-2535 | G758-8332535 | AC-5592899 WO-119661 AC-5590460 WO-120264 | 8332535 | DIAPHRAGM, vacuum section, w/pull ROD (used w/PUMP 8329705) | 1 | ea |
| 03-2 | | | | AC-5593181 WO-120123 | | DIAPHRAGM, vacuum section, w/pull ROD (used w/PUMP AC-5594069 and PUMP AC-5594260) | 1 | ea |
| 03-4 | | | G226-5214739 | AC-1523120 WO-118491 | A214739 | GASKET, cork, 1 1/16 ID, 0.990 OD, 0.035 thk (oil seal body) | 1 | ea |
| 03-5 | | 2805-360-7697 | G508-5214752 | AC-1521953 WO-115652 | A214752 | GASKET, 0.012 thk (vacuum section valve to cover) | 2 | ea |

0302.1

82

| (1) | (2) | (3) | (4) | (5) | (6) | (7) | (8) | (9) |
|------------------|-------------------|-------------------|--------------------|--|-------------------|--|-------------------------------|---------------|
| ILLUSTRATION NO. | REFERENCE SYMBOLS | FEDERAL STOCK NO. | ORDNANCE STOCK NO. | MFR'S PART NO. | ORDNANCE PART NO. | DESCRIPTION | QUANTITY INCORPORATED IN UNIT | UNIT OF ISSUE |
| | | | | | | GROUP 03—FUEL SYSTEM—Continued | | |
| | | | | | | 0302.1—FUEL AND VACUUM PUMP—Continued | | |
| | | 2910-360-8044 | G503-5261672 | ACK-CN70S GM-838263 WO-638737 AC-1411094 WO-118704 | 5261672 | GASKET, fuel pump to cylinder block..... | 2 | ea |
| 03-3 | | 2910-700-1906 | G671-7001906 | AC-1538357 WO-118478 | 7001906 | GASKET, fuel section valve..... | 2 | ea |
| 03-4 | | | G758-7010699 | AC-1537811 WO-119656 | 7010699 | GASKET, oil priming lever pin..... | 1 | ea |
| 03-4 | | | AC-5591830 | AC-5591830 WO-118490 | | GASKET, ru, 0.020 thk (vacuum section valve, upper)... | 1 | ea |
| 03-5 | | 5330-741-3199 | G741-7413199 | AC-5592251 WO-119248 | 7413199 | GASKET, vacuum section cover..... | 1 | ea |
| 03-2, 5 | | | G758-8329702 | AC-5590046 WO-117910 | 8329702 | GASKET, vacuum section cover screw..... | 1 | ea |
| 03-4 | | | G758-8329704 | AC-5592836 WO-119658 | 8329704 | LEVER, primer, w/SHAFT, assy..... | 1 | ea |
| 03-4 | | | G758-8329703 | AC-5592406 WO-119657 | 8329703 | LINK, priming lever..... | 1 | ea |
| 03-4 | | | | AC-1521906 WO-116343 | | LINK, rocker arm (intermediate)..... | 1 | ea |
| 03-4 | | | | AC-1521908 WO-116344 | | LINK, rocker arm, left..... | 1 | ea |
| 03-4 | | | | AC-1521907 WO-116345 | | LINK, rocker arm, right..... | 1 | ea |
| 03-4 | | | G508-5214889 | AC-1522023 WO-116329 | A214889 | PIN, sp, S, 0.259 x 3 $\frac{1}{2}$ overall lgh (rocker arm)..... | 1 | ea |
| 03-4 | | | G508-5214987 | AC-1521288 WO-116762 | A214987 | WASHER, flat, S, cd- or zn-pltd, 0.189 ID, $\frac{3}{8}$ OD, 0.042 thk | 1 | ea |
| 03-5 | | 2910-350-2383 | G741-6170220 | AC-1537195 WO-117152 | B170220 | PLATE, vacuum section..... | 1 | ea |
| 03-2, 5 | | | | AC-456409 WO-120946 | | SCREW, cap, hex-hd, S, cd- or zn-pltd, $\frac{1}{4}$ -28NF-3 x $\frac{3}{4}$ | 1 | ea |
| | | | G758-8329705 | AC-1539810 WO-805727 AC-5594069 WO-810289 | 8329705 | PUMP, fuel and vacuum, assy (superseded by PUMP AC-5594069) PUMP, fuel and vacuum assy (supersedes PUMP 8329705) (superseded by PUMP 8720570) | 1 | ea |

| | | | | | | | | |
|------------------|-----|--------------------------------|------------------------------|-------------------------|-------------------|--|----|----|
| 01-1; 03-2, 8 | | | G758-8720570 | AC-5594260 WO-908715 | 8720570 | PUMP, fuel and vacuum, assy (supersedes PUMP AC-5594069) | 1 | ea |
| | H1 | 5305-737-5385 012-2058 | G740-7375385 H101-0122058 | WO-800741 | 7375385 122058 | BOLT, hex-hd, S, cd- or zn-pltd, $\frac{5}{16}$ -18NC-3 x $5\frac{1}{8}$ | 1 | ea |
| | | | | | | BOLT, MACHINE, cap, hex-hd, S, cd- or zn-pltd, $\frac{5}{16}$ -18NC-3 x $1\frac{7}{8}$ (used on engine through serial No. 49065) | 1 | ea |
| | | | G758-8332521 | WO-809689 | 8332521 | BOLT, MACHINE, hex-hd, sp, S, cd- or zn-pltd, $\frac{5}{16}$ -18NC-3 x $3\frac{3}{8}$ (used on engine after serial No. 49065) | 1 | ea |
| | H1 | 5310-012-0214 5310-741-6478 | H001-7025711 G740-7416478 | | 120214 7416478 | WASHER, lock, med, S, cd- or zn-pltd, $\frac{5}{16}$ in..... | 2 | ea |
| | | | | WO-805842 | | WASHER, rectangular, 0.406 dia, 0.660 x 0.940 OD, 0.0598 thk (fuel pump to cylinder block) | 2 | ea |
| 03-2 | | 2910-521-4761 | G102-5214761 | AC-1523805 WO-117156 | A214761 | RETAINER, diaphragm spring..... | 1 | ea |
| 03-4 | | | G758-8329706 | AC-5592332 WO-119242 | 8329706 | RETAINER, main body, oil seal..... | 1 | ea |
| 03-5 | | 2910-521-4759 | G102-5214759 | AC-1523803 WO-117155 | A214759 | RETAINER, vacuum section screen..... | 1 | ea |
| 03-5 | | 2910-368-2627 | G732-5214750 | AC-1523664 WO-117144 | A214750 | RETAINER, valve..... | 1 | ea |
| 03-5 | H1 | | H001-5148831 | | 132900 | SCREW, mach, rd-hd, S, cd- or zn-pltd, No. 10- 32NF-2 x $\frac{3}{8}$ | 1 | ea |
| 03-3 | | 2910-701-0695 | G741-7010695 | AC-1538356 WO-118481 | 7010695 | RETAINER, valve pump..... | 2 | ea |
| 03-3 | H1 | 012-1839 | H001-5146431 | | 121839 | SCREW, mach, rd-hd, S, cd- or zn-pltd, No. 6 (0.138)- 32NC-2 x $\frac{5}{16}$ | 8 | ea |
| 03-4 | | | G758-8329707 | AC-5592409 WO-119659 | 8329707 | ROD, push, w/PIN, assy..... | 1 | ea |
| 03-5 | | 2910-521-4758 | G741-5214758 | AC-1523802 WO-117157 | A214758 | SCREEN, vacuum section..... | 1 | ea |
| 03-4 | | | G104-6184238 | AC-1523122 WO-117432 | B184238 | SEAL, oil, type ML, $\frac{3}{8}$ ID, 1.000 OD, $\frac{5}{16}$ thk (vacuum section) | 1 | ea |
| | | | G758-8329708 | WO-800361 | 8329708 | SPACER, fuel pump to cylinder block..... | 1 | ea |
| 03-4 | | 2910-529-2984 | G102-5292984 | AC-1521909 WO-116346 | A292984 | SPACER, rocker arm link..... | 1 | ea |
| 03-2 | | 5340-350-6003 | G147-0389807 | AC-1537096 WO-119652 | A323138 | SPRING, compression, $1\frac{5}{16}$ OD, 6 coils, 2 in. free lg (diaphragm, fuel section) | 1 | ea |
| 03-4 | | | G758-8329709 | AC-5592839 WO-119653 | 8329709 | SPRING, rocker arm..... | 1 | ea |
| 03-2 | | | | AC-5590533 WO-117160 | | SPRING, vacuum section diaphragm..... | 1 | ea |
| | H16 | | H016-5196397 | | 5196397 | VALVE, air vent (fuel pump) (used on vehicles after serial No. 23359) | 1 | ea |
| 03-2, 3, 4, 5 | | 2910-358-5632 | G262-7416495 | AC-5591860 WO-118486 | 7416495 | VALVE, fuel and vacuum section w/GAGE, assy..... | 10 | ea |

| (1) ILLUSTRATION NO. | (2) REFERENCE SYMBOLS | (3) FEDERAL STOCK NO. | (4) ORDNANCE STOCK NO. | (5) MFR'S PART NO. | (6) ORDNANCE PART NO. | (7) DESCRIPTION | (8) QUANTITY INCORPORATED IN UNIT | (9) UNIT OF ISSUE |
|--|--------------------------|--------------------------|---------------------------|---|--------------------------|---|--------------------------------------|----------------------|
| GROUP 03—FUEL SYSTEM—Continued | | | | | | | | |
| 0302.1—FUEL AND VACUUM PUMP—Continued | | | | | | | | |
| 03-4 | | 5310-741-0270 | G507-7410270 | AC-855029 WO-113631 | 7410270 | WASHER, hex (cover, plate screw) (for diaphragm identification only) (used w/PUMP AC-5594069) | 1 | ea |
| | | | G067-1501920 | AC-1523043 WO-116347 | A214743 | WASHER, plain, corr-res-S, 0.365 ID, 5/8 OD, 0.010 thk (rocker arm link spacer) | 2 | ea |
| 0304.1—AIR CLEANER AND CONNECTIONS | | | | | | | | |
| 03-6 | | | | UTS-B17793 | | BAND, clamp | 1 | ea |
| 03-6 | | | G758-8330127 | UTS-C17956 WO-119762 | 8330127 | BODY, half, lower, assy | 1 | ea |
| 03-6 | | | G758-8330126 | UTS-B17951 WO-119760 | 8330126 | CAP, top, assy | 1 | ea |
| | | | G758-8330124 | UTS-B17795 WO-119757 | 8330124 | CLAMP, assy | 1 | ea |
| | | | | UTS-B17793 UTS-A1453 UTS-A9896 UTS-A9894 | | Composed of: 1 BAND 1 NUT 1 STUD 1 WASHER | | |
| | H6 | | H006-0502911 | | 502911 | CLAMP, hose, S, cd- or zn-pltd, 3/4 in. (rocker arm and oil filler hoses) (superseded by CLAMP 8330945) (used on vehicles through serial No. 11389) | 4 | ea |
| 03-6 | H6 | | H006-0502922 | | 502922 | CLAMP, hose, S, cd- or zn-pltd, 2 1/4 ID (supersedes CLAMP 7036575) | 2 | ea |
| 01-15 | H6 | | H106-0116574 | | 116574 | CLAMP, hose, S, rustproof, 2 5/8 in. (air intake pipe to carburetor hose) | 2 | ea |
| | | 4730-360-8282 | G503-7036575 | WO-635097 | 7036575 | CLAMP, hose, 2 5/8 ID (air cleaner to air intake pipe) (superseded by CLAMP 502922) | 2 | ea |
| 01-15; 03-8 | H4 | | H004-8330945 | | 8330945 | CLAMP, hose (Tinnerman), S, phos-ctd, 1 3/16 ID (rocker arm and oil filler hoses) (supersedes CLAMP 502911) (used on vehicles after serial No. 11389) | 4 | ea |
| 03-6 | | | G758-8329642 | UTS-T070D17775 | 8329642 | CLEANER, oil bath, assy | 1 | ea |
| | H1 | | H101-9409097 | | 9409097 | BOLT, MACHINE, assembled washer, hex-hd, split lock washer, header-pt, S, cd- or zn-pltd, 5/16-18UNC-2A x 5/8 (air cleaner and bracket to dash) | 4 | ea |
| 03-6 | | 2940-360-8284 | G503-7327479 | OKS-613306 WO-A5631 | 7327479 | CUP, oil (optional w/CUP 8330129) | 1 | ea |

| | | | | | | | |
|----------------|----|--------------|-------------------------|---------|--|---|----|
| | | G758-8330129 | UTS-B17915 WO-119765 | 8330129 | CUP, oil, w/HANDLE, assy (optional w/CUP 7327479) | 1 | ea |
| | | G758-8330128 | UTS-B17785 WO-119764 | 8330128 | ELEMENT, filter, assy (optional w/ELEMENT OKS-613387) | 1 | ea |
| 03-6 | | G503-0169093 | OKS-613387 WO-A5630 | | ELEMENT, filter, assy (optional w/ELEMENT 8330128) | 1 | ea |
| 03-6 | | | UTS-A17779 WO-119763 | | GASKET (included in BODY 8330127) | 1 | ea |
| 03-6 | | | UTS-A17778 WO-119759 | | GASKET (included in RETAINER 8330125) | 1 | ea |
| 03-6 | | | UTS-A17781 WO-119761 | | GASKET, "O" ring (included in CAP 8330126) | 1 | ea |
| | | | WO-809083 | | HOSE, air intake pipe to oil filler tube, 1/2 ID, 0.082 OD, 6 lg (used on vehicles after serial No. 23359 and through serial No. 47032) | 1 | ea |
| 01-15 | | G758-8329646 | WO-806441 | 8329646 | HOSE, air, rubber, 2.33 ID, 2.67 OD, 0.17 thk, 1.56 lg (carburetor to air intake pipe) | 1 | ea |
| 01-15; 03-8 | | G758-8332675 | WO-810491 | 8332675 | HOSE, ventilation, ru, braided, SAE 20 R 4, 5 1/4 lg, shaped (rocker arm cover to oil filler tube (1), air intake pipe to oil filler tube (1)) (used on vehicles after serial No. 47032) | 2 | ea |
| | | G758-8329643 | WO-806357 | 8329643 | HOSE, ventilation, rubber, 0.500 ID 0.780 OD, 4.250 lg (air intake pipe to filler tube) (use 4.250 in. TUBING 33-T-240) (used on vehicles through serial No. 23359) | 1 | ea |
| | | G758-8329644 | WO-807400 | 8329644 | HOSE, ventilation, rubber, 0.500 ID, 0.780 OD, 5.500 lg (rocker arm cover to oil filler tube) (use 5.500 in TUBING 33-T-240) | 1 | ea |
| 03-6 | | | UTS-A1453 | | NUT, sp, sq, 1/4-20NC (clamp) | 1 | ea |
| | H6 | 010-3865 | H006-0283566 | 103865 | PLUG, PIPE, sq-hd, CI, 1/8 in. (optional w/PLUG 103877) (air cleaner to dash elbow tube (1), (used on vehicles after serial No. 29295) (air cleaner for fuel tank vent tube (1), (used on vehicles after serial No. 23359) | 2 | ea |
| | H6 | 010-3877 | H006-0283956 | 103877 | PLUG, PIPE, sq-hd, S, 1/8 in. (optional w/PLUG 103865) (air cleaner to dash elbow tube (1) used on vehicles after serial No. 29295) (air cleaner for fuel tank vent tube (1) used on vehicles after serial No. 23359) | 2 | ea |
| 03-6 | | G758-8329647 | WO-806451 | 8329647 | PRECLEANER, air, w/rain DEFLECTOR, assy | 1 | ea |
| 03-6 | | G758-8330125 | UTS-C17961 WO-119758 | 8330125 | RETAINER, w/GASKET, assy | 1 | ea |

0304.1

86

| (1) ILLUSTRATION NO. | (2) REFER- ENCE SYMBOLS | (3) FEDERAL STOCK NO. | (4) ORDNANCE STOCK NO. | (5) MFR'S PART NO. | (6) ORDNANCE PART NO. | (7) DESCRIPTION | (8) QUANTITY INCOR- PORATED IN UNIT | (9) UNIT OF ISSUE |
|---|----------------------------------|-----------------------------|------------------------------|--------------------------------------|-----------------------------|---|---|----------------------------|
| GROUP 03—FUEL SYSTEM—Continued | | | | | | | | |
| 0304.1—AIR CLEANER AND CONNECTIONS | | | | | | | | |
| —Continued | | | | | | | | |
| | H1 | 018-7979 | G758-8329648 H101-0187979 | WO-806185 | 8329648 187979 | SHIELD, splash generator regulator (M38A1)..... | 1 | ea |
| | H1 | 5305-017-2427 | H101-0172427 | | 172427 | BOLT, INTEGRAL, ext-teeth-lock washer, hex-hd, S, cd- or zn-pltd, ¼-20NC-2 x ¾ (generator regula- tor to shield to frame—subgroup 0602) | 1 | ea |
| | H1 | 5310-012-0386 | H001-7045531 | | 448445 | SCREW, TAPPING, THREAD CUTTING, hex-hd, fluted-taper-pt, S, cd- or zn-pltd, ¼-20NC-2 x ½ (optional w/SCREW 448445) | 1 | ea |
| | H1 | 5310-012-0386 | H001-7045531 | | 120386 | SCREW, tapping, hex-hd, S, cd- or zn-pltd, ¼-20NC-2 x ½ (optional w/SCREW 172427) | 1 | ea |
| | H1 | 5305-017-2427 | H101-0172427 | WO-809885 | 172427 | WASHER, FLAT, S, cd- or zn-pltd, ⅝ ID, ¾ OD, 0.065 thk | 1 | ea |
| | H1 | 5310-012-0386 | H001-7045531 | | 448445 | SHIELD, splash (welded) air cleaner (M170)..... | 3 | ea |
| | H1 | 5310-012-0386 | H001-7045531 | | 120386 | SCREW, TAPPING, THREAD CUTTING, hex-hd, fluted taper-pt, S, cd- or zn-pltd, ¼-20NC-2 x ½ (optional w/SCREW 448445) | 1 | ea |
| | H1 | 5310-012-0386 | H001-7045531 | | 120386 | SCREW, tapping, hex-hd, S, cd- or zn-pltd, ¼-20NC-2 x ½ (optional w/SCREW 172427) | 3 | ea |
| 03-6 | H7 | | | UTS-A9896 | | WASHER, FLAT, plain, S, cd- or zn-pltd, ⅝ ID, ¾ OD, 0.065 thk (splash shield to frame) | 1 | ea |
| 03-6 | | | H007-0220060 | | 33-T-240 | STUD, eye, sp, S, ¼-20NC (1½) x 3⅝ (clamp)..... | 1 | ft |
| | | | | UTS-A9894 | | TUBING, ru, compounded, heavy wall, ½ ID, ⅛ wall thk | 1 | ea |
| | | | | | | WASHER, sp, sq, S, 1¼ ID, ⅝ OD, 0.0375 thk (clamp). | | |
| 0304.5—UNDERWATER VENT SYSTEM | | | | | | | | |
| 01-16 | | | | AC-1543013 WO-120087 WO-806449 | | BODY, metering valve, vent, crankcase..... | 1 | ea |
| | H1 | | H101-9409110 | | 8677432 | BRACKET, support, lower (vent dual control conduit) (used on vehicles through serial No. 23359) | 1 | ea |
| 01-16 | H6 | | H006-0210030 | | 9409110 | BOLT, assembled washer, hex-hd, split lock washer, S, cd- or zn-pltd, ⅜-16UNC-2A x ⅝ | 1 | ea |
| | | | G758-8329641 | WO-800978 | 144035 | BUSHING, pipe, shoulder, MI, glvd, ¼ x ⅛ (nipple to crankcase shut off valve) | 1 | ea |
| 03-6 | H6 | | H006-0502925 | | 8329641 | CLAMP, hose, 3⅝ ID (precleaner to air cleaner) (super- seded by CLAMP 502925) | 1 | ea |
| | | | | | 502925 | CLAMP, hose, S, cd- or zn-pltd, 3 ID (supersedes CLAMP 8329641) | 1 | ea |

| | | | | | | | | |
|-------|----|---------------|--------------|---------------------------|---------------|---|---|----|
| 01-15 | | | | WO-11386 | 8393078 | CLIP, closed, S, cd- or zn-pltd, $1\frac{3}{64}$ hole for No. 10 screw (dual control conduit to bracket) (used on vehicles through serial No. 23359) | 1 | ea |
| 01-15 | H1 | 012-0361 | H001-4135661 | | 120361 | NUT, mach screw, hex, S, cd- or zn-pltd, No. 10 (0.190)-24NC-2 | 1 | ea |
| 01-15 | H1 | | H101-0454783 | | 454783 | SCREW, assembled washer, cross-recess-pan-hd, int-teeth lockwasher, header-pt, S, cd- or zn-pltd, No. 10 (0.190)-24NC-2A x $\frac{1}{2}$ | 1 | ea |
| | H4 | | H004-0327696 | | 120522 | CLIP, closed, S, cd- or zn-pltd, $\frac{5}{16}$ OD tube, hole for $\frac{1}{4}$ bolt (distributor vent tube to tee) | 1 | ea |
| | H1 | | H101-9409106 | | 9409106 | BOLT, MACHINE, assembled washer, hex-hd, split lock washer, S, cd- or zn-pltd, $\frac{1}{4}$ -20UNC-2 x $\frac{1}{2}$ | 1 | ea |
| | H4 | | H104-0192107 | | 192107 | CLIP, closed, S, cd- or zn-pltd, $\frac{5}{16}$ OD tube, hole for $\frac{5}{16}$ bolt (crankcase vent tube to water pump) | 1 | ea |
| | | 5340-704-7998 | G740-7047998 | WO-A5449 | 7047998 | CLIP, open, $\frac{5}{16}$ dia, hole for No. 10 screw (tee to union vent tube to dash (1), master cylinder vent tube to dash (1), used on vehicles through serial No. 29295) (fuel tank elbow to vent tube to dash (1), used on vehicles through serial No. 23359) | 3 | ea |
| | H1 | | H101-0454783 | | 454783 | SCREW, assembled washer, cross-recess-pan-hd, int-teeth lock washer, header-pt, S, cd- or zn-pltd, No. 10 (0.190)-24NC-2A x $\frac{1}{2}$ | 2 | ea |
| | H2 | | H002-8329624 | | 8329624 | CLIP, open, S-type, S, cd- or zn-pltd, $\frac{3}{16}$ dia tubes (fuel tank fuel line to fuel tank vent line) (used on vehicles through serial No. 23359) | 4 | ea |
| | H5 | | H005-0820644 | | 17-C-18035-40 | CONDUIT, flex, non-metallic, $\frac{3}{16}$ OD (loom) | † | ft |
| 03-4 | | 2910-737-5063 | G740-7375063 | WO-800347 | 7375063 | CONNECTOR, ball check, $\frac{3}{16}$ tube (fuel pump) (used on vehicles through serial No. 23359) | 1 | ea |
| 03-6 | H6 | | H006-0214310 | | 137404 | CONNECTOR, flared tube, inverted, br, $\frac{3}{16}$ tube, $\frac{1}{8}$ male pipe end (optional w/CONNECTOR 148072) (air cleaner to dash elbow tube (1) used on vehicles through serial No. 29295) (in air cleaner for fuel tank vent tube (1) used on vehicles through serial No. 23359) | 2 | ea |
| | | | G740-7348568 | WH-100-23123 WH-802665 | 7348568 | CONNECTOR, flared tube, inverted, br, $\frac{3}{16}$ in. (distributor vent tube to tee) | 1 | ea |
| | H6 | | H006-0214522 | | 148072 | CONNECTOR, flared tube, inverted, S, cd- or zn-pltd, $\frac{3}{16}$ tube, $\frac{1}{8}$ male pipe end (optional w/CONNECTOR 137404) (air cleaner to dash elbow tube (1) used on vehicles through serial No. 29295) (in air cleaner for fuel tank vent tube (1) used on vehicles through serial No. 23359) | 2 | ea |
| 18-6 | | | G758-8329636 | WO-806445 | 8329636 | CONTROL, dual, ventilation, assy (used on vehicles through serial No. 23359) | 1 | ea |
| | | 5310-703-2607 | G740-7032607 | WO-801085 | 7032607 | NUT, hex, S, cd- or zn-pltd, $\frac{5}{8}$ -18NF | 1 | ea |
| | | 5310-703-2605 | G740-7032605 | WO-801084 | 7032605 | WASHER, lock, ext-teeth, S, cd- or zn-pltd, $\frac{5}{8}$ in. | 1 | ea |

| (1) ILLUSTRATION NO. | (2) REFERENCE SYMBOLS | (3) FEDERAL STOCK NO. | (4) ORDNANCE STOCK NO. | (5) MFR'S PART NO. | (6) ORDNANCE PART NO. | (7) DESCRIPTION | (8) QUANTITY INCORPORATED IN UNIT | (9) UNIT OF ISSUE |
|--|--------------------------|--------------------------|---------------------------|---------------------------|--------------------------|--|--------------------------------------|----------------------|
| GROUP 03—FUEL SYSTEM—Continued | | | | | | | | |
| 0304.5—UNDERWATER VENT SYSTEM—Continued | | | | | | | | |
| 03-8 | | 4730-737-5128 | G740-7375128 | WO-801081 | 7375128 | COUPLING, transfer case air vent line (used on vehicles through serial No. 23359) | 1 | ea |
| 03-8 | H6 | | H006-0260846 | | 137420 | ELBOW, flared tube, inverted, 90 deg, br, $\frac{3}{16}$ tube, $\frac{1}{8}$ male pipe end (transfer case vent coupling (1) used on vehicles through serial No. 23359) (master cylinder to vent tube (1) used on vehicles through serial No. 29295) (distributor vent tube to tee (1)) | 3 | ea |
| 03-8 | H6 | | H006-0325200 | | 325200 | ELBOW, flared tube, inverted, stght, 90 deg, br, $\frac{3}{16}$ in. (at dash panel (1) used on vehicles through serial No. 29295), (fuel tank line and air cleaner line (1) used on vehicles through serial No. 23359) | 2 | ea |
| 01-15; 03-8 | | | | WH-103-40004 WO-807711 | 8677538 | ELBOW, pipe, automotive, street, 90 deg, extruded br or S, cd- or zn-pltd, $\frac{1}{4}$ male pipe end (vent line) (used on vehicles through serial No. 23359) | 1 | ea |
| 01-16; 03-8 | | | G758-8329637 | WO-807430 | 8329637 | ELBOW, pipe, reducing, 90 deg, S, cd- or zn-pltd, $\frac{1}{4}$ x $\frac{1}{8}$ (vent valve to vacuum tube tee) | 1 | ea |
| 03-6 | | | G758-8329645 | WO-806186 | 8329645 | HOSE, flexible (air intake) (air cleaner to air intake pipe) | 1 | ea |
| 01-15; 01-16 | | | | ANB-8X3 | | LEVER, crankcase ventilation valve | 1 | ea |
| 03-8 | | | | WO-806446 | 8677619 | LINE, air cleaner to elbow assy (at dash) (used on vehicles through serial No. 29295) Composed of: 142431 2 NUT 44-T-5080-10 1 TUBE (22 $\frac{1}{2}$ in. lg) | 1 | ea |
| 03-8 | | | | WO-807810 | | LINE, air cleaner to fuel tank elbow, assy Composed of: 17-C-18035-40 5 CONDUIT (1 in. lg) 17-C-18035-40 1 CONDUIT (3 in. lg) 137396 2 NUT 44-T-5319-55 1 TUBE (86 in. lg) | 1 | ea |
| 03-8 | | | G758-8329638 | WO-807495 | 8329638 | LINE, bell housing tee to transfer case elbow, assy (pressure) (use on vehicles through serial No. 23359) Composed of: | 1 | ea |

| | | | | | | | |
|----------------|--|--|-----------|--|--|---|----|
| 01-15; 03-8 | | | WO-806447 | 17-C-18035 -40 137396 44-T-5319- 55 8677523 | 1 CONDUIT (6 in. lg) 2 NUT 1 TUBE (23 $\frac{1}{8}$ in. lg) LINE, carburetor ventilator, assy..... | 1 | ea |
| | | | | 142431 44-T-5080- 10 | Composed of: 2 NUT 1 TUBE (9 $\frac{1}{16}$ in. lg) | | |
| 01-15; 03-8 | | | WO-806419 | 8673356 | LINE, distributor to air cleaner tube, assy..... | 1 | ea |
| | | | | 142431 44-T-5080- 10 | Composed of: 2 NUT 1 TUBING (13 in. lg) | | |
| 03-8 | | | WO-806420 | 8673357 | LINE, distributor to vacuum line tee, assy..... | 1 | ea |
| | | | | 142431 44-T-5080- 10 | Composed of: 2 NUT 1 TUBE (26 in. lg) | | |
| 03-8 | | | WO-A12935 | 8677028 | LINE, elbow to union, assy*(at dash) (used on vehicles through serial No. 29295) | 1 | ea |
| | | | | 142431 44-T-5080- 10 | Composed of: 2 NUT 1 TUBE (16 $\frac{1}{2}$ in. lg) | | |
| 03-8 | | | WO-807811 | | LINE, fuel tank to elbow, assy (at tank) (used on vehicles through serial No. 22336) | 1 | ea |
| | | | | 17-C-18035 -40 17-C-18035 -40 137396 44-T-5319- 55 | Composed of: 1 CONDUIT (18 in. lg) 1 CONDUIT (7 $\frac{1}{4}$ in. lg) 2 NUT 1 TUBE (31 in. lg) | | |
| | | | WO-808926 | | LINE, fuel tank to elbow, assy (at tank) (used on vehicles after serial No. 22336 and through serial No. 23359) | 1 | ea |
| | | | | 142431 17-C-18035 -40 17-C-18035 -40 44-T-5080- 10 | Composed of: 2 NUT 1 CONDUIT (16 $\frac{7}{8}$ in. lg) 1 CONDUIT (7 $\frac{3}{4}$ in. lg) 1 TUBE (30 $\frac{3}{4}$ in. lg) | | |

0304.5

90

| (1) ILLUSTRATION NO. | (2) REFERENCE SYMBOLS | (3) FEDERAL STOCK NO. | (4) ORDNANCE STOCK NO. | (5) MFR'S PART NO. | (6) ORDNANCE PART NO. | (7) DESCRIPTION | (8) QUANTITY INCORPORATED IN UNIT | (9) UNIT OF ISSUE |
|--|--------------------------|--------------------------|---------------------------|-----------------------|--------------------------|---|--------------------------------------|----------------------|
| GROUP 03—FUEL SYSTEM—Continued | | | | | | | | |
| 0304.5—UNDERWATER VENT SYSTEM—Continued | | | | | | | | |
| 03-8 | | | | WO-806428 | | LINE, master cylinder to union, assy (at dash) (used on vehicles through serial No. 29295) Composed of: 142431 44-T-5080-10 2 NUT 1 TUBE (29 in. lg) | 1 | ea |
| 03-8 | | | G758-8329640 | WO-807700 | 8329640 | LINE, vacuum pump to bell housing tee, assy (pressure) (used on vehicles through serial No. 23359) Composed of: 137396 44-T-5319-55 2 NUT 1 TUBE (27½ in. lg) | 1 | ea |
| 03-8 | | | G758-8329606 | WO-806064 | 8329606 | LINE, vacuum pump to crankcase vent tee, assy..... Composed of: 137398 44-T-5319-65 2 NUT 1 TUBE (16 in. lg) | 1 | ea |
| 03-8 | | | G758-8329639 | WO-806359 | 8329639 | LINE, vent, crankcase, assy (vent valve tee to manifold tee) Composed of: 137398 44-T-5319-65 2 NUT 1 TUBE (23 in. lg) | 1 | ea |
| | | | | WO-A17445 | | LOOM, split, ¾ ID, 1 in. lg (tube clip at dash (1), pressure tube at valve cover (1) (distributor vent tube to cylinder block rear (1)) (used on vehicles through serial No. 29295) | 3 | ea |
| 01-15 | | 4730-492-5042 | G740-7047970 | WO-A17122 | 7047970 | NIPPLE, hose, ¼ std taper pipe thd, 1 lg (vent valve hose connection (1) crankcase vent valve (1)) (used on vehicles through serial No. 23359) | 2 | ea |
| 01-16 | H6 | | H006-0229209 | | 192032 | NIPPLE, pipe, std, cd- or zn-pltd, ⅝ x ¼ (close) (crankcase vent shut-off valve to valve spring cover reducer) | 1 | ea |
| 01-16 | H6 | 4730-019-2050 | H006-0229219 | | 192050 | NIPPLE, pipe, S, std, cd- or zn-pltd, ¼ x ⅜ (close) (vent valve to shut-off valve) | 1 | ea |
| 01-15, 16 | | | | ANB-3X11 | | NUT, crankcase ventilation valve..... | 1 | ea |

| | | | | | | | | |
|------------|----|---------------|--------------|--------------------------------------|--------------|---|----|----|
| 03-8 | H6 | 014-2431 | H006-0230209 | | 142431 | NUT, inverted flared tube fitting, br, $\frac{5}{16}$ in. (used on vehicles through serial No. 22336 (20) through serial No. 23359 (14), through serial No. 29295 (12), after serial No. 29295 (6)) | 20 | ea |
| | H6 | 014-2427 | H006-0230208 | | 142427 | NUT, inverted, flared tube fitting, br, $\frac{5}{16}$ in. (optional w/NUT 137398) | 4 | ea |
| | H6 | | H006-0230308 | | 137396 | NUT, inverted flared tube fitting, S, cd- or zn-pltd, $\frac{5}{16}$ in. (used on vehicles through serial No. 22336 (2), through serial No. 23359 (6)) | 6 | ea |
| | H6 | | H006-0230311 | | 137398 | NUT, inverted, flared tube fitting, S, cd- or zn-pltd, $\frac{5}{16}$ in. (optional w/NUT 142427) | 4 | ea |
| 01-15, 16 | H1 | | H101-0119981 | | 119981 | PIN, cotter, split, S, pltd, $\frac{1}{16}$ x $\frac{3}{8}$ (crankcase ventilation valve) (used on vehicles through serial No. 23359) | 2 | ea |
| 01-15, 16 | | 2805-737-2554 | G740-7372554 | WO-A17842 | 7372554 | PIN, SWIVEL, control wire (crankcase ventilation, valve) (used on vehicles through serial No. 23359) | 2 | ea |
| 01-15 | | | | WO-806433 | 8677521 | PIPE, air intake, w/BRACKET (used on vehicles through serial No. 23359) | 1 | ea |
| 01-2, 3, 4 | | | G758-8332084 | WO-809246 | 8332084 | PIPE, air intake, w/BRACKET and CLIP, assy (used on vehicles after serial No. 23359) | 1 | ea |
| | | | G758-8329634 | WO-806435 | 8329634 | PIPE, air intake, w/vent VALVE and BRACKET, assy (used on vehicles through serial No. 23359) | 1 | ea |
| 01-16 | | | G749-6246309 | AC-1542836 WO-120090 WO-648452 | B246309 | RETAINER, valve, metering, vent, crankcase..... | 1 | ea |
| 01-15, 16 | H1 | 013-2684 | H101-0132684 | | 132684 | RING, ru, $\frac{1}{8}$ ID, $1\frac{1}{8}$ OD, $\frac{3}{8}$ dia thk (air intake support) | 1 | ea |
| 01-15, 16 | H1 | 5310-012-0391 | H001-7043621 | | 120391 | SCREW, mach, rd-hd, S, cd- or zn-pltd, No. 6-32NC-2 x $\frac{3}{16}$ (crankcase ventilation valve) (used on vehicles through serial No. 23359) | 2 | ea |
| 01-16 | | | G749-5291787 | AC-1542947 WO-120089 | 5291787 | WASHER, FLAT, plain, S, cd- or zn-pltd, $\frac{1}{32}$ ID, $\frac{1}{2}$ OD, 0.049 thk | 2 | ea |
| | H6 | | H006-0235820 | | 143483 | SPRING, metering valve, vent, crankcase..... | 1 | ea |
| | H7 | | H007-0218040 | | 44-T-5080-10 | TEE, flared tube, inverted, br, $\frac{5}{16}$ tube, $\frac{1}{8}$ male pipe side (vent tube to reducing elbow) | 1 | ea |
| | H7 | | H007-0881850 | | 44-T-5319-55 | TUBING, cop, seamless, soft annealed, size $\frac{3}{15}$ in., OD 0.188 in., thickness of wall 0.035 in. | ‡ | ft |
| | H7 | | H007-0881856 | | 44-T-5319-65 | TUBING, S, cold drawn, rd, $\frac{3}{16}$ OD, 0.028 wall thk..... | ‡ | ft |
| 03-8 | H6 | | H006-0391110 | | 137412 | TUBING, S, cold drawn, rd, $\frac{5}{16}$ OD, 0.028 wall thk..... | ‡ | ft |
| 03-8 | | 2910-741-0836 | G740-7410836 | ANB-SK971 WO-804277 | 7410836 | UNION, flared tube, inverted, br, $\frac{3}{16}$ in (at dash) (used on vehicles through serial No. 29295) | 1 | ea |
| 03-8, 9 | | | G741-8332556 | EAT-IE2322 WO-807166 | 8332556 | VALVE, control, w/PIN, assy (used on vehicles through serial No. 23359) | 2 | ea |
| 03-9 | H1 | 5305-015-9592 | H101-0159592 | | 159592 | VALVE, fuel tank..... | 1 | ea |
| | | | | | | SCREW, mach, cross-recess-pan-hd, S, cd- or zn-pltd, No. 8-32NC-2 x $\frac{1}{2}$ | 6 | ea |

0304.5

92

| (1) | (2) | (3) | (4) | (5) | (6) | (7) | (8) | (9) |
|------------------|-------------------|-------------------|--------------------|---|-------------------|---|-------------------------------|---------------|
| ILLUSTRATION NO. | REFERENCE SYMBOLS | FEDERAL STOCK NO. | ORDNANCE STOCK NO. | MFR'S PART NO. | ORDNANCE PART NO. | DESCRIPTION | QUANTITY INCORPORATED IN UNIT | UNIT OF ISSUE |
| | | | | | | GROUP 03—FUEL SYSTEM—Continued | | |
| | | | | | | 0304.5—UNDERWATER VENT SYSTEM—Continued | | |
| 01-16 | | | | AC-1542837 WO-120088 | A291788 | VALVE, metering, vent, crankcase..... | 1 | ea |
| 01-16; 03-8 | | 2940-360-7930 | G740-5336400 | AC-1543018 WO-A6895 | 5336400 | VALVE, metering, vent, crankcase, assy..... | 1 | ea |
| 01-15, 16 | | 4820-737-2752 | G742-7372752 | ANB-SK950 WO-804276 | 7372752 | VALVE, shut-off, crankcase ventilation, assy (used on vehicles through serial No. 23359) (use HOSE 8332085 after serial No. 23359, subgroup 0106.5) | 2 | ea |
| 01-15, 16 | | | | ANB-2X62 | | WASHER, crankcase ventilation valve..... | 1 | ea |
| | | | | | | 0306—FUEL TANK AND LINES | | |
| 03-9 | | | G758-8329614 | WO-807331 | 8329614 | ANTI-SQUEAK, fuel tank (1 wide x 3 1/2 lg) (M38A1)..... | 2 | ea |
| 03-9 | | | G758-8329615 | WO-807330 | 8329615 | ANTI-SQUEAK, fuel tank (1 wide x 12 lg) (M38A1)..... | 2 | ea |
| 03-9 | | 2910-737-5012 | G740-7375012 | WO-801561 | 7375012 | ANTI-SQUEAK, fuel tank (1 wide x 18 1/16 lg) (M38A1)..... | 2 | ea |
| 03-9 | | | G758-8329613 | WO-801562 | 8329613 | ANTI-SQUEAK, fuel tank (1 wide x 23 7/16 lg) (M38A1)..... | 1 | ea |
| 03-10 | | | | ACK-314-47 WO-809126 | | ANTI-SQUEAK, fuel tank (1 wide x 15 1/4 lg) (M170)..... | 4 | ea |
| 03-10 | | | | WO-811418 | | ANTI-SQUEAK, fuel tank (1 3/4 wide x 37 lg) (M170)..... | 2 | ea |
| | | | G758-8329616 | EAT-IE2387 WO-806663 STN-AAB1917 WO-806664 | 8329616 | CAP, filler, fuel tank, assy (includes CHAIN and CLIP) (superseded by CAP 8333722) | 1 | ea |
| 03-9, 11 | | | G744-8333722 | EAT-CD2616 WO-905745 STN-12085A WO-905744 WO-807355 | 8333722 | CAP, filler, fuel tank, assy (supersedes CAP 8329616) (includes CHAIN and CLIP) (use after engine serial No. 12120 and through engine serial No. 23359) | 1 | ea |
| | | | | WO-801266 | | CHAIN, fuel tank cap, assy, (riveted) (includes CLIPS) (used w/CAP 8329616 and 8333722) | 1 | ea |
| | | | | WO-801266 | | CHAIN, fuel tank cap, assy (includes CLIP) (riveted) (used w/CAP 8329616 and 8333722) | 1 | ea |
| | | | | STN-CHX100 | | CHAIN, fuel tank cap, S, zn-pltd, 2 in. lg (used w/CAP 8329616) | 1 | ea |
| | | | | STN-CHX200 | | CHAIN, fuel tank cap, S, zn-pltd, approx 2.31 lg (used w/CAP 8333722) | 1 | ea |
| | H4 | | H004-0327721 | | 120524 | CLIP, closed, S, cd- or zn-pltd, 7/16 OD tube, hole for 1/4 bolt (fuel line to front floor riser) (M170) | 1 | ea |
| | H1 | 012-0854 | H001-5417601 | | 120854 | BOLT, mach, hex-hd, S, cd- or zn-pltd, 1/4-20NC-3 x 5/8 | 1 | ea |

| | | | | | | | | |
|----------|----|---------------|------------------------------|------------------------|------------------------|--|---|----|
| | H1 | | H101-0271172 | | 271172 | NUT, hex, w/ext-teeth lock washer, Keps type, 1/4-20NC-2 | 1 | ea |
| | | | STN-CCX030 | | | CLIP, fuel tank cap, snap, zn-pltd (used w/CAP 8329616 and 8333722) | 2 | ea |
| | | | G758-8329783 | WO-648591 | 8329783 | CLIP, push on type 5/16 in. (left intermediate reinforcement (1), front crossmember (2), front floor diagonal brace (1), front floor riser (1), right frame reinforcement (1), fuel line to frame bracket (1)) (superseded by CLIP 127753) | 7 | ea |
| 03-11 | | | | | 127753 | CLIP, push on type, 5/16 in. (left intermediate reinforcement (1), front crossmember (2), front floor diagonal brace (1), front floor riser (1), right frame reinforcement (1), fuel line to frame bracket (1)) (supersedes CLIP 8329783) | 7 | ea |
| | H6 | | H006-0260846 | | 137420 | ELBOW, flared tube, inverted, 90 deg, br, 3/16 tube, 1/8 male pipe end (carburetor vent) (optional w/ELBOW 189954) | 1 | ea |
| 03-5 | H6 | | H006-0260807 | | 137421 | ELBOW, flared tube, inverted, 90 deg, br, 1/4 tube, 1/8 male pipe end (fuel pump) (vacuum section) | 1 | ea |
| 03-3, 5 | H6 | | H006-0260850 | | 137422 | ELBOW, flared tube, inverted, 90 deg, br, 5/16 tube, 1/8 male pipe end (fuel pump) (fuel section (2), vacuum section (1)) | 3 | ea |
| | H6 | | H006-0260933 | | 189954 | ELBOW, flared tube, inverted, 90 deg, S, cd- or zn-pltd, 3/16 tube, 1/8 male pipe end (carburetor vent) (optional w/ELBOW 137420) | 1 | ea |
| 03-4 | H6 | 044-4038 | H106-0444038 | | 444038 | ELBOW, pipe, automotive, street, 90 deg, extruded, br, 1/8 in. (fuel pump) (vacuum section) (used on vehicles through serial No. 23359) | 1 | ea |
| 03-11 | H6 | | H006-0325210 | | | ELBOW, flared tube, inverted, stght, 90 deg, br, 5/16 in. (fuel line tube to tube fitting) | 1 | ea |
| 03-9 | | 5330-737-5020 | G740-7375020 | EAT-1237 WO-801263 | 7375020 | GASKET, ru, fuel tank cap, 3.530 ID, 4.3125 OD, 0.125 thk | 1 | ea |
| 03-9, 11 | | 5325-737-5036 | G740-7375036 G758-8329618 | WO-673415 WO-806065 | 7375036 8329618 | GROMMET, fuel tank filler neck | 1 | ea |
| | | | | | | LINE, carburetor to fuel pump | 1 | ea |
| | | | | | | Composed of: 2 NUT 1 TUBE (40 1/2 in lg), S | | |
| | | | G758-8329778 | WO-806172 | 8329778 | LINE, flexible, fuel line to fuel pump (superseded by LINE 8331933) | 1 | ea |
| 03-11 | | | G758-8331933 | WO-808363 | 8331933 | LINE, flexible, fuel line to fuel pump (supersedes LINE 8329778) | 1 | ea |
| 03-11 | | | G758-8329775 | WO-806141 | 8329775 | LINE, fuel, elbow to tee, assy (M38A1) | | |
| | | | | | | Composed of: 2 NUT 1 TUBE (80 in. lg), S | | |
| | | | | | 142427 44-T-5080-20 | | | |

56

| | | | | | | | |
|----------|----|---------------|--------------|---------|---|--------------|----------------|
| 03-11 | | | WO-809403 | | LINE, fuel, tee to shut-off valve, assy (supersedes LINE 8329617) (used on vehicles after serial No. 60406) Composed of: 142427 2 NUT 44-T-5080-20 1 TUBE (43 1/8 in. lg), S | 1 | ea |
| | | G758-8329777 | WO-806184 | 8329777 | LINE, fuel, valve to fuel pump hose, assy (superseded by LINE WO-809404) (used on vehicles through serial No. 60406) Composed of: 142427 2 NUT 44-T-5080-20 1 TUBE (5 1/2 in. lg), S | 1 | ea |
| 03-11 | | | WO-809404 | | LINE, fuel, valve to fuel pump hose, assy (supersedes LINE 8329777) (used on vehicles after serial No. 60406) Composed of: 142427 2 NUT 44-T-5080-20 1 TUBE (3 7/8 in.), S | 1 | ea |
| | H6 | 014-2427 | H006-0230208 | 142427 | WO-906062 BY-3150-5 LOOM, auto, asphalt finish, 5/16 ID, 1 1/4 lg (rear fuel line)..... LOOM, non-metallic, 7 1/4 in. lg, 0.06 approx thk..... NUT, inverted flared tube fitting, br, 5/16 in. (optional w/NUT 137398) | 1 † 10 | ea ft ea |
| | H6 | 013-7398 | H006-0230311 | 137398 | NUT, inverted flared tube fitting, S, cd- or zn-pltd, 5/16 in. (optional w/NUT 142427) | 10 | ea |
| | | | WO-808998 | | PLUG, filtered ventilation (used on vehicles after serial No. 23359) | 1 | ea |
| 03-9 | H6 | 012-7951 | H006-0283195 | 127951 | PLUG, pipe, hex-hd, br, 1/4 in. (fuel tank drain) (optional w/PLUG WO-807134) | 1 | ea |
| | | | WO-807134 | | PLUG, pipe, hex-hd, br, 1/4 in. (fuel tank drain) (optional w/PLUG 127951) | 1 | ea |
| 03-11 | H6 | 014-3932 | H106-0143932 | 143932 | PLUG, pipe, sq-hd, CI, cd- or zn-pltd, 1/8 in. (used w/TEE 128275) | 1 | ea |
| 03-9 | | | G758-8330946 | 8330946 | SEAL, front floor pan and fuel tank drain plug (black sponge ru) (used on vehicles after serial No. 11638) | 1 | ea |
| 03-10 | | | WO-811440 | | SHIELD, fuel tank (M170) | 2 | ea |
| 03-9 | | | G758-8329781 | 8329781 | STRAINER, fuel tank filter | 1 | ea |
| 03-9, 11 | | | G758-8329782 | 8329782 | STRAP, hold-down, fuel tank (M38A1) | 1 | ea |
| 03-9, 11 | H1 | | H101-9409098 | 9409098 | BOLT, MACHINE, assembled washer, hex-hd, split lock washer, header-pt, S, cd- or zn-pltd, 5/16-18UNC-2A x 7/8 | 2 | ea |
| 03-10 | | | WO-811439 | | STRAP, hold-down fuel tank, assy (M170) | 2 | ea |
| 03-10 | | | | 442828 | NUT, SELF-LOCKING, HEX, "Huglock," S, cd- or zn-pltd, 3/8-24UNF-2B 5/16 x 1 13/32 | 4 | ea |
| 03-10 | H1 | 5310-012-0394 | H001-7043741 | 120394 | WASHER, FLAT, S, cd- or zn-pltd, 1 13/32 ID, 1 13/16 OD, 0.065 thk | 4 | ea |

9080

| (1) ILLUSTRATION NO. | (2) REFER- ENCE SYMBOLS | (3) FEDERAL STOCK NO. | (4) ORDNANCE STOCK NO. | (5) MFR'S PART NO. | (6) ORDNANCE PART NO. | (7) DESCRIPTION | (8) QUANTITY INCOR- PORATED IN UNIT | (9) UNIT OF ISSUE |
|---|----------------------------------|-----------------------------|------------------------------|------------------------|-----------------------------|---|---|----------------------------|
| GROUP 03—FUEL SYSTEM—Continued | | | | | | | | |
| 0306—FUEL TANK AND LINES—Continued | | | | | | | | |
| 03-9, 11 | | | G758-8329621 | WO-805905 | 8329621 | TANK, fuel, assy (M38A1) | 1 | ea |
| 03-10, 12 | | | G758-8333277 | WO-811417 | 8333277 | TANK, fuel, assy (M170) | 1 | ea |
| 03-11 | H6 | | H006-0235420 | | 128275 | TEE, flared tube, inverted, br, $\frac{5}{16}$ tube, $\frac{1}{8}$ female pipe side (used w/LINE 8329617 and 8329775) | 1 | ea |
| | H7 | | H007-0881856 | | 44-T-5319-65 | TUBING, S, cold drawn, rd, $\frac{5}{16}$ OD, 0.028 wall thk | ‡ | ft |
| | H7 | | H007-0218080 | | 44-T-5080-20 | TUBING, S, seamless, pltd, $\frac{5}{16}$ OD, 0.030 thk of wall | ‡ | ft |
| 03-11 | H6 | | H006-7346871 | | 7346871 | VALVE, plug, shutoff, $\frac{1}{2}$ -20NF internal thread (fuel line) | 1 | ea |
| 0309—FUEL FILTER | | | | | | | | |
| 03-9 | | 2910-735-1316 | G740-7351316 | ZP-R32-63 WO-802613 | 7351316 | ELEMENT | 1 | ea |
| 03-9 | H1 | 012-0361 | G758-8328441 H001-4135661 | WO-806626 | 8328441 120361 | FILTER, assy NUT, mach, screw, hex, S, cd- or zn-pltd, No. 10-24NC-2 | 1 1 | ea ea |
| 03-9 | H1 | | H001-5148291 | | 132844 | SCREW, mach, rd-hd, (slotted) S, cd- or zn-pltd, No. 10-24NC-2 x $\frac{7}{8}$ | 1 | ea |
| 03-9 | H1 | 5310-012-0217 | H001-7025621 | | 120217 | WASHER, lock, med, S, cd- or zn-pltd, No. 10 | 1 | ea |
| 03-9 | | | | ACK-DK149 WO-807164 | | GASKET, air vent, fuel tank | 1 | ea |
| 03-9 | | 5330-735-1315 | G740-7351315 | WO-649739 | 7351315 | GASKET, cover plate (neoprene) | 1 | ea |
| 03-9 | | | | WO-805913 | 8677508 | PLATE, cover, w/filter BRACKET, assy | 1 | ea |
| 03-11 | | | | WO-805912 | 8677507 | PLATE, cover, w/VENT, assy | 1 | ea |
| 03-9 | | | G758-8332077 | WO-808137 | 8332077 | SCREW, int-teeth-lock washer, cross-recess-pan-hd, header-pt, S, cd- or zn-pltd, No. 8-32NC-2 x $\frac{3}{8}$ | 12 | ea |
| 03-9 | | | | WO-802608 | | PLATE, end (lower) | 1 | ea |
| 03-9 | H1 | 012-0361 | H001-4135661 | | 120361 | NUT, mach screw, hex, S, cd- or zn-pltd, No. 10-24NC-2 | 1 | ea |
| 03-9 | H1 | | H001-0455268 | | 455268 | SCREW, mach, rd-hd, S, cd- or zn-pltd, No. 10-24NC-2A x 4 | 1 | ea |
| 03-9 | H1 | 5310-012-0217 | H001-7025621 | | 120217 | WASHER, lock, med, S, cd- or zn-pltd, No. 10 | 1 | ea |
| 03-9 | | | | WO-806627 | 8677525 | PLATE, end, upper, w/TUBE and NUT, assy | 1 | ea |

| | | | | | 0312—ACCELERATOR, HAND THROTTLE, AND CHOKE CONTROL | | | |
|------------|----|---------------|--------------|-----------|---|--|---|----|
| 03-7 | | | G758-8329759 | WO-805728 | 8329759 | BLOCK, adjusting, throttle rod | 1 | ea |
| 03-7 | H1 | 012-0367 | H001-4167521 | | 120367 | NUT, hex, lt, s-fin, S, cd- or zn-pltd, $\frac{1}{4}$ -28NF-2 | 2 | ea |
| | H1 | | H001-4417121 | | 112726 | PIN, cotter, split, S, cd- or zn-pltd, $\frac{1}{16}$ x $\frac{1}{2}$ (superseded by PIN 121223) | 1 | ea |
| 03-7 | H1 | | H001-4417141 | | 121223 | PIN, cotter, split, S, pltd, $\frac{1}{16}$ x $\frac{3}{4}$ (supersedes PIN 112726) | 1 | ea |
| 03-7 | H1 | 5310-012-0393 | H001-7043711 | | 120393 | WASHER, FLAT, S, cd- or zn-pltd, $1\frac{1}{32}$ ID, $1\frac{1}{16}$ OD, 0.065 thk | 1 | ea |
| 03-7 | | | G758-8329768 | WO-805479 | 8329768 | BRACKET, bellcrank | 1 | ea |
| | | | G758-8329767 | WO-805478 | 8329767 | BRACKET, bellcrank, w/LEVER and SPRING, assy | 1 | ea |
| | | | | WO-806335 | | CONDUIT, choke control, w/GUIDE, assy | 1 | ea |
| | | | | WO-806338 | | CONDUIT, throttle control, w/GUIDE, assy | 1 | ea |
| 03-7, 18-6 | | | G758-8329760 | WO-806338 | 8329760 | CONTROL, choke, assy | 1 | ea |
| 03-7 | H1 | | H101-0271193 | | 271193 | NUT, hex, lt, ext-teeth lock washer, S, cd- or zn-pltd, $\frac{3}{8}$ -24NF-2B | 1 | ea |
| 03-7, 18-6 | | | G758-8329761 | WO-806337 | 8329761 | CONTROL, throttle, assy | 1 | ea |
| 03-7 | H1 | | H101-0271193 | | 271193 | NUT, hex, lt, ext-teeth lock washer, S, cd- or zn-pltd, $\frac{3}{8}$ -24NF-2B | 1 | ea |
| | | 5325-737-5129 | G740-7375129 | WO-800804 | 7375129 | GROMMET, ru, split, $\frac{3}{16}$ in (in dash) (choke control cable (1), throttle control cable (1)) (supersedes GROMMET 120013) | 2 | ea |
| | | 3250-737-5064 | G740-7375064 | WO-800803 | 7375064 | GROMMET, ru, split, $\frac{5}{8}$ ID, $2\frac{7}{32}$ x $\frac{1}{16}$ groove dia (in dash for choke, throttle and dual controls) (superseded by GROMMET 120013) | 1 | ea |
| | H2 | | H102-0120013 | | 120013 | GROMMET, split, ru, $\frac{5}{8}$ ID, $3\frac{1}{32}$ x $\frac{1}{16}$ groove dia (supersedes GROMMET 7375064) (superseded by GROMMET 7375129) | 1 | ea |
| 03-7 | | 5340-737-5114 | G740-7375114 | WO-650482 | 7375114 | HINGE, accelerator pedal | 1 | ea |
| | | | | WO-806334 | | KNOB, choke control, w/PLUNGER and WIRE, assy | 1 | ea |
| | | | | WO-806339 | | KNOB, throttle control, w/PLUNGER and WIRE, assy | 1 | ea |
| | | | G758-8329766 | WO-806953 | 8329766 | LEVER, accelerator bell crank w/BUSHING (lower) (used on vehicles through serial No. 11097) | 1 | ea |
| 03-7 | | | G758-8330947 | WO-808333 | 8330947 | LEVER, accelerator bell crank, w/BUSHING (lower) (used on vehicles after serial No. 11097) | 1 | ea |
| 03-7 | H1 | | H001-4417141 | | 121223 | PIN, cotter, split, S, pltd, $\frac{1}{16}$ x $\frac{3}{4}$ | 1 | ea |
| 03-7 | H1 | 5310-012-0393 | H001-7043711 | | 120393 | WASHER, flat, S, cd- or zn-pltd, $1\frac{1}{32}$ ID, $1\frac{1}{16}$ OD, 0.065 thk | 2 | ea |
| 03-7 | | | G758-8329769 | WO-805480 | 8329769 | LEVER, accelerator bellcrank, w/SHAFT (upper) | 1 | ea |
| 03-7 | H1 | | H001-4417141 | | 121223 | PIN, cotter, split, S, pltd, $\frac{1}{16}$ x $\frac{3}{4}$ | 2 | ea |
| | | 5310-732-4835 | G503-7324835 | WO-51662 | 7324835 | WASHER, FLAT, S, No. 8 (superseded by WASHER 502243) | 1 | ea |
| 03-7 | H1 | | H101-0502243 | | 502243 | WASHER, FLAT, S, cd- or zn-pltd, $\frac{1}{32}$ ID, $\frac{3}{8}$ OD, 0.035 thk (supersedes WASHER 7324835) | 1 | ea |
| | H1 | 5310-012-0392 | H001-7043681 | | 120392 | WASHER, FLAT, S, cd- or zn-pltd, $\frac{9}{32}$ ID, $\frac{5}{8}$ OD, 0.065 thk | 1 | ea |

| (1) ILLUSTRATION NO. | (2) REFERENCE SYMBOLS | (3) FEDERAL STOCK NO. | (4) ORDNANCE STOCK NO. | (5) MFR'S PART NO. | (6) ORDNANCE PART NO. | (7) DESCRIPTION | (8) QUANTITY INCORPORATED IN UNIT | (9) UNIT OF ISSUE |
|--|--------------------------|--------------------------|---------------------------|------------------------|--------------------------|---|--------------------------------------|----------------------|
| GROUP 03—FUEL SYSTEM—Continued | | | | | | | | |
| 0312—ACCELERATOR HAND THROTTLE, AND CHOKE CONTROL—Continued | | | | | | | | |
| 03-7, 18-6 | | | G758-8333364 | WO-810592 WO-805545 | 8333364 8677501 | PEDAL, accelerator (supersedes PEDAL 8677501)..... | 1 | ea |
| | | | | | | PEDAL, w/HINGE and LINK, assy (superseded by PEDAL 8333364) | 1 | ea |
| 03-7 | H1 | 015-5937 | H101-0155937 | | 155937 | BOLT, MACHINE, cross-recess-fl-hd, S, cd- or zn-pltd, No. 10-24NC-2 x 1/2 | 2 | ea |
| 03-7 | H1 | | H101-0271166 | | 271166 | NUT, hex, ext-teeth lock washer, S, cd- or zn-pltd, No. 10-24NC-2A | 2 | ea |
| | | | G758-8329762 | WO-805546 | 8329762 | PEDAL, accelerator, w/LINK, assy (part of PEDAL 8677501) (superseded by PEDAL 8333364) | 1 | ea |
| 03-7 | H1 | | H001-4417141 | | 121223 | PIN, cotter, split, S, pltd, 1/16 x 3/4 | 1 | ea |
| 03-7 | | 5315-737-5112 | G740-7375112 | WO-650484 WO-803357 | 7375112 | PIN, hinge, 2 3/64 x 1/4 dia | 1 | ea |
| 03-7 | | 2540-737-5392 | G740-7375392 | WO-800783 | 7375392 | PLATE, retracting spring clip | 1 | ea |
| | | | | | | REST, foot, accelerator (superseded by BOLT 425899 listed in subgroup 1805) (used on vehicles through serial No. 34021) | 1 | ea |
| 03-7 | H1 | 012-4920 | H001-4185561 | | 124920 | NUT, jam, hex, lt, s-fin, S, cd- or zn-pltd, 3/16-24NF-2 | 1 | ea |
| 03-7 | | | G758-8329765 | WO-806952 | 8329765 | ROD, accelerator (bellcrank link) | 1 | ea |
| 03-7 | H1 | | H001-4417141 | | 121223 | PIN, cotter, split, S, pltd, 1/16 x 3/4 | 1 | ea |
| | | 5310-732-4835 | G503-7324835 | WO-51662 | 7324835 | WASHER, FLAT, S, No. 8 (superseded by WASHER 502243) | 1 | ea |
| 03-7 | H1 | | H101-0502243 | | 502243 | WASHER, FLAT, S, cd- or zn-pltd, 1/32 ID, 3/8 OD, 0.035 thk (supersedes WASHER 7324835) | 1 | ea |
| | | | | WO-805547 | 8680895 | ROD, connector, accelerator, assy (includes DISC and SOCKET) (superseded by ROD 8333365) | 1 | ea |
| 03-7 | | | | WO-805548 | 8677502 | ROD, connector, accelerator | 1 | ea |
| 03-7 | | | G758-8333365 | WO-810557 | 8333365 | ROD, connector, accelerator, assy (supersedes ROD 8680895) | 1 | ea |
| | | | | | | Composed of: | | |
| | | | | | 8329759 | 1 BLOCK | | |
| | | | | | 120367 | 1 NUT | | |
| | | | | | 8677502 | 1 ROD | | |
| 03-7 | | | G758-8329763 | WO-807176 | 8329763 | ROD, throttle (accelerator bellcrank to carburetor) | 1 | ea |
| 03-7 | H1 | | H001-4417141 | | 121223 | PIN, cotter, split, S, pltd, 1/16 x 3/4 | 2 | ea |
| | | | G503-7324835 | WO-51662 | 7324835 | WASHER, FLAT, S, No. 8 (used on vehicles through serial No. 42774) (superseded by WASHER 502243) | 2 | ea |
| 03-7 | H1 | | H101-0502243 | | 502243 | WASHER, FLAT, S, cd- or zn-pltd, 1/32 ID, 3/8 OD, 0.035 thk (supersedes WASHER 7324835) | 2 | ea |

| | | | | | | | | |
|------|----|---------------|--------------|-----------|---------|---|---|----|
| 03-7 | | 2510-736-1994 | G503-7361994 | WO-646073 | 7361994 | SEAL, floor, accelerator pedal rod..... | 1 | ea |
| 03-7 | | | G758-8329770 | WO-805483 | 8329770 | SPRING, accelerator bellcrank lever, upper (4.0 lb compression) | 1 | ea |
| | | 5340-737-1454 | G503-7371454 | WO-650483 | 7371454 | SPRING, accelerator pedal hinge (used on vehicles through serial No. 76674) | 1 | ea |
| | | | G758-8329764 | WO-806950 | 8329764 | SPRING, retracting, accelerator pedal (superseded by SPRING 8830948) | 1 | ea |
| 03-7 | | | G758-8330948 | WO-803358 | 8330948 | SPRING, retracting, accelerator pedal (supersedes SPRING 8329764) | 1 | ea |
| | H1 | 012-2159 | G503-7371193 | WO-372438 | 7371193 | STOP, throttle wire..... | 1 | ea |
| | | | H001-5147511 | | 122159 | SCREW, mach, rd-hd, S, cd- or zn-pltd, No. 8 (0.164)-32NC-2 x 1/4 | 1 | ea |
| 03-7 | | 2540-737-1194 | G503-7371194 | WO-A8834 | 7371194 | STOP, throttle wire, w/SCREW, assy..... | 1 | ea |

produced by Military Media Inc., copyright 1999

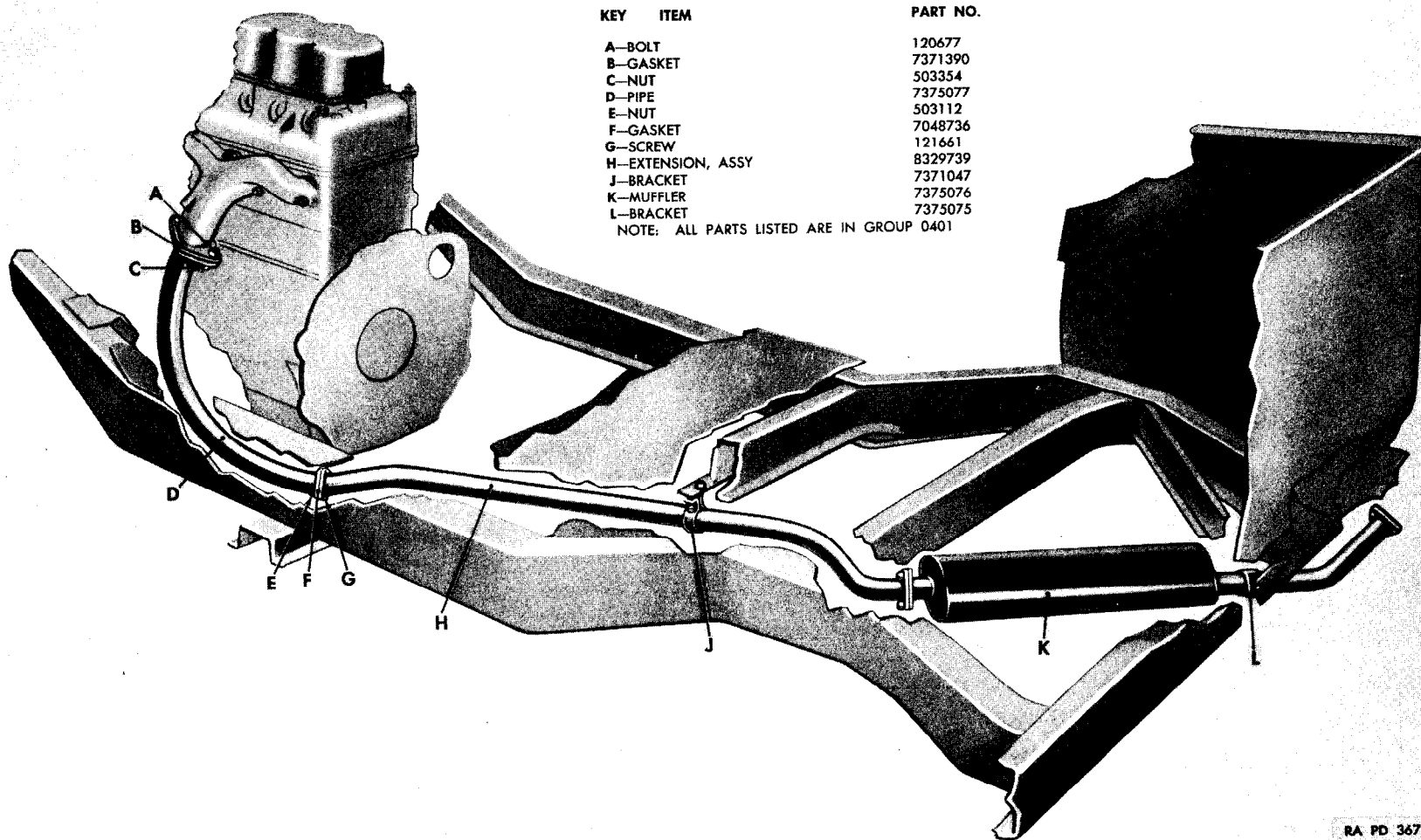

| KEY | ITEM | PART NO. |
|-----|-----------------|----------|
| A | BOLT | 120677 |
| B | GASKET | 7371390 |
| C | NUT | 503354 |
| D | PIPE | 7375077 |
| E | NUT | 503112 |
| F | GASKET | 7048736 |
| G | SCREW | 121661 |
| H | EXTENSION, ASSY | 8329739 |
| J | BRACKET | 7371047 |
| K | MUFFLER | 7375076 |
| L | BRACKET | 7375075 |

NOTE: ALL PARTS LISTED ARE IN GROUP 0401

Figure 04-1. Exhaust system

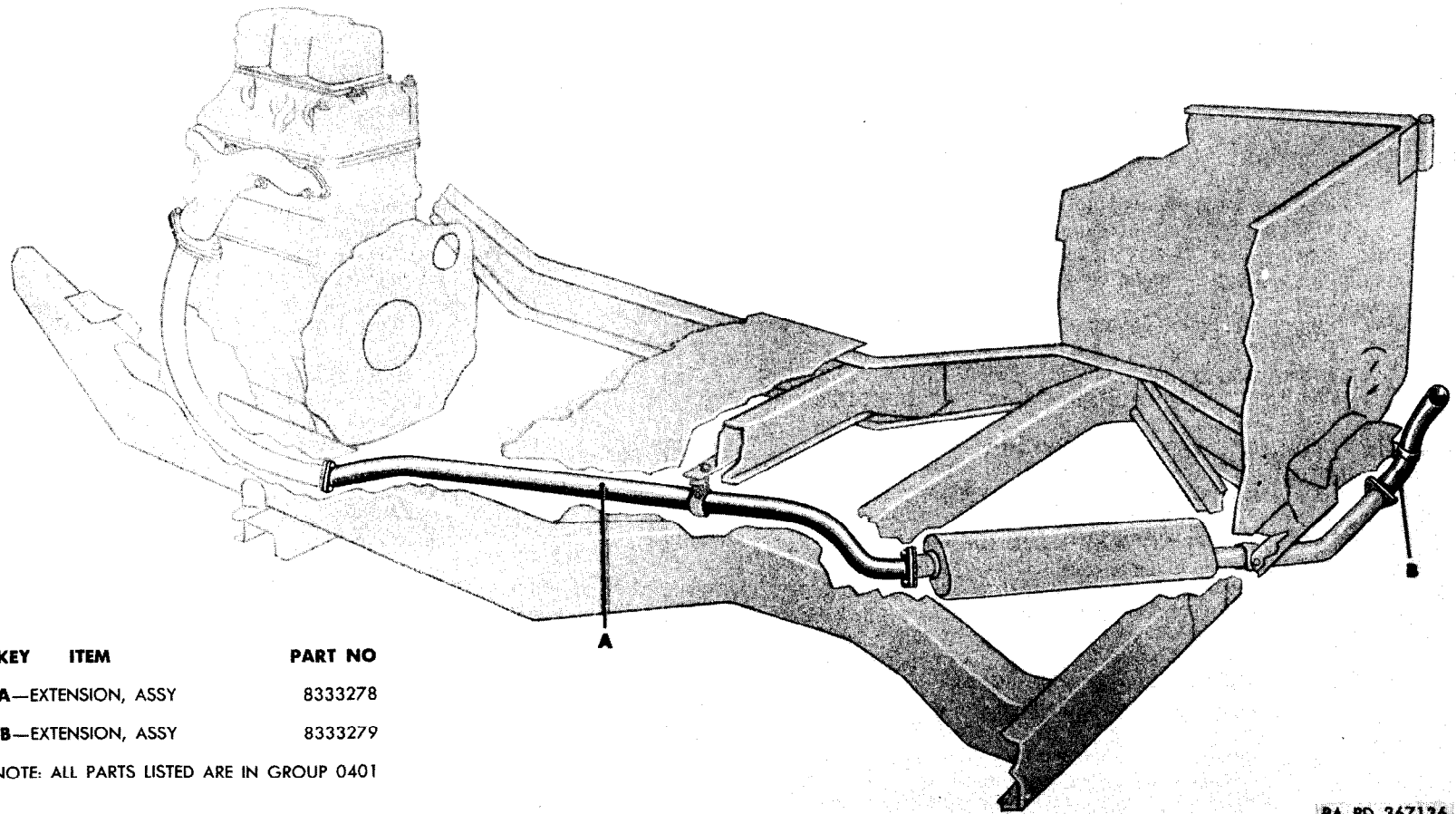

| KEY | ITEM | PART NO |
|-----|------------------|---------|
| A | —EXTENSION, ASSY | 8333278 |
| B | —EXTENSION, ASSY | 8333279 |

NOTE: ALL PARTS LISTED ARE IN GROUP 0401

RA PD 367136

Figure 04-2. Exhaust system (M170)

0401

| (1) ILLUSTRATION NO. | (2) REFER- ENCE SYMBOLS | (3) FEDERAL STOCK NO. | (4) ORDNANCE STOCK NO. | (5) MFR'S PART NO. | (6) ORDNANCE PART NO. | (7) DESCRIPTION | (8) QUANTITY INCOR- PORATED IN UNIT | (9) UNIT OF ISSUE |
|--------------------------------------|----------------------------------|-----------------------------|------------------------------|-----------------------|-----------------------------|--|---|----------------------------|
| GROUP 04—EXHAUST SYSTEM | | | | | | | | |
| 0401—MUFFLER AND EXHAUST PIPE | | | | | | | | |
| 04-1 | | 2990-737-1047 | G503-7371047 | WO-A15498 | 7371047 | BRACKET, mounting, exhaust pipe extension..... | 1 | ea |
| 04-1 | H1 | 050-3112 | H101-0503112 | | 503112 | NUT, PLAIN, hex, lt, thk, s-fin, S, seize-proof-ctd-thd $\frac{5}{16}$ -24NF-2 | 2 | ea |
| | H1 | | H001-5419781 | | 123473 | SCREW, cap, hex-hd, S, cd- or zn-pltd, $\frac{5}{16}$ -24NF-3 x $\frac{5}{8}$. | 1 | ea |
| 04-1 | H1 | 012-1661 | H001-5419861 | | 121661 | SCREW, cap, hex-hd, S, cd- or zn-pltd, $\frac{5}{16}$ -24NF-3 x 1 | 1 | ea |
| | H1 | 012-0393 | H001-7043711 | | 120393 | WASHER, FLAT, S, cd- or zn-pltd, $1\frac{1}{32}$ ID, $1\frac{1}{16}$ OD, 0.065 thk | 1 | ea |
| 04-1 | | 2990-737-5075 | G740-7375075 | WO-800799 | 7375075 | BRACKET, muffler support clamp..... | 1 | ea |
| 04-1 | H1 | 050-3112 | H101-0503112 | | 503112 | NUT, PLAIN, hex, lt, s-fin, S, seize-proof-ctd-thd, $\frac{5}{16}$ -24NF-2 (M38A1) | 1 | ea |
| | H1 | 050-3348 | H001-0725260 | | 503348 | NUT, SELF-LOCKING, HEXAGON, br, $\frac{5}{16}$ -24NF-3 (Huglock) (M170) | 1 | ea |
| | H1 | 012-3774 | H001-5419901 | | 123774 | SCREW, cap, hex-hd, S, cd- or zn-pltd, $\frac{5}{16}$ -24NF-3 x $1\frac{1}{4}$ (M38A1) | 1 | ea |
| | H1 | 012-1661 | H001-5419861 | | 121661 | SCREW, cap, hex-hd, S, cd- or zn-pltd, $\frac{5}{16}$ -24NF-3 x 1 (M170) | 1 | ea |
| | | | | WO-808980 | | EXTENSION, exhaust pipe (M170)..... | 1 | ea |
| 04-1 | | | G758-8329739 | WO-805779 | 8329739 | EXTENSION, exhaust pipe, w/BRACKET, assy (M38A1) | 1 | ea |
| 04-1 | H1 | 050-3112 | H101-0503112 | | 503112 | NUT, PLAIN, hex, lt, thk, s-fin, S, seize-proof-ctd-thd, $\frac{5}{16}$ -24NF-2 | 6 | ea |
| 04-1 | H1 | 012-1661 | H001-5419861 | | 121661 | SCREW, cap, hex-hd, S, cd- or zn-pltd, $\frac{5}{16}$ -24NF-3 x 1 | 6 | ea |
| 04-2 | | | G758-8333278 | WO-808981 | 8333278 | EXTENSION, exhaust pipe, w BRACKET, assy (M170) | 1 | ea |
| 04-2 | | | G758-8333279 | WO-811293 | 8333279 | EXTENSION, tail pipe, assy (M170)..... | 1 | ea |
| | H1 | 050-3112 | H101-0503112 | | 503112 | NUT, PLAIN, hex, lt, thk, s-fin, S, seize-proof-ctd-thd, $\frac{5}{16}$ -24NF-2 | 3 | ea |
| | H1 | 012-1661 | H001-5419861 | | 121661 | SCREW, cap, hex-hd, S, cd- or zn-pltd, $\frac{5}{16}$ -24NF-3 x 1 (tail pipe extension to muffler flange) | 3 | ea |
| 04-1 | | 2990-360-7970 | G503-7371390 | WO-634814 | 7371390 | GASKET, exhaust pipe flange (manifold end)..... | 1 | ea |
| 04-1 | | 2990-492-5480 | G740-7048736 | WO-A7967 | 7048736 | GASKET (exhaust pipe to extension (1), extension to muffler flange (1)) | 2 | ea |
| 04-1 | | 2990-737-5076 | G740-7375076 | MAR-2539 WO-649865 | 7375076 | MUFFLER, exhaust (includes CLAMP and FLANGES) | 1 | ea |
| 04-1 | | 2990-737-5077 | G740-7375077 | WO-649869 | 7375077 | PIPE, exhaust (includes FLANGES)..... | 1 | ea |
| 04-1 | H1 | 012-0677 | H001-5421341 | | 120677 | BOLT, cap, hex-hd, S, cd- or zn-pltd, $\frac{3}{8}$ -24NF-3 x $1\frac{1}{2}$ | 1 | ea |
| 04-1 | H1 | 050-3354 | H001-0725270 | | 503354 | NUT, SELF-LOCKING HEXAGON, safety, br, $\frac{3}{8}$ - 24NF-3 (critical installation) | 2 | ea |

102

| | | | | | | | |
|--|--|--|-----------|--|---|---|----|
| | | | WO-811540 | | PIPE, tail, w/FLANGE, assy (M170) | 1 | ea |
| | | | WO-811292 | | STUD, exhaust pipe mounting (listed in subgroup 0108) | | |
| | | | | | SUPPORT, angle clamp (M170) | 1 | ea |

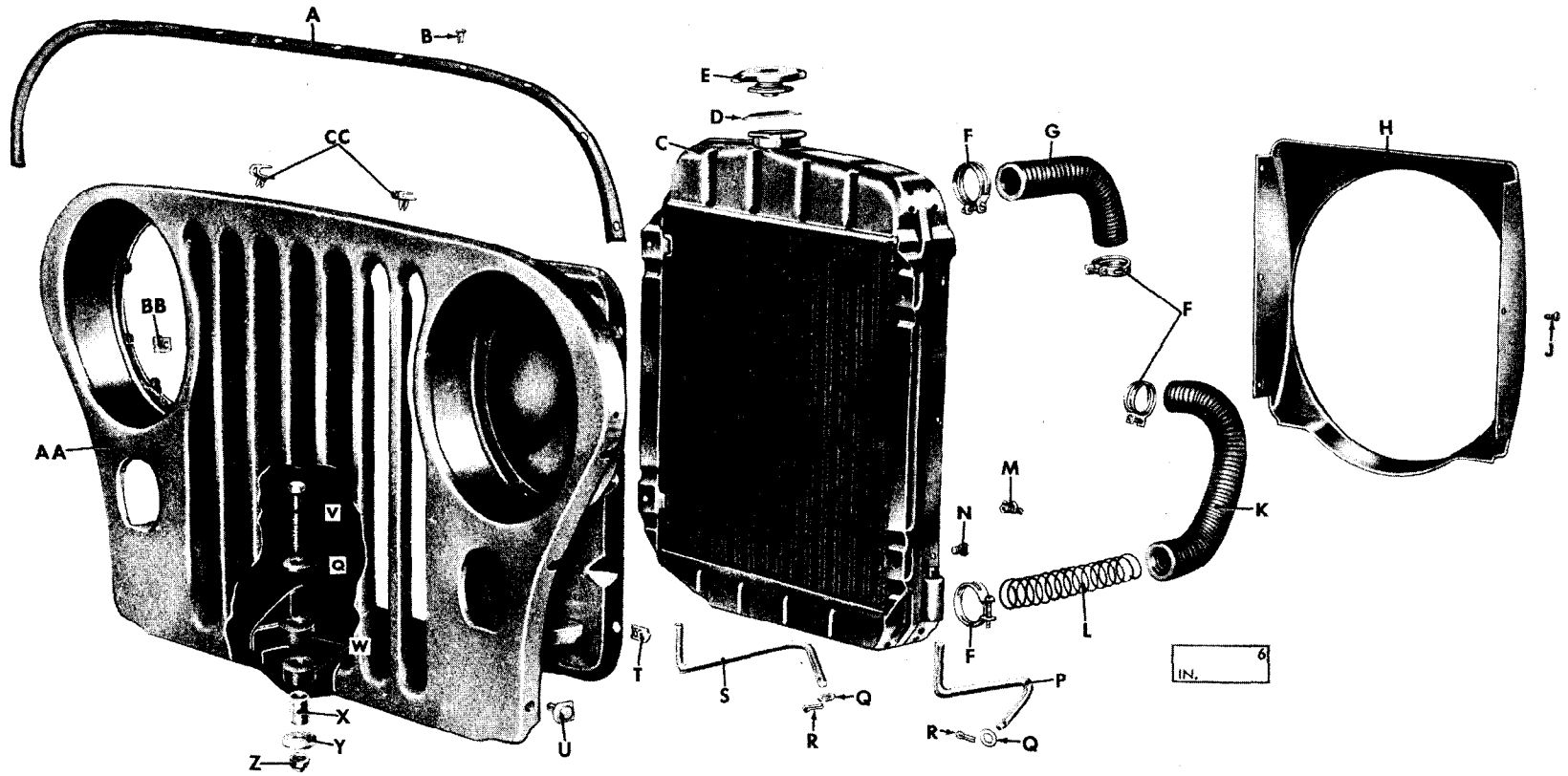

Figure 05-1. Radiator and guard—exploded view

| <i>Key</i> | <i>Item</i> | <i>Part No.</i> | <i>Group</i> |
|------------|------------------------------|-----------------|----------------|
| A | —LINER..... | WO-680420 | 2101 |
| B | —RIVET..... | 113454 | 2101 |
| C | —RADIATOR, ASSY..... | 8328490 | 0501 |
| D | —GASKET..... | WO-810058 | 0501 |
| E | —CAP..... | 7375030 | 0501 |
| F | —CLAMP..... | 502917 | 0503 |
| G | —HOSE..... | 8328457 | 0503 |
| H | —SHROUD..... | 8332473 | 0502 |
| J | —SCREW..... | 161857 | 0502 |
| K | —HOSE..... | 8677625 | 0503 |
| L | —REINFORCEMENT..... | 8673965 | 0503 |
| M | —COCK..... | 103647 | 0501 |
| N | —BOLT..... | 7369880 | 0501 |
| P | —ROD..... | WO-809120 | 0501 |
| Q | —WASHER..... | 120395 | { 0501 2101 |
| R | —PIN..... | 121222 | 0501 |
| S | —ROD..... | WO-809119 | 0501 |
| T | —CLIP..... | 8328493 | 0501 |
| U | —SCREW w/LOCK WASHER..... | 7372886 | 2101 |
| V | —SCREW..... | 124139 | 2101 |
| W | —WASHER..... | WO-683576 | 2101 |
| X | —SPACER..... | WO-683574 | 2101 |
| Y | —WASHER..... | WO-683575 | 2101 |
| Z | —NUT..... | 442830 | 2101 |
| AA | —GUARD, ASSY..... | WO-684570 | 2101 |
| BB | —CLIP..... | 7343086 | 0613.1 |
| CC | —FASTENER..... | 145411 | 0609.1 |

Figure 05-1. Radiator and guard—exploded view—legend

| KEY | ITEM | PART NO. | GROUP |
|-----|------------------|----------|-----------|
| A | PULLEY | 7372816 | 0505 |
| B | BEARING, W/SHAFT | 7372814 | 0504 |
| C | SPRING | 7371385 | 0504 |
| D | BODY | 7372807 | 0504 |
| E | PLUG | 143935 | 0504 |
| F | NIPPLE | 7372808 | 0503 |
| G | WASHER | 7362105 | 0504 |
| H | SEAL, ASSY | 7372809 | 0504 |
| J | IMPELLER | 7371383 | 0504 </td |
| K | GASKET | 7411250 | 0504 |

NOTE: ITEM "K" IS NOT PART OF ASSY 7372806

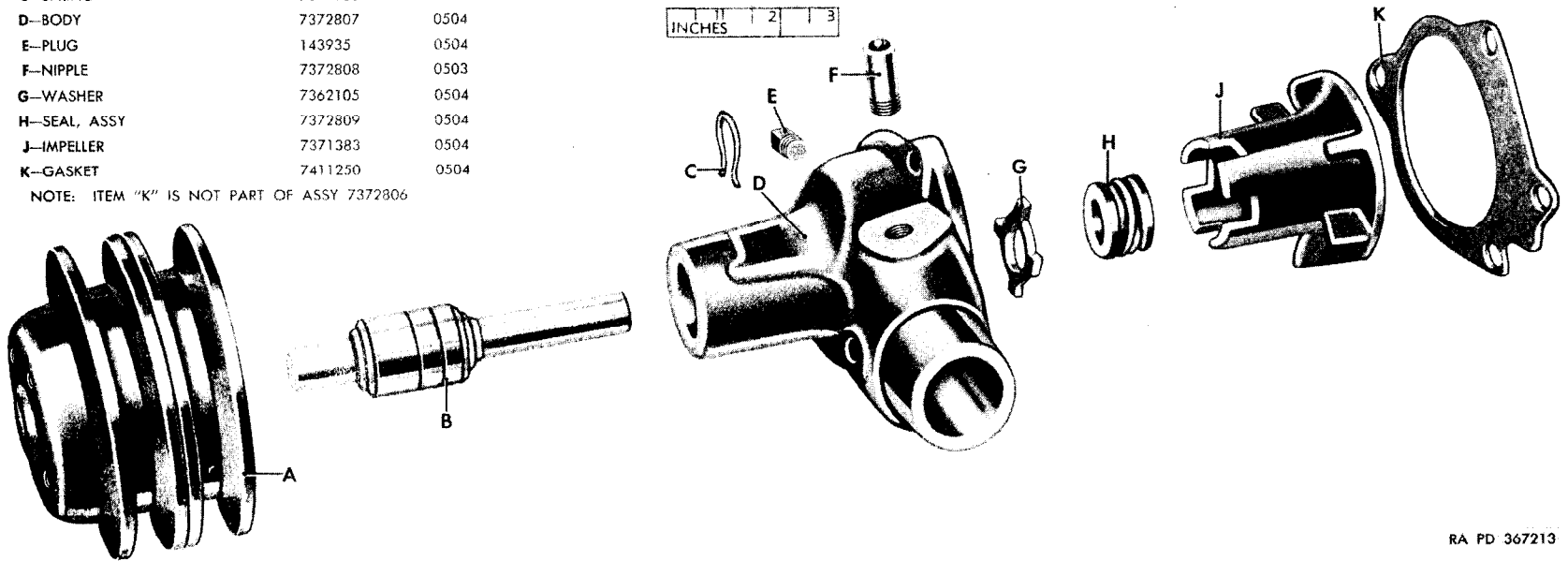

Figure 05-2. Water pump, assy (7372806)—exploded view

| (1) | (2) | (3) | (4) | (5) | (6) | (7) | (8) | (9) |
|--|-------------------|--------------------------|--------------------|-------------------------|-------------------|---|-------------------------------|---------------|
| ILLUSTRATION NO. | REFERENCE SYMBOLS | FEDERAL STOCK NO. | ORDNANCE STOCK NO. | MFR'S PART NO. | ORDNANCE PART NO. | DESCRIPTION | QUANTITY INCORPORATED IN UNIT | UNIT OF ISSUE |
| GROUP 05—COOLING SYSTEM | | | | | | | | |
| 0501—RADIATOR | | | | | | | | |
| 05-1 | | 2930-737-5030 | G740-7375030 | EAT-IE2249 WO-801728 | 7375030 | CAP, filler neck (pressure type)..... | 1 | ea |
| 05-1 | H2 | | H002-8328493 | | 8328493 | CLIP, spring, "J" type, thk (for $\frac{5}{16}$ -10 x $\frac{5}{8}$ acme bolt) (radiator to guard) | 4 | ea |
| 05-1 | H6 | | H106-0103647 | | 103647 | COCK, drain, tee-hdle, br, $\frac{1}{4}$ male pipe end (type C)..... | 1 | ea |
| | | 5330-358-6019 | G501-5262210 | DGM-DG48 WO-A1216 | 5262210 | GASKET, fbr, 1.687 ID, 2.126 OD, 0.062 thk (filler neck cap) (superseded by GASKET WO-810058) | 1 | ea |
| 05-1 | | | | WO-810058 | | GASKET, ru, 1.687 ID, 2.126 OD, 0.066 thk (filler neck cap) (supersedes GASKET 5262210) | 1 | ea |
| 05-1 | | 2930-371-3102 | G758-8328490 | WO-805825 | 8328490 | RADIATOR, assy (includes NECK)..... | 1 | ea |
| 05-1 | | 5305-275-1660 | G740-7369880 | WO-648438 | 7369880 | BOLT, ASSEMBLED WASHER, hex-hd, $\frac{5}{16}$ -10 x $\frac{5}{8}$ (Acme bolt) (radiator to guard) | 4 | ea |
| | | | G758-8328492 | WO-805823 | 8328492 | ROD, support, left (to engine) (superseded by ROD WO-809119) | 1 | ea |
| 05-1 | | | | WO-809119 | | ROD, support, left (to engine) (supersedes ROD 8328492) | 1 | ea |
| | | | G758-8328491 | WO-805824 | 8328491 | ROD, support, right (to engine) (superseded by ROD WO-809120) | 1 | ea |
| 05-1 | | | | WO-809120 | | ROD, support, right (to engine) (supersedes ROD 8328491) | 1 | ea |
| 05-1 | H1 | 012-1222 | H101-0121222 | | 121222 | PIN, cotter, split, S, cd- or zn-pltd, $\frac{3}{32}$ x $\frac{3}{4}$ | 2 | ea |
| 05-1 | H1 | 5310-012-0395 | H001-7043771 | | 120395 | WASHER, FLAT, S, cd- or zn-pltd, $\frac{15}{32}$ ID, $\frac{59}{64}$ OD, 0.065 thk | 2 | ea |
| | | | | WO-684915 | | ROD, tie, left (dash to air deflector) (used on vehicles after serial No. 60406) | 1 | ea |
| | | | | WO-684577 | | ROD, tie, right (dash to air deflector) (used on vehicles after serial No. 60406) | 1 | ea |
| | H1 | | H101-0271193 | | 271193 | NUT, assembled washer, hex, ext-teeth lock washer, S, cd- or zn-pltd, $\frac{3}{8}$ -24NF (tie rods to deflector) | 4 | ea |
| | H1 | 012-0368 | H001-4167561 | | 120368 | NUT, PLAIN, hex, lt, s-fin, S, cd- or zn-pltd, $\frac{5}{16}$ -24NF-2 (tie rods to dash) | 2 | ea |
| | | | | WO-808319 | | SCREW, lock washer, hex-hd, S, cd- or zn-pltd, $\frac{5}{16}$ -24NF x $\frac{1}{8}$ (radiator tie rods to dash) | 2 | ea |
| | H1 | 5310-012-0394 | H001-7043741 | | 120394 | WASHER, flat, S, cd- or zn-pltd, $\frac{13}{32}$ ID, $\frac{13}{16}$ OD, 0.065 thk (tie rods to deflector) | 4 | ea |
| 0502—RADIATOR AIR DEFLECTORS AND SHROUD | | | | | | | | |
| | | | | WO-683310 | | BRACKET, tie rod, air deflector and radiator guard (used on vehicles after serial No. 60406) | 1 | ea |

| (1) ILLUSTRATION NO. | (2) REFERENCE SYMBOLS | (3) FEDERAL STOCK NO. | (4) ORDNANCE STOCK NO. | (5) MFR'S PART NO. | (6) ORDNANCE PART NO. | (7) DESCRIPTION | (8) QUANTITY INCORPORATED IN UNIT | (9) UNIT OF ISSUE |
|--|--------------------------|--------------------------|------------------------------|------------------------|--------------------------|---|--------------------------------------|----------------------|
| GROUP 05—COOLING SYSTEM—Continued | | | | | | | | |
| 0502—RADIATOR AIR DEFLECTORS AND SHROUD—Continued | | | | | | | | |
| | | | | WO-680253 | 8677605 | DEFLECTOR, air, radiator (welded) (used on vehicles through serial No. 60406) | 1 | ea |
| | | | | WO-685403 | | DEFLECTOR, air, radiator, upper (welded) (used on vehicles after serial No. 60406) | 1 | ea |
| | | | | WO-685404 | | DEFLECTOR, air, radiator, lower (welded) (used on vehicles after serial No. 60406) | 1 | ea |
| | | | | WO-685405 | | DEFLECTOR, side, air, radiator, left (welded) (used on vehicles after serial No. 60406) | 1 | ea |
| | | | | WO-685406 | | DEFLECTOR, side, air, radiator, right (welded) (used on vehicles after serial No. 60406) | 1 | ea |
| | | | | WO-684538 | | PLATE, support and reinforcing, air deflector (used on vehicles after serial No. 60406) | 1 | ea |
| 05-1 | | | G758-8332473 | WO-806322 | 8332473 | SHROUD, radiator | 1 | ea |
| 05-1 | H1 | 5305-016-1857 | H101-0161857 | | 161857 | SCREW, tapping, thread forming, cross-recess-pan-hd, gimlet-pt, sh-met-thd, S, cd- or zn-pltd, No. 8 (0.165) x $\frac{3}{8}$ | 6 | ea |
| 0503—WATER HOSES AND THERMOSTAT | | | | | | | | |
| | | | G758-8328455 | WO-807710 | 8328455 | CLAMP, hose, S, cd- or zn-pltd, 1.906 in (radiator) (superseded by CLAMP 502917) | 4 | ea |
| 05-1 | H6 | | H006-0502917 | | 502917 | CLAMP, hose, S, cd- or zn-pltd, 1½ in. (supersedes CLAMP 8328455) | 4 | ea |
| | H6 | | H006-0211120 | | 500653 | CLAMP, hose, S, rustproof, $\frac{15}{16}$ in. (water by-pass, pump cylinder head hose) (used on engines through serial No. 11889) | 2 | ea |
| | H6 | | H006-0211612 | | 500658 | CLAMP, hose, S, zn-pltd, $\frac{15}{16}$ in. (water by-pass pump to cylinder head hose) (used on engines after serial No. 11889 and through serial No. 95344) | 2 | ea |
| | H6 | | H006-8330945 | | 8330945 | CLAMP, hose, $\frac{13}{16}$ in. (used on engines after serial No. 95344) | 2 | ea |
| 01-1 | | 4720-769-7588 | G758-8328456 G740-7697588 | WO-648852 WO-801047 | 8328456 7697588 | GASKET, thermostat housing HOSE, ru, $\frac{17}{32}$ ID, 4¼ in. (water by-pass, pump to cylinder head) | 1 1 | ea ea |
| | | | G758-8328458 | WO-805822 | 8328458 | HOSE, w/REINFORCEMENT, assy (radiator water outlet to water pump) (lower) | 1 | ea |
| 05-1 | | | G758-8328457 | WO-805820 | 8328457 | HOSE, water (upper) | 1 | ea |

| | | | | | | | |
|------------|-----|---------------|------------------------------|---------------------------------|---|---|----|
| 05-1 | | | WO-805821 | 8677625 | HOSE, ru, 1½ ID x 13¾ dev-lg (water outlet, lower) (moulded) | 1 | ea |
| | H1 | | G758-8332060 H101-9409098 | WO-800293 8332060 9409098 | HOUSING, thermostat | 1 | ea |
| 01-5; 05-2 | | 4730-737-2808 | G740-7372808 | WO-649720 | BOLT, MACHINE, assembled washer, hex-hd, split lock washer, header-pt, S, cd- or zn-pltd, 5/16-18UNC-2A x 7/8 | 3 | ea |
| 05-1 | | | G716-8329966 | WO-645905 WO-646232 | NIPPLE, hose, ¼-18NF pipe thd x 1¼ (cylinder head (1); water pump (1)) | 2 | ea |
| | | 2930-734-8571 | G740-7348571 | SDH-SA752-8 WO-646812 | REINFORCEMENT, hose (spring type) | 1 | ea |
| 01-3 | | | | WO-812050 | THERMOSTAT, water temperature (optional w/THERMOSTAT 7348571) (superseded by THERMOSTAT WO-812050) | 1 | ea |
| | | | | | THERMOSTAT, water temperature (optional w/THERMOSTAT 8329966) (superseded by THERMOSTAT WO-812050) | 1 | ea |
| | | | | | THERMOSTAT, water temperature (supersedes THERMOSTAT 7348571 and 8329966) | 1 | ea |
| | | | | | 0504 - WATER PUMP | | |
| 05-2 | H12 | | H012-7372814 | 7372814 | BEARING, w/SHAFT, assy | 1 | ea |
| 05-2 | | 2930-737-2807 | G740-7372807 | WO-800885 | BODY | 1 | ea |
| 05-2 | | 2930-354-3772 | G716-7411250 | WO-637053 | GASKET, pump to cylinder block | 1 | ea |
| 05-2 | | 2930-737-1383 | G503-7371383 | WO-639993 | IMPELLER | 1 | ea |
| 05-2 | H6 | 014-3935 | H006-0283570 | 143935 | PLUG, PIPE, sq-hd, CI, cd- or zn-pltd, ½ in. (optional w/PLUG 143981) | 1 | ea |
| | H6 | 014-3981 | H106-0143981 | 143981 | PLUG, PIPE, sq-hd, S, cd- or zn-pltd, ½ in. (optional w/PLUG 143935) | 1 | ea |
| 01-3 | | 2930-737-2806 | G740-7372806 | WO-800002 | PUMP, water, assy | 1 | ea |
| | H1 | | H101-9409098 | 9409098 | BOLT, MACHINE, assembled washer, hex-hd, split lock washer, header-pt, S, cd- or zn-pltd, 5/16-18UNC-2A x 7/8 | 3 | ea |
| | H1 | | H101-0455145 | 455145 | SCREW, mach, lock washer, hex-hd, S, cd- or zn-pltd, 5/16-18NC-2 x 2½ | 1 | ea |
| 05-2 | | 2930-737-2809 | G740-7372809 | WO-801048 | SEAL, w/SPRING, assy (optional w/SEAL 7372810) | 1 | ea |
| | | 2930-737-2810 | G740-7372810 | WO-801049 | SEAL, w/SPRING, assy (optional w/SEAL 7372809) | 1 | ea |
| 05-2 | | 5330-360-8066 | G503-7371385 | WO-636298 | SPRING, retaining, bearing | 1 | ea |
| 05-2 | | 2930-360-8060 | G503-7362105 | CPH-BW5-625 WO-640034 | WASHER, special, 4-ext-teeth, S, 1¼ ID, 1 5/8 OD, 1/8 in. thk (seal) | 1 | ea |
| | | | | | 0505 - FAN BELTS AND PULLEY | | |
| 01-1 | | | G740-7697614 | DAY-S5203 WO-801699 | BELT, drive, fan and generator (optional w/BELT FDP-NDD153) | 2 | ea |
| | | | | FDP-NDD153 WO-806764 | BELT, drive, fan and generator (optional w/BELT 7697614) | 2 | ea |
| 01-1, 3 | | | G740-7375021 | SZ-123770 WO-802187 | BLADE, fan engine, assy | 1 | ea |
| | H1 | | H101-9409107 | 9409107 | BOLT, MACHINE, assembled washer, hex-hd, split lock washer, S, cd- or zn-pltd, ¼-20UNC-2A x 5/8 | 4 | ea |
| 05-2 | | 3020-737-2816 | G740-7372816 | WO-649721 | PULLEY, driven, fan and water pump (twin groove) | 1 | ea |

| KEY ITEM | PART NO. | KEY ITEM | PART NO. | KEY ITEM | PART NO. |
|------------|----------|-------------------|----------|----------------|----------|
| A—PIN | 121224 | Q—WASHER | 7374859 | EE—END BRACKET | 7374749 |
| B—NUT | 125043 | R—RETAINER | 7374860 | FF—BOLT | 132119 |
| C—WASHER | 120384 | S—PLUG | 500718 | GG—SCREW | 132138 |
| D—KEY | 124545 | T—END BRACKET | 7374748 | HH—SCREW | 132110 |
| E—PULLEY | 7375071 | U—PACKING | 7412437 | JJ—END BRACKET | 7374886 |
| F—RETAINER | 7374855 | V—FRAME, ASSY | 7374851 | KK—BEARING | 712128 |
| G—PACKING | 7375328 | W—GASKET | 7716562 | LL—SCREW | 132128 |
| H—PACKING | 501234 | X—SCREW | 131966 | MM—SLINGER | 7374746 |
| J—SPACER | 7374856 | Y—ELBOW | 7716690 | NN—PIN | 7374861 |
| K—SEAL | 7374863 | Z—RECEPTACLE | 7388319 | PP—PACKING | 7375329 |
| L—GEAR | 7412438 | AA—SCREW | 131970 | QQ—PLUG | 7374854 |
| M—WASHER | 7374857 | BB—ARMATURE, ASSY | 7374853 | RR—SCREW | 131958 |
| N—BEARING | 712125 | CC—BRUSH SET | 7374852 | | |
| P—RETAINER | 7374858 | DD—SCREW | 8332226 | | |

NOTE: ALL THE ABOVE PARTS ARE IN GROUP 0601.1

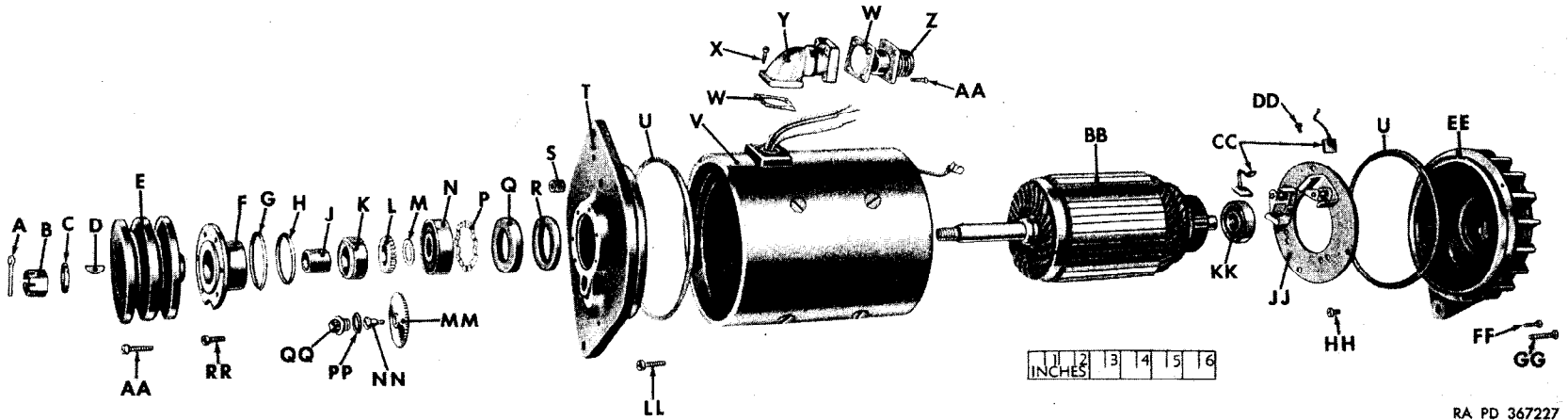

RA PD 367227

Figure 06-1. Generator, assy (8673350) Auto-Lite, 24-volt—exploded view

| KEY ITEM | PART NO. |
|---------------------|----------|
| A—NUT | 453327 |
| B—WASHER | 120396 |
| C—PULLEY | 7375071 |
| D—SCREW | 453281 |
| E—WASHER | 453473 |
| F—BOLT W/LOCKWASHER | 423571 |
| G—WASHER | 120394 |
| H—BRACE | 7375388 |
| J—BOLT | 7371188 |
| K—WASHER | 120382 |
| L—NUT | 120369 |
| M—HEAD | 7538756 |
| N—PACKING | 546886 |
| P—BEARING | 7413226 |
| Q—PLATE | 7538760 |
| R—BRUSH, ASSY | 7538784 |

| KEY ITEM | PART NO. |
|--------------------|------------|
| S—ARMATURE | 7413317 |
| T—SHOE | DR-1921755 |
| U—SCREW | 453847 |
| V—WASHER | 453299 |
| W—RECEPTACLE, ASSY | 7388319 |
| X—GASKET | 7716562 |
| Y—ELBOW | 7716690 |
| Z—BOLT | 131987 |
| AA—CAPACITOR | 7538751 |
| BB—SCREW | 453308 |
| CC—PLUG | 7391017 |
| DD—GASKET | 7391018 |
| EE—PLATE, ASSY | 7413318 |
| 1—SPRING | 7413315 |
| 2—HOLDER | 7373350 |
| 3—WASHER | 7538767 |
| 4—PLATE | DR-1921761 |

NOTE: ALL PARTS LISTED ARE IN GROUP 0601.3
ITEMS A, B, C, F, G, H, J, K AND L ARE NOT
PART OF ASSEMBLY 7355736

1 2 3 4 5 6
INCHES

111

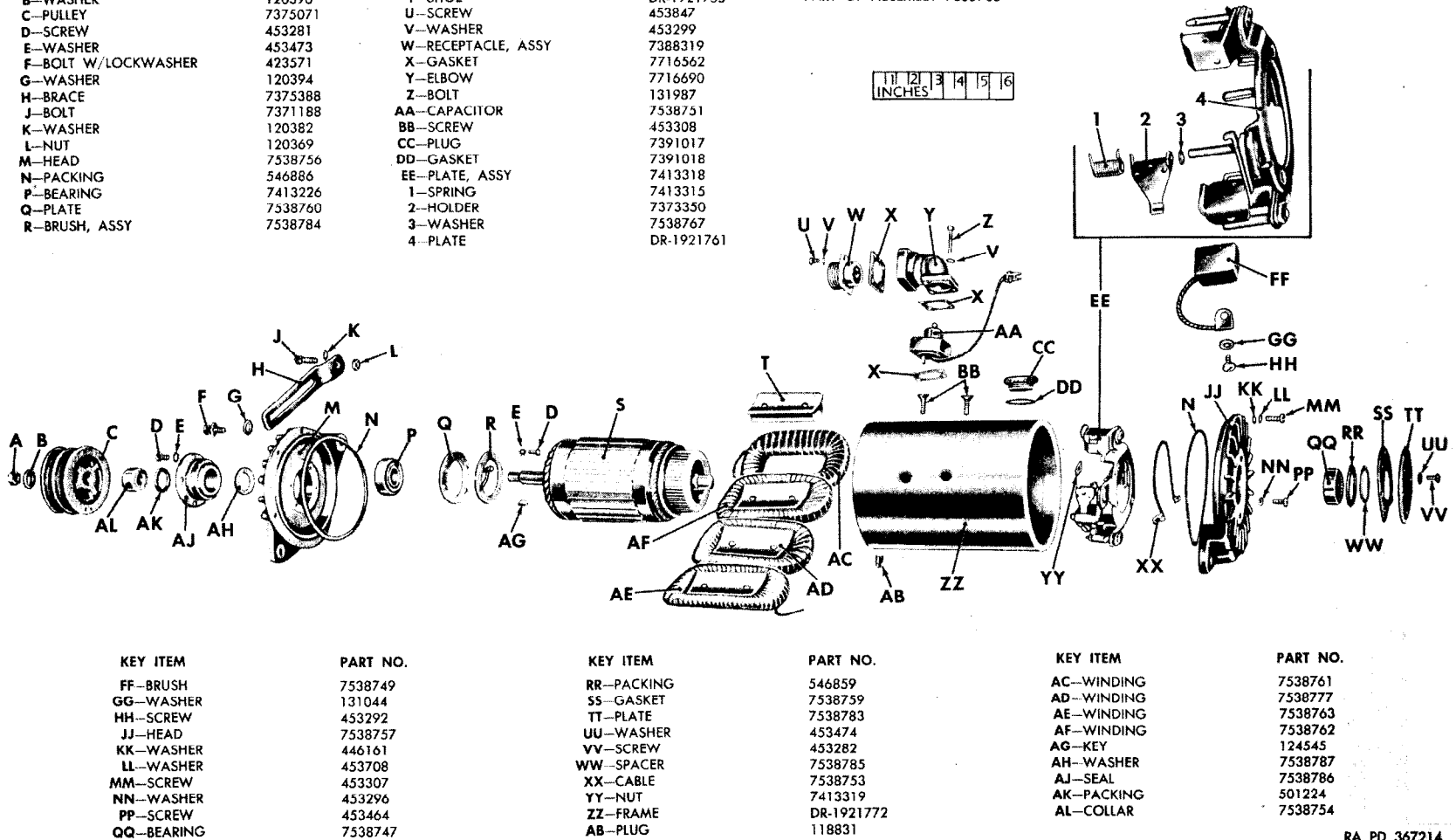

| KEY ITEM | PART NO. |
|------------|----------|
| FF—BRUSH | 7538749 |
| GG—WASHER | 131044 |
| HH—SCREW | 453292 |
| JJ—HEAD | 7538757 |
| KK—WASHER | 446161 |
| LL—WASHER | 453708 |
| MM—SCREW | 453307 |
| NN—WASHER | 453296 |
| PP—SCREW | 453464 |
| QQ—BEARING | 7538747 |

| KEY ITEM | PART NO. |
|------------|------------|
| RR—PACKING | 546859 |
| SS—GASKET | 7538759 |
| TT—PLATE | 7538783 |
| UU—WASHER | 453474 |
| VV—SCREW | 453282 |
| WW—SPACER | 7538785 |
| XX—CABLE | 7538753 |
| YY—NUT | 7413319 |
| ZZ—FRAME | DR-1921772 |
| AB—PLUG | 118831 |

| KEY ITEM | PART NO. |
|------------|----------|
| AC—WINDING | 7538761 |
| AD—WINDING | 7538777 |
| AE—WINDING | 7538763 |
| AF—WINDING | 7538762 |
| AG—KEY | 124545 |
| AH—WASHER | 7538787 |
| AJ—SEAL | 7538786 |
| AK—PACKING | 501224 |
| AL—COLLAR | 7538754 |

RA PD 367214

Figure 06-2. Generator, assy (7355736) Delco-Remy, 24-volt—exploded view

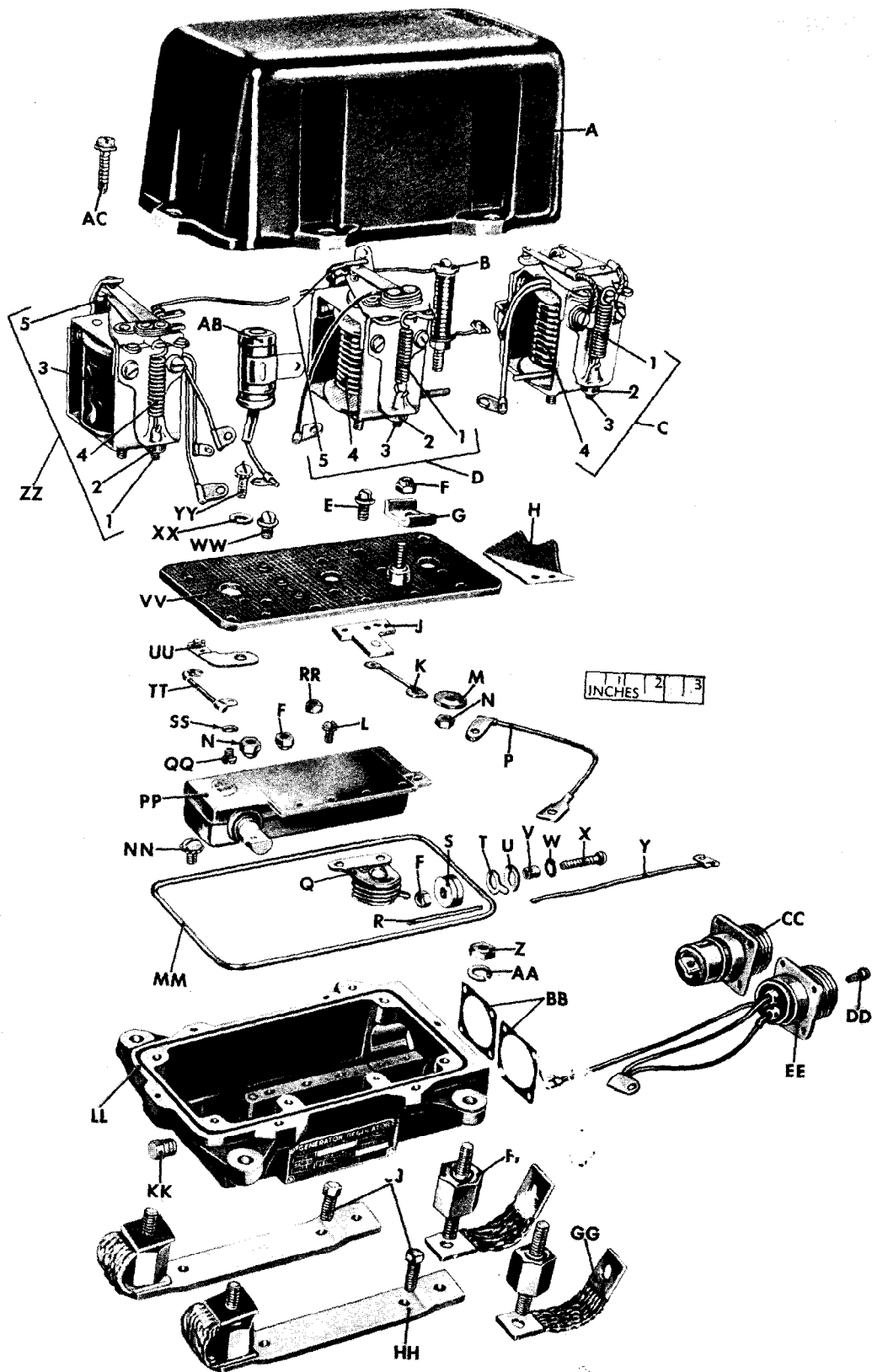

Figure 06-3. Generator, regulator (7524309) Auto-Lite, 24-volt—exploded view

| <i>Key</i> | <i>Item</i> | <i>Part No.</i> | <i>Key</i> | <i>Item</i> | <i>Part No.</i> |
|------------|-----------------------|-----------------|------------|------------------------|-----------------|
| A | -COVER..... | 7374825 | Z | -NUT..... | 426894 |
| B | -CHOKE..... | 7374920 | AA | -WASHER..... | 221177 |
| C | -BREAKER, ASSY..... | 7374945 | BB | -GASKET..... | AL-XA767A |
| | 1-SPRING..... | 7702646 | CC | -RECEPTACLE, ASSY..... | 7374924 |
| | 2-NUT..... | 7702608 | DD | -SCREW..... | AL-X3051 |
| | 3-SCREW..... | 7702665 | EE | -RECEPTACLE, ASSY..... | 7374925 |
| | 4-ARMATURE..... | AL-VBC1029 | FF | -CUSHION, ASSY..... | 7374922 |
| D | -REGULATOR, ASSY..... | 7374943 | GG | -STRAP..... | 7374965 |
| | 1-SPRING..... | 7702646 | HH | -BRACKET..... | 7374823 |
| | 2-NUT..... | 7702608 | JJ | -BOLT..... | 187979 |
| | 3-SCREW..... | 7702665 | KK | -PLUG..... | 444614 |
| | 4-ARMATURE..... | AL-VBC1061 | LL | -CASE..... | 8673471 |
| | 5-BRACKET..... | AL-VRA1060A | MM | -PACKING..... | 546896 |
| E | -SCREW..... | 7375371 | NN | -BOLT..... | 424632 |
| F | -NUT..... | AL-XA699A | PP | -FILTER, ASSY..... | 7374923 |
| G | -CONNECTOR..... | 7348949 | QQ | -SCREW..... | 120628 |
| H | -PLATE..... | 8393094 | RR | -NUT..... | 503240 |
| J | -BRACKET..... | 7374822 | SS | -WASHER..... | 131015 |
| K | -RESISTOR..... | 7374961 | TT | -RESISTOR..... | 8332078 |
| L | -BOLT..... | 178469 | UU | -BRACKET..... | 7374921 |
| M | -WASHER..... | 446187 | VV | -BASE..... | 7374917 |
| N | -NUT..... | 503342 | WW | -SCREW..... | AL-X3055 |
| P | -LEAD, ASSY..... | 8393090 | XX | -WASHER..... | 120391 |
| Q | -RECTIFIER..... | 7374960 | YY | -SCREW..... | 132908 |
| R | -LEAD..... | 8393095 | ZZ | -REGULATOR, ASSY..... | 7374944 |
| S | -RESISTOR..... | 8393091 | | 1-SCREW..... | 7702665 |
| T | -TERMINAL..... | 8672286 | | 2-NUT..... | 7702608 |
| U | -WASHER..... | 8672285 | | 3-ARMATURE..... | AL-VBC1080 |
| V | -BUSHING..... | 8393092 | | 4-SPRING..... | 7702645 |
| W | -WASHER..... | 116090 | | 5-BRACKET..... | AL-VRA1060A |
| X | -SCREW..... | 132923 | AB | -CAPACITOR, ASSY..... | 7374919 |
| Y | -LEAD, ASSY..... | 8393093 | AC | -BOLT..... | 127651 |

Note: All parts listed are in group 0602.

Figure 06-3. Generator, regulator (7524309) Auto-Lite, 24-volt—exploded view—legend

| KEY | ITEM | PART NO | KEY | ITEM | PART NO. |
|-----|----------------|-------------|-----|----------|------------|
| A | HEAD, ASSY | 8328135 | V | RING | 7347572 |
| B | BRUSH | AL-MCS1034S | W | WASHER | 7369888 |
| C | PLATE, ASSY | 7374938 | X | HOUSING | 8328136 |
| D | SPRING | 7375301 | Y | RETAINER | 8328071 |
| E | PACKING | 546875 | Z | WASHER | 426678 |
| F | BRUSH | AL-MCS12 | AA | SCREW | AL-19X888 |
| G | FRAME, ASSY | 8328056 | BB | PACKING | 501220 |
| H | NUT | 7347571 | CC | BEARING | 5346762 |
| J | WASHER | 432646 | DD | SHAFT | 8328067 |
| K | CONNECTOR | 8328140 | EE | SCREW | AL-19X3168 |
| L | SWITCH, ASSY | 8328134 | FF | NUT | 124920 |
| M | SCREW | AL-19X709 | GG | LEVER | AL-MCZ1075 |
| N | WASHER | 431680 | HH | PIN | 137185 |
| P | WASHER | 5308275 | JJ | KEY | 124543 |
| Q | WASHER | 8328058 | KK | SCREW | 271122 |
| R | ARMATURE, ASSY | 8328057 | LL | SCREW | 133482 |
| S | CLUTCH, ASSY | 8328139 | MM | WICK | 5308307 |
| T | YOKE, ASSY | 8328069 | NN | SCREW | 131970 |
| U | RETAINER | 7374940 | | | |

NOTE: ALL PARTS ARE IN GROUP 0603

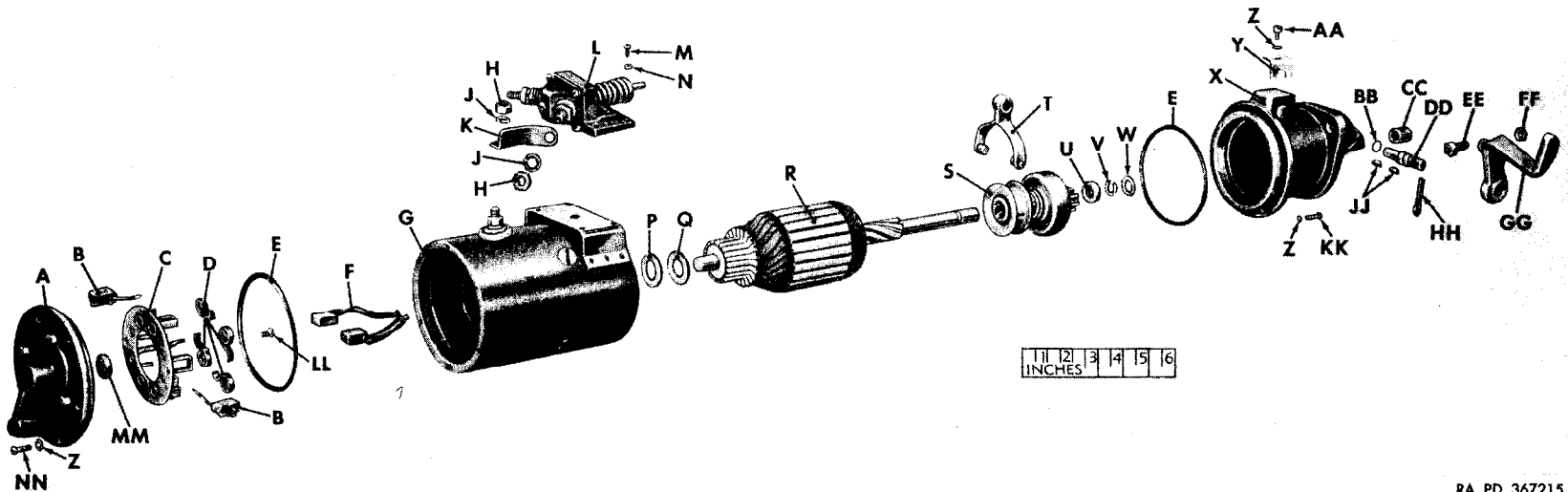

Figure 06-4. Starter, assy (8328132) Auto-Lite, 24-volt—exploded view

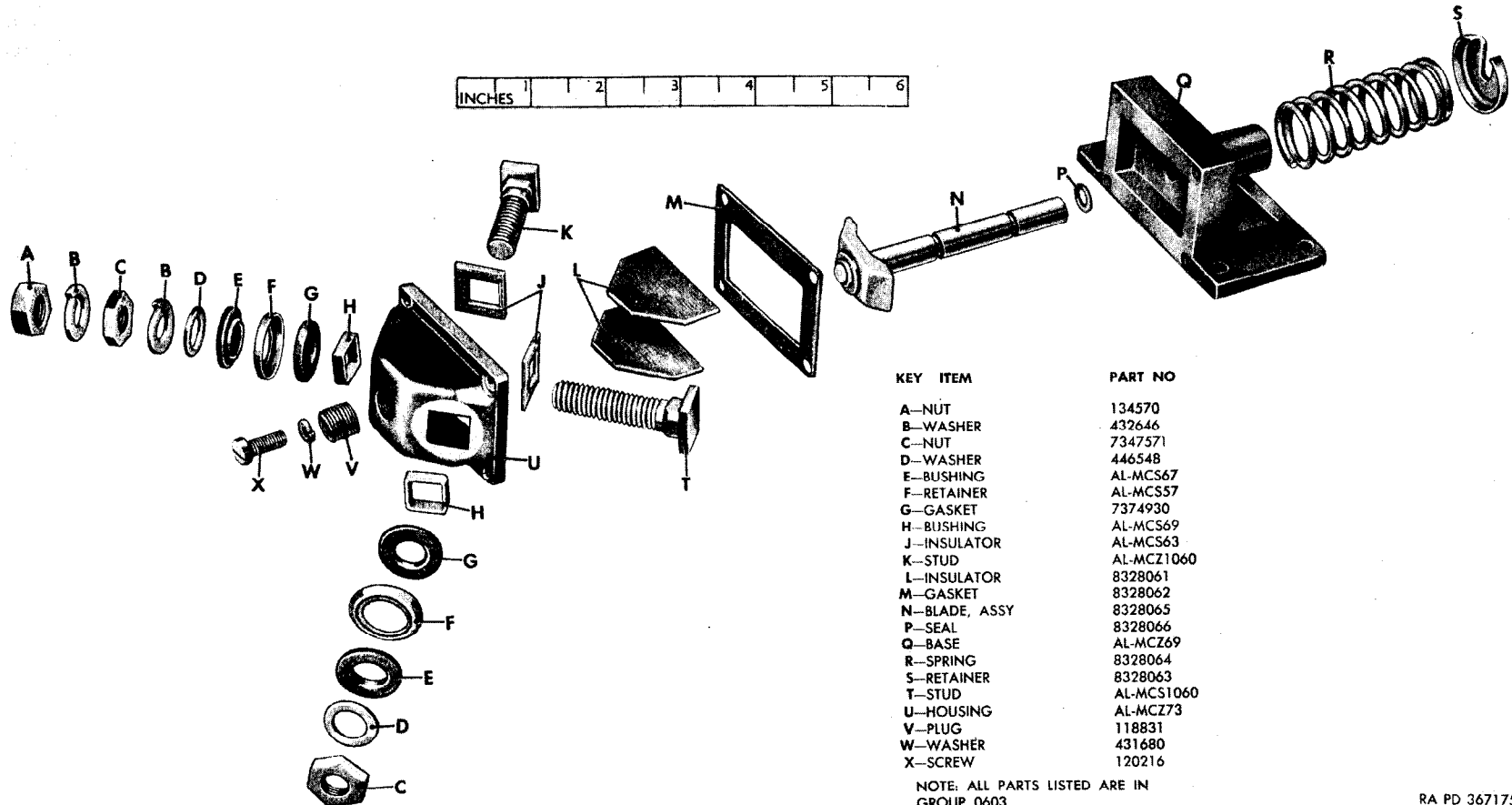
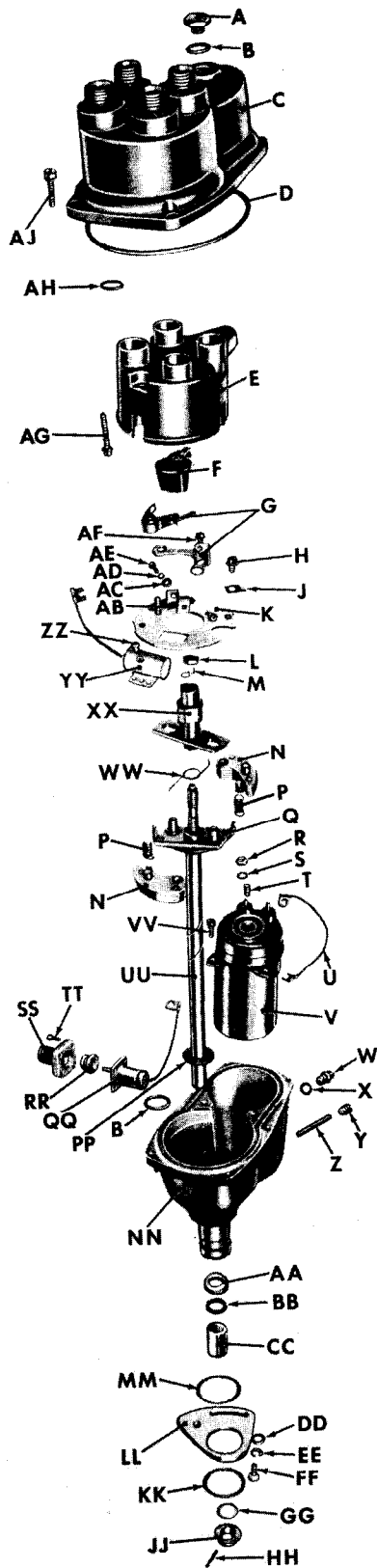

Figure 06-5. Starter switch, assy (8328134)—exploded view



| KEY | ITEM | PART NO | GROUP |
|-----|--------------------|------------|--------|
| A | PLUG | 7374888 | 0604.1 |
| B | PACKING | 501223 | 0604.1 |
| C | COVER, ASSY | 7375373 | 0604.1 |
| D | PACKING | 546880 | 0604.1 |
| E | CAP | 7375377 | 0604.1 |
| F | ROTOR | 7348578 | 0604.1 |
| G | POINT SET | 5346774 | 0604.1 |
| H | SCREW W/LOCKWASHER | 591400 | 0604.1 |
| J | HOLDER | 7374885 | 0604.1 |
| K | PLATE | 7374887 | 0604.1 |
| L | WICK | 5346784 | 0604.1 |
| M | RING | 5346767 | 0604.1 |
| N | WEIGHT | 7706790 | 0604.1 |
| P | SPRING | AL-IGB-284 | 0604.1 |
| Q | SPACER | 5346768 | 0604.1 |
| R | NUT | 120614 | 0604.1 |
| S | WASHER | 431680 | 0604.1 |
| T | SPRING | 7374893 | 0604.1 |
| U | LEAD, ASSY | 7374878 | 0604.1 |
| V | COIL | 7374882 | 0605 |
| W | PLUG | 7347547 | 0604.1 |
| X | WASHER | 7346969 | 0604.1 |
| Y | PLUG | 118831 | 0604.1 |
| Z | WICK | 8329787 | 0604.1 |
| AA | SEAL | 7351671 | 0604.1 |
| BB | WASHER | AL-IAU10 | 0604.1 |
| CC | BUSHING | 542109 | 0604.1 |
| DD | WASHER | 120387 | 0604.1 |
| EE | WASHER | 431543 | 0604.1 |
| FF | BOLT | 214002 | 0604.1 |
| GG | WASHER | 5307283 | 0604.1 |
| HH | PIN | 112011 | 0604.1 |
| JJ | COLLAR | 7351133 | 0604.1 |
| KK | GASKET | 7375110 | 0604.1 |
| LL | ARM | 7375372 | 0604.1 |
| MM | WASHER | 7374895 | 0604.1 |
| NN | BASE, ASSY | 8329785 | 0604.1 |
| PP | WASHER | 7980860 | 0604.1 |
| QQ | CAPACITOR, ASSY | 8329784 | 0604.1 |
| RR | SEAL | 8328076 | 0604.1 |
| SS | RECEPTACLE | 8329786 | 0604.1 |
| TT | SCREW W/LOCKWASHER | 455215 | 0604.1 |
| UU | SHAFT | 7375376 | 0604.1 |
| VV | SCREW W/LOCKWASHER | 455214 | 0605 |
| WW | SPRING | 7412960 | 0604.1 |
| XX | CAM | 7375378 | 0604.1 |
| YY | CAPACITOR, ASSY | 7374881 | 0604.1 |
| ZZ | SCREW W/LOCKWASHER | 455209 | 0604.1 |
| AB | CLIP | 5346775 | 0604.1 |
| AC | WASHER | 131014 | 0604.1 |
| AD | WASHER | 500494 | 0604.1 |
| AE | SCREW | 583842 | 0604.1 |
| AF | SCREW | 455210 | 0604.1 |
| AG | SCREW W/LOCKWASHER | 455219 | 0604.1 |
| AH | WASHER | 7374894 | 0604.1 |
| AJ | SCREW W/LOCKWASHER | 7375371 | 0604.1 |



RA PD 367217

Figure 06-6. Distributor assy (7358569) Auto-Lite, 24-volt—exploded view

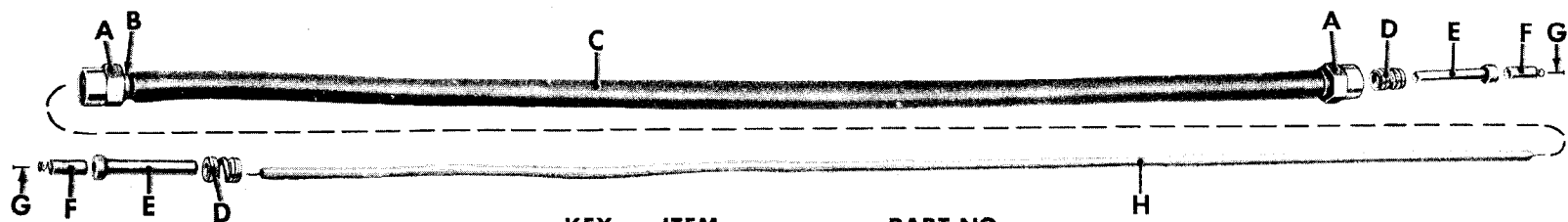

| KEY | ITEM | PART NO |
|-----|--------------|---------|
| A | NUT | 7528187 |
| B | FERRULE | 7528193 |
| C | CONDUIT | 7528197 |
| D | SPRING, ASSY | 7526961 |
| E | INSULATOR | 7526949 |
| F | SLEEVE, ASSY | 7526951 |
| G | PIN | 7526940 |
| H | CABLE | 812337 |

NOTE: ALL PARTS LISTED ABOVE ARE
IN GROUP 0605.

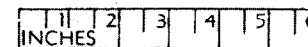

RA PD 181675

Figure 06-7. Spark plug cable, assy (8328449)—exploded view

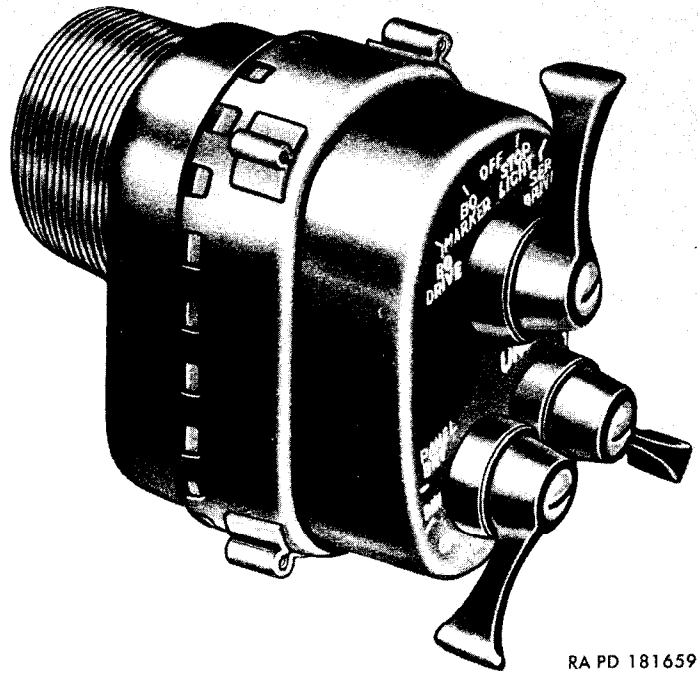
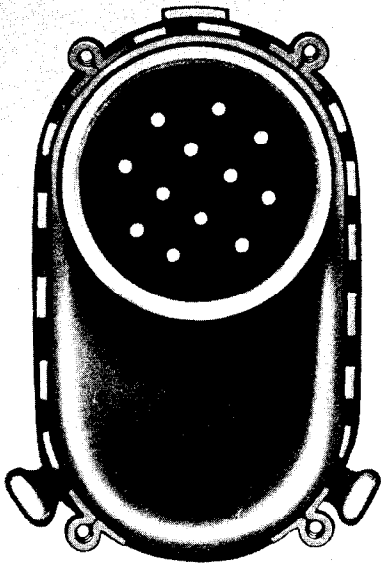

RA PD 181659

Figure 06-8. Light switch (7368702)

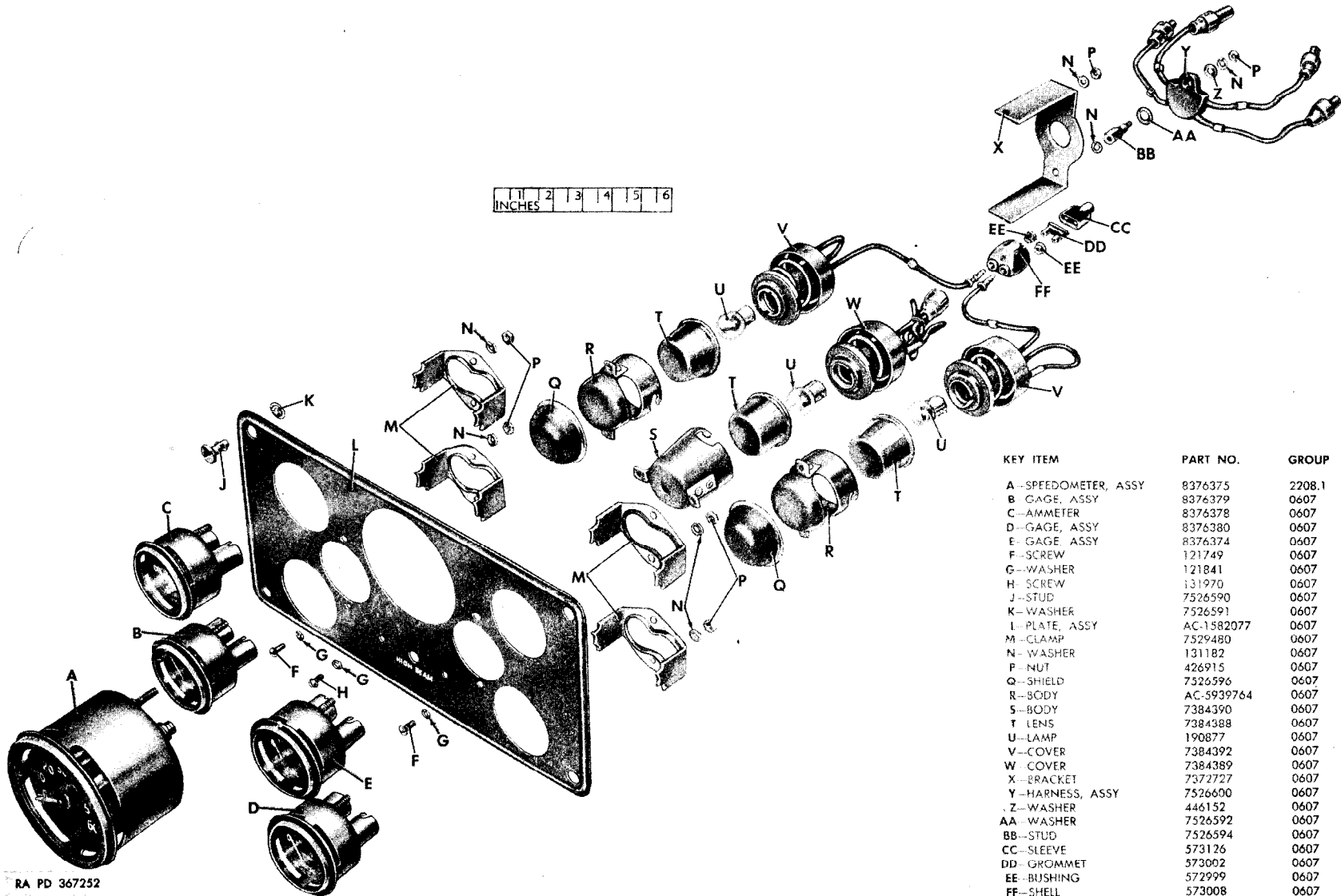

| KEY ITEM | PART NO. | GROUP |
|----------------------|------------|--------|
| A--SPEEDOMETER, ASSY | 8376375 | 2208.1 |
| B--GAGE, ASSY | 8376379 | 0607 |
| C--AMMETER | 8376378 | 0607 |
| D--GAGE, ASSY | 8376380 | 0607 |
| E--GAGE, ASSY | 8376374 | 0607 |
| F--SCREW | 121749 | 0607 |
| G--WASHER | 121841 | 0607 |
| H--SCREW | 131970 | 0607 |
| J--STUD | 7526590 | 0607 |
| K--WASHER | 7526591 | 0607 |
| L--PLATE, ASSY | AC-1582077 | 0607 |
| M--CLAMP | 7529480 | 0607 |
| N--WASHER | 131182 | 0607 |
| P--NUT | 426915 | 0607 |
| Q--SHIELD | 7526596 | 0607 |
| R--BODY | AC-5939764 | 0607 |
| S--BODY | 7384390 | 0607 |
| T--LENS | 7384388 | 0607 |
| U--LAMP | 190877 | 0607 |
| V--COVER | 7384392 | 0607 |
| W--COVER | 7384389 | 0607 |
| X--BRACKET | 7372727 | 0607 |
| Y--HARNES, ASSY | 7526000 | 0607 |
| Z--WASHER | 446152 | 0607 |
| AA--WASHER | 7526592 | 0607 |
| BB--STUD | 7526594 | 0607 |
| CC--SLEEVE | 573126 | 0607 |
| DD--GROMMET | 573002 | 0607 |
| EE--BUSHING | 572999 | 0607 |
| FF--SHELL | 573008 | 0607 |

RA PD 367252

Figure 06-9. Instrument cluster—exploded view

| KEY ITEM | PART NO | GROUP |
|-----------|-------------|-------|
| A—NUT | AL-2235 | 0607 |
| B—WASHER | 431680 | 0607 |
| C—WASHER | AL-EX96172 | 0607 |
| D—HARNESS | 7526601 | 0607 |
| E—WASHER | AL-EX100417 | 0607 |
| F—STUD | AL-EX-96034 | 0607 |
| G—CLAMP | AL-26269 | 0607 |
| H—LAMP | 454732 | 0607 |
| J—BODY | 7358620 | 0607 |
| K—WASHER | AL-12X195 | 0607 |
| L—SCREW | AL-8X304 | 0607 |

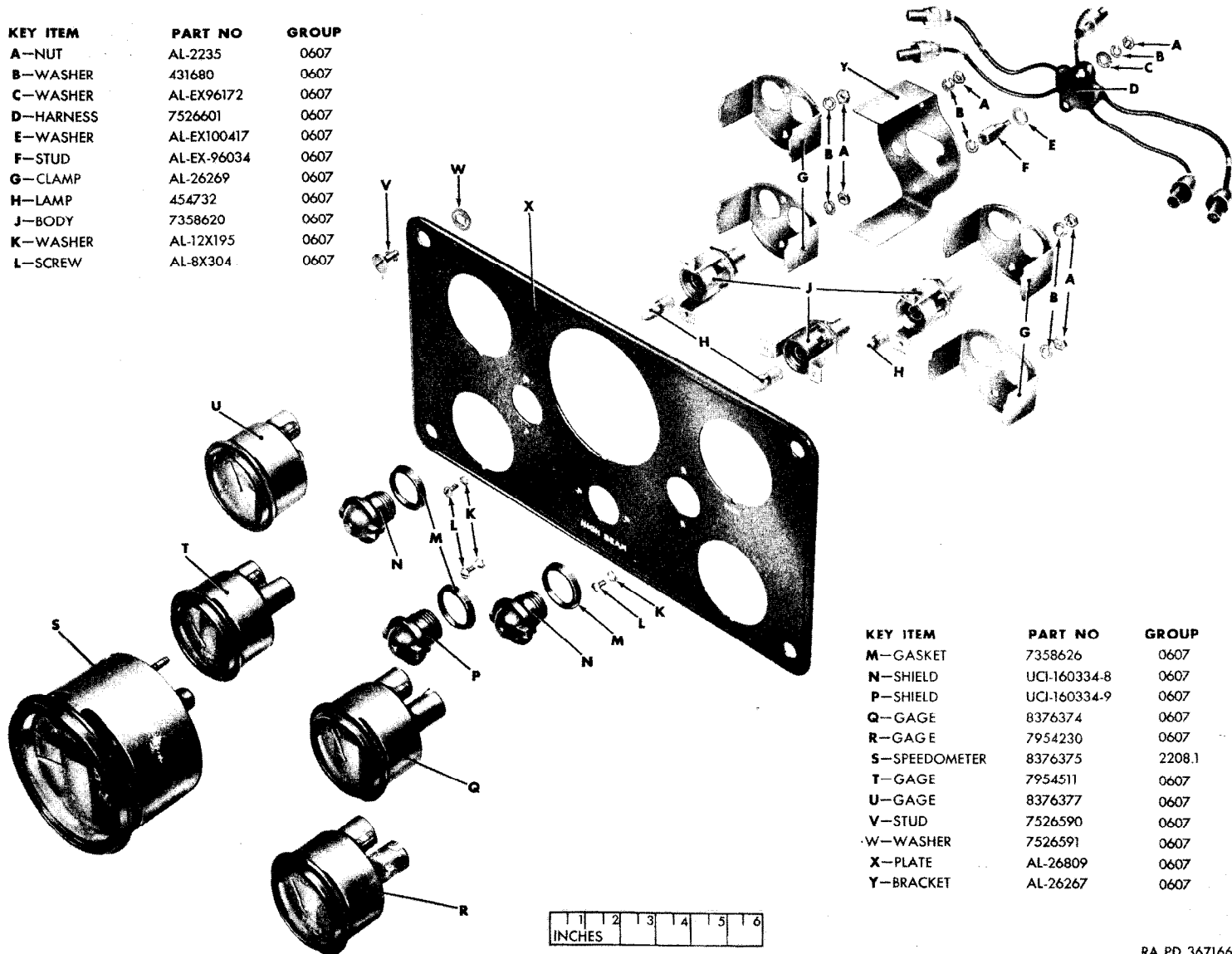

| KEY ITEM | PART NO | GROUP |
|---------------|--------------|--------|
| M—GASKET | 7358626 | 0607 |
| N—SHIELD | UCI-160334-8 | 0607 |
| P—SHIELD | UCI-160334-9 | 0607 |
| Q—GAGE | 8376374 | 0607 |
| R—GAGE | 7954230 | 0607 |
| S—SPEEDOMETER | 8376375 | 2208.1 |
| T—GAGE | 7954511 | 0607 |
| U—GAGE | 8376377 | 0607 |
| V—STUD | 7526590 | 0607 |
| W—WASHER | 7526591 | 0607 |
| X—PLATE | AL-26809 | 0607 |
| Y—BRACKET | AL-26267 | 0607 |

RA PD 367166

Figure 06-10. Instrument cluster (M170)—exploded view

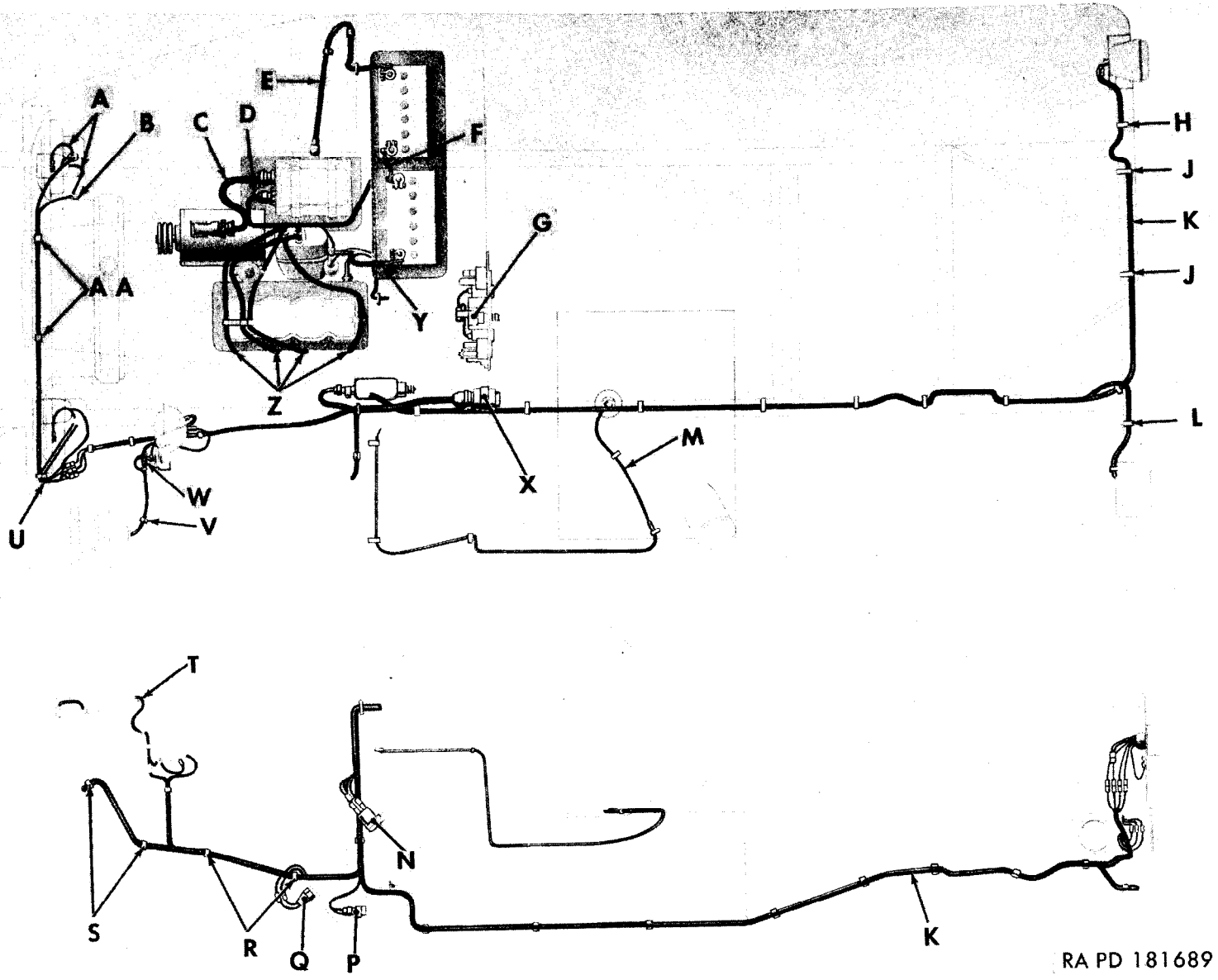

RA PD 181689

Figure 06-11. Wiring system

| <i>Key</i> | <i>Item</i> | <i>Part No.</i> | <i>Group</i> |
|------------|---------------------|-----------------|--------------|
| A | —CABLE, ASSY..... | AL-CB18500 | 0609.1 |
| B | —CLIP..... | 145409 | 0613.1 |
| C | —CABLE, ASSY..... | 8329736 | 0613.1 |
| D | —HARNESS, ASSY..... | 8677431 | 0613.1 |
| E | —CABLE, ASSY..... | 8329664 | 0612 |
| F | —CABLE, ASSY..... | 8329663 | 0612 |
| G | —HARNESS, ASSY..... | 7526600 | 0607 |
| H | —CLIP..... | 7343086 | 0613.1 |
| J | —CLIP..... | 145525 | 0613.1 |
| K | —HARNESS, ASSY..... | 8329662 | 0613.1 |
| L | —CLIP..... | 120527 | 0613.1 |
| M | —CABLE, ASSY..... | 8677520 | 0613.1 |
| N | —SWITCH, ASSY..... | 7728788 | 0608 |
| P | —SWITCH, ASSY..... | 7388813 | 0608 |
| Q | —SWITCH, ASSY..... | 8329689 | 0611 |
| R | —FASTENER..... | 145540 | 0613.1 |
| S | —FASTENER..... | 127753 | 0613.1 |
| T | —CABLE, ASSY..... | AL-CB17891 | 0609.1 |
| U | —CABLE, ASSY..... | AL-CB18499 | 0609.1 |
| V | —CLIP..... | 7047998 | 0613.1 |
| W | —CABLE, ASSY..... | 8677059 | 0613.1 |
| X | —SWITCH, ASSY..... | 7760409 | 0607 |
| Y | —CABLE, ASSY..... | 8329665 | 0612 |
| Z | —CABLE, ASSY..... | 8328449 | 0605 |
| AA | —FASTENER..... | 145411 | 0609.1 |

Figure 06-11. Wiring system—legend

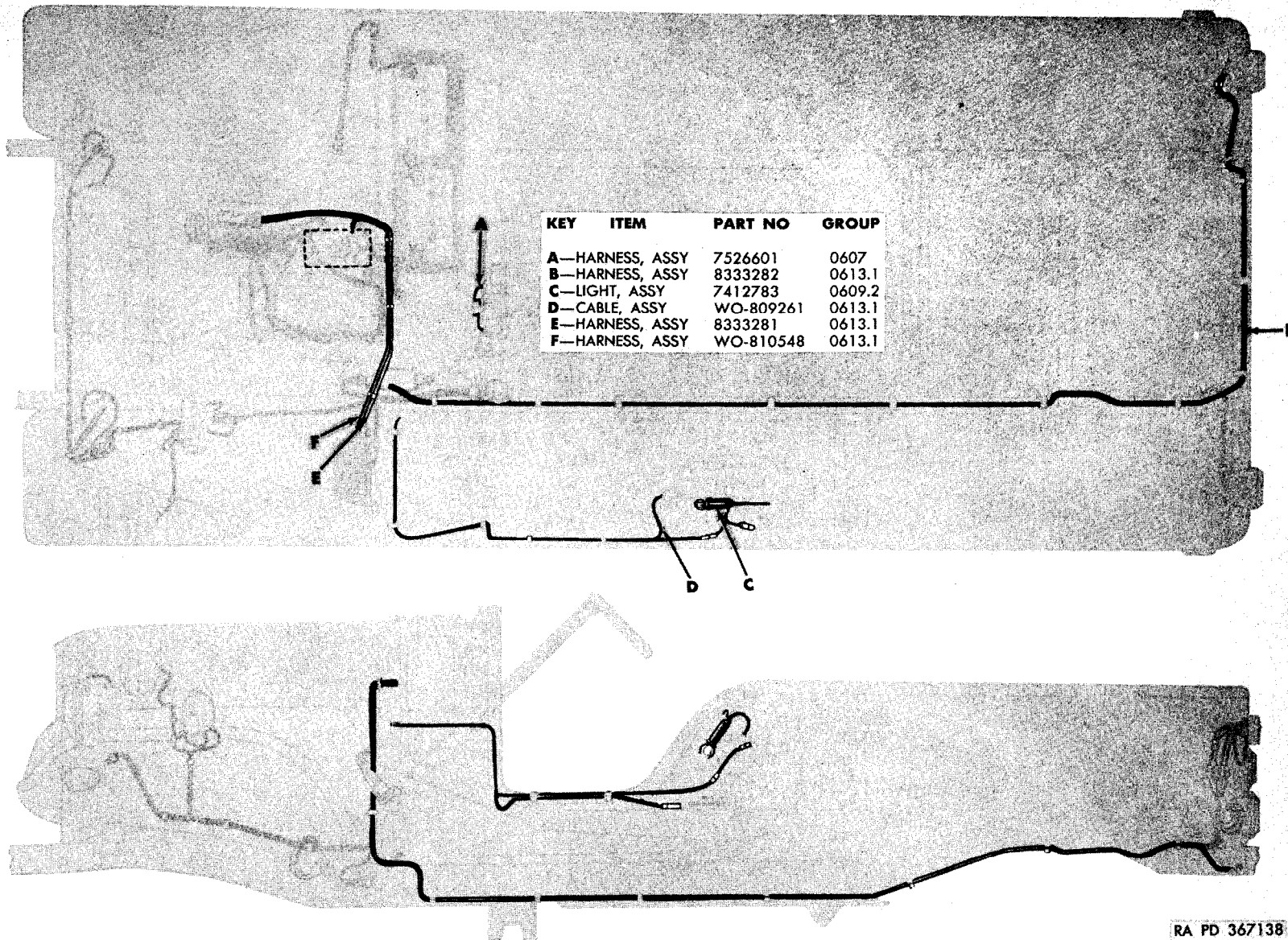

RA PD 367138

Figure 06-12. Wiring system (M170)

| KEY ITEM | PART NO. |
|--------------------|----------|
| A—SCREW | 134225 |
| B—DOOR, ASSY | 7729791 |
| C—GASKET | 7729793 |
| D—LAMP | 190877 |
| E—SCREW | 7729797 |
| F—WASHER | 7729799 |
| G—GROMMET | 502852 |
| H—CONNECTOR, ASSY | 7729796 |
| J—SUPPORT | 7353508 |
| K—PLUG | 7729802 |
| L—HOUSING | 7729792 |
| M—PAD | 7375023 |
| N—NUT W/LOCKWASHER | 271187 |
| P—TERMINAL | 572929 |
| Q—MARKER | 7524649 |
| R—CABLE | 812364 |

NOTE: ALL PARTS LISTED ABOVE ARE IN GROUP 0609.1

ITEMS M AND N NOT PART OF ASSY 7723899

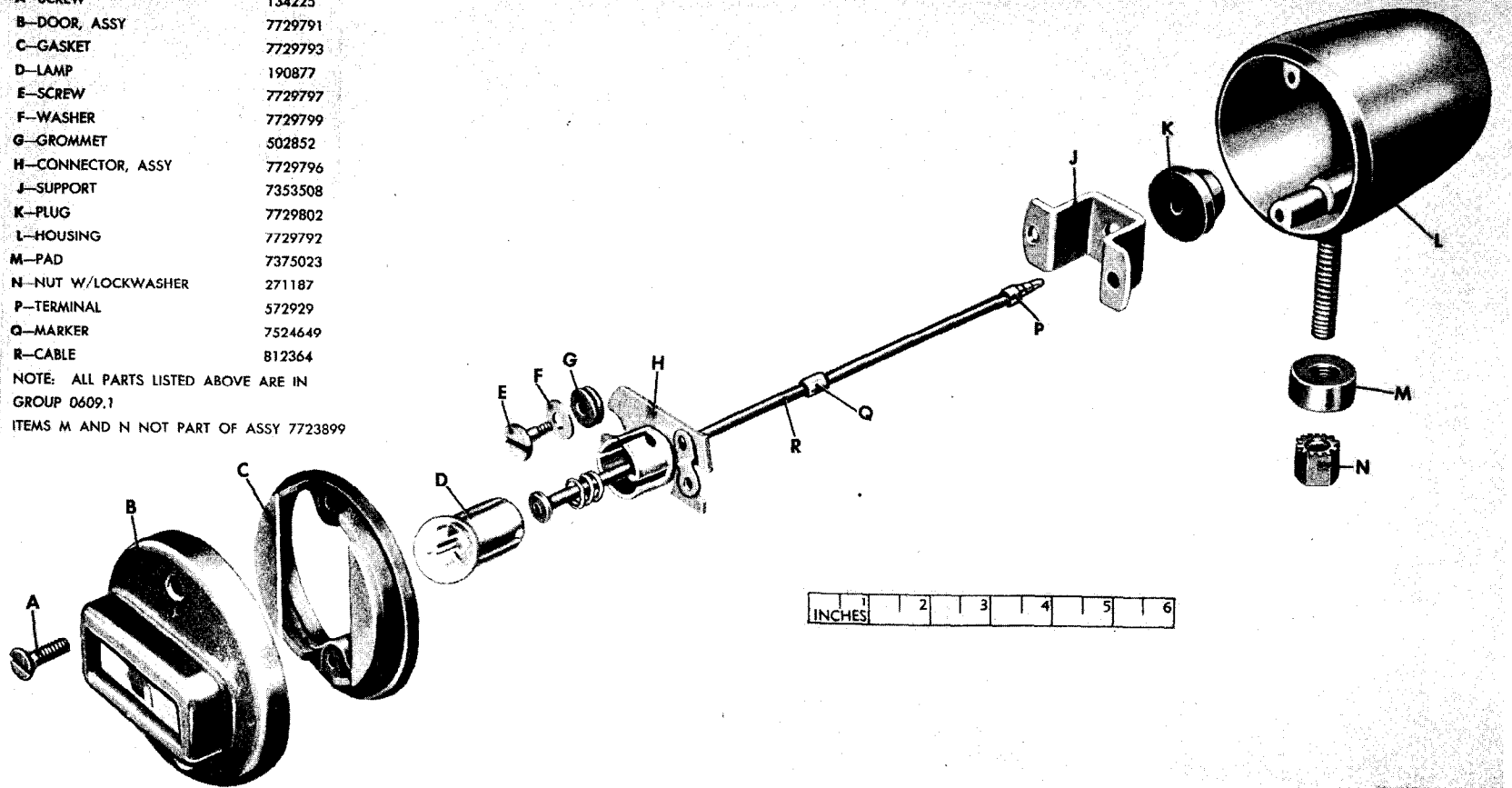

RA PD 367114

Figure 06-13. Blackout marker light, assy (7723899)—exploded view

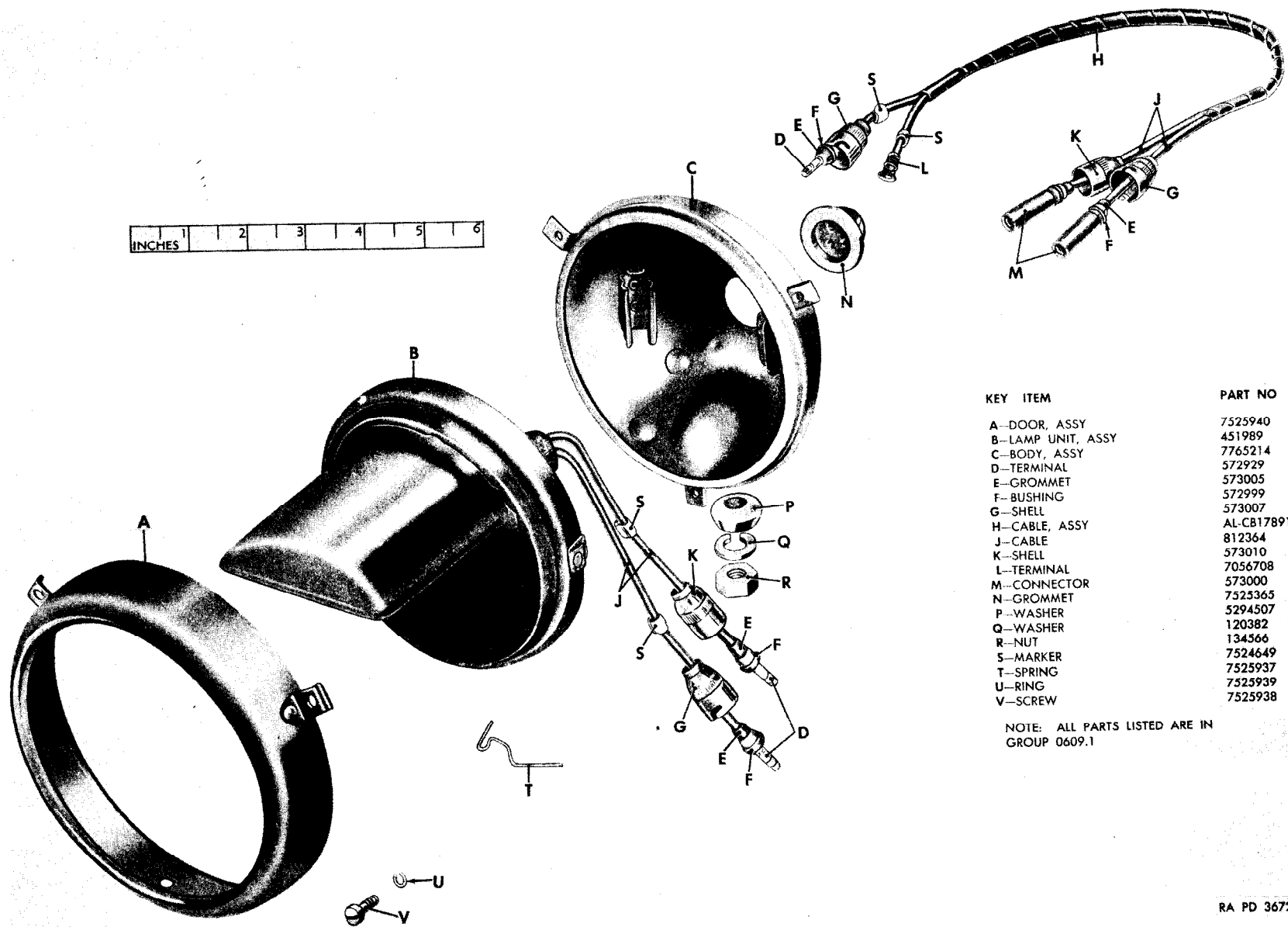

Figure 06-14. Blackout headlight (7760505)—exploded view

| KEY ITEM | PART NO. | KEY ITEM | PART NO. |
|---------------------|------------|---------------------|------------|
| A—DOOR | 7525936 | M—CABLE, ASSY L. H. | AL-CB18499 |
| B—RING | 7538582 | N—TERMINAL | 7056708 |
| C—LAMP UNIT | 7418343 | P—SHELL | 573010 |
| D—MOUNTING | AL-CB17811 | Q—SHELL | 573007 |
| E—SCREW | 7538146 | R—CONNECTOR | 573000 |
| F—HOUSING | AL-CB18510 | S—RIVET | AL-CB17814 |
| G—GROMMET | 7525365 | T—SCREW AND L/W | 454783 |
| H—CABLE, ASSY R. H. | AL-CB18500 | U—SPRING | AL-CB6134 |
| J—TERMINAL | 572929 | V—GROMMET | 573005 |
| K—MARKER | 7524649 | W—BUSHING | 572999 |
| L—CABLE | 812364 | | |

NOTE: ITEMS H, M, AND T NOT PART OF ASSY 7760503
 ALL PARTS LISTED ARE IN GROUP 0609.1

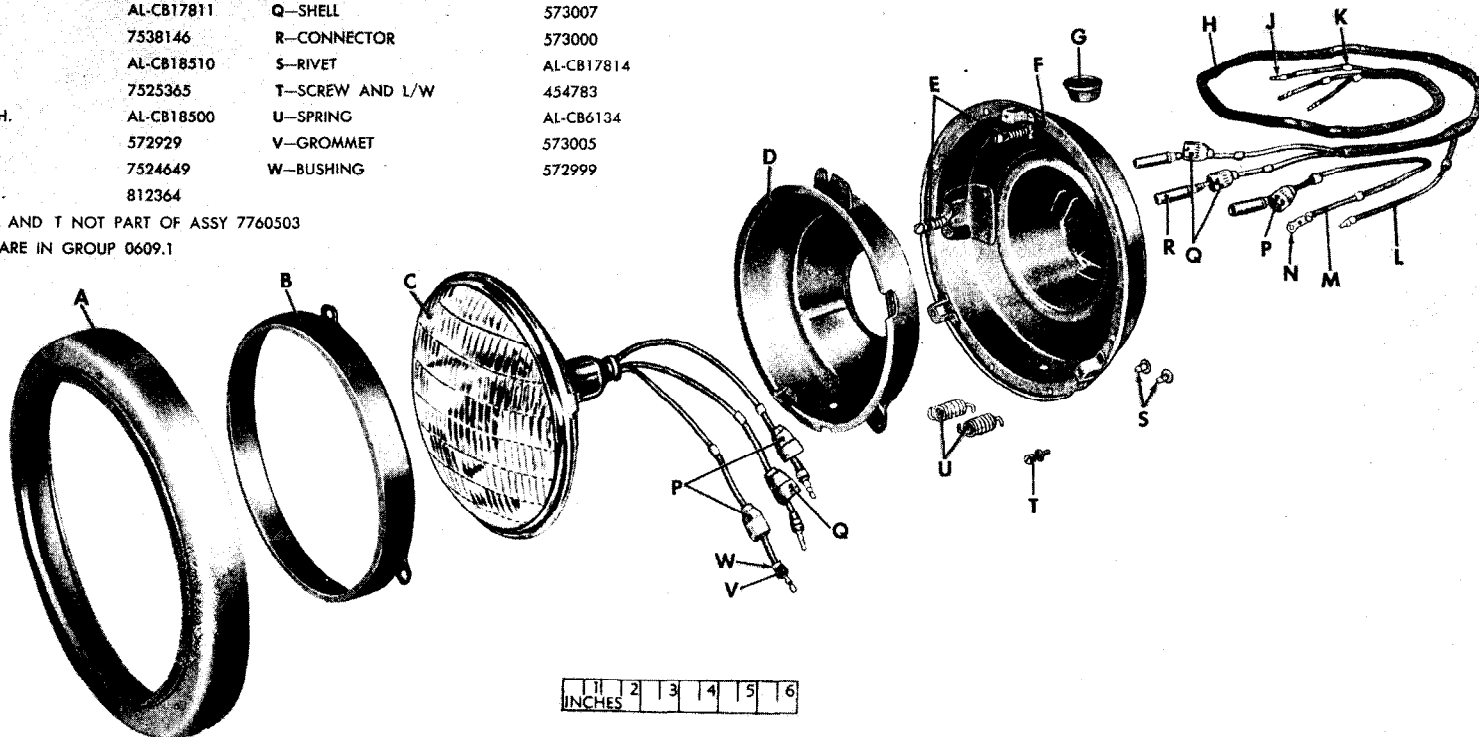

Figure 06-15. Service headlight, assy (7760503)—exploded view

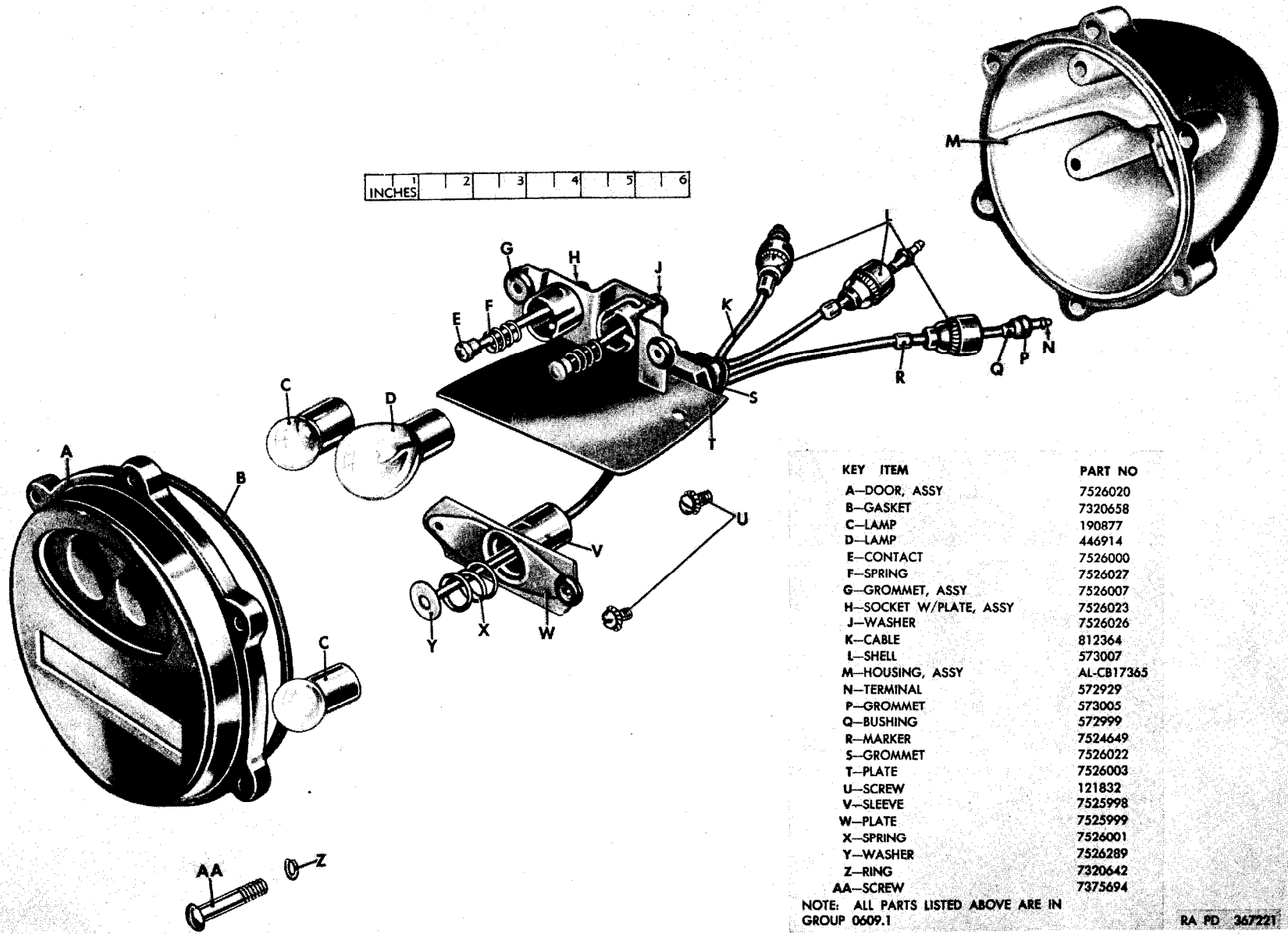
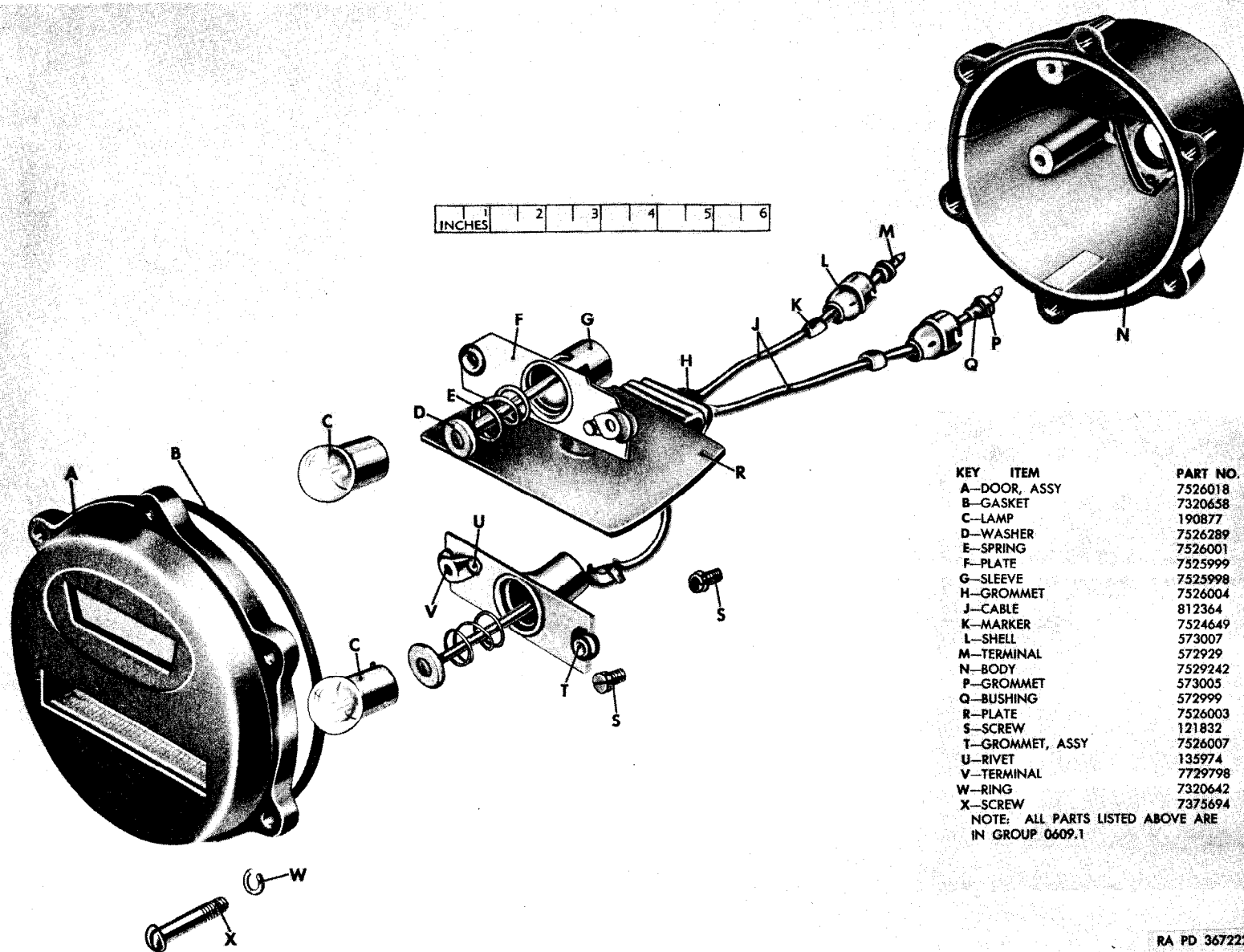
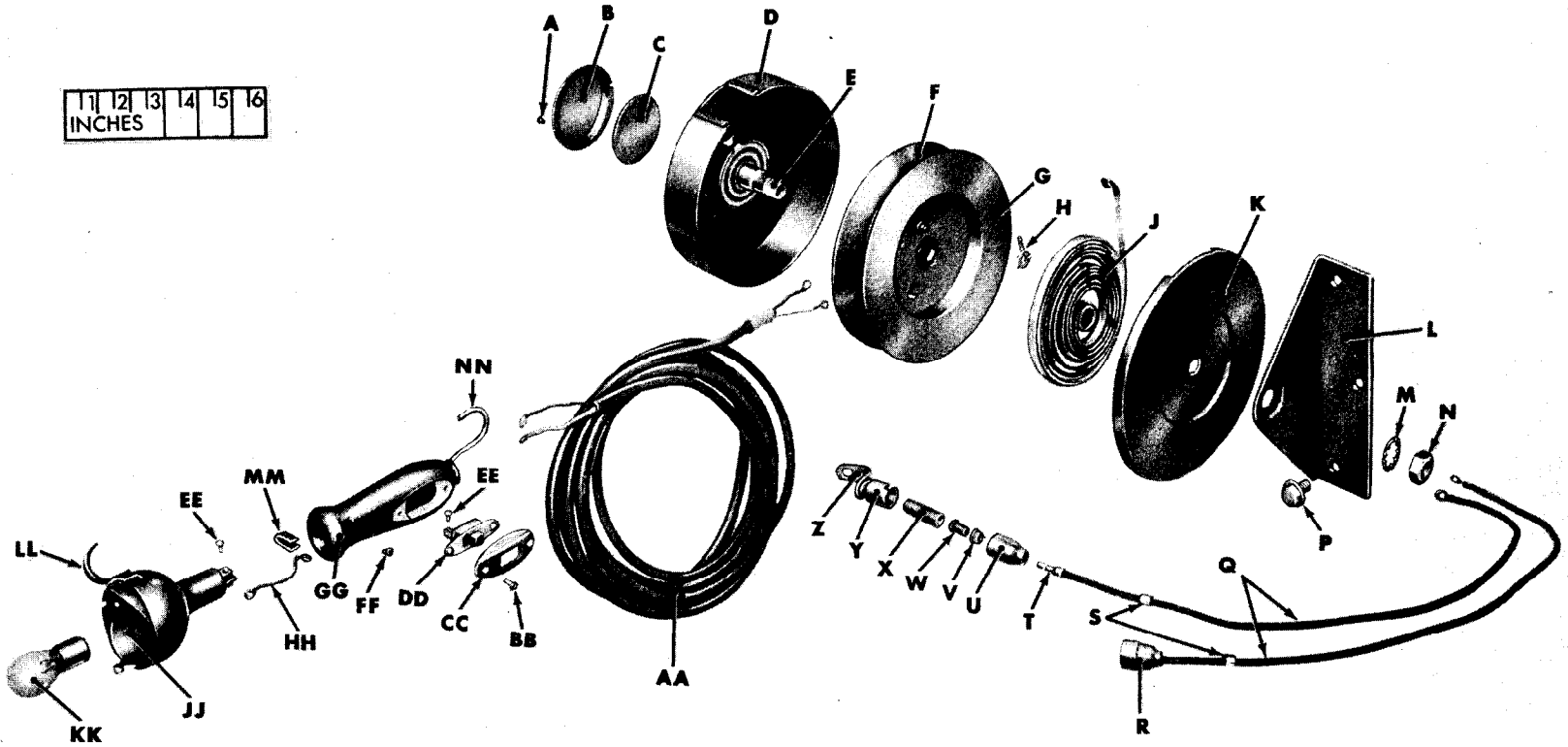
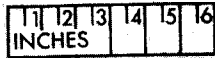

Figure 06-16. Service blackout, tail and stoplight, left (7760507)—exploded view



RA PD 367222

Figure 06-17. Service blackout, tail and stoplight, right (7760506)—exploded view



130

KEY ITEM

- A—SCREW
- B—COVER
- C—SHIELD
- D—CASE, OUTER
- E—SHAFT
- F—PULLEY, LOWER HALF
- G—PULLEY, UPPER HALF
- H—RATCHET
- J—SPRING
- K—LID
- L—BRACKET
- M—WASHER
- N—NUT

PART NO

- 9407716
- RBR-404D4
- RBR-428D4
- RBR-202D3
- RBR-209D3
- RBR-201D3
- RBR-200D3
- RBR-432D3
- RBR-294D4
- RBR-203D3
- RBR-263D4
- RBR-210D4
- RBR-204D4

KEY ITEM

- P—SCREW W/L WASHER
- Q—CABLE
- R—CONNECTOR
- S—MARKER
- T—TERMINAL
- U—SHELL
- V—BUSHING
- W—GROMMET
- X—SLEEVE
- Y—BRACKET
- Z—BRACKET
- AA—CABLE
- BB—SCREW

PART NO

- 7372885
- 812364
- 7760598
- 7524649
- 572929
- 573010
- 572999
- 573005
- 573000
- 7726808
- 7726804
- 7732849
- RBR-274D4

KEY ITEM

- CC—PLATE
- DD—SWITCH
- EE—SCREW
- FF—SCREW
- GG—HANDLE
- HH—WIRE
- JJ—REFLECTOR
- KK—LAMP
- LL—HOOK
- MM—RING
- NN—HOOK

PART NO

- RBR-273D4
- RBR-264D4
- 451785
- 145230
- HC-DL-12-3
- RBR-265D4
- HC-DL-12-2
- 193048
- HC-DL-16-5
- RBR-276D4
- HC-DL-16-4

NOTE: ALL PARTS LISTED ARE IN GROUP 0609.2.

RA PD 367156

Figure 06-18. Reel lamp (M170)—exploded view

| (1) ILLUSTRATION NO. | (2) REFERENCE SYMBOLS | (3) FEDERAL STOCK NO. | (4) ORDNANCE STOCK NO. | (5) MFR'S PART NO. | (6) ORDNANCE PART NO. | (7) DESCRIPTION | (8) QUANTITY INCORPORATED IN UNIT | (9) UNIT OF ISSUE |
|---|--------------------------|---------------------------|------------------------------|--|--------------------------|---|--------------------------------------|----------------------|
| GROUP 06—ELECTRICAL SYSTEM | | | | | | | | |
| 0601.1—GENERATOR (24-VOLT) (AUTO-LITE) | | | | | | | | |
| | | 2920-832-7721 | G741-8327721 | AL-GHA15 CC-1273439 WO-118821 | 8327721 | ARM, brush..... | 2 | ea |
| 06-1 | | 6115-737-4853 | G741-7374853 | AL-GHA2006FT WO-118812 | 7374853 | ARMATURE, assy..... | 1 | ea |
| 06-1 | H12 | | H012-0712125 | | 712125 | BEARING, ball, MIL-STD-CODE 111-01703-8438 (rad, SR, med, non-loading groove, 1 seal, 0.6693 ID, 1.8504 OD, 0.5512 width) (drive end) | 1 | ea |
| 06-1 | H12 | | H012-0712128 | | 712128 | BEARING, ball, MIL-STD-CODE 117-01715-5070 (rad, SR, non-loading groove, narrow outer race, 1 seal, 1 shield, 0.6693 bore, 1.5748 OD, 0.5630 overall width) (commutator end) | 1 | ea |
| | H1 | 2920-737-5388 042-3571 | G740-7375388 H101-0423571 | WO-801247 | 7375388 423571 | BRACE, adj, belt tension..... | 1 | ea |
| | H1 | 5305-360-8319 012-0369 | G503-7371188 H001-4167601 | WO-A1468 | 7371188 120369 | BOLT, integral lock washer, ext-teeth type, hex-hd, S, cd- or zn-pltd, $\frac{3}{8}$ -16NC-2 x 1 | 1 | ea |
| | H1 | 5310-012-0394 | H001-7043741 | | 120394 | BOLT, shoulder, hex-hd, S, $\frac{3}{8}$ -24NF x $\frac{7}{8}$ | 1 | ea |
| | H1 | 5310-012-0382 | H001-7025741 | | 120382 | NUT, plain, hex, reg, S, cd- or zn-pltd, $\frac{3}{8}$ -24NF-2..... | 1 | ea |
| 06-1 | | 5975-737-4852 | G741-7374852 | AL-GHA1012 AL-GHA2012S WO-118807 | 7374852 | WASHER, FLAT, S, cd- or zn-pltd, $\frac{3}{8}$ in..... | 1 | ea |
| 06-1 | | | G742-7716690 | AL-GHA1012 AL-XA777 WO-118819 | 7716690 | WASHER, lock, S, cd- or zn-pltd, $\frac{3}{8}$ in..... | 1 | ea |
| 06-1 | H1 | 013-1966 | H101-0131966 | | 131966 | BRUSH | 2 | ea |
| 06-1 | | 2920-737-4886 | G741-7374886 | AL-GHA1004S WO-118805 | 7374886 | BRUSH SET..... | 1 | ea |
| 06-1 | | 2920-737-4749 | G741-7374749 | AL-GHA1052 WO-118806 | 7374749 | Composed of: 2 BRUSH | | |
| 06-1 | | 2920-737-4748 | G741-7374748 | AL-GHA53 WO-118835 | 7374748 | ELBOW, 90 deg, receptacle mtg..... | 1 | ea |
| 06-1 | | 2920-737-4851 | G741-7374851 | AL-GHA2051S WO-118803 | 7374851 | SCREW, mach, fil-hd, S, cd- or zn-pltd, No. 8-32NC- 2A x $\frac{1}{16}$ | 4 | ea |
| 06-1 | | 771-6562 | G244-7716562 | AL-XA767 WO-118769 | 7716562 | END BRACKET, brush, w/SPRINGS and brush HOLDER, assy (w/o BRUSHES) | 1 | ea |
| | | | | | | END BRACKET, commutator end..... | 1 | ea |
| | | | | | | END BRACKET, drive end..... | 1 | ea |
| | | | | | | FRAME, w/field COILS, assy..... | 1 | ea |
| | | | | | | GASKET, flat, fbr, 1 $\frac{5}{8}$ sq, 1 $\frac{3}{8}$ ID, 4 No. 10 screw holes (receptacle mtg) | 2 | ea |

| (1) ILLUSTRATION NO. | (2) REFERENCE SYMBOLS | (3) FEDERAL STOCK NO. | (4) ORDNANCE STOCK NO. | (5) MFR'S PART NO. | (6) ORDNANCE PART NO. | (7) DESCRIPTION | (8) QUANTITY INCORPORATED IN UNIT | (9) UNIT OF ISSUE | |
|--|--------------------------|---------------------------|------------------------------|----------------------------|---|--|---|----------------------|----|
| GROUP 06—ELECTRICAL SYSTEM—Continued | | | | | | | | | |
| 0601.1—GENERATOR (24-VOLT) (AUTO-LITE) —Continued | | | | | | | | | |
| 06-1 01-2, 06-1 | | 2920-737-4862 | G741-7374862 | AL-GHA46 WO-118833 | 7374862 | GEAR, drive, oil slinger (superseded by GEAR 7412438) | 1 | ea | |
| | | | G740-7412438 | | 7412438 | GEAR, drive, oil slinger (supersedes GEAR 7374862) | 1 | ea | |
| | | | | AL-GHA4802BUT WO-801238 | 8673350 | GENERATOR, w/PULLEY, assy (optional w/GENERATOR DR-1922304—subgroup 0601.3) | 1 | ea | |
| | | | 5305-737-5174 | G740-7375174 | WO-649818 | 7375174 | BOLT, shoulder, hex-hd, S, 1/16-20NF-3 x 2 1/4 (superseded by BOLT WO-809626) | 2 | ea |
| | | | | | WO-809626 | | BOLT, shoulder, hex-hd, S, 1/16-20NF-3 x 2.44 (supersedes BOLT 7375174) | 2 | ea |
| | | H1 | | H101-0442830 | | 442830 | NUT, lock, hex, 1/16-20NF | 2 | ea |
| | | H1 | 5310-012-0395 | H001-7043771 | | 120395 | WASHER, FLAT, light series, S, cd- or zn-pltd, 1/16 in. | 2 | ea |
| | | H1 | 5310-012-0396 | H001-7043801 | | 120396 | WASHER, FLAT, S, cd- or zn-pltd, 1 1/2 ID, 1 1/8 OD | 2 | ea |
| | | H1 | 017-8571 | H001-7124761 | | 178571 | WASHER, lock, int-ext-teeth, S, cd- or zn-pltd, 1/16 x 1.070 (1.045 to 1.070 OD) (generator to support to front engine plate) | 2 | ea |
| | | | 6115-737-4750 | G741-7374750 | AL-GHA4802UT WO-118958 AL-GHA2052 | 7374750 | GENERATOR, w/o PULLEY, assy (optional w/GENERATOR 7355736—subgroup 0601.3) | 1 | ea |
| 06-1 | H1 | 013-2119 | H001-5127361 | | 132119 | HEAD, commutator end, w/BRUSH and BEARING, assy | 1 | ea | |
| 06-1 | H1 | 013-2138 | H101-0132138 | | 132138 | BOLT, MACHINE, fil-hd, S, cd- or zn-pltd, No. 10-32NF-2A x 5/8 | 4 | ea | |
| | | | | AL-GHA1053 | | SCREW, mach, fil-hd, S, cd- or zn-pltd, No. 10-32NF-2A x 1 1/4 | 2 | ea | |
| 06-1 | H1 | 013-2128 | H101-0132128 | | 132128 | HEAD, drive end, w/BEARING, assy | 1 | ea | |
| | | | | | | SCREW, mach, fil-hd, S, cd- or zn-pltd, No. 10-32NF-2A x 7/8 | 6 | ea | |
| 06-1 | H1 | 5330-737-5175 012-4545 | G740-7375175 H001-0518012 | WO-649817 | 7375175 124545 | INSULATOR, ru, 33/64 ID, 1 1/8 OD, 1 5/32 thk (mtg support) | 2 | ea | |
| 06-1 | H2 | | H002-0501234 | | 501234 | KEY, Woodruff, S, alloy, pl-fin, size No. 5, 1/8 x 5/8 (drive end) | 1 | ea | |
| | | | | | | PACKING, "O" ring, class B material, (high flexibility) 1/8 thk, 1 3/8 ID, 1 5/8 OD (drive end bearing inner retainer) | 1 | ea | |
| | H2 | | H002-0546886 | | | PACKING, "O" ring, class B material, (high flexibility) 1/8 thk, 5 ID, 5 1/8 OD (supersedes PACKING 7375330) (superseded by PACKING 7412437) | 1 | ea | |

| | | | | | | | | |
|------|----|---------------|--------------|--|---------|--|---|----|
| | | 5330-737-5330 | G740-7375330 | AL-XA744H WO-118822 | 7375330 | PACKING, "O" ring, 5 $\frac{7}{16}$ OD (commutator end head to frame) (superseded by PACKING H002-0546886) | 1 | ea |
| 06-1 | | 5330-741-2437 | G740-7412437 | AL-XA744F WO-119116 | 7412437 | PACKING, "O" ring, 5 $\frac{7}{16}$ OD (drive end head to frame) (supersedes PACKING H002-0546886) | 2 | ea |
| 06-1 | H2 | | H002-7375329 | | 7375329 | PACKING, "O" ring, gasket, $\frac{1}{2}$ ID, $\frac{5}{8}$ OD, 0.062 thk (drive end head oil plug) | 1 | ea |
| 06-1 | H2 | | H002-7375328 | | 7375328 | PACKING, "O" ring, gasket, 1.875 ID, 2 OD, 0.062 thk (drive end outer retainer) | 1 | ea |
| 06-1 | | 5315-737-4861 | G741-7374861 | AL-GHA42 WO-118832 AL-GHA1004 | 7374861 | PIN, pivot, oil slinger | 1 | ea |
| 06-1 | H1 | 013-2110 | H001-5127341 | | 132110 | PLATE, brush, w/BRUSHES, SPRING, and brush HOLDER, assy | 1 | ea |
| 06-1 | | 4730-737-4854 | G741-7374854 | AL-GHA35 WO-118826 | 7374854 | SCREW, mach, fil-hd, S, cd- or zn-pltd, No. 10-32NF-2A x $\frac{7}{16}$ | 4 | ea |
| 06-1 | H6 | 050-0718 | H006-0500718 | | 500718 | PLUG, oil, drive end head | 1 | ea |
| 06-1 | | 2805-737-5071 | G740-7375071 | AL-SP992 WO-118824 | 7375071 | PLUG, pipe, hex-socket, hdl, S, cd- or zn-pltd, $\frac{1}{8}$ -27NPT (drive end head) | 1 | ea |
| 06-1 | H1 | 012-5043 | H101-0125043 | | 125043 | PULLEY, drive | 1 | ea |
| 06-1 | H1 | 012-1224 | H101-0121224 | | 121224 | NUT, castellated, hex, lt, s-fin, S, cd- or zn-pltd, $\frac{1}{2}$ -20NF-2 | 1 | ea |
| 06-1 | H1 | 5310-012-0384 | H001-7025801 | | 120384 | PIN, cotter, S, cd- or zn-pltd, $\frac{3}{32}$ x 1 | 1 | ea |
| 06-1 | | 5930-738-8319 | G260-7388319 | AL-XA776 SCI-10-42222-2S WO-118818 | 7388319 | WASHER, lock, med, S, cd- or zn-pltd, $\frac{1}{2}$ in | 1 | ea |
| 06-1 | H1 | 013-1970 | H001-5125851 | | 131970 | RECEPTACLE, wiring harness, assy | 1 | ea |
| 06-1 | | 2920-737-4858 | G741-7374858 | AL-GHA39 WO-118829 | 7374858 | SCREW, mach, fil-hd, S, cd- or zn-pltd, No. 8-32NC-2A x $\frac{1}{2}$ | 4 | ea |
| 06-1 | | 2920-737-4855 | G741-7374855 | AL-GHA36 WO-118827 | 7374855 | RETAINER, drive end head bearing, inner | 1 | ea |
| 06-1 | H1 | 013-1970 | H001-5125851 | | 131970 | RETAINER, drive end head bearing, outer | 1 | ea |
| 06-1 | H1 | 013-1958 | H001-5125821 | | 131958 | SCREW, mach, fil-hd, S, cd- or zn-pltd, No. 8-32NC-2A x $\frac{1}{2}$ | 4 | ea |
| 06-1 | | 2920-737-4860 | G741-7374860 | AL-GHA41 WO-118831 | 7374860 | SCREW, mach, fil-hd, S, cd- or zn-pltd, No. 8-32NC-2 x $\frac{5}{16}$ | 2 | ea |
| 06-1 | | | G741-8332226 | AL-X3099 WO-118939 | 8332226 | RETAINER, drive end head felt washer | 1 | ea |
| 06-1 | | | G741-7374863 | AL-GHA47 WO-118834 | 7374863 | SCREW, hex-hd, br, Sems type, No. 8-32NC x $\frac{1}{4}$ (brush lead cable) | 2 | ea |
| 06-1 | | | G758-8332522 | AL-GHA65 WO-120158 | 8332522 | SEAL, oil, drive end head bearing | 1 | ea |
| 06-1 | | 2920-737-4746 | G741-7374746 | AL-GHA1044 WO-118813 | 7374746 | SLEEVE, elec (field lead) | 1 | ea |
| 06-1 | | | | | | SLINGER, oil, fiber, drive end head | 1 | ea |

0601.1

| (1) ILLUSTRATION NO. | (2) REFERENCE SYMBOLS | (3) FEDERAL STOCK NO. | (4) ORDNANCE STOCK NO. | (5) MFR'S PART NO. | (6) ORDNANCE PART NO. | (7) DESCRIPTION | (8) QUANTITY INCORPORATED IN UNIT | (9) UNIT OF ISSUE |
|--|--------------------------|---------------------------|------------------------------|-------------------------|--------------------------|--|--------------------------------------|----------------------|
| GROUP 06—ELECTRICAL SYSTEM—Continued | | | | | | | | |
| 0601.1—GENERATOR (24-VOLT) (AUTO-LITE) | | | | | | | | |
| —Continued | | | | | | | | |
| 06-1 | | 2920-737-4856 | G741-7374856 | AL-GHA37 WO-118823 | 7374856 | SPACER, armature shaft, drive end..... | 1 | ea |
| | | 5340-734-7573 | G741-7347573 | AL-GAR221A WO-118820 | 7347573 | SPRING, brush arm (plate)..... | 2 | ea |
| | H1 | 2920-737-5389 022-7785 | G740-7375389 H101-0227785 | WO-649816 | 7375389 227785 | SUPPORT, mounting..... | 1 | ea |
| | H1 | 5310-012-0382 | H001-7025741 | | 120382 | BOLT, mach, hex-hd, S, cd- or zn-pltd, $\frac{3}{8}$ -16NC-2 x $\frac{1}{2}$ | 2 | ea |
| 06-1 | | 5310-737-4857 | G741-7374857 | AL-GHA38 WO-118828 | 7374857 | WASHER, lock, med, reg, S, cd- or zn-pltd, $\frac{3}{8}$ in..... | 2 | ea |
| | | | | | | WASHER, drive end head outer retainer..... | 1 | ea |
| 06-1 | | 5330-737-4859 | G741-7374859 | AL-GHA40 WO-118830 | 7374859 | WASHER, felt, drive end head..... | 1 | ea |
| 0601.3—GENERATOR (24-VOLT) (DELCO-REMY) | | | | | | | | |
| 06-2 | | 2920-741-3317 | G741-7413317 | DR-1921762 WO-119484 | 7413317 | ARMATURE..... | 1 | ea |
| 06-2 | H12 | | H012-7538747 | | 7538747 | BEARING, ball, SR (rad, dble seal, 0.6693 bore, 1.5748 OD, 0.6536 width) (commutator end head) | 1 | ea |
| 06-2 | H12 | | H012-7413226 | | 7413226 | BEARING, ball, SR, (rad, dble seal, 0.7874 bore, 1.8504 OD, 0.5512 width) (drive end head) | 1 | ea |
| 06-2 | | 2920-737-5388 | G740-7375388 | WO-801247 | 7375388 | BRACE, adj, belt tension..... | 1 | ea |
| 06-2 | H1 | 042-3571 | H101-0423571 | | 423571 | BOLT, integral lock washer, hex-hd, ext-teeth, S, cd- or zn-pltd, $\frac{3}{8}$ -16NC-2 x 1 | 1 | ea |
| 06-2 | | 5305-360-8319 | G503-7371188 | WO-A1468 | 7371188 | BOLT, shoulder, hex-hd, S, $\frac{3}{8}$ -24NF x $\frac{7}{8}$ | 1 | ea |
| 06-2 | H1 | 012-0369 | H001-4167601 | | 120369 | NUT, PLAIN, hex, S, cd- or zn-pltd, $\frac{3}{8}$ -24NF-2..... | 1 | ea |
| 06-2 | H1 | 5310-012-0394 | H001-7043741 | | 120394 | WASHER, FLAT, lt, S, cd- or zn-pltd, $\frac{3}{8}$ in..... | 1 | ea |
| | H1 | | H001-7021861 | | 138549 | WASHER, lock, int-teeth, S, cd- or zn-pltd, $\frac{1}{2}$ in. (under head of BOLT 7371188) | 1 | ea |
| 06-2 | H1 | 5310-012-0382 | H001-7025741 | | 120382 | WASHER, LOCK, med, S, cd- or zn-pltd, $\frac{3}{8}$ in..... | 1 | ea |
| 06-2 | | | G742-7538749 | DR-1906927 WO-118885 | 7538749 | BRUSH..... | 2 | ea |
| 06-2 | H1 | | H101-0453292 | | 453292 | SCREW, MACHINE, pan-hd, S, cd- or zn-pltd, No. 6-32NC-2A x $\frac{1}{4}$ | 2 | ea |
| 06-2 | H1 | 013-1044 | H001-7025561 | | 131044 | WASHER, LOCK, med, S, cd- or zn-pltd, No. 6..... | 2 | ea |
| | | | | DR-1916417 | | BRUSH, collector..... | 1 | ea |

134

| | | | | | | | | |
|------|----|---------------|--------------|--|---|---|--------|----------|
| 06-2 | | | G742-7538784 | DR-1916415 WO-118886 | 7538784 | BRUSH, collector, drive end, head bearing, w/SPRING, assy Composed of: 1 BRUSH 1 SPRING | 1 | ea |
| 06-2 | | | G742-7538753 | DR-1916417 DR-1916416 DR-1917894 | 7538753 | BUSHING, brush plate | 2 | ea |
| 06-2 | | 5910-256-9728 | G742-7538751 | DR-1916321 WO-118887 | 7538751 | CABLE, connecting, brush No. 18, ins, 5 $\frac{3}{4}$ lg. | 1 | ea |
| 06-2 | | | G742-7538751 | DR-1916209 WO-118888 | 7538751 | CAPACITOR, armature circuit | 1 | ea |
| | | 2920-570-1238 | G742-5701238 | DR-1916646 WO-119016 | 7388377 | CLIP, terminal | 1 | ea |
| | | | G742-5701238 | DR-1916773 WO-118889 | 5701238 | COIL SET, field Composed of: 8 SCREW | 1 | ea |
| 06-2 | | 2920-753-8754 | G742-7538754 | DR-1916322 WO-118890 | 453308 7538777 7538762 7538763 7538761 7538754 | 1 WINDING, generator field, lower left 1 WINDING, generator field, lower right 1 WINDING, generator field, upper left 1 WINDING, generator field, upper right COLLAR, armature, drive end | 1 | ea |
| 06-2 | | | G742-7716690 | DR-1916150 WO-118891 | 7716690 | ELBOW, 90 deg, No. 27 shell wtrprf connector (terminal receptacle) | 1 | ea |
| 06-2 | H1 | 013-1987 | H001-5125891 | | 131987 | BOLT, MACHINE, fil-hd, S, cd- or zn-pltd, No. 8-32NC-2 x 1 | 4 | ea |
| 06-2 | H1 | | H101-0453299 | | 453299 | WASHER, lock, med, S, cd-pltd, No. 8 | 4 | ea |
| 06-2 | | | | DR-1921772 WO-119544 | | FRAME, field coil, w/terminal BRACKET | 1 | ea |
| 06-2 | | 2920-739-1018 | G742-7391018 | DR-1916320 WO-118892 | 7391018 | GASKET, annular, cop and asb, oval sec, 1 $\frac{3}{8}$ ID, 1 $\frac{5}{8}$ OD, $\frac{3}{32}$ thk (housing plug) | 1 | ea |
| 06-2 | | 771-6562 | G244-7716562 | DR-1916211 WO-118894 | 7716562 | GASKET, fl, fiber, 1 $\frac{3}{8}$ sq, 1 $\frac{3}{8}$ ID, 4 No. 10 screw holes (receptacle mtg) | 3 | ea |
| 06-2 | | 2920-753-8759 | G742-7538759 | DR-1916135 WO-118893 | 7538759 | GASKET, ru, 1 $\frac{5}{8}$ ID, 3 $\frac{1}{4}$ OD, $\frac{1}{32}$ thk (commutator end head bearing retaining plate) | 1 | ea |
| | | 2910-737-5174 | G740-7375174 | DR-1922304 WO-806072 | | GENERATOR, 24 v, wtrprf, w/PULLEY, assy (optional w/GENERATOR 8673350 subgroup 0601.1) | 1 | ea |
| | H1 | 012-0370 | H001-4167641 | WO-649818 | 7375174 120370 | BOLT, SHOULDER, hex-hd, $\frac{1}{16}$ -20NF-3 x 2 $\frac{1}{4}$ NUT, PLAIN, HEXAGON, lt, s-fin, S, cd- or zn-pltd, $\frac{1}{16}$ -20NF-2 | 2 2 | ea ea |
| | H1 | 012-0395 | H001-7043771 | | 120395 | WASHER, FLAT, lt, S, cd- or zn-pltd, $\frac{1}{16}$ in. | 2 | ea |
| | H1 | 5310-012-0396 | H001-7043801 | | 120396 | WASHER, FLAT, S, cd- or zn-pltd, $\frac{1}{2}$ in. | 2 | ea |
| | H1 | 5310-013-6857 | H001-7017711 | | 136857 | WASHER, LOCK, ext-teeth, S, cd- or zn-pltd, $\frac{1}{16}$ in. | 2 | ea |
| 06-2 | | 2920-735-5736 | G741-7355736 | DR-1117495 WO-119547 | 7355736 | GENERATOR, 24 v, wtrprf, w/o PULLEY, assy (optional w/GENERATOR 7374750 subgroup 0601.1) | 1 | ea |
| 06-2 | | 2920-753-8757 | G742-7538757 | DR-1916107 WO-118896 | 7538757 | HEAD, commutator end | 1 | ea |

| (1) ILLUSTRATION NO. | (2) REFER- ENCE SYMBOLS | (3) FEDERAL STOCK NO. | (4) ORDNANCE STOCK NO. | (5) MFR'S PART NO. | (6) ORDNANCE PART NO. | (7) DESCRIPTION | (8) QUANTITY INCOR- PORATED IN UNIT | (9) UNIT OF ISSUE |
|---|----------------------------------|-----------------------------|------------------------------|-------------------------|---|--|---|----------------------------|
| GROUP 06—ELECTRICAL SYSTEM—Continued | | | | | | | | |
| 0601.3—GENERATOR (24-VOLT) (DELCO-REMY) —Continued | | | | | | | | |
| | | | | DR-1921764 WO-119546 | | HEAD, commutator end, assy..... | 1 | ea |
| | | | | | 7538749 7538757 7373350 8344313 7413318 453292 7413315 7538767 131044 453307 | Composed of: 2 BRUSH 1 HEAD 2 HOLDER 1 LEAD 1 PLATE 2 SCREW 2 SPRING 2 WASHER 2 WASHER SCREW, mach, fil-hd, S, cd- or zn-pltd, No. 12-24NC x 1 ¹ / ₁₆ | | |
| 06-2 | H1 | 753-8782 | H101-0453307 | | | SCREW, mach, fil-hd, S, cd- or zn-pltd, No. 12-24NC x 1 ¹ / ₁₆ | 4 | ea |
| 06-2 | H1 | 044-6161 | H101-0446161 | | 446161 | WASHER, FLAT, lt, S, cd- or zn-pltd, 3 ¹ / ₁₆ in..... | 4 | ea |
| 06-2 | H1 | | H101-0453708 | | 453708 | WASHER, lock, lt, S, cd- or dichromate-pltd, No. 12..... | 4 | ea |
| 06-2 | | 2920-753-8756 | G742-7538756 | DR-1916106 WO-118897 | 7538756 | HEAD, drive end..... | 1 | ea |
| 06-2 | H1 | 753-8782 | H101-0453307 | | 453307 | SCREW, mach, fil-hd, S, cd-pltd, No. 12-24NC x 1 ¹ / ₁₆ | 4 | ea |
| 06-2 | H1 | 044-6161 | H101-0446161 | | 446161 | WASHER, FLAT, lt, S, cd- or zn-pltd, 3 ¹ / ₁₆ in..... | 4 | ea |
| 06-2 | H1 | | H101-0453708 | | 453708 | WASHER, lock, lt, S, cd- or dichromate-pltd, No. 12..... | 4 | ea |
| 06-2 | | 2920-358-6304 | G742-7373350 | DR-1904514 WO-118899 | 7373350 | HOLDER, brush..... | 2 | ea |
| | | | | DR-1904516 | | HOLDER, brush, plate..... | 2 | ea |
| | | | | DR-1916133 | | INSULATOR, brush plate..... | 1 | ea |
| | | | | DR-1916134 | | INSULATOR, brush plate..... | 1 | ea |
| | | 5970-737-4865 | G741-7374865 | DR-1917993 WO-118900 | 7374865 | INSULATOR, field coil (strip type)..... | 2 | ea |
| | | 5330-737-5175 | G740-7375175 | WO-649817 | 7375175 | INSULATOR, ru, 3 ³ / ₁₆ ID, 1 ¹ / ₁₆ OD, 1 ¹ / ₂ lg (mounting support) | 2 | ea |
| 06-2 | H1 | 012-4545 | H001-0518012 | | 124545 | KEY, WOODRUFF, S, (No. 5) 1 ¹ / ₈ x 5 ¹ / ₈ (drive end)..... | 1 | ea |
| | | | | DR-1916325 | 8344313 | LEAD, connecting, brush, assy..... | 1 | ea |
| | | | | | 7538753 7388377 501224 | Composed of: 1 CABLE 1 CLIP PACKING, "O" ring, 1 ¹ / ₁₆ ID, 3 ¹ / ₂ in. thk, (drive end head seal) | | |
| 06-2 | H2 | | H002-0501224 | | | | 1 | ea |

| | | | | | | | | |
|------|----|---------------|-------------------------|-------------------------|--|--|----|----|
| | | G742-7538765 | DR-1916149 WO-118911 | 7538765 | PACKING, PREFORMED, "O" ring, 5 in. ID, 0.135 thk (commutator end head (1), drive end head (1)) (superseded by PACKING 546886) | 2 | ea | |
| 06-2 | H2 | H002-0546886 | | 546886 | PACKING, PREFORMED, "O" ring, class B material (high flexibility), 5 ID, 5 $\frac{1}{16}$ OD, $\frac{1}{8}$ thk (supersedes PACKING 7538765) | 2 | ea | |
| | | G742-7538750 | DR-1913678 WO-118910 | 7538750 | PACKING, PREFORMED, "O" ring, 1.599 ID, 0.135 thk (commutator end head bearing) (superseded by PACKING 546859) | 1 | ea | |
| 06-2 | H2 | H002-0546859 | | 546859 | PACKING, PREFORMED, "O" ring, class B material (high flexibility), 1 $\frac{5}{8}$ ID, $\frac{1}{8}$ thk (supersedes PACKING 7538750) | 1 | ea | |
| | | | DR-1916152 | | PIN, brush plate | 1 | ea | |
| 06-2 | | | DR-1916153 | | PIN, brush plate | 1 | ea | |
| | | | DR-1921761 | | PLATE, brush | 1 | ea | |
| 06-2 | | 2920-741-3318 | G741-7413318 | DR-1921760 WO-119491 | 7413318 | PLATE, brush, assy | 1 | ea |
| | | | DR-1917894 | | Composed of: | | | |
| | | | DR-1904516 | | 2 BUSHING | | | |
| | | | DR-1916133 | | 2 HOLDER | | | |
| | | | DR-1916134 | | 1 INSULATOR | | | |
| | | | DR-1916152 | | 1 INSULATOR | | | |
| | | | DR-1916153 | | 1 PIN | | | |
| | | | DR-1921761 | | 1 PIN | | | |
| | | | DR-1916154 | | 1 PLATE | | | |
| | | | DR-1916155 | | 1 RIVET | | | |
| | | | DR-1916541 | | 1 RIVET | | | |
| | | | DR-191657 | | 2 SUPPORT | | | |
| | | | DR-1916158 | | 1 WASHER | | | |
| 06-2 | | 5310-741-3319 | G741-7413319 | DR-1921747 WO-119496 | 7413319 | 2 WASHER NUT, sp, S, cd-pltd, No. 10-32NF-2 | 2 | ea |
| 06-2 | H1 | H101-0453464 | | 453464 | SCREW, mach, rd-hd, S, cd- or dichromate-pltd, No. 10-32NF-2A x $\frac{1}{2}$ | 2 | ea | |
| 06-2 | H1 | H101-0453296 | | 453296 | WASHER, lock, med, S, cd- pltd, No. 10 | 2 | ea | |
| | | | DR-1921773 WO-119545 | | PLATE, name | 1 | ea | |
| | | | DR-1914906 WO-119019 | | RIVET | 4 | ea | |
| 06-2 | | 2920-753-8783 | G742-7538783 | DR-1916413 WO-118904 | 7538783 | PLATE, retn, commutator end head bearing, w/SPRING | 1 | ea |
| 06-2 | H1 | H101-0453282 | | 453282 | SCREW, mach, fil-hd, S, cd-pltd, No. 10-24NC-2A x $\frac{3}{8}$ | 6 | ea | |
| 06-2 | H1 | H101-0453474 | | 453474 | WASHER, lock, ext-teeth, reg, S, cd-pltd, No. 10 | 6 | ea | |

| (1) | (2) | (3) | (4) | (5) | (6) | (7) | (8) | (9) |
|--|-------------------|-------------------|--------------------|-------------------------------------|-------------------|--|-------------------------------|---------------|
| ILLUSTRATION NO. | REFERENCE SYMBOLS | FEDERAL STOCK NO. | ORDNANCE STOCK NO. | MFR'S PART NO. | ORDNANCE PART NO. | DESCRIPTION | QUANTITY INCORPORATED IN UNIT | UNIT OF ISSUE |
| GROUP 06—ELECTRICAL SYSTEM—Continued | | | | | | | | |
| 0601.3—GENERATOR (24-VOLT) (DELCO-REMY) | | | | | | | | |
| —Continued | | | | | | | | |
| 06-2 | | 2920-753-8760 | G742-7538760 | DR-1916137 WO-118905 | 7538760 | PLATE, retn, drive end head bearing..... | 1 | ea |
| 06-2 | H1 | | H101-0453281 | | 453281 | SCREW, mach, rd-hd, S, cd-pltd, No. 8-32NC-2A x 5/16 | 4 | ea |
| 06-2 | H1 | | H101-0453473 | | 453473 | WASHER, lock, ext-teeth, med, S, cd- or dichromate-pltd, No. 8 | 4 | ea |
| 06-2 | H6 | 011-8831 | H006-0283192 | | 118831 | PLUG, PIPE, sltd, hdls, br, pl-fin, 1/8-27NPT (field frame) | 1 | ea |
| 06-2 | | | G742-7391017 | DR-1916139 WO-118906 | 7391017 | PLUG, rd-hd, sltd, S, cd-pltd, 1 1/8 OD, 1 3/8-12NF-2 (field coil frame inspection) | 1 | ea |
| 06-2 | | 2805-737-5071 | G740-7375071 | DR-1919234 AL-SP992 WO-118824 | 7375071 | PULLEY, drive..... | 1 | ea |
| 06-2 | H1 | | H101-0453327 | | 453327 | NUT, lock, hex, sltd, S, zn- or dichromate-pltd, 1/2-20NF-2 | 1 | ea |
| | | 5310-368-4943 | G741-7374866 | DR-1918043 WO-118908 | 7374866 | WASHER, FLAT, plain, S, zn-pltd, 33/64 ID, 15/16 OD, 3/32 thk (superseded by WASHER 120396) | 1 | ea |
| 06-2 | H1 | | H001-7043801 | | 120396 | WASHER, FLAT, S, cd- or zn-pltd, 1 1/8 ID, 1 1/8 OD, 0.095 thk (supersedes WASHER 7374866) | 1 | ea |
| 06-2 | | 5930-738-8319 | G260-7388319 | DR-1916007 WO-118909 | 7388319 | RECEPTACLE, wtrprf, box mtg No. 22 shell, female socket insert, one No. 12 and two No. 8 cable contacts, assy (terminal) | 1 | ea |
| 06-2 | H1 | | H101-0453847 | | 453847 | SCREW, mach, fil-hd, S, zn- or dichromate-pltd, No. 8-32NC-2A x 7/16 | 4 | ea |
| 06-2 | H1 | | H101-0453299 | | 453299 | WASHER, lock, med, S, cd- or dichromate-pltd, No. 8 | 4 | ea |
| | | | | DR-1916154 DR-1916155 | | RIVET, brush plate..... | 1 | ea |
| | H1 | | H101-0453281 | | 453281 | RIVET, brush plate..... | 1 | ea |
| | H1 | | H101-0453299 | | 453299 | SCREW, mach, rd-hd, S, cd-pltd, No. 8 (0.164) 32NC x 5/16 (field coil ground cable) | 1 | ea |
| 06-2 | | | G742-7538786 | DR-1916642 WO-119011 | 7538786 | WASHER, lock, med, S, cd- or dichromate-pltd, No. 8 | 1 | ea |
| | | | | | | SEAL, PLAIN, ENCASED, oil and water, drive end head | 1 | ea |
| 06-2 | H1 | | H101-0453281 | | 453281 | SCREW, mach, rd-hd, S, cd-pltd, No. 8-32NC-2A x 5/16 | 4 | ea |
| 06-2 | H1 | | H101-0453473 | | 453473 | WASHER, lock, ext-teeth, S, cd- or dichromate-pltd, No. 8 | 4 | ea |
| 06-2 | | | | DR-1921755 WO-119485 | | SHOE, pole..... | 4 | ea |

| | | | | | | | | |
|---|----|---------------|--------------|---------------------------------------|---------|--|---|----|
| 06-2 | H1 | | H101-0453308 | | 453308 | SCREW, mach, fl-hd, cross-recess, S, cd- or dichromate-pltd, $\frac{5}{16}$ -24NF-2A x $\frac{3}{8}$ | 8 | ea |
| 06-2 | | 2920-753-8785 | G742-7538785 | DR-1916419 WO-118912 | 7538785 | SPACER, bearing (commutator end head) | 1 | ea |
| 06-2 | | | G741-7413315 | DR-1916542 WO-119493 | 7413315 | SPRING, brush | 2 | ea |
| | | | | DR-1916416 DR-1916541 WO-649816 | | SPRING, collector | 1 | ea |
| | H1 | 2920-737-5389 | G740-7375389 | | 7375389 | SUPPORT, brush, plate | 2 | ea |
| | H1 | 022-7477 | H101-0227477 | | 227477 | SUPPORT, mounting | 1 | ea |
| | | 5310-012-0382 | H001-7025741 | | 120382 | BOLT, mach, hex-hd, s-fin, alloy-S, $\frac{3}{8}$ -16NC-2 x $\frac{7}{8}$ | 2 | ea |
| 06-2 | | 5310-753-8767 | G742-7538767 | DR-1916160 WO-118914 | 7538767 | WASHER, lock, med, S, cd- or zn-pltd, $\frac{3}{8}$ in. | 2 | ea |
| | | | | DR-1916157 DR-1916158 | | WASHER, br, 0.191 ID, 0.359 OD, 0.023 thk (brush arm) | 2 | ea |
| | H1 | | H001-7025561 | | 131044 | WASHER, brush plate | 1 | ea |
| 06-2 | | 5310-753-8787 | G742-7538787 | DR-1916643 WO-118915 | 7538787 | WASHER, brush plate | 2 | ea |
| 06-2 | | | G742-7538777 | DR-1915853 WO-118999 | 7538777 | WASHER, lock, med, S, cd- or zn-pltd, No. 6 (0.138) (common head) | 2 | ea |
| 06-2 | | 6115-753-8762 | G742-7538762 | DR-1916141 WO-118998 | 7538762 | WASHER, spacing, bearing (drive end head) | 1 | ea |
| 06-2 | | 6115-753-8763 | G742-7538763 | DR-1916143 WO-118997 | 7538763 | WINDING, GENERATOR FIELD, lower left | 1 | ea |
| 06-2 | | | G742-7538761 | DR-1916140 WO-118996 | 7538761 | WINDING, GENERATOR FIELD, lower right | 1 | ea |
| | | | | | | WINDING, GENERATOR FIELD, upper left | 1 | ea |
| | | | | | | WINDING, GENERATOR FIELD, upper right | 1 | ea |
| 0602-GENERATOR REGULATOR (24-VOLT) | | | | | | | | |
| 06-3 | | | | AL-VBC1029 | | ARMATURE, circuit breaker | 1 | ea |
| 06-3 | | | | AL-VBC1061 | | ARMATURE, current regulator | 1 | ea |
| 06-3 | | | | AL-VBC1080 | | ARMATURE, voltage regulator | 1 | ea |
| 06-3 | H1 | | H101-0131966 | | 131966 | SCREW, fil-hd, Sems type, No. 8-32NC x $\frac{7}{16}$ | 6 | ea |
| 06-3 | H1 | 013-1015 | H001-7043591 | | 131015 | WASHER, FLAT, med, S, cd- or zn-pltd, No. 8 | 6 | ea |
| 06-3 | | 2920-737-4917 | G741-7374917 | AL-VBC1055 WO-118793 | 7374917 | BASE, insulating | 1 | ea |
| 06-3 | H1 | 013-2908 | H001-5148851 | | 132908 | SCREW, mach, rd-hd, S, cd- or zn-pltd, No. 10-32NF-2A x $\frac{1}{2}$ | 6 | ea |
| 06-3 | H1 | 5310-012-0391 | H001-7043621 | | 120391 | WASHER, FLAT, med, S, cd- or zn-pltd, $\frac{3}{16}$ in. | 4 | ea |
| | | 2920-737-4918 | G741-7374918 | AL-VBC1040S WO-118787 | 7374918 | BASE, w/name PLATE, assy (includes RECEPTACLE, RECTIFIER, RESISTOR, TERMINAL, and FILTER) | 1 | ea |
| 06-3 | H1 | 042-4632 | H101-0424632 | | 424632 | BOLT, INTEGRAL LOCK WASHER, S, ext-teeth, rd-hd, sld, cd- or zn-pltd, $\frac{1}{4}$ -28NF-2 x $\frac{5}{16}$ (filter terminal) | 2 | ea |

| (1) | (2) | (3) | (4) | (5) | (6) | (7) | (8) | (9) |
|------------------|-------------------|-------------------|--------------------|------------------------------------|-------------------|--|-------------------------------|---------------|
| ILLUSTRATION NO. | REFERENCE SYMBOLS | FEDERAL STOCK NO. | ORDNANCE STOCK NO. | MFR'S PART NO. | ORDNANCE PART NO. | DESCRIPTION | QUANTITY INCORPORATED IN UNIT | UNIT OF ISSUE |
| | | | | | | GROUP 06—ELECTRICAL SYSTEM—Continued | | |
| | | | | | | 0602—GENERATOR REGULATOR (24-VOLT) | | |
| | | | | | | —Continued | | |
| 06-3 | | | | AL-VRA1060A AL-X3050 | | BRACKET, adj, air gap, current and voltage regulators | 2 | ea |
| 06-3 | H1 | 013-1015 | H001-7043591 | | 131015 | SCREW, fil-hd, Sems type, No. 8-32NC x $\frac{5}{16}$ | 4 | ea |
| 06-3 | | 2920-737-4822 | G741-7374822 | AL-VBC19 WO-118753 | 7374822 | WASHER, FLAT, med, S, cd- or zn-pltd, No. 8 | 4 | ea |
| 06-3 | | 2920-737-4823 | G741-7374823 | AL-VBC43 WO-118757 | 7374823 | BRACKET, current regulator core resistor | 1 | ea |
| 06-3 | H1 | 018-7979 | H101-0187979 | | 187979 | BRACKET, mounting (regulator) | 2 | ea |
| 06-3 | | 2920-737-4921 | G741-7374921 | AL-VBC21 WO-118754 | 7374921 | BOLT, INTEGRAL LOCK WASHER, hex-hd, S, cd- or zn-pltd, $\frac{1}{4}$ -20NC-2 x $\frac{1}{4}$ | 4 | ea |
| 06-3 | | 5925-737-4945 | G741-7374945 | AL-VBC3070 WO-118795 | 7374945 | BRACKET, voltage regulator core resistor | 1 | ea |
| 06-3 | H1 | 050-3342 | H001-0725250 | | 503342 | BREAKER, circuit, assy | 1 | ea |
| 06-3 | | 5310-737-5357 | G740-7375357 | AL-VAD176 WO-117017 | 7375357 | NUT, SELF-LOCKING, HEXAGON, safety, br, $\frac{1}{4}$ -28NF-3 (critical installations) | 1 | ea |
| 06-3 | H1 | | H101-0446187 | | 446187 | WASHER, FLAT, S, cd- or zn-pltd, $\frac{1}{4}$ in. (superseded by WASHER 446187) | 1 | ea |
| 06-3 | | | | AL-GAA35A AL-VBC23 WO-118762 | 8393092 | WASHER, FLAT, S, $\frac{1}{4}$ ID, $\frac{5}{8}$ OD, 0.049 thk (supersedes WASHER 7375357) | 1 | ea |
| 06-3 | | 5910-737-4919 | G741-7374919 | AL-XA770 WO-118775 | 7374919 | BUSHING, insulating, circuit breaker contact bracket | 2 | ea |
| 06-3 | | 2920-737-4920 | G741-7374920 | AL-VBC40 WO-118764 | 8673471 | BUSHING, insulating (resistor attaching) | 1 | ea |
| 06-3 | H1 | | H001-0725140 | AL-VBC1016 WO-118786 | 7374920 | CAPACITOR, assy | 1 | ea |
| 06-3 | | 5310-734-7560 | G741-7347560 | AL-XA766 WO-118774 | 7347560 | CASE | 1 | ea |
| 06-3 | | 2920-362-3284 | G741-7348949 | AL-VBA46 WO-A9052 AL-VAD1118 | 7348949 | CHOCHE, radio suppression (rf) | 1 | ea |
| | | | | | 503240 | NUT, safety, br, No. 8 (0.164)-32NC-2 (supersedes NUT 7347560) | 1 | ea |
| | | | | | | NUT, SELF-LOCKING, HEXAGON, elastic stop, No. 8-32NC (superseded by NUT 503240) | 1 | ea |
| | | | | | | CONNECTOR, bar, series coil | 1 | ea |
| | | | | | | CONTACT, stationary, circuit breaker | 1 | ea |

| | | | | | | | | |
|------|----|---------------|--------------|--------------------------|---------|---|---|----|
| 06-3 | | 2920-737-4825 | G741-7374825 | AL-VBC2 WO-118752 | 7374825 | COVER..... | 1 | ea |
| 06-3 | H1 | 012-7651 | H101-0127651 | | 127651 | BOLT, MACHINE, hex-hd, slotted, S, cd- or zn-pltd, No. 10-32NF-2 x 3/4 | 6 | ea |
| 06-3 | | 2920-737-4922 | G741-7374922 | AL-VBC31 WO-118756 | 7374922 | CUSHION, mtg bracket, w/STUD, assy..... | 4 | ea |
| 06-3 | | 2920-737-4923 | G741-7374923 | AL-XA783 WO-118771 | 7374923 | FILTER, radio suppression, assy..... | 1 | ea |
| 06-3 | H1 | 017-8469 | H101-0178469 | | 178469 | BOLT, INTEGRAL LOCK WASHER, rd-hd, sltd, ext-teeth, No. 10 (0.190)-32NF-2 x 3/8 | 1 | ea |
| | | | G244-7716562 | AL-XA767 WO-118769 | 7716562 | GASKET, receptacle mtg (superseded by GASKET AL-XA767A) | 2 | ea |
| 06-3 | | | | AL-XA767A WO-119998 | | GASKET, receptacle mtg (supersedes GASKET 7716562) | 2 | ea |
| | | | | AL-VAD116A | | INSULATOR, inner circuit breaker contact..... | 1 | ea |
| | | | | AL-VAD117A | | INSULATOR, outer circuit breaker contact..... | 1 | ea |
| 06-3 | | | | AL-VBC25 | 8393093 | LEAD, assy (base)..... | 1 | ea |
| | | | | WO-118763 | | | | |
| 06-3 | | | | AL-VBC46 | 8393090 | LEAD, assy (cutout relay to fillerette terminal)..... | 1 | ea |
| | | | | WO-118758 | | | | |
| 06-3 | | | | AL-VBC47 | 8393095 | LEAD, 2 1/4 lg (base)..... | 1 | ea |
| | | | | WO-118766 | | | | |
| | | | | AL-XA699 | | NUT, hex, elastic stop, No. 10-32NF (lead connection (3), resistor mtg (1)) (superseded by NUT AL-XA699A) | 4 | ea |
| | | | | WO-118768 | | | | |
| 06-3 | | | | AL-XA699A | | NUT, hex, elastic stop, No. 10-32NF (lead connection (3), resistor mtg (1)) (supersedes NUT AL-XA699) | 4 | ea |
| | | | | WO-119478 | | | | |
| | | 5330-737-4964 | G741-7374964 | AL-XA744N | 7374964 | PACKING, PREFORMED, "O" ring, 6 3/4 OD (cover) (superseded by PACKING 546896) | 1 | ea |
| | | | | WO-118772 | | | | |
| 06-3 | H2 | | H002-0546896 | | 546896 | PACKING, PREFORMED, "O" ring, class B material (high flexibility), 6 1/2 OD, 1/8 thk (supersedes PACKING 7374964) | 1 | ea |
| 06-3 | | | | AL-VBC42 | 8393094 | PLATE, SHIELD (filter terminal)..... | 1 | ea |
| | | | | WO-118765 | | | | |
| 06-3 | H1 | 017-8469 | H101-0178469 | | 178469 | BOLT, INTEGRAL LOCK WASHER, rd-hd, sltd, ext-teeth, S, cd- or zn-pltd, No. 10 (0.190)-32NF-2 x 3/8 | 2 | ea |
| 06-3 | H6 | 044-4614 | H106-0444614 | | 444614 | PLUG, PIPE, hex, br, cd- or zn-pltd, 1/8-27NPT (regulator drain) | 1 | ea |
| 06-3 | | 2920-737-4924 | G741-7374924 | AL-VBC1036A WO-118788 | 7374924 | RECEPTACLE, base, assy..... | 1 | ea |
| 06-3 | | 2920-737-4925 | G741-7374925 | AL-VBC1044 WO-118789 | 7374925 | RECEPTACLE, w/CABLE, assy..... | 1 | ea |
| 06-3 | | | | AL-X3051 WO-118791 | | SCREW, fil-hd, Sems type, No. 8-32NC x 1/16..... | 8 | ea |

| (1) ILLUSTRATION NO. | (2) REFERENCE SYMBOLS | (3) FEDERAL STOCK NO. | (4) ORDNANCE STOCK NO. | (5) MFR'S PART NO. | (6) ORDNANCE PART NO. | (7) DESCRIPTION | (8) QUANTITY INCORPORATED IN UNIT | (9) UNIT OF ISSUE |
|-------------------------|--------------------------|--------------------------|---------------------------|-------------------------|--------------------------|--|--------------------------------------|----------------------|
| | | | | | | GROUP 06—ELECTRICAL SYSTEM—Continued | | |
| | | | | | | 0602—GENERATOR REGULATOR (24-VOLT) | | |
| | | | | | | —Continued | | |
| 06-3 | | 2920-737-4960 | G741-7374960 | AL-XA782 WO-118770 | 7374960 | RECTIFIER, radio suppression..... | 1 | ea |
| 06-3 | H1 | 017-8469 | H101-0178469 | | 178469 | BOLT, INTEGRAL LOCK WASHER, rd-hd, sltd, ext-teeth, S, cd- or zn-pltd, No. 10 (0.190)-32NF-2 x 3/8 | 2 | ea |
| 06-3 | | 2920-737-4943 | G741-7374943 | AL-VBC3008 WO-118794 | 7374943 | REGULATOR, current, assy..... | 1 | ea |
| 06-3 | H1 | 050-3342 | H001-0725250 | | 503342 | NUT, SELF-LOCKING, HEXAGON, safety, br, 1/4-28NF-3 (critical installations) | 1 | ea |
| 06-3 | | 2920-752-4309 | G741-7524309 | AL-VBC4002 WO-800127 | 7524309 | REGULATOR, generator, assy..... | 1 | ea |
| 06-3 | H1 | 042-6894 | H101-0426894 | | 426894 | NUT, PLAIN, HEXAGON, jam, s-fin, S, 5/16-18NC-2.... | 4 | ea |
| 06-3 | H1 | | H101-0221177 | | 221177 | WASHER, LOCK, reg, S, tinned, 5/16 in..... | 4 | ea |
| 06-3 | | 2920-737-4944 | G741-7374944 | AL-VBC3071 WO-118796 | 7374944 | REGULATOR, voltage, assy..... | 1 | ea |
| 06-3 | H1 | 050-3342 | H001-0725250 | | 503342 | NUT, SELF-LOCKING, HEXAGON, safety, br, 1/4-28NF-3 (critical installations) | 1 | ea |
| 06-3 | | 5905-737-4961 | G741-7374961 | AL-VRP100C WO-118776 | 7374961 | RESISTOR, carbon (15 ohm)..... | 1 | ea |
| 06-3 | | | G758-8332078 | AL-VRP100K WO-119479 | 8332078 | RESISTOR, carbon (400 ohm)..... | 1 | ea |
| 06-3 | H1 | 5305-012-0628 | H001-5151031 | | 120628 | SCREW, MACHINE, rd-hd, S, cd- or zn-pltd, 1/4-20NC-2 x 1/2 | 4 | ea |
| 06-3 | H1 | 013-1015 | H001-7043591 | | 131015 | WASHER, fl, med, S, cd- or zn-pltd, No. 8..... | 4 | ea |
| 06-3 | | | | AL-VBC22 WO-118761 | 8393091 | RESISTOR, carbon, button type..... | 1 | ea |
| 06-3 | | | | AL-EWD62 WO-118759 | 8672285 | WASHER, INSULATING..... | 1 | ea |
| 06-3 | | | | AL-XA699A WO-119478 | | NUT, hex, elastic stop, No. 10-32NF..... | 1 | ea |
| 06-3 | H1 | 013-2923 | H001-5148891 | | 132923 | SCREW, mach, rd-hd, S, cd- or zn-pltd, No. 10-32NF-2A x 1 | 1 | ea |
| 06-3 | H1 | 5310-011-6090 | H001-1522005 | | 116090 | WASHER, FLAT, med, br, 1/2 ID, 1/2 OD, 0.049 thk.... | 1 | ea |
| 06-3 | | 5305-737-5371 | G740-7375371 | WO-118724 AL-8X3029 | 7375371 | SCREW, int-teeth lock washer, fil-hd, No. 10-32NF x 1 1/16 (lead connection) | 2 | ea |
| 06-3 | | | | AL-X3055 WO-118800 | | SCREW, int-teeth lock washer, fil-hd, No. 10-32NF x 1 1/16 (lead connection) | 2 | ea |

| | | | | | | | |
|---------------------|---------------|--------------|--|---------|---|---|----|
| 06-3 | 5305-362-3305 | G502-7702665 | AL-VRA16 | 7702665 | SCREW, mach, br, No. 10-48NS-2 x 1 $\frac{9}{32}$ | 3 | ea |
| 06-3 | 5310-770-2608 | G507-7702608 | AL-VRA15 | 7702608 | NUT, knurled, br, No. 10 (0.190)-48NS | 3 | ea |
| 06-3 | 5340-362-3308 | G507-7702645 | AL-VRA84 | 7702645 | SPRING, extn, corr-res-S, 0.048 dia stk, 0.302 OD, 1 $\frac{5}{16}$ lg (voltage regulator armature) (M5) | 1 | ea |
| 06-3 | 5340-362-3307 | G507-7702646 | AL-VRA17 | 7702646 | SPRING, extn, corr-res-S, 0.048 dia stk, 14 $\frac{1}{2}$ coils, 0.320 ID, 1 $\frac{1}{16}$ lg (M5) (current regulator and circuit breaker armature) (M5) | 2 | ea |
| 06-3 | 6150-737-4965 | G741-7374965 | AL-VBC30 WO-118755 | 7374965 | STRAP, ground | 4 | ea |
| 06-3 | | | AL-VBC18 WO-118760 | 8672286 | TERMINAL, resistor | 1 | ea |
| 0603-STARTER | | | | | | | |
| 06-4 | | G741-8328057 | AL-MCZ2006F WO-119636 | 8328057 | ARMATURE, assy | 1 | ea |
| 06-5 | | | AL-MCZ69 AL-MCZ1069 WO-119638 | | BASE, switch | 1 | ea |
| 06-4 | 3120-362-1368 | G741-5346762 | AL-MP41A WO-119631 | 5346762 | BASE, switch, assy | 1 | ea |
| 06-5 | | G741-8328065 | AL-MCZ1065 WO-119639 | 8328065 | BEARING, bushing type, bz (pinion housing) | 1 | ea |
| 06-4 | | | AL-MCS1034S WO-119635 | | BLADE, switch, w/PLUNGER, assy | 1 | ea |
| 06-4 | | | AL-MCS12 WO-119610 | | BRUSH, grounded (plate) | 2 | ea |
| 06-4 | 5975-736-9889 | G741-7369889 | AL-MCS2012S WO-119768 | 7369889 | BRUSH, insulated (frame and field) | 1 | ea |
| | | | AL-MCS1034S AL-MCS12 AL-MCS69 WO-119621 | | BRUSH SET, starter | 1 | ea |
| 06-5 | | | AL-MCS67 WO-119620 | | Composed of: 2 BRUSH 2 BRUSH | | |
| 06-5 | | | G740-8328139 | 8328139 | BUSHING, insulating (terminal stud) | 2 | ea |
| 06-4 | | | AL-MCL3161A WO-118645 | | BUSHING, terminal stud | 2 | ea |
| 06-4 | | G740-8328140 | AL-MCZ64 WO-119612 | 8328140 | CLUTCH, starter, assy | 1 | ea |
| 06-4 | | G741-8328056 | AL-MCS2079S WO-119632 | 8328056 | CONNECTOR, switch to field coil | 1 | ea |
| 06-4 | 5330-521-4539 | G508-5214539 | LO-FC602 WO-637604 | 5214539 | FRAME, w/field COILS, assy | 1 | ea |
| | | | G740-8328141 | 8328141 | GASKET, cop, 0.510 ID, 1 $\frac{3}{16}$ OD, $\frac{1}{32}$ thk (starter to bell housing) | 2 | ea |
| 06-5 | | G741-8328062 | AL-MCZ66 WO-119614 | 8328062 | GASKET, starter | 1 | ea |
| | | | | | GASKET, switch cover | 2 | ea |

| (1) ILLUSTRATION NO. | (2) REFER- ENCE SYMBOLS | (3) FEDERAL STOCK NO. | (4) ORDNANCE STOCK NO. | (5) MFR'S PART NO. | (6) ORDNANCE PART NO. | (7) DESCRIPTION | (8) QUANTITY INCOR- PORATED IN UNIT | (9) UNIT OF ISSUE |
|---|----------------------------------|-----------------------------|------------------------------|-------------------------|-----------------------------|--|---|----------------------------|
| GROUP 06—ELECTRICAL SYSTEM—Continued | | | | | | | | |
| 0603—STARTER—Continued | | | | | | | | |
| 06-5 | | 5330-737-4930 | G741-7374930 | AL-MCS78 WO-119622 | 7374930 | GASKET, terminal stud..... | 2 | ea |
| 06-4 | | | G740-8328135 | AL-MCS1083 WO-119633 | 8328135 | HEAD, commutator end, w/BEARING, assy..... | 1 | ea |
| 06-4 | H1 | 013-1970 | H001-5125851 | | 131970 | SCREW, mach, fil-hd, S, cd- or zn-pltd, No. 8-32NC-2A x 1/2 | 6 | ea |
| 06-4 | H1 | 5310-042-6678 | H101-0426678 | | 426678 | WASHER, lock, med, S, tin-pltd, No. 8..... | 6 | ea |
| 06-4 | | | G740-8328136 | AL-PS1310 WO-119649 | 8328136 | HOUSING, drive pinion..... | 1 | ea |
| 06-4 | H1 | | H101-0271122 | | 271122 | SCREW, hex-hd, S, cd-pltd, No. 8-32NF-2 x 1 1/16..... | 6 | ea |
| 06-4 | H1 | 5310-042-6678 | H101-0426678 | | 426678 | WASHER, LOCK, med, S, tin-pltd, No. 8..... | 6 | ea |
| 06-5 | | | | AL-MCZ73 WO-119623 | | HOUSING, switch terminal..... | 1 | ea |
| 06-5 | H1 | | H001-5127351 | | 120216 | SCREW, fil-hd, S, cd-pltd, No. 10-32NF-2 x 1/2..... | 4 | ea |
| 06-5 | H1 | 5310-043-1680 | H101-0431680 | | 431680 | WASHER, lock, reg, S, tin-pltd, No. 10..... | 4 | ea |
| 06-5 | | | G741-8328061 | AL-MCZ62 WO-119613 | 8328061 | INSULATOR, switch..... | 2 | ea |
| | | | G740-8328144 | AL-MCZ1072 WO-119646 | 8328144 | LEVER, shifting yoke shaft (superseded by LEVER AL-MCZ1075) | 1 | ea |
| 06-4 | | | | AL-MCZ1075 WO-120252 | | LEVER, shifting yoke shaft (supersedes LEVER 8328144). | 1 | ea |
| 06-4 | H1 | 012-4543 | H001-0518010 | | 124543 | KEY, WOODRUFF, ni-S, 1/8 x 1/2 (No. 404 or 3)..... | 2 | ea |
| 06-4 | H1 | 013-7185 | H001-4417731 | | 137185 | PIN, cotter, split, S, 1/8 x 1..... | 1 | ea |
| 06-4 | | 5310-734-7571 | G741-7347571 | AL-X1379 WO-119643 | 7347571 | NUT, hex, cop or br, 3/8-16NC-2 (terminal stud)..... | 1 | ea |
| 06-4 | H2 | 054-6875 | H002-0546875 | | 546875 | PACKING, preformed, "O" ring, synthetic ru, 3 5/8 ID, 3 7/8 OD (commutator end head (1), pinion housing (1)) | 2 | ea |
| 06-4 | H2 | 050-1220 | H002-0501220 | | 501220 | PACKING, preformed, synthetic ru, 3/8 ID, 1/2 OD (shifting yoke shaft) | 1 | ea |
| 18-6 | | 2920-776-0417 | G740-7760417 | WO-801797 | 7760417 | PEDAL, starter switch..... | 1 | ea |
| | H1 | | H101-0271172 | | 271172 | NUT, hex, w/ext-teeth lock washer, Keps type, 1/4-20NC-2 | 3 | ea |
| | H1 | 012-0854 | H001-5417601 | | 120854 | SCREW, mach, hex-hd, S, cd- or zn-pltd, 1/4-20NC-3 x 3/8 | 3 | ea |
| | H1 | 5310-012-0386 | H001-7045531 | | 120386 | WASHER, FLAT, S, cd- or zn-pltd, 5/16 ID, 3/4 OD, 0.065 thk | 3 | ea |

| | | | | | | | | |
|------------------|----|---------------|--------------|---------------------------|---------|--|---|----|
| 06-4 | | 2920-737-4938 | G741-7374938 | AL-MCS-1278 WO-119634 | 7374938 | PLATE, w/BRUSH and SPRING, assy..... | 1 | ea |
| 06-4 | H1 | 5305-013-3482 | H001-5087931 | | 183482 | SCREW, mach, fl-hd, S, cd- or zn-pltd, No. 8-32NC-2A x 3/8 | 4 | ea |
| 06-5 | H6 | 011-8831 | H006-0283192 | | 118831 | PLUG, pipe, sltd, hdls, br, pl-fin, 1/8-27NPT (field frame) | 1 | ea |
| 06-5 | | | | AL-MCS57 WO-119618 | | RETAINER, S, cd-pltd, 0.502 ID, 0.792 OD, 0.080 thk (terminal stud gasket) | 2 | ea |
| 06-4 | | | G741-8328071 | AL-MCZ49 WO-119627 | 8328071 | RETAINER, shifting yoke shaft..... | 1 | ea |
| 06-4 | | | | AL-19X888 WO-119829 | | SCREW, mach, fil-hd, S, cd-pltd, No. 8-32NC x 1/8..... | 1 | ea |
| 06-4 | H1 | 5310-042-6678 | H101-0426678 | | 426678 | WASHER, lock, med, S, tin-pltd, No. 8..... | 1 | ea |
| 06-4 | | 2920-353-7400 | G741-7374940 | AL-MCS46A WO-119629 | 7374940 | RETAINER, snap ring (also known as pinion STOP)..... | 1 | ea |
| 06-5 | | | G741-8328063 | AL-MCZ70 WO-119615 | 8328063 | RETAINER, spring, switch base..... | 1 | ea |
| 06-4 | | 5340-734-7572 | G741-7347572 | AL-MCS47A WO-119630 | 7347572 | RING, retn, snap, S, cd-pltd, (retainer and pinion stop)... | 1 | ea |
| 06-4 | | | | AL-19X3168 WO-119766 | | SCREW, cap, hex-hd, S, cd-pltd, 5/16-24NF-2 x 1 1/16 (plunger adj) | 1 | ea |
| 06-4 | H1 | 012-4920 | H001-4185561 | | 124920 | NUT, plain, hex, lt, s-fin, S, cd- or zn-pltd, 5/16-24NF-2. | 1 | ea |
| 06-5 | | | G741-8328066 | AL-XA744S WO-119617 | 8328066 | SEAL, "O" ring, 3/8 OD (switch plunger)..... | 1 | ea |
| 06-4 | | | G741-8328067 | AL-MCZ77 WO-119628 | 8328067 | SHAFT, shifting yoke..... | 1 | ea |
| 06-4 | | 5340-358-7657 | G740-7375301 | AL-MZ19A WO-117861 | 7375301 | SPRING, brush holder..... | 4 | ea |
| 06-5 | | | G741-8328064 | AL-MCZ71 WO-119616 | 8328064 | SPRING, switch blade..... | 1 | ea |
| | | | G758-8329740 | DR-X10483 WO-804758 | 8329740 | STARTER, assy (24 v, wtrprf) (optional w/STARTER 8328132) | 1 | ea |
| 01-2, 4, 06-4 | | | G740-8328132 | AL-MCZ4001UT WO-804376 | 8328132 | STARTER; assy (24 v, wtrprf) (optional w/STARTER 8329740) | 1 | ea |
| | | | G508-5214539 | WO-637604 | A214539 | GASKET, cop, 0.510 ID, 1 3/16 OD, 1/32 thk ((1) under SCREW 120426, (1) under NUT 503323) | 2 | ea |
| | H1 | 050-3323 | H001-4040581 | | 503323 | NUT, self-locking, hex, S, cd- or zn-pltd, 1/2-20NF-3... | 1 | ea |
| | H1 | | H001-5458841 | | 124378 | SCREW, cap, hex-hd, S, cd- or zn-pltd, 1/2-20NF-3 x 3 1/2 | 1 | ea |
| | H1 | 012-0426 | H001-5423761 | | 120426 | SCREW, mach, hex-hd, S, cd- or zn-pltd, 1/2-13NC-3 x 1 1/4 | 1 | ea |
| | H1 | | H101-0451975 | | 451975 | SCREW, mach, hex-hd, w/spring lock washer, S, cd- or zn-pltd, 5/16-18NC x 3/4 | 1 | ea |
| | H1 | 5310-012-0384 | H001-7025801 | | 120384 | WASHER, lock, med, S, cd- or zn-pltd, 1/2 in..... | 1 | ea |

| (1) ILLUSTRATION NO. | (2) REFERENCE SYMBOLS | (3) FEDERAL STOCK NO. | (4) ORDNANCE STOCK NO. | (5) MFR'S PART NO. | (6) ORDNANCE PART NO. | (7) DESCRIPTION | (8) QUANTITY INCORPORATED IN UNIT | (9) UNIT OF ISSUE |
|---|--------------------------|--------------------------------|------------------------------|-------------------------|--------------------------|---|--------------------------------------|----------------------|
| GROUP 06—ELECTRICAL SYSTEM—Continued | | | | | | | | |
| 0603—STARTER—Continued | | | | | | | | |
| 06-5 | | | | AL-MCZ1060 WO-119642 | | STUD, switch terminal..... | 1 | ea |
| 06-5 | | | | AL-MCS63 WO-119619 | | INSULATOR..... | 1 | ea |
| 06-4, 5 | | 5310-734-7571 | G741-7347571 | AL-X1379 WO-119643 | 7347571 | NUT, hex, cop or br, $\frac{3}{8}$ -16NC-2..... | 1 | ea |
| 06-4, 5 | H1 | 5310-043-2646 5310-734-7568 | H101-0432646 G741-7347568 | AL-MN47B WO-119624 | 432646 7347568 | WASHER, lock, S, tin-fin, $\frac{3}{8}$ in..... WASHER, FLAT, S, cd-pltd, 0.380 ID, 0.625 OD, 0.042 thk (superseded by WASHER 446548) | 1 1 | ea ea |
| 06-5 | H1 | | H101-0446548 | | 446548 | WASHER, FLAT, S, cd- or zn-pltd, $\frac{3}{8}$ ID, $\frac{1}{4}$ OD, 0.065 thk (supersedes WASHER 7347568) | 1 | ea |
| 06-5 | | | | AL-MCS1060 WO-119641 | | STUD, switch terminal..... | 1 | ea |
| 06-5 | | 5310-734-7571 | G741-7347571 | AL-X1379 WO-119643 | 7347571 | NUT, hex, cop or br, $\frac{3}{8}$ -16NC-2..... | 1 | ea |
| 06-5 | H1 | 013-4570 | H001-4133820 | | 134570 | NUT, plain, hex, br, $\frac{3}{8}$ -16NC-2..... | 1 | ea |
| 06-5 | | | | AL-MC863 WO-119619 | | INSULATOR..... | 1 | ea |
| 06-4, 5 | H1 | 5310-043-2646 5310-734-7568 | H101-0432646 G741-7347568 | AL-MN47B WO-119624 | 432646 7347568 | WASHER, lock, S, tin-fin, $\frac{3}{8}$ in..... WASHER, flat, S, cd-pltd, 0.380 ID, 0.625 OD, 0.042 thk (superseded by WASHER 446548) | 2 1 | ea ea |
| 06-5 | H1 | | H101-0446548 | | 446548 | WASHER, flat, S, cd- or zn-pltd, $\frac{3}{8}$ ID, $\frac{1}{4}$ OD, 0.065 thk (supersedes WASHER 7347568) | 1 | ea |
| | H1 | | G740-8328133 H101-0451976 | WO-804362 | 8328133 451976 | SUPPORT, mounting..... SCREW, mach, hex-hd, w/spring lock washer, S, cd- or zn-pltd, $\frac{3}{8}$ -16UNC-2A x $\frac{1}{4}$ | 1 1 | ea ea |
| 06-4, 5 | | | G740-8328134 | AL-MCZ2073 WO-119637 | 8328134 | SWITCH, assy..... | 1 | ea |
| 06-4 | | | | AL-19X709 WO-117904 | | SCREW, mach, fil-hd, S, cd-pltd, No. 10-32NF x $\frac{1}{16}$ | 4 | ea |
| 06-4 | H1 | 5310-043-1680 | H101-0431680 | | 431680 | WASHER, lock, reg, S, tin, No. 10 (switch mounting screw) | 4 | ea |
| | | | | AL-MCZ1073 WO-119640 | | TERMINAL, switch, assy..... | 1 | ea |
| 06-4 | H1 | 5310-043-2646 3120-530-8275 | H101-0432646 G507-5308275 | AL-MU54 WO-109455 | 432646 5308275 | WASHER, lock, S, tin-fin, $\frac{3}{8}$ in. (terminal)..... WASHER, thrust, armature (commutator end) (0.0312 thk) | 1 1 | ea ea |

| | | | | | | | | |
|-----------------------------|----|---------------|--------------|---------------------------|---------|--|---|----|
| | | 3120-534-6760 | G502-5346760 | AL-MU54B WO-117337 | 5346760 | WASHER, thrust, armature (commutator end) (0.045 thk) | † | ea |
| 06-4 | | | G741-8328058 | AL-MU54L WO-119596 | 8328058 | WASHER, thrust, armature (commutator end) (0.0625 thk) | 1 | ea |
| 06-4 | | 3120-736-9888 | G741-7369888 | AL-MN18A WO-119611 | 7369888 | WASHER, thrust, armature (drive end) | 1 | ea |
| 06-4 | | | G507-5308307 | AL-MAD110 WO-117858 | 5308307 | WICK, felt, commutator end head bearing | 1 | ea |
| 06-4 | | | G741-8328069 | AL-MCZ2050 WO-119647 | 8328069 | YOKE, assy (clutch) | 1 | ea |
| 0604.1 - DISTRIBUTOR | | | | | | | | |
| 06-6 | | 2920-737-5372 | G740-7375372 | AL-IAU20 WO-118729 | 7375372 | ARM, spark advance control | 1 | ea |
| 06-6 | H1 | 021-4002 | H001-5025521 | | 214002 | BOLT, MACHINE, hex-hd, S, cd- or zn-pltd, ¼-20NC-2 x ¾ | 1 | ea |
| 06-6 | H1 | 5310-012-0387 | H001-7045561 | | 120387 | WASHER, FLAT, plain, S, zn-pltd, ⅜ ID, ⅝ OD, ⅛ thk | 1 | ea |
| 06-6 | H1 | 5310-043-1543 | H101-0431543 | | 431543 | WASHER, LOCK, hv, S, tin-pltd, ¼ in. | 1 | ea |
| 06-6 | | | G758-8329785 | AL-IAU2064S2 WO-120202 | 8329785 | BASE, w/BEARING, assy | 1 | ea |
| | | | | | 542109 | Composed of: | | |
| | | | | | 7347547 | 2 BUSHING | | |
| | | | | | 7351671 | 1 PLUG | | |
| | | | | | | 1 SEAL | | |
| | | | | | | 1 WASHER | | |
| | | | | | | 1 WASHER | | |
| 06-6 | H1 | 2920-353-7248 | G502-7329386 | AL-IGC1149 | 7329386 | BRACKET, stationary, contact | 1 | ea |
| | | | H001-2010620 | | 542109 | BUSHING, bz, ½ ID, ⅝ OD, 1 lg (base) | 2 | ea |
| 06-6 | | | | AL-RX2781 | | CABLE, breaker lever to coil, 4¾ lg | 1 | ea |
| 06-6 | | 2920-737-5378 | G740-7375378 | AL-IAU1100L WO-118718 | 7375378 | CAM, breaker, w/stop PLATE (welded) | 1 | ea |
| 06-6 | | 2920-353-7206 | G740-7375377 | AL-IAU1048 WO-118717 | 7375377 | CAP, distributor | 1 | ea |
| 06-6 | H1 | | H101-0455219 | | 455219 | SCREW, mach, w/int-teeth-lock washer, fil-hd, S, cd- or zn-pltd, Sens type, No. 8-32NC-2 x 1 | 3 | ea |
| | | | | AL-IAU2076L | | CAPACITOR, breaker plate | 1 | ea |
| | | | | AL-XA790 | | CAPACITOR, receptacle | | |
| 06-6 | | | G758-8329784 | AL-IAU1065 WO-119058 | 8329784 | CAPACITOR, w/TERMINAL, assy (receptacle) | 1 | ea |
| | | | | AL-XA790 | | Composed of: | | |
| | | | | AL-IGB26 | | 1 CAPACITOR | | |
| | | | | | | 1 TERMINAL | | |

| (1) ILLUSTRATION NO. | (2) REFERENCE SYMBOLS | (3) FEDERAL STOCK NO. | (4) ORDNANCE STOCK NO. | (5) MFR'S PART NO. | (6) ORDNANCE PART NO. | (7) DESCRIPTION | (8) QUANTITY INCORPORATED IN UNIT | (9) UNIT OF ISSUE |
|---|--------------------------|--------------------------|---------------------------|----------------------------|--------------------------|---|--------------------------------------|----------------------|
| GROUP 06—ELECTRICAL SYSTEM—Continued | | | | | | | | |
| 0604.1—DISTRIBUTOR—Continued | | | | | | | | |
| 06-6 | | 5910-358-6842 | G741-7374881 | AL-IAU3076L WO-118720 | 7374881 | CAPACITOR, w/TERMINAL, assy (contact points)..... | 1 | ea |
| 06-6 | H1 | | H101-0455209 | AL-IAU2076L AL-IGB132 | 455209 | Composed of: 1 CAPACITOR 1 TERMINAL | | |
| 06-6 | | 2920-362-2995 | G507-5346775 | AL-IG676 WO-A1663 | 5346775 | SCREW, mach, w/int-teeth lock washer, fil-hd, S, cd- or zn-pltd, No. 6-32NC-2A x 3/16 | 1 | ea |
| 06-6 | | | G741-7351133 | AL-IGS19S WO-117091 | 7351133 | CLIP, breaker lever spring..... | 1 | ea |
| 06-6 | H1 | | H101-0583842 | | 583842 | SCREW, MACH, hex-hd, S, cd- or zn-pltd, No. 6-32NC-2 x 5/16 | 1 | ea |
| 06-6 | H1 | 013-1014 | H001-7043561 | | 131014 | WASHER, FLAT, med, S, cd- or zn-pltd, 1/32 ID, 3/8 OD, 0.049 thk | 1 | ea |
| 06-6 | H1 | | H101-0500494 | | 500494 | WASHER, lock, lt, S, tin-pltd, No. 6..... | 1 | ea |
| 06-6 | | | G758-8329605 | AL-IAU6 WO-119053 | 8329605 | CLIP, lead cable, hole for No. 8 screw..... | 2 | ea |
| 06-6 | | 2920-737-4882 | G741-7374882 | AL-CT4002 WO-118712 | 7374882 | COIL, ignition (see subgroup 0605)..... | 1 | ea |
| 06-6 | | 2920-366-6480 | G741-7351133 | AL-IGS19S WO-117091 | 7351133 | COLLAR, drive shaft..... | 1 | ea |
| 06-6 | H1 | 011-2011 | H001-0829596 | | 112011 | PIN, stght, hdls, cold-fin, S, 1/8 x 1/8..... | 1 | ea |
| 06-6 | H6 | | H006-0214310 | | 137404 | CONNECTOR, flared tube, inverted, br, 3/16 tube, 1/8 male pipe end | 2 | ea |
| 06-6 | | 2920-353-7216 | G740-7375373 | AL-IAU49 WO-118733 | 7375373 | COVER, distributor and coil..... | 1 | ea |
| 06-6 | | 5305-737-5371 | G740-7375371 | AL-8X3029 WO-118724 | 7375371 | SCREW, int-teeth-lock washer, fil-hd, S, cd- or zn-pltd, No. 10-32NF x 11/16 | 6 | ea |
| 01-2, 4; 03-8; 06-6 | | | G758-7358569 | DR-X20488 WO-808421 | 7358569 | DISTRIBUTOR, w/COIL, assy (optional w/DISTRIBUTOR 7358569) | 1 | ea |
| | | | G758-7358569 | AL-IAU4006AUT WO-806380 | 7358569 | DISTRIBUTOR, w/COIL, assy (optional w/DISTRIBUTOR DR-X20488) | 1 | ea |
| | H1 | | H101-9409107 | | 9409107 | BOLT, MACHINE, hex-hd, w/spring lock washer, S, cd- or zn-pltd, 1/4-20NC-2 x 3/8 | 1 | ea |
| | H1 | 5310-C12-0392 | H001-7043681 | | 120392 | WASHER, flat, light series, S, cd- or zn-pltd, 1/4 in..... | 1 | ea |
| 06-6 | | 2920-737-5110 | G740-7375110 | AL-IAH15 WO-117066 | 7375110 | GASKET, spark advance control arm..... | 1 | ea |

| | | | | | | | | |
|------|----|---------------|------------------------------|---|---|---|--------|----------|
| 06-6 | | | G7*1-7374885 | AL-IAU39 WO-118732 | 7374885 | HOLDER, breaker plate..... | 2 | ea |
| 06-6 | | 2920-358-8182 | G741-7374878 | AL-IAU24 WO-118730 AL-RX2731 AL-IGB132 AL-IGB26 | 7374878 | LEAD, ELECTRICAL, breaker lever to coil, assy..... Composed of: 1 CABLE 1 TERMINAL 1 TERMINAL | 1 | ea |
| 06-6 | H1 | 012-0614 | H001-4135681 | | 120614 | NUT, PLAIN, HEXAGON, S, cd- or zn-pltd, No. 10-32NC-2 | 2 | ea |
| 06-6 | H1 | 5310-043-1680 | H101-0431680 | | 431680 | WASHER, LOCK, med, S, tin-pltd, No. 10..... | 2 | ea |
| 06-6 | H2 | | H002-0501223 | | 501223 | PACKING, "O" ring, class B material (high flexibility) % ₁₆ ID, % ₃₂ thk (cover plug (1), receptacle mtg (1)) | 2 | ea |
| 06-6 | H2 | 054-6880 | H002-0546880 | | 546880 | PACKING, PREFORMED, "O" ring, syn-ru, 4% ₄ ID, 4% ₂ OD (cover) | 1 | ea |
| 06-6 | | 2920-353-7204 | G741-7374887 | AL-IAU1004 WO-118714 AL-IAU2004 | 7374887 | PLATE, breaker..... | 1 | ea |
| | | | | | | PLATE, breaker, assy..... Composed of: 1 CAPACITOR 1 CLIP 1 LEAD 1 PLATE 1 POINT SET 1 SCREW 1 SCREW 1 SCREW 1 WASHER 1 WASHER | 1 | ea |
| | | | | AL-IGC175 | 7374881 5346775 7374878 7374887 5346774 | | | |
| | | | | | 131875 131949 113014 500494 591400 | | | |
| 06-6 | H1 | | H101-0591400 | | 591400 | SCREW, int-teeth-lock washer, fil-hd, S, cd- or zn-pltd, No. 10-32NF-2 x % ₁₆ | 2 | ea |
| 06-6 | | 4730-353-7217 | G741-7374888 | AL-IAU54 WO-118735 | 7374888 | PLUG, hex-hd, br, cd-pltd, % ₁₆ -18NF-2 (distributor end coil cover) | 1 | ea |
| 06-6 | H6 | 011-8831 | H006-0283192 | | 118831 | PLUG, PIPE, sltd-hdls, br, pl-fin, % ₈ -27NPT (distributor base) | 1 | ea |
| 06-6 | | 2805-353-7215 | G741-7347547 | AL-IAU41 WO-118737 | 7347547 | PLUG, sq-hd, washer, br, cd-pltd, No. 10-32NF-2 (base drain) | 1 | ea |
| 06-6 | | 2926-423-4553 | G116-0400060 G507-5346774 | AL-IGP3028 AL-IGP3028FS WO-A1687 | 5346774 | POINT, stationary contact..... POINT SET, breaker..... | 1 1 | ea ea |
| | | | | | 7329386 | Composed of: 1 BRACKET 1 POINT | | |
| 06-6 | H1 | | H101-0455210 | AL-IGP3028 | 455210 | SCREW, mach, w/int-teeth lock washer, fil-hd, S, cd- or zn-pltd, Sems type, No. 8-32NC-2 x % ₁₆ | 1 | ea |

0604.1

150

| (1) ILLUSTRATION NO. | (2) REFER- ENCE SYMBOLS | (3) FEDERAL STOCK NO. | (4) ORDNANCE STOCK NO. | (5) MFR'S PART NO. | (6) ORDNANCE PART NO. | (7) DESCRIPTION | (8) QUANTITY INCOR- PORATED IN UNIT | (9) UNIT OF ISSUE |
|---|----------------------------------|-----------------------------|------------------------------|---|-----------------------------|--|---|----------------------------|
| GROUP 06—ELECTRICAL SYSTEM—Continued | | | | | | | | |
| 0604.1—DISTRIBUTOR—Continued | | | | | | | | |
| 06-6 | | | G758-8329786 | AL-IAU63 WO-119055 | 8329786 | RECEPTACLE, wiring harness, br, cd-pltd..... | 1 | ea |
| 06-6 | H1 | | H101-0455215 | | 455215 | SCREW, int-teeth-lock washer, fl-hd, S, cd-pltd, No. 6-32NC-2 x 1½/2 | 4 | ea |
| 06-6 | | 5340-358-7638 | G507-5346767 | AL-IG680 WO-A1653 | 5346767 | RING, retn, cam..... | 1 | ea |
| 06-6 | | 2920-353-7208 | G740-7348578 | AL-IAU1066 WO-118879 | 7348578 | ROTOR..... | 1 | ea |
| 06-6 | | | G741-8328076 | AL-IAU62 WO-119054 | 8328076 | SEAL, connector terminal..... | 1 | ea |
| 06-6 | H13 | | H013-7351671 | | 7351671 | SEAL, oil, ML type, 0.756 OD, 1/8 ID, 0.500 shaft dia (base) | 1 | ea |
| 06-6 | | 2920-737-5376 | G740-7375376 | AL-IAU1002L WO-118713 | 7375376 | SHAFT, drive..... | 1 | ea |
| 06-6 | | 5310-534-6768 | G507-5346768 | AL-IGS99 WO-A1672 | 5346768 | SPACER, S, 0.316 ID, 0.5625 OD, 0.150 thk (breaker cam to shaft weight plate) | 1 | ea |
| 06-6 | | 5340-353-7255 | G740-7412960 | AL-IGT69 WO-A1684 | 7412960 | SPRING, anti-rattle, breaker cam..... | 1 | ea |
| 06-6 | | 2920-358-7826 | G741-7374893 | AL-IAU29 WO-118731 | 7374893 | SPRING, cap..... | 1 | ea |
| 06-6 | | | 2980-IGB-284 G136-7376393 | AL-IGB284 AL-IGB284S WO-119988 | 7376393 | SPRING, governor weight..... SPRING SET, governor weight..... | 2 1 | ea ea |
| | | 5340-361-7935 | G716-7347355 | AL-IGB284 AL-IAT55 WO-637615 AL-IGB132 | 7347355 | Composed of: 2 SPRING SPRING, tension, drive shaft..... | 1 | ea |
| | | | | AL-IGB26 | | TERMINAL, cable, solder, eyelet dble-ear, hole for No. 10 screw (breaker plate capacitor (1), breaker plate to coil cable (1)) | 2 | ea |
| 06-6 | | | | AL-IAU10 WO-118736 | | TERMINAL, cable, solder, roll, dble-ear, RH (receptacle capacitor (1), breaker plate to coil cable (1)) | 2 | ea |
| 06-6 | | 5310-358-8169 | G741-7346969 | AL-IAU42 WO-118738 | 7346969 | WASHER, cork, 1/16 ID, 23/32 OD, 1/2 thk (drive shaft)..... WASHER, flat, cop, 13/64 ID, 3/8 OD, 0.032 thk (base drain plug) | 1 1 | ea ea |

| | | | | | | | | |
|----------|----|---------------|--------------|---|---------|---|---|----|
| 06-6 | | 3120-358-8178 | G741-7374895 | AL-IAH13 WO-117064 | 7374895 | WASHER, FLAT, thrust, S, cd-pltd $1\frac{1}{4}$ ID, $1\frac{1}{2}$ OD, $\frac{1}{2}$ thk (advance control plate) | 1 | ea |
| 06-6 | | 5310-358-8168 | G741-7374894 | AL-IAU52 WO-118734 | 7374894 | WASHER, neoprene, $\frac{1}{2}$ ID, $2\frac{3}{4}$ OD, $\frac{3}{4}$ thk (cap) | 4 | ea |
| 06-6 | | 3120-360-4556 | G507-5307283 | AL-IG90 WO-106740 | 5307283 | WASHER, thrust, S, 0.505 ID, 0.7968 OD, 0.032 thk (drive shaft, lower) | 1 | ea |
| 06-6 | | 350-0843 | G160-7980860 | AL-IG313 WO-117090 | 7980860 | WASHER, thrust, S, 0.505 ID, 1.0 OD, 0.032 thk (drive shaft, upper) | 1 | ea |
| 06-6 | | 2920-495-3301 | G503-7706790 | AL-IGC2168L WO-A9314 | 7706790 | WEIGHT, governor | 2 | ea |
| 06-6 | | | G758-8329787 | AL-GT97 WO-108874 | 8329787 | WICK, oil, base (felt) | 1 | ea |
| 06-6 | | 5330-362-1413 | G507-5346784 | AL-IGH28 WO-A1671 | 5346784 | WICK, oil, cam sleeve, washer type, felt | 1 | ea |
| | | | | | | 0605-IGNITION COIL WIRING AND SPARK PLUGS | | |
| 06-7, 11 | | | G758-8328449 | GE-331B151 TI-C57901-2600 WO-806262 | 8328449 | CABLE, distributor to spark plug, assy | 4 | ea |
| | | | | | | Composed of: | | |
| | | | | | | 1 CABLE | | |
| | | | | | | 1 CONDUIT | | |
| | | | | | | 2 FERRULE | | |
| | | | | | | 2 INSULATOR | | |
| | | | | | | 2 NUT | | |
| | | | | | | 2 PIN | | |
| | | | | | | 2 SLEEVE | | |
| | | | | | | 2 SPRING | | |
| 06-7 | H5 | | H005-0812387 | | 812337 | CABLE, 5-mm high tension, 29 $\frac{1}{8}$ lg, AXS-1308, rev 3, type 1, grade B, class 2, high-low temp, 0.191 min OD, 0.206 max OD | 4 | ea |
| | | | | | | 7528197 | | |
| | | | | | | 7528193 | | |
| | | | | | | 7526949 | | |
| | | | | | | 7528187 | | |
| | | | | | | 7526940 | | |
| | | | | | | 7526951 | | |
| | | | | | | 7526961 | | |
| | | | | | | 812337 | | |
| | | | | | | 7528200 | | |
| | | | | | | 8329738 | | |
| | | | | | | 8329737 | | |
| 06-6 | H2 | 2920-737-4882 | G741-7374882 | AL-CT4002 WO-118712 | 7374882 | CLAMP, open, spark plug to oil filter mtg bracket | 1 | ea |
| 06-6 | H1 | | H101-0455214 | | 455214 | CLIP, open, ignition cables to rocker arm cover studs | 3 | ea |
| 06-7 | | | | TI-S159-1864 | 7528197 | COIL, ignition (part of DISTRIBUTOR 7358569 sub-group 0604.1) | 1 | ea |
| 06-7 | | | | TI-U1864-20A | 7528193 | SCREW, mach, w/int-teeth-lock washer, fil-hd, S, cd-or zn-pltd, Sems type, No. 10-32NC-2 x $\frac{1}{16}$ | 2 | ea |
| 06-7 | H2 | | H102-0150189 | | 150189 | CONDUIT, flex, shielding, br, inner core, silicon-bz wire braid, $\frac{3}{4}$ nom size, 0.281 ID, 0.455 OD (26 lg) | 4 | ea |
| 06-7 | H4 | 752-6949 | H004-7526949 | | 7526949 | FERRULE, br (cable) | 8 | ea |
| 06-7 | | | | TI-A23377 | 7528187 | GASKET, annular, cop, oval-sec, 14-mm | 4 | ea |
| | | | | | | INSULATOR, silicone, 0.204 ID, 0.281 OD, 0.4890 shoulder, 2.030 ID (spark plug cable connector) | 8 | ea |
| | | | | | | NUT, hex, br, corr-res, S, $1\frac{1}{16}$ -24NEF-3 | 8 | ea |

| (1) ILLUSTRATION NO. | (2) REFER- ENCE SYMBOLS | (3) FEDERAL STOCK NO. | (4) ORDNANCE STOCK NO. | (5) MFR'S PART NO. | (6) ORDNANCE PART NO. | (7) DESCRIPTION | (8) QUANTITY INCOR- PORATED IN UNIT | (9) UNIT OF ISSUE |
|--|----------------------------------|-----------------------------|------------------------------|-------------------------------------|---|--|---|----------------------------|
| GROUP 06—ELECTRICAL SYSTEM—Continued | | | | | | | | |
| 0605—IGNITION COIL WIRING AND SPARK PLUGS—Continued | | | | | | | | |
| 06-7 | H4 | 752-6940 | H004-7526940 | | 7526940 | PIN, rd-hd, br, 0.037 OD, 0.406 lg (cable, distributor to spark plug) | 8 | ea |
| 01-3, 4 | H4 | | H004-8357724 | | 8357724 | PLUG, spark, shielded, 14-mm, 1 $\frac{3}{16}$ hex, 3 $\frac{5}{32}$ overall (radio suppression wtrprf type) | 4 | ea |
| 06-7 | H4 | 752-6951 | H004-7526951 | | 7526951 | SLEEVE, spark plug cable, assy | 8 | ea |
| 06-7 | H4 | 752-6961 | H004-7526961 | | 7526961 | SPRING, compression, w/CAP, assy (0.312 ID, 0.495 OD, $\frac{2}{64}$ free lg) (spark plug cable connector) | 8 | ea |
| | | | | TI-A25785 TI-A25786 TI-A25784 | | Composed of: 1 CAP 1 CAP 1 SPRING | | |
| 0607—INSTRUMENT PANEL | | | | | | | | |
| | | | G742-7728854 | AC-1501244 SW-504A WO-118102 | 7728854 | AMMETER, 24 v, wtrprf, assy (used on vehicles through serial No. 70114) (used w/CLUSTER 7418835) | 1 | ea |
| 06-9; 18-6 | | | G758-8376378 | AC-1501476 WO-811246 | 8376378 | AMMETER, 24 v, wtrprf, assy (used on vehicles after serial No. 70114 (used w/CLUSTER 8376619) | 1 | ea |
| 06-9 | | | | GL-5939768 WO-118165 | 7384390 | BODY, head light beam indicator light (M38A1) | 1 | ea |
| 06-10 | | | | UCI-160339 | 7358620 | BODY, high beam indicator light (1), instrument cluster lights (2), assy (M170) | 3 | ea |
| 06-9 | | | | AC-5939764 WO-118167 | 7385244 | BODY, instrument cluster light | 2 | ea |
| | | | | | | BODY, instrument cluster light, assy | 2 | ea |
| | | | | | 7385245 | BRACKET, body, instrument cluster light | 4 | ea |
| | | | | | 435857 | RIVET, SOLID, fl-hd, S, anld, zn-fin, $\frac{1}{8}$ x $\frac{1}{4}$ | 4 | ea |
| | | | | WO-801460 | 7726808 | BRACKET, circuit closure, assy (for No. 85 ignition switch circuit) | 1 | ea |
| | | | | | | Composed of: 1 BRACKET 1 GROMMET 1 SHELL 1 TERMINAL | | |
| | | | | | 7726804 573004 573007 7524913 7726804 | BRACKET, connector (circuit closure cap) | 1 | ea |
| | | 2520-772-6804 | G244-7726804 | WO-801977 | | | | |

| | | | | | | | |
|-------|----|---------------|-------------------------------------|---------|---|---|----|
| | | | UCI-160334-1 | 7358623 | BRACKET, mtg (instrument panel (2), high beam indicator lights (1)) (M170) | 3 | ea |
| 06-9 | | 6680-737-2727 | G742-7372727 | 7372727 | BRACKET, mtg, speedometer (M38A1)..... | 1 | ea |
| 06-9 | H1 | 042-6915 | H101-0426915 | 426915 | NUT, plain, hex, S, cd- or zn-pltd, No. 8-36NF-2..... | 2 | ea |
| 06-9 | H1 | 013-1182 | H001-7023591 | 131182 | WASHER, lock, S, cd- or zn-fin, No. 8..... | 2 | ea |
| 06-10 | | | AL-26267 | | BRACKET, mtg, speedometer (M170)..... | 1 | ea |
| 06-10 | | | AL-2235 | | NUT, plain, hex, S, cd- or zn-pltd, No. 10-32NF..... | 2 | ea |
| 06-10 | H1 | | H101-0431680 | 431680 | WASHER, lock, S, cd- or zn-fin, No. 10..... | 2 | ea |
| 06-9 | H4 | | H004-0572999 | 572999 | BUSHING, terminal (instrument cluster harness (4), headlight beam indicator light (1), instrument cluster light (2)) | 7 | ea |
| 06-9 | H5 | | H005-0812364 | 812364 | CABLE, automotive, low tension, ins. (plastic, natural or syn-ru) wtrprf, sgle-cond, stranded, shielded, cond size AWG No. 14, OD 0.160 in. | † | ft |
| | | 2510-753-9519 | G742-7539519 | 7539519 | CASE, gage resistor, w/TERMINAL and RESISTOR, assy | 3 | ea |
| 06-9 | | | AC-1507502 WO-118922 | 7529480 | CLAMP, gage mtg (ammeter (1), fuel gage (1), oil pressure (1), water temperature (1)) | 4 | ea |
| | | | AC-1501207 RO-481N1 WO-119051 | | | | |
| 06-9 | H1 | 042-6915 | H101-0426915 | 426915 | NUT, plain, hex, S, cd- or zn-pltd, No. 8-36NF-2..... | 8 | ea |
| 06-9 | H1 | 013-1182 | H001-7023591 | 131182 | WASHER, lock, S, cd- or zn-fin, No. 8..... | 8 | ea |
| 06-10 | | | AL-26269 | | CLAMP, mtg, instrument (ammeter (1), fuel gage (1), oil pressure (1), water temperature (1)) | 4 | ea |
| 06-10 | | | AL-2235 | | NUT, plain, hex, S, cd- or zn-pltd, No. 10-32NF..... | 8 | ea |
| 06-10 | H1 | | H101-0431680 | 431680 | WASHER, lock, S, cd- or zn-fin, No. 10..... | 8 | ea |
| | | 5340-752-6595 | G741-7526595 | 7526595 | CLIP, open, tension type, 0.812 OD, connector, hole for ¼ screw (panel light 3 wire connector) | 1 | ea |
| 06-10 | | | AL-L7930 | 7954878 | CLUSTER, instrument (optional w/CLUSTER 7954879) (M170) | 1 | ea |
| | | | AC-1582314 WO-809828 | | | | |
| | | | AC-1582371 SW-502V WO-808569 | 7954879 | CLUSTER, instrument (optional w/CLUSTER 7954878) (M170) | 1 | ea |
| | | 6680-741-8835 | G740-7418835 | 7418835 | CLUSTER, instrument, assy (used on vehicles up to serial No. 70114) (M38A1) | 1 | ea |
| | | | AC-1582076 SW-502F WO-806363 | | | | |
| | | | AC-1582890 SW-502Z WO-811243 | 8376619 | CLUSTER, instrument, assy (used on vehicles after serial No. 70114) (M38A1) | 1 | ea |
| | | 5935-776-0598 | G244-7760598 | 7760598 | CONNECTOR, elec cable, wtrprf, male, No. 14 AWG cable, assy (instrument cluster harness (4), headlight beam indicator light (1)) | 5 | ea |
| | | | WO-800422 | | Composed of: | | |
| | | | | 572999 | 1 BUSHING | | |
| | | | | 573005 | 1 GROMMET | | |
| | | | | 573007 | 1 SHELL | | |
| | | | | 572929 | 1 TERMINAL | | |

0607

154

| (1) ILLUSTRATION NO. | (2) REFER- ENCE SYMBOLS | (3) FEDERAL STOCK NO. | (4) ORDNANCE STOCK NO. | (5) MFR'S PART NO. | (6) ORDNANCE PART NO. | (7) DESCRIPTION | (8) QUANTITY INGOR- PORATED IN UNIT | (9) UNIT OF ISSUE |
|---|----------------------------------|-----------------------------|------------------------------|--|-----------------------------|--|---|----------------------------|
| GROUP 06—ELECTRICAL SYSTEM—Continued | | | | | | | | |
| 0607—INSTRUMENT PANEL—Continued | | | | | | | | |
| 06-9 | H4 | 350-9273 | H004-0573000 | | 573000 | CONNECTOR, sleeve (inside) (instrument cluster harness) | 4 | ea |
| 06-9 | | | G742-7384389 | WO-118166 | 7384389 | COVER, high beam light..... | 1 | ea |
| 06-9 | | | G742-7384392 | GL-5989765 WO-118168 | 7384392 | COVER, panel light..... | 2 | ea |
| 06-10; 18-7 | | | G742-8376377 | SHA-9805-20-00 WO-800393 | 8376377 | FASTENER, shakeproof (instrument cluster to instru- ment panel) | 4 | ea |
| | | | | AL-EO-12207 WO-809823 AC-1501463 SW-504E WO-808503 | | GAGE, battery and generator, w/CLAMP, assy (used w/CLUSTER 7954878 or 7954879) (M170) | 1 | ea |
| 06-9; 18-6 | | | G742-7728852 | AC-1517561 SW-505C WO-119084 | 7728852 | GAGE, fuel, 24 v, wtrprf, w/CLAMP and RESISTOR, assy (used w/CLUSTER 7418835) (M38A1) | 1 | ea |
| 16-10, 18-7 | | | G742-8376374 | AC-1517871 SW-505J WO-808519 | 8376374 | GAGE, fuel, 24 v, wtrprf, w/CLAMP and RESISTOR, assy (used w/CLUSTER 8376619 or 7954879) | 1 | ea |
| 06-9, 18-6 | | | G742-8376374 | AL-EO-12204 WO-809817 | 8376374 | GAGE, fuel, 24 v, waterproof, w/CLAMP and RESIS- TOR, assy (used w/CLUSTER 7954878) | 1 | ea |
| 06-9, 18-6 | | | G742-7728853 | AC-1507680 SW-505B WO-119085 | 7728853 | GAGE, oil pressure, 24 v, wtrprf, w/CLAMP and RESIS- TOR, assy (used w/CLUSTER 7418835) | 1 | ea |
| 06-9, 18-6 | | | G758-8376380 | AC-1508003 SW-505P WO-811245 | 8376380 | GAGE, oil pressure, 24 v, wtrprf, w/CLAMP and RESIS- TOR (used w/CLUSTER 8376619) | 1 | ea |
| 06-10, 18-7 | | | G742-7954230 | AL-EO-11932 WO-809821 AC-1507975 SW-505L WO-808445 | 7954230 | GAGE, oil pressure, 24 v, waterproof, w/CLAMP and RESISTOR, assy (used w/CLUSTER 7954878 or 7954879) | 1 | ea |
| 06-9, 18-6 | | 6685-738-9567 | G742-7389567 | AC-1512422 SW-505A WO-119086 | 7389567 | GAGE, water temperature, 24 v, wtrprf, w/CLAMP and RESISTOR, assy (used w/CLUSTER 7418835) | 1 | ea |
| 06-9, 18-6 | | | G758-8376379 | AC-1512669 SW-505N WO-811244 | 8376379 | GAGE, water temperature, 24 v, wtrprf, w/CLAMP and RESISTOR, assy (used w/CLUSTER 8376619) (M38A1) | 1 | ea |

155

0607

| | | | | | | | | |
|----------------|----|---------------|--------------|--|---------|---|---|----|
| 06-10, 18-7 | | | G742-7954511 | AL-EO-11933 WO-809822 AC-1512676 SW-505K WO-808568 | 7954511 | GAGE, water temperature, 24 v, wtrprf, w/CLAMP and RESISTOR, assy (used w/CLUSTER 7954878 or 7954879) | 1 | ea |
| 06-10 | | | | UCI-C4394 | 7358626 | GASKET, neoprene (instrument cluster (2), and high beam indicator lights (1); (M170) | 3 | ea |
| | H4 | | H004-0573004 | | 573004 | GROMMET, connector, No. 12 AWG cable (circuit closure cap) | 1 | ea |
| | H4 | | H004-0573005 | | 573005 | GROMMET, connector, 14 GA (0.160 dia) wire (instrument cluster harness (4), head light beam indicator light (1)) | 5 | ea |
| 06-9 | H4 | | H004-0573002 | | 573002 | GROMMET, connector, two No. 14 AWG cable (used w/SHELL 573008) | 1 | ea |
| 06-9, 11 | | 2510-752-6600 | G741-7526600 | AC-1580684 SW-418113 WO-118106 | 7526600 | HARNESS, instrument cluster, assy (used w/CLUSTER 7418835 or 8376619) (M38A1) | 1 | ea |
| | | | | | | Composed of: ‡ CABLE 4 CONNECTOR 4 MARKER 4 SLEEVE | | |
| 06-10, 12 | | | G742-7526601 | AC-1580690 AL-EX100008 WO-808622 | 7526601 | HARNESS, instrument cluster, assy (used w/CLUSTER 7954878 or 7954879) (M170) | 1 | ea |
| 06-9 | H4 | 6240-019-0877 | H104-0190877 | | 190877 | LAMP, incand, 24-28 v, 0.263 amp (sgle contact bulb, clear, 2 tun-fil) (used w/CLUSTER 7418835 or 8376619) (M38A1) | 3 | ea |
| 06-10 | | | | | 454732 | LAMP, head light beam indicator light (panel (2), indicator high beam (1)) (used w/CLUSTER 7954878 or 7954879) (M170) | 3 | ea |
| 06-9 | | | G742-7384388 | GL-5939750 WO-118115 UCI-160338 | 7384388 | LENS, instrument panel and high beam lights (red glass) (used w/CLUSTER 7418835 or 8376619) (M38A1) | 3 | ea |
| | | | | | 7358621 | LENS, instrument panel (2) and high beam lights (1) (ruby red glass) (M170) | 3 | ea |
| | | 6220-538-1088 | G503-5381088 | DR-1903433 WO-800452 | 5381088 | LEVER, ignition switch, w/WASHER, assy | 1 | ea |
| | H1 | 5305-013-1963 | H001-5125831 | | 131963 | BOLT, MACHINE, fil-hd, S, cd- or zn-pltd, No. 8-32NC-2A x 3/8 | 1 | ea |
| | H1 | | H101-0453299 | | 453299 | WASHER, lock, med, cd-pltd, No. 8 | 1 | ea |
| | | 6220-776-0418 | G742-7760418 | GL-928562 SW-418112 WO-118113 | 7760418 | LIGHT, high beam indicator, 24 v, wtrprf, assy (used w/CLUSTER 7418835 or 8376619) (M38A1) | 1 | ea |
| 06-9 | H1 | 013-1970 | H001-5125851 | | 131970 | SCREW, mach, fil-hd, S, cd- or zn-pltd, No. 8-32NC-2A x 1/2 | 2 | ea |
| 06-9 | H1 | 012-1841 | H001-7025591 | | 121841 | WASHER, lock, med, S, cd- or zn-pltd, No. 8 | 2 | ea |

0607

156

| (1) ILLUSTRATION NO. | (2) REFER- ENCE SYMBOLS | (3) FEDERAL STOCK NO. | (4) ORDNANCE STOCK NO. | (5) MFR'S PART NO. | (6) ORDNANCE PART NO. | (7) DESCRIPTION | (8) QUANTITY INGOR- PORATED IN UNIT | (9) UNIT OF ISSUE |
|---|----------------------------------|-----------------------------|------------------------------|--------------------------------------|-----------------------------|---|---|----------------------------|
| GROUP 06—ELECTRICAL SYSTEM—Continued | | | | | | | | |
| 0607—INSTRUMENT PANEL—Continued | | | | | | | | |
| 18-7 | | | G749-7358619 | AL-EOC11931 WO-808565 | 7358619 | LIGHT, indicator, head light beam, assy (used w/CLUSTER 7954878 or 7954879) (M170) | 2 | ea |
| 06-10 | | | | AL-8X304 | | SCREW, mach, rd-hd, S, cd or zn-pltd, No. 8-32NC-2A x $\frac{5}{16}$ | 2 | ea |
| 06-10 | | | | AL-12X195 | | WASHER, lock, med, S, cd or zn-pltd, No. 8 (0.164) | 2 | ea |
| 18-6 | | 6220-776-0412 | G742-7760412 | GL-929358 SW-419106 WO-119093 | 7760412 | LIGHT, instrument cluster, 24-28 v, wtrprf, assy (used w/CLUSTER 7418835 or 8376619) (M38A1) | 2 | ea |
| 06-9 | H1 | | H001-5147521 | | 121749 | SCREW, mach, rd-hd, S, cd- or zn-pltd, No. 8-32NC-2 x $\frac{5}{16}$ | 4 | ea |
| 06-9 | H1 | 012-1841 | H001-7025591 | | 121841 | WASHER, lock, med, S, cd- or zn-pltd, No. 8 | 4 | ea |
| 18-7 | | | G260-7358618 | AL-EOC11930 WO-808566 | 7358618 | LIGHT, instrument panel, assy (used w/CLUSTER 7954878 or 7954879) (M170) | 2 | ea |
| 06-10 | | | | AL-8X304 | | SCREW, mach, rd-hd, S, cd- or zn-pltd, No. 8-32NC-2A x $\frac{5}{16}$ | 2 | ea |
| 06-10 | | | | AL-12X195 | | WASHER, lock, med, S, cd- or zn-pltd, No. 8 (0.164) | 2 | ea |
| | | 2530-752-4649 | G252-7524649 | WO-801692 | 7524649 | MARKER, circuit number | 8 | ea |
| | | 2540-741-2641 | G740-7412641 | WO-804639 | 7412641 | PLATE, ignition switch (br) | 1 | ea |
| 06-9 | | | | AC-1582077 SW-418100 WO-119367 | | PLATE, mtg, instrument panel, assy (used w/CLUSTER 7418835 or 8376619) (M38A1) | 1 | ea |
| | | | | AC-1582372 WO-119956 | | PLATE, mtg, instrument panel, assy (used w/CLUSTER 7954879) (M170) | 1 | ea |
| 06-10; 18-7 | | | | AL-26809 WO-809829 | | PLATE, mtg, instrument panel, assy (used w/CLUSTER 7954878) (M170) | 1 | ea |
| 06-10 | H2 | | H002-7526590 | | 7526590 | STUD, instrument cluster mtg plate | 4 | ea |
| 06-10 | | 5310-752-6591 | G742-7526591 | AL-EX94032 WO-118100 | 7526591 | WASHER, retainer, instrument panel mtg | 4 | ea |
| | | | | G742-7539516 | 7539516 | RESISTOR, gage 95 ohm (instrument cluster) | 3 | ea |
| 06-9 | H4 | 350-9280 | H004-0573008 | | 573008 | SHELL, female, connector (mates w/SHELL, 573009) | 1 | ea |
| | H4 | 350-9279 | H004-0573007 | | 573007 | SHELL, female, connector (mates w/SHELL, 573010) (instrument cluster harness (4), head light beam indicator light (1), circuit closure cap (1)) | 6 | ea |
| 06-10 | | | | UCI-160334-9 | | SHIELD, high beam indicator light (M170) | 1 | ea |
| 06-9 | | 2510-752-6596 | G741-7526596 | AC-1580836 SW-418107 WO-118110 | 7526596 | SHIELD, instrument panel light (used w/CLUSTER 7418835 or 8376619) (M38A1) | 2 | ea |

| | | | | | | | |
|----------|----|---------------|--------------|---------|--|---|----|
| 06-10 | | | UCI-160334-8 | | SHIELD, instrument panel light (M170)..... | 2 | ea |
| 06-9 | H4 | | H004-0573126 | 573126 | SLEEVE, w/CONNECTOR, assy..... | 1 | ea |
| | | | G742-7539517 | 7539517 | SPRING, contact, gage resistor (instrument cluster)..... | 3 | ea |
| 06-9, 10 | H2 | | H002-7526590 | 7526590 | STUD, instrument cluster mtg plate..... | 4 | ea |
| 06-9 | | 5305-752-6594 | G741-7526594 | 7526594 | STUD, mtg, wiring harness (used w/CLUSTER 7418835, or 8376619, or 7954879) (M38A1) | 1 | ea |
| 06-10 | | | AC-1580890 | | | | |
| | | | SW-418104 | | | | |
| | | | WO-118107 | | | | |
| | | | AL-EX96034 | | STUD, mtg, wiring harness (used w/CLUSTER 7954878)..... | 1 | ea |
| | | | WO-809830 | | | | |
| 06-11, | | 5930-776-0409 | G742-7760409 | 7760409 | SWITCH, ignition, wtrprf, w/CABLES, assy..... | 1 | ea |
| 18-6 | | | DR-1997856 | | | | |
| | | 737-2738 | G742-7372738 | 7372738 | NUT, hex, thin, S, cd- or zn-pltd, 1/2-20NF-2..... | 1 | ea |
| | | | DR-1913360 | | | | |
| | | | WO-118163 | | | | |
| | H1 | | H101-0453804 | 453804 | SCREW, mach, fil-hd, S, zn-dichromate-fin, No. 8- 32NC-2 x 3/8 | 1 | ea |
| | H1 | | H101-0453813 | 453813 | WASHER, lock, int-teeth, S, zn-dichromate-fin, 1/2 in. | 1 | ea |
| 06-8; | | | G749-7368702 | 7368702 | SWITCH, light, 24 v, wtrprf, assy..... | 1 | ea |
| 18-6 | | | UCI-160306 | | | | |
| | | | WO-806450 | | | | |
| | H1 | | H101-0454787 | 454787 | SCREW, mach, w/int-teeth-lock washer, pan-hd, cross- recess, S, cd- or zn-pltd, header-pt, No. 10-32NF x 1/2 | 4 | ea |
| | | 5940-752-4913 | G244-7524913 | 7524913 | TERMINAL, non-conductor (circuit closure cap)..... | 1 | ea |
| | H4 | | H004-0572929 | 572929 | TERMINAL, wire, No. 14 AWG (0.160 dia) (instrument cluster harness (4), head light beam indicator light (1)) | 5 | ea |
| 06-9 | H1 | | H101-0446152 | 446152 | WASHER, flat, S, cd-pltd, 0.203 ID, 1/2 OD (mtg harness, outer) (used w/CLUSTER, 7418835 and 8376619) | 1 | ea |
| 06-9 | | 5310-752-6592 | G741-7526592 | 7526592 | WASHER, FLAT, S, cd-pltd, 0.322 ID, 0.582 OD, 0.0329 thk (mounting, harness, inner) (used w/CLUSTER 7418835 and 8376619) (M38A1) | 1 | ea |
| 06-10 | | | AL-EX100417 | | WASHER, mounting harness, inner, (used w/CLUSTER 7954878) (M170) | 1 | ea |
| | | | WO-809831 | | | | |
| 06-10 | | | AL-EX96172 | | WASHER, mounting harness, outer (used w/CLUSTER 7954878) (M170) | 1 | ea |
| | | | WO-809832 | | | | |
| 06-9 | | 5310-752-6591 | G742-7526591 | 7526591 | WASHER, retaining, instrument panel mtg stud..... | 4 | ea |
| | | | AC-1580678 | | | | |
| | | | SW-418102 | | | | |
| | | | WO-118100 | | | | |
| | | | WO-804784 | | | | |
| 06-11; | | | G742-7728788 | 7728788 | CABLE, stop light switch, assy..... | 1 | ea |
| 18-6 | | | DM-6579 | | SWITCH, head light dimmer, w/CABLES, assy..... | 1 | ea |
| | | | WO-649726 | | | | |
| | H1 | | H101-0454789 | 454789 | SCREW, mach, w/int-teeth lock washer, truss-hd, cross- recess, S, cd- or zn-pltd, header-pt, 1/4-20UNC x 1/2 | 2 | ea |
| 06-11 | | 5930-741-2642 | G742-7388813 | 7388813 | SWITCH, stop light, hyd, 24 v, wtrprf, assy..... | 1 | ea |
| | | | FS-7332 | | | | |
| | | | WO-804783 | | | | |
| | | | G740-7416521 | 7416521 | SWITCH, stop light, hyd, 24 v, wtrprf, w/CABLES, assy..... | 1 | ea |
| | | | WO-805574 | | | | |

0608 - MISCELLANEOUS SWITCHES

0609.1

158

| (1) ILLUSTRATION NO. | (2) REFERENCE SYMBOLS | (3) FEDERAL STOCK NO. | (4) ORDNANCE STOCK NO. | (5) MFR'S PART NO. | (6) ORDNANCE PART NO. | (7) DESCRIPTION | (8) QUANTITY INCORPORATED IN UNIT | (9) UNIT OF ISSUE |
|---|--------------------------|--------------------------|---------------------------|-------------------------|--------------------------------------|---|--------------------------------------|----------------------|
| GROUP 06—ELECTRICAL SYSTEM—Continued | | | | | | | | |
| 0609.1—HEAD, TAIL, AND MARKER LIGHTS | | | | | | | | |
| 06-14 | | 2520-776-5214 | G260-7765214 | AL-CB17413 WO-118456 | 7765214 | BODY, blackout head light, assy..... | 1 | ea |
| 06-17 | | 6220-368-4945 | G742-7529242 | AL-CB17364 WO-118453 | 7529242 | BODY, right tail light, assy..... | 1 | ea |
| 06-12, 14, 15, 16, 17 | H4 | | H004-0572999 | | 572999 | BUSHING, grommet adapting, wtrprf cable connector, No. 14 AWG cable (head light, left (3), right (3), head light cable, left (3), right (3), blackout head light (2), blackout head light cable (3), blackout marker light (2), tail light, left (3), right (2), right blackout marker light to head light cable (2)) | 26 | ea |
| 06-13, 14, 15, 16, 17 | H5 | | H005-0812364 | | 812364 15-C-2165- 170 | CABLE, automotive, low tension, ins, wtrprf, sgle-cond, cond size AWG No. 14, 0.160 OD (head light, left, right; blackout head light, blackout head light cable, blackout marker light, tail light, left, right) | 1 | ft |
| 06-11, 14 | | | | AL-CB17891 WO-118459 | | CABLE, extension, assy (blackout driving light)..... | 1 | ea |
| 06-11, 15 | | | | AL-CB18499 WO-118467 | | CABLE, left head light, assy..... | 1 | ea |
| 06-11, 15 | | | | AL-CB18500 WO-118468 | | CABLE, right head light, assy..... | 1 | ea |
| | | 5935-776-2750 | G256-7762750 | | 7762750 | CONNECTOR, 3-wire (left and right head light cable and left blackout marker light cable to light switch harness) | 3 | ea |
| | | 5935-776-0598 | G244-7760598 | WO-800422 | 7760598 | CONNECTOR, elec cable, wtrprf, male, No. 14 AWG cable, assy (head light cable, left (3), right (3), blackout head light (2), blackout head light cable (1), blackout marker light (2), tail light, left (3), right (2)) | 16 | ea |
| | | | | | 572999 573005 573007 572929 | Composed of: 1 BUSHING 1 GROMMET 1 SHELL 1 TERMINAL | | |
| | H4 | | H004-7760599 | | 7760599 | CONNECTOR, female, type PCA, 14 AWG cable terminal, assy (head light, left (3), right (3), blackout head light cable (2)) | 8 | ea |
| | | | | | 572999 573000 | Composed of: 1 BUSHING 1 CONNECTOR | | |

159

0609.1

| | | | | | | | | |
|-------|----|--------------------------------|------------------------------|--------------------------------------|---|---|--------|----------|
| 06-13 | | 2510-772-9796 | G244-7729796 | HAC-21325 WO-118155 | 573005 573010 572929 7729796 | 1 GROMMET 1 SHELL 1 TERMINAL CONNECTOR, lamp, w/CABLE, assy (blackout marker light) | 2 | ea |
| 06-13 | | 5305-772-9797 | G244-7729797 | HAC-21216F1 WO-118157 | 7729797 | SCREW, shoulder, oval-hd, sltd, S, cd- or zn-pltd, No. 6-32NC-2 x 1 $\frac{3}{16}$ (blackout marker light) | 4 | ea |
| 06-13 | | 5310-772-9799 5935-353-0952 | G251-7729799 G251-7526028 | WO-119510 AL-CB17371 WO-118447 | 7729799 7526028 | WASHER, blackout marker light cable..... CONNECTOR, left tail light, assy..... | 4 1 | ea ea |
| | | | | | 812364 7526000 7526002 7526022 7524649 7526003 7525999 135974 7525998 7526023 7526027 7526001 7729798 572929 7526026 7526289 121832 | Composed of: † CABLE 3 CONTACT 1 GROMMET. 1 GROMMET 3 MARKER 1 PLATE 1 PLATE 2 RIVET 1 SLEEVE 1 SOCKET 2 SPRING 1 SPRING 2 TERMINAL 3 TERMINAL 2 WASHER 1 WASHER SCREW, MACH, S, rd-hd, sltd, No. 8-32NC-2 x $\frac{3}{8}$ | | |
| 06-16 | H1 | 012-1832 5935-353-0955 | H001-5147531 G251-7526005 | AL-CB17370 WO-118454 | 7526005 | CONNECTOR, right tail light, assy..... | 7 1 | ea ea |
| | | | | | 812364 7526000 7526002 7526004 7524649 7526003 7525999 135974 7525998 7526001 572929 7729798 7526289 121832 | Composed of: † CABLE 2 CONTACT 1 GROMMET 1 GROMMET 2 MARKER 1 PLATE 2 PLATE 2 RIVET 2 SLEEVE 2 SPRING 2 TERMINAL 2 TERMINAL 2 WASHER SCREW, MACHINE, S, rd-hd, sltd, No. 8-32NC-2 x $\frac{3}{8}$ | | |
| 06-17 | H1 | 012-1832 | H001-5147531 | | 121832 | | 7 | ea |

0609.1

160

| (1) ILLUSTRATION NO. | (2) REFER- ENCE SYMBOLS | (3) FEDERAL STOCK NO. | (4) ORDNANCE STOCK NO. | (5) MFR'S PART NO. | (6) ORDNANCE PART NO. | (7) DESCRIPTION | (8) QUANTITY INCOR- PORATED IN UNIT | (9) UNIT OF ISSUE |
|---|----------------------------------|-----------------------------|------------------------------|-------------------------|-----------------------------|--|---|----------------------------|
| GROUP 06—ELECTRICAL SYSTEM—Continued | | | | | | | | |
| 0609.1 — HEAD, TAIL, AND MARKER LIGHTS | | | | | | | | |
| —Continued | | | | | | | | |
| 06-14, 15 | H4 | 350-9273 | H004-0573000 | | 573000 | CONNECTOR, wtrprf cable, assy (inside) (blackout head light cable (2), head light cable, left (3), right (3), right blackout marker light to right head light cable (1)) | 9 | ea |
| 06-16 | | | | GL-5938368 | 7526000 | CONTACT, cable, style No. 2 (blackout tail and stop light, left (3), right (2)) | 5 | ea |
| 06-14 | | | G742-7525940 | AL-CB17398 WO-118460 | 7525940 | DOOR, blackout head light, assy..... | 1 | ea |
| 06-14 | | 6220-752-5939 | G251-7525939 | CC-1273326 | 7525939 | RING, retaining, treated, S, wire, 3/4 dia stock, 1/8 in. opening | 3 | ea |
| 06-14 | | 5305-752-5938 | G251-7525938 | CC-1273325 | 7525938 | SCREW, sp, fil-hd, S, No. 8 (0.164)-32NC x 3/8..... | 3 | ea |
| 06-13 | | 6220-772-9791 | G244-7729791 | HAC-21208 WO-118153 | 7729791 | DOOR, blackout marker light, w/LENS, assy..... | 2 | ea |
| 06-13 | H1 | 5305-013-4225 | H101-0134225 | | 134225 | SCREW, MACHINE, oval-hd, S, phos-fin, No. 8-32NC-2A x 1/2 | 4 | ea |
| | | | | GL-5939696 IL-510220 | 7526019 | DOOR, blackout tail and stop light, left..... | 1 | ea |
| | | | | GL-5939715 IL-510221 | 7526017 | DOOR, blackout tail and stop light, right..... | 1 | ea |
| 06-16 | H4 | | H004-7526020 | | 7526020 | DOOR, blackout tail light, assy (left)..... | 1 | ea |
| | | | | | 7526019 | Composed of: | | |
| | | | | | 7526015 | 1 DOOR | | |
| | | | | | 7526009 | 1 FILTER | | |
| | | | | | 7526012 | 1 GASKET | | |
| | | | | | 7526014 | 1 GASKET | | |
| | | | | | 7526013 | 1 LENS | | |
| | | | | | 7526021 | 1 LENS | | |
| | | | | | 7526008 | 1 PLATE | | |
| | | | | | 7526016 | 1 PLATE | | |
| | | | | | 7320642 | 6 RING | | |
| | | | | | 7375694 | 6 SCREW | | |
| 06-17 | H4 | | H004-7526018 | | 7526018 | DOOR, blackout tail light, assy (right)..... | 1 | ea |
| | | | | | 7526017 | Composed of: | | |
| | | | | | 7526010 | 1 DOOR | | |
| | | | | | | 1 FILTER | | |

| | | | | | | | | | | | |
|-------------------|----|--------------------------------|---------------|---|---|---|----|----|---|----|----|
| 06-15 | H1 | 6220-732-0642 5310-012-0217 | G742-7525936 | GL-5939781 WO-118472 | 7526015 7526009 7526012 7526014 7526013 7526011 7526016 7526008 7320642 7375694 7525936 | 1 FILTER 1 GASKET 1 GASKET 1 GASKET 1 LENS 1 LENS 1 PLATE 1 PLATE 6 RING 6 SCREW | 2 | ea | | | |
| | | | 6220-732-0642 | G251-7320642 | 7320642 | RING, screw, retaining | | | 6 | ea | |
| | | | G742-7539541 | GL-5939783 | 7525935 | SCREW | | | 6 | ea | |
| | | | H001-7025621 | | 120217 | WASHER, lock, med, S, cd- or zn-pltd, No. 10, 0.194 ID, 0.337 OD | | | 6 | ea | |
| | | | | | 145411 | FASTENER, clip (type B), S, phos-ctd, 3/8 in cable (right head light cable to deflectors) | | | 2 | ea | |
| | | | | G162-1449805 | GL-5933064 | 7526010 | | | FILTER, blackout tail light door, right (amber) | 1 | ea |
| | | | | | IL-5939713 | 7526015 | | | FILTER, blackout tail light lens, left and right | 2 | ea |
| | | | | | GL-5939713 | | | | | | |
| | | | | | HAC-21193 | 7729793 | | | GASKET, blackout marker light, door, left and right | 2 | ea |
| | | | | | WO-118160 | | | | | | |
| 06-13 | | 6220-772-9793 | G244-7729793 | IL-5935713 | 7526009 | GASKET, blackout tail light, door, filter, left and right | 2 | ea | | | |
| | | | | GL-5935713 | | | | | | | |
| | | | | GL-5939700 | 7526014 | GASKET, blackout tail light, door, lower lens, left and right | 2 | ea | | | |
| | | | | IL-5939700 | | | | | | | |
| | | GL-5939697 | 7526012 | GASKET, blackout tail light, door, upper lens, left and right | 2 | ea | | | | | |
| | | IL-5939697 | | | | | | | | | |
| | | 6220-353-0941 | G740-7375024 | AL-CB18509 | 7375024 | GASKET, service head light, door, left and right | 2 | ea | | | |
| | | | | WO-118925 | | | | | | | |
| 06-16, 17 | H4 | 5325-735-3590 | H004-7320658 | | 7320658 | GASKET, tail light door, left and right | 2 | ea | | | |
| | | | G262-7353590 | | 7353590 | GROMMET, blackout marker light cable hole (left and right) | 2 | ea | | | |
| 06-14, 15, 16, 17 | H4 | | H004-0573005 | | 573005 | GROMMET, connector, No. 14 AWG, 0.160 dia wire (headlight left (3), right (3), head light cable, left (3), right (3), blackout marker light (2), tail light, left (3), right (2), blackout head light (2), blackout head light cable (3)) | 24 | ea | | | |
| | | | H004-0573001 | | 573001 | GROMMET, connector, 3-wire, 14 AWG, assy (left and right head light cable and left blackout marker light cable to light switch harness) | 3 | ea | | | |
| | | | | | 7762750 | Composed of: | | | | | |
| | | | | | 7762751 | 1 CONNECTOR | | | | | |
| | | | | | 7762687 | 1 SLEEVE | | | | | |
| | | | | | | 3 SPRING | | | | | |

0609.1

| (1) ILLUSTRATION NO. | (2) REFER- ENCE SYMBOLS | (3) FEDERAL STOCK NO. | (4) ORDNANCE STOCK NO. | (5) MFR'S PART NO. | (6) ORDNANCE PART NO. | (7) DESCRIPTION | (8) QUANTITY INCOR- PORATED IN UNIT | (9) UNIT OF ISSUE |
|---|----------------------------------|-----------------------------|------------------------------|--|-----------------------------|--|---|----------------------------|
| GROUP 06—ELECTRICAL SYSTEM—Continued | | | | | | | | |
| 0609.1—HEAD, TAIL, AND MARKER LIGHTS | | | | | | | | |
| —Continued | | | | | | | | |
| 06-17 | | | | GL-5939719 IL-5939719 IHC-103299K1 | 7526004 | GROMMET, left and right tail light socket and wiring, assy | 2 | ea |
| 06-16, 17 | | | G251-7526007 | AL-CB17633 IL-510214 WO-118448 | 7526007 | GROMMET, left and right tail light socket, w/EYE-LET, assy | 8 | ea |
| 06-14,15 | | 5325-752-5365 | G749-7526002 | GL-918888 | 7526002 | GROMMET, socket plate (tail light, left (1), right (1))... | 2 | ea |
| | | | G742-7525365 | AL-CB17499 WO-118923 | 7525365 | GROMMET, split, 3-hole, ru, 0.937 dia mtg groove, 1 1/2 wide (head light (2), blackout head light (1)) | 3 | ea |
| 06-16 | | | | IL-5939710 CC-1273357 GL-5939710 IHC-103305R1 | 7526022 | GROMMET (tail light, left) | 1 | ea |
| | H4 | | H004-0573002 | | 573002 | GROMMET, wtrprf cable connector, 2 No. 14 AWG cables (left and right head light cable to light switch cable) | 3 | ea |
| 06-13 | H2 | | H002-0502852 | | 502852 | GROMMET, plain, ru, 3/16 ID, 5/16 dia, 1/16 wide mtg groove (blackout marker light, left and right) | 4 | ea |
| 06-13 | | | | HAC-21226 WO-118154 | 7729792 | HOUSING, blackout marker light (left and right) | 2 | ea |
| 06-15 | | | | AL-CB18510 WO-118464 | | HOUSING, head light, assy (left and right) | 2 | ea |
| 06-16 | | | | AL-CB17365 WO-118446 | | HOUSING, left tail light, w/stop LIGHT, assy | 1 | ea |
| 06-16 | H4 | | H104-0446914 | | 446914 | LAMP, elec, incand, min, 24-28 v, sgle-tun-fil, No. 1683, sgle-contact cand-bay-base, 32 cp (service stop) | 1 | ea |
| 06-13, 16, 17 | H4 | 6240-019-0877 | H104-0190877 | | 190877 | LAMP, incand, 24-28 v, 23 amp, sgle-contact, cand-bay-base, clear bulb, dble-tun-fil, 1 1/8 lg, 1000 hr (blackout marker light (2), tail light, left (2), right (2)) | 6 | ea |
| 06-14 | H4 | | H104-0451989 | | 451989 | LAMP-UNIT, sealed beam, blackout, includes wiring, waterseal, 24 v, 4 1/2 in. (blackout head light) | 1 | ea |
| 06-15 | | 6220-741-8343 | G740-7418343 | AL-CB19791 WO-119088 | 7418343 | LAMP-UNIT, sealed beam, head lamp, includes wiring, waterseal, 24 v, 7 in. (left and right head light) | 2 | ea |
| | | | | IL-5939701 GL-5939701 | 7526013 | LENS, blackout tail light door, lower, left and right | 2 | ea |
| | | | | IL-5939716 GL-5939716 | 7526011 | LENS, blackout tail light door, upper, right | 1 | ea |

162

183

0609.1

| | | | | | | | | |
|-----------------------------|----------|---------------|------------------------------|--|-------------------------------|---|----|----|
| 06-13; 18-1 | | | G244-7723899 | IL-5939695 GL-5939695 HAC-21780 WO-649692 | 7526021 7723899 | LENS, red, tail and stop light, upper, left..... | 1 | ea |
| 06-13 06-17; 18-4 | H1 H4 | | H101-0271187 H004-7760506 | | 271187 7760506 | LIGHT, blackout marker, assy (left and right)..... | 2 | ea |
| 06-14, 18-1 | H1 | | H101-9409110 | | 9409110 | NUT, hex, w/ext-lock washer, Keps type, 5/16-24NF-3..... | 2 | ea |
| 06-14 | H4 | | H004-7760505 | | 7760505 | LIGHT, blackout tail and stop, 24-28 v, right, assy..... | 1 | ea |
| 06-14 | H1 | 013-4566 | H001-4135821 | | 134566 | BOLT, hex-hd, S, cd- or zn-pltd, w/spring lock washer, 3/8-16NC-2A x 5/8 | 4 | ea |
| 06-14 | H1 | 5310-012-0382 | H001-7025741 | | 120382 | LIGHT, head, blackout, sealed beam, assy..... | 1 | ea |
| 18-1 | | | | WO-118924 | | WASHER, lock, med, S, cd- or zn-pltd, 3/8 in..... | 1 | ea |
| 18-1 | | | | AL-2-15-3-50 WO-802429 WO-908767 | 8673513 | LIGHT, head, blackout, shielded, wtrprf, 24-28 v, w/o CABLES, assy | 1 | ea |
| 18-1 | | 6220-776-0504 | G741-7760504 | AL-2-15-4-50 WO-802430 | 7760504 | LIGHT, head, left, assy (w/o DOOR)..... | 1 | ea |
| 06-15 06-16; 18-4 | | 6220-776-0503 | G742-7760503 | WO-908768 WO-118927 | 7760503 | LIGHT, head, right, assy (w/o DOOR)..... | 1 | ea |
| 06-13, 14, 15, 16, 17 | H4 | | H004-7760507 | | 7760507 | LIGHT, head, service, 24 v, wtrprf, w/o CABLES, assy..... | 2 | ea |
| 06-15 | | | G252-7524649 | WO-801692 | 7524649 | LIGHT, tail and stop, 24-28 v, left, assy..... | 1 | ea |
| 06-13 | | | | WO-801692 | | MARKER, circuit (head light, left (3), right (3), head light cable, left (6), right (8), blackout head light (2), blackout head light cable (4), blackout marker (2), tail light, left (3), right (2)) | 33 | ea |
| 06-16, 17 | | | | AL-CB17811 WO-118465 | | MOUNTING, sealed beam unit, head light, assy (left and right) | 2 | ea |
| 06-16, 17 | | 6220-737-5022 | G740-7375023 G740-7375022 | WO-800378 WO-801860 GL-5939709 | 7375023 7375022 7526003 | PAD, mtg, blackout marker light (ru) (left and right)..... | 2 | ea |
| 06-16, 17 | | | | GL-5939703 | 7526016 | PAD, mtg, head light (ru) (left and right)..... | 2 | ea |
| 06-16, 17 | | | | IL-5939730 GL-5939730 | 7526008 | PLATE, baffle (blackout tail and stop, left (1) and right (1)) | 2 | ea |
| 06-16, 17 | | | | GL-5939708 IL-5939708 | 7525999 | PLATE, clinch, blackout tail light door, lower lens, left and right | 2 | ea |
| 06-16, 17 | | | | IL-5939730 GL-5939730 | 7526008 | PLATE, clinch, blackout tail light door, upper lens, left and right | 2 | ea |
| 06-16, 17 | | | | GL-5939708 IL-5939708 | 7525999 | PLATE, socket (blackout tail and stop light, left (1) and right (2)) | 3 | ea |
| 06-13 06-15 | | 5935-772-9802 | G244-7729802 G506-7538582 | | 7729802 7538582 | PLUG, blackout marker light cable hole..... | 2 | ea |
| 06-15 | | | | AL-CB17812 GL-5932467 WO-118469 | | RING, retn, service head light lamp-unit, left and right..... | 2 | ea |
| 06-15 | | | | AL-CB17814 WO-118470 | | RIVET, head light, mtg unit retn spring (left and right)..... | 4 | ea |

0609.1

| (1) ILLUSTRATION NO. | (2) REFER- ENCE SYMBOLS | (3) FEDERAL STOCK NO. | (4) ORDNANCE STOCK NO. | (5) MFR'S PART NO. | (6) ORDNANCE PART NO. | (7) DESCRIPTION | (8) QUANTITY INCOR- PORATED IN UNIT | (9) UNIT OF ISSUE |
|---|----------------------------------|-----------------------------|------------------------------|-------------------------|-------------------------------|--|---|----------------------------|
| GROUP 06—ELECTRICAL SYSTEM—Continued | | | | | | | | |
| 0609.1—HEAD, TAIL, AND MARKER LIGHTS | | | | | | | | |
| —Continued | | | | | | | | |
| | H1 | 5320-011-1870 | H001-0936130 | | 111870 | RIVET, TUBULAR, oval-hd, S, $\frac{1}{8}$ x $\frac{1}{8}$ (head light housing, left (6), right (6) and blackout head light (4)) | 16 | ea |
| 06-15 | | 5305-353-0969 | G506-7538146 | AL-CB9944 WO-118471 | 538146 | SCREW, S, cd-pltd, $\frac{1}{4}$ -28NF-3 x $1\frac{3}{16}$ (focusing, service head light lamp-unit, right and left) | 4 | ea |
| 06-16, 17 | | 5305-737-5694 | G744-7375694 | | 7375694 | SCREW, mach, rd-hd, S, No. 10-24NC-1 $\frac{1}{32}$ (blackout tail light door, left and right) | 12 | ea |
| 06-16, 17 | | 6220-732-0642 | G251-7320642 | | 7320642 | RING, screw retn, S, 0.047 stk (blackout tail light door, left and right) | 12 | ea |
| 06-15 | H1 | | H101-0454783 | | 454783 | SCREW, mach, w/int-teeth lock washer, cross-recess, pan-hd, header-pt, S, cd- or zn-pltd, No. 10-24NC x $\frac{1}{2}$ (headlight to guard, left (8), right (8)) | 16 | ea |
| 06-14, 15 16, 17 | H4 | 350-9279 | H004-0573007 | | 573007 | SHELL, female, connector, 1 cable (2 wire) (mates w/SHELL 573010) (head light, left (3), right (3), head light cable, left (3), right (3), blackout head light (2), blackout head light cable (1), blackout marker light (2), tail light, left (3), right (2)) | 22 | ea |
| | H4 | 350-9280 | H004-0573008 | | 573008 | SHELL, female, connector, 2 cable (mates w/SHELL 573009) (left and right head light cable and left blackout marker cable to light switch harness) | 3 | ea |
| 06-14, 15 | H4 | 350-9282 | H004-0573010 | | 573010 | SHELL, male, connector, 1 cable (2 wire) (mates w/SHELL 573007) (head light cable, left (3), right (3), left blackout head light cable (2), right blackout marker light cable to head light cable (1)) | 9 | ea |
| | | 2570-776-2751 | G256-7762751 | | 7762751 | SLEEVE, connector cover (left and right head light cable and left blackout marker light cable to light switch harness) | 3 | ea |
| 06-16, 17 | | | | CC-1273972 GL-923121 | 7525998 | SLEEVE, tail light socket (left (1) and right (2)) | 3 | ea |
| 06-16 | | 5935-752-6023 | G742-7526023 | GL-5939705 | 7526023 | SOCKET, w/PLATE, assy (left tail light) | 1 | ea |
| | | | | | 7526025 6210568 7729798 | Composed of: 1 PLATE 1 SOCKET 1 TERMINAL | | |
| 06-16 | | | G067-0905540 | | 7526027 | SPRING, compression, music wire, $\frac{1}{32}$ dia, $2\frac{3}{64}$ OD, 3 $\frac{1}{2}$ coils, $\frac{3}{8}$ free lgh | 2 | ea |
| 06-14 | | | G742-7525937 | AL-CB258 WO-642233 | 7525937 | SPRING, retn, blackout head light sealed beam unit | 3 | ea |

164

| | | | | | | | | |
|---------------------------------------|-----|---------------|-------------------------|--------------|---|---|------|----|
| 06-15 | | G505-0682454 | AL-CB6134 WO-117116 | | SPRING, retn, head light mtg unit (left (2), right (2))..... | 4 | ea | |
| | | 6220-447-3477 | G744-7712833 | 7712833 | SPRING, retn, service head light door gasket (left (5), right (5)) | 10 | ea | |
| | | 2510-776-2687 | G256-7762687 | 7762687 | SPRING, sleeve and connector (left and right head light cable and left blackout marker light cable to light switch harness) | 9 | ea | |
| 06-16, 17 | | | G260-7526001 | 7526001 | SPRING, tail light socket (left (1), right (2))..... | 3 | ea | |
| 06-13 | | | | 7353508 | SUPPORT, blackout marker light socket, left and right... | 2 | ea | |
| | H5 | | H005-0875945 | 17-T-1745-60 | TAPE, insulating, vinyl chloride, acetate, black, width $\frac{3}{4}$ in., thk 0.010 in. (ft per roll (108)) (blackout head light cable, head light cable, left, right) | † | roll | |
| 06-17 | | | GL-5937374 IL-520312 | 7729798 | TERMINAL, ground, br, 0.190 dia eyelet, 0.136 dia rivet hole (tail light, left (1), right (2)) | 3 | ea | |
| 06-17 | | | GM-135974 | 135974 | RIVET, tubular, oval-hd, br, ni-pltd, brgt, $\frac{1}{8}$ x $\frac{5}{32}$, $\frac{1}{32}$ dia | 3 | ea | |
| 06-14, 15 | II4 | | H004-7056708 | 7056708 | TERMINAL, WATERSEAL, type No. 1, No. 10 screw, No. 12 and No. 14 multi-conductor cable, cop, cd-pltd (head light cable, left (1), right (1), blackout head light (1)) | 3 | ea | |
| 06-13, 14, 15, 16, 17 | H4 | | H004-0572929 | 572929 | TERMINAL, wire, No. 14 AWG, 0.160 dia (blackout head light (2), blackout head light cable (3), blackout marker light (2), head light, left (3), right (3), head light cable, left (5), right (7), tail light left (3), right (2)) | 30 | ea | |
| 06-14 | | 5310-350-2655 | G749-5294507 | 5294507 | AL-CB17867 WO-118461 | WASHER, bearing, blackout head light..... | 1 | ea |
| 06-16 | | | G251-7526026 | 7526026 | WASHER, socket plate mtg (tail light, left)..... | 2 | ea | |
| 06-16, 17 | | 5310-752-6289 | G260-7526289 | 7526289 | WASHER, tail light socket, left (1), right (2)..... | 3 | ea | |
| 0609.2-AUXILIARY LIGHTS (M170) | | | | | | | | |
| | | | RBR-405D3 | | BLOCK, brush..... | 1 | ea | |
| | | | RBR-430D3 | | BLOCK, commutator, flood light, extn cable shaft..... | 1 | ea | |
| 06-18 | | | G244-7726808 | 7726808 | WO-801460 | BRACKET, circuit closure, assy..... | 1 | ea |
| | | | | 7726804 | Composed of: | | | |
| | | | | 573004 | 1 BRACKET | | | |
| | | | | 573007 | 1 GROMMET | | | |
| | | | | 7524913 | 1 SHELL | | | |
| | | | | 7726804 | 1 TERMINAL | | | |
| 06-18 | | | G244-7726804 | 7726804 | CC-1271718 WO-801977 | BRACKET, connector (circuit closure cap)..... | 1 | ea |
| 06-18 | | | RBR-263D4 | | BRACKET, mounting..... | 1 | ea | |
| | | | RBR-840D4 | | BRUSH, silver plated..... | 2 | ea | |
| 06-18 | H4 | | H004-0572999 | 572999 | BUSHING, grommet adapting, wtrprf cable connector, No. 14 AWG cable | 2 | ea | |

0609.2

166

| (1) ILLUSTRATION NO. | (2) REFER- ENCE SYMBOLS | (3) FEDERAL STOCK NO. | (4) ORDNANCE STOCK NO. | (5) MFR'S PART NO. | (6) ORDNANCE PART NO. | (7) DESCRIPTION | (8) QUANTITY INCOR- PORATED IN UNIT | (9) UNIT OF ISSUE |
|---|----------------------------------|-----------------------------|------------------------------|------------------------|-----------------------------|--|---|----------------------------|
| GROUP 06—ELECTRICAL SYSTEM—Continued | | | | | | | | |
| 0609.2—AUXILIARY LIGHTS (M170)—Continued | | | | | | | | |
| 06-18 | | | | AXS-1819 SV-18/2 | 7732849 | CABLE, extension light..... | 1 | ea |
| 06-18 | H5 | | H005-0812364 | | 812364 | CABLE, automotive, low tension, ins (plastic, natural or syn-ru) wtrprf, sgle-cond, stranded, shielded, cond size AWG No. 14, OD 0.160 | 1 | ft |
| 06-18 | | | | RBR-202D3 | | CASE, outer..... | 1 | ea |
| | H4 | | H004-7760599 | | 7760599 | CONNECTOR, female, type PCA, 14 AWG cable, terminal Composed of: 1 BUSHING 1 GROMMET 1 SHELL 1 SLEEVE 1 TERMINAL | 1 | ea |
| 06-18 | | | G244-7760598 | WO-800422 | 7760598 | CONNECTOR, male, No. 14 AWG cable, terminal, assy.. Composed of: 1 BUSHING 1 GROMMET 1 SHELL 1 TERMINAL | 1 | ea |
| 06-18 | | | | RBR-404D4 WO-810895 | | COVER, terminal, flood light extension cable reel case..... EXTENSION, reel, assy..... | 1 1 | ea ea |
| | H4 | | H004-0573004 | | 573004 | GROMMET, wtrprf cable connector, No. 12 AWG cable (circuit closure cap) | 1 | ea |
| 06-18 | H4 | | H004-0573005 | | 573005 | GROMMET, wtrprf cable connector, No. 14 AWG cable.. | 1 | ea |
| 06-18 | | | | HC-DL12-3 | | HANDLE, wood, baked enamel finish..... | 1 | ea |
| 06-18 | | | | RBR-406D4 | | HOLDER, brush..... | 2 | ea |
| 06-18 | | | | HC-DL16-5 | | HOOK, flat, S..... | 1 | ea |
| 06-18 | | | | HC-DL16-4 | | HOOK, wire, S, cd-plate or parkerized, oil finish..... | 1 | ea |
| 06-18 | | | | WO-810894 | | LAMP, assy..... | 1 | ea |
| 06-18 | H4 | | H104-0193048 | | 193048 | LAMP, elec, incand, min, 24-28 v, sgle-tun-fil, No. 1204, 21 cp (dbl-contact cand-bay-base, S-8 bulb, C-2V fil) | 1 | ea |
| 06-18 | | | | RBR-203D3 | | LID, case..... | 1 | ea |
| 06-12, 18 | | | G741-7412783 | WO-810893 | 7412783 | LIGHT, extension, w/REEL..... | 1 | ea |
| 06-18 | | | G740-7372885 | WO-673600 | 7372885 | SCREW, assembled washer int-teeth lock washer, hex-hd, header-pt, S, cd- or zn-pltd, ¼-20NC x 5/8 (super- seded by SCREW 425380) | 2 | ea |

| | | | | | | | | |
|-------|----|---------------|--------------|------------|---------|---|---|----|
| | H1 | | H101-0425380 | | 425380 | SCREW, int-teeth lock washer, hex-hd, header-pt, S, cd- or zn-pltd, ¼-20NC-2 x ⅝ (supersedes SCREW 7372885) | 2 | ea |
| | H1 | 5310-017-4916 | H001-7124701 | | 174916 | WASHER, LOCK, int-ext-teeth, S, cd- or zn-pltd, ¼ x 0.760 (0.720 to 0.760 OD) (used for attaching screw through connection) | 1 | ea |
| 06-18 | | | G252-7524649 | WO-801692 | 7524649 | MARKER, circuit number (reel lamp cable) | 2 | ea |
| 06-18 | | | | RBR-204D4 | | NUT, hex | 1 | ea |
| | | | | RBR-417D4 | | PAWL, ratchet | 1 | ea |
| | | | | RBR-422D4 | | PIN, spring, ratchet | 1 | ea |
| | | | | RBR-421D4 | | PLATE, separator | 1 | ea |
| 06-18 | | | | RBR-273D4 | | PLATE, switch | 1 | ea |
| 06-18 | | | | RBR-201D3 | | PULLEY, lower half | 1 | ea |
| 06-18 | | | | RBR-200D3 | | PULLEY, upper half | 1 | ea |
| 06-18 | | | | RBR-432-D3 | | RATCHET | 1 | ea |
| 06-18 | | | | HC-DL12-2 | | REFLECTOR, br, ni-plate | 1 | ea |
| | | | | RBR-410D4 | | RING, inner, block, flood light extn cable shaft (silver pltd) | 2 | ea |
| | | | | RBR-411D4 | | RING, outer, block, flood light extn cable shaft (silver pltd) | 2 | ea |
| 06-18 | | | | RBR-276D4 | | RING, wire | 1 | ea |
| | | | | RBR-424D4 | | RIVET, brush | 2 | ea |
| | | | | RBR-425D4 | | RIVET, brush holder | 2 | ea |
| | | | | RBR-426D4 | | RIVET, brush block | 1 | ea |
| | | | | RBR-427D4 | | RIVET, fi-hd, S, 0.092 x 0.161 (flood light extn reel ratchet) | 1 | ea |
| 06-18 | | | | | 451785 | SCREW, binder head, slotted, machine | 4 | ea |
| 06-18 | | | G740-7372885 | WO-673600 | 7372885 | SCREW, int-teeth-lock washer, hex-hd, header-pt, S, cd- or zn-pltd, ¼-20NC-2 x ⅝ | 1 | ea |
| 06-18 | | | | | 145230 | SCREW, rd-hd, tapping | 1 | ea |
| 06-18 | | | | | 9407716 | SCREW, sh-metal, No. 4, binder head | 2 | ea |
| 06-18 | | | | RBR-274D4 | | SCREW, wood | 2 | ea |
| 06-18 | | | | RBR-209D3 | | SHAFT, main | 1 | ea |
| | H4 | | H004-0573007 | | 573007 | SHELL, wtrprf cable connector, female (mates w/SHELL 573010) (circuit closure cap) | 1 | ea |
| 06-18 | H4 | | H004-0573010 | | 573010 | SHELL, wtrprf cable connector, 1 cable, male (mates w/SHELL 573007) | 1 | ea |
| 06-18 | | | | RBR-428D4 | | SHIELD, fiber, flood light extension cable reel case | 1 | ea |
| 06-18 | H4 | | H004-0573000 | | 573000 | SLEEVE, waterproof cable connector | 2 | ea |
| 06-18 | | | | RBR-294D4 | | SPRING, clock | 1 | ea |
| | | | | RBR-419D4 | | SPRING, ratchet, compression, ¼ free lg (ratchet pawl, flood light extn reel) | 1 | ea |
| | | | | RBR-418D4 | | STUD, pivot, ratchet | 1 | ea |
| 06-18 | | | | RBR-264D4 | | SWITCH, toggle, push-in or slide type | 1 | ea |
| 06-18 | H4 | | H004-0572929 | | 572929 | TERMINAL, cable, snap, male, type 1, 15 amp, no. 14 AWG cable | 2 | ea |

0609.2

| (1) ILLUSTRATION NO. | (2) REFERENCE SYMBOLS | (3) FEDERAL STOCK NO. | (4) ORDNANCE STOCK NO. | (5) MFR'S PART NO. | (6) ORDNANCE PART NO. | (7) DESCRIPTION | (8) QUANTITY INCORPORATED IN UNIT | (9) UNIT OF ISSUE |
|---|--------------------------|--------------------------|------------------------------|--|--------------------------|--|--------------------------------------|----------------------|
| GROUP 06—ELECTRICAL SYSTEM—Continued | | | | | | | | |
| 0609.2—AUXILIARY LIGHTS (M170)—Continued | | | | | | | | |
| 06-18 | | 752-4913 | G244-7524913 | WO-801458 RBR-210D4 RBR-415D4 | 7524913 | TERMINAL, non-conductor (circuit closure cap)..... | 1 | ea |
| | | | | | | WASHER, shakeproof..... | 1 | ea |
| 06-18 | | | | RBR-265D4 RBR-266D4 | | WASHER, thrust, plain, S, $1\frac{1}{32}$ ID, $2\frac{1}{32}$ OD, 0.0825 thk (thrust, flood light extn cable shaft) | 1 | ea |
| | | | | | | WIRE, ground..... | 1 | ea |
| | | | | | | WIRE, power..... | 1 | ea |
| 0610—SENDING UNITS | | | | | | | | |
| | H6 | | H006-0214315 | | 137405 | CONNECTOR, flared tube, inverted, br, $\frac{1}{4}$ tube, $\frac{1}{8}$ male pipe end (optional w/CONNECTOR 145474) | 1 | ea |
| | H6 | | H006-0214551 | | 145474 | CONNECTOR, flared tube, inverted, S, cd- or zn-pltd, $\frac{1}{4}$ tube, $\frac{1}{8}$ male pipe end (optional w/CONNECTOR 137405) | 1 | ea |
| | H6 | | H106-0142735 | | 142735 | ELBOW, pipe, reducing, 90 deg, br, $\frac{1}{4}$ x $\frac{1}{8}$ (engine oil pressure unit) | 1 | ea |
| 03-9 | | 5330-737-5146 | G740-7375146 G758-8329686 | WO-648927 WO-806832 | 7375146 8329686 | GASKET, fuel level sending unit (cork)..... | 2 | ea |
| | H1 | 012-0367 | H001-4167521 | | 120367 | SUPPORT, oil pressure sending unit, w/BACKET, assy | 1 | ea |
| | H1 | 013-1395 | H101-0131395 | | 131395 | NUT, hex, lt, s-fin, S, cd- or zn-pltd, $\frac{1}{4}$ -28NF-2 (used on engines after serial No. 83923) | 2 | ea |
| | H1 | | H001-5417681 | | 121900 | NUT, PLAIN, sq, S, cd- or zn-pltd, $\frac{1}{4}$ -20NC-2..... | 1 | ea |
| | H1 | 5310-012-0380 | H001-7025681 | | 120380 | SCREW, cap, hex-hd, S, cd- or zn-pltd, $\frac{1}{4}$ -20NC-3 x 1. | 1 | ea |
| | | | G758-8333280 | AC-GG8799 WO-804319 AL-E011199F WO-812250 SW-507N WO-906054 | 8333280 | WASHER, lock, med, S, cd- or zn-pltd, $\frac{1}{4}$ in (used on engines after serial No. 83923) | 2 | ea |
| | | 6620-738-9566 | G742-7389566 | AC-1512423 WO-804873 WO-809816 | 7389566 | TRANSMITTER, liquid quantity (optional w/TRANS- MITTER AL-E011199F and SW-507N) (M170) | 1 | ea |
| | | | | | | TRANSMITTER, liquid quantity (optional w/TRANS- MITTER 8333280 and SW-507N) (M170) | 1 | ea |
| | | | | | | TRANSMITTER, liquid quantity (optional w/TRANS- MITTER 8333280 and AL-E011199F) (M170) | 1 | ea |
| | | | | | | UNIT, sending, engine water temperature, assy (op- tional w/UNIT WO-809816) | 1 | ea |
| | | | | | | UNIT, sending, engine water temperature, assy (op- tional w/UNIT 7389566) | 1 | ea |

188

169

0611

| | | | | | | | |
|------------------|---------------|--------------------------------|--|--------------------|--|---|----|
| 03-9, 03-11 | | G758-8329687 | SW-507F WO-810284 AC-1517756 DP-GG9096 WO-805914 | 8329687 | UNIT, sending, fuel level, assy (optional w/UNIT 8329687) | 1 | ea |
| 03-9 | 5305-281-1091 | G758-8332524 | WO-809251 | 8332524 | UNIT, sending, fuel level, assy (optional w/UNIT SW-507F) | 1 | ea |
| | 5305-270-7824 | G758-8332077 | WO-808137 | 8332077 | BOLT, ASSEMBLED WASHER, mach, cross-recess-pan-hd, S, cd- or zn-pltd, int-teeth lock washer, No. 8-32NC-2 x 1/2 (supersedes SCREW 8332077) | 5 | ea |
| | | | | | SCREW, ASSEMBLED WASHER, mach, cross-recess-pan-hd, S, cd- or zn-pltd, w/lock washer, No. 8-32NC-2 x 3/8 (superseded by BOLT 8332524) | 5 | ea |
| 01-2 | 6680-741-6363 | G742-7728856 | AC-1507492 SW-506B WO-800213 | 7728856 | UNIT, sending, oil pressure, 24 v, wtrprf, assy (M38A1) | 1 | ea |
| | | G742-7954231 | AC-1507980 WO-808567 AL-EOF11993 WO-809820 | 7954231 | UNIT, sending, oil pressure (M170) | 1 | ea |
| 0611-HORN | | | | | | | |
| 14-2 | | | RG-402141 WO-806915 | | ADAPTER, switch | 1 | ea |
| | H1 | 2540-734-8574 5305-741-8145 | G740-7348574 H101-9409107 | 7348574 9409107 | BRACKET | 1 | ea |
| | H4 | 5975-350-9272 | H004-0572999 | 572999 | BOLT, mach, w/lock washer, hex-hd, S, cd- or zn-pltd, 1/4-20NC x 5/8 | 2 | ea |
| | H5 | 6145-772-0853 | H005-0812364 | 15-C-2165-170 | BUSHING, terminal, grommet adapting, wtrprf cable connector, No. 14 AWG cable (horn switch) | 2 | ea |
| | | | | | CABLE, automotive-low tension, ins (plastic, natural, syn-ru) wtrprf, sgle cond, stranded, shielded, cond size, No. 14 AWG, 0.160 OD (horn switch) (8 in.) | † | ft |
| 14-2; 18-6 | | 2520-741-2442 | G740-7412442 | 7412442 | CAP, flexible (horn button) | 1 | ea |
| | H4 | 5935-350-9273 | H004-0573000 | 573000 | CONNECTOR, assy (inside) (horn switch) | 2 | ea |
| | H4 | | H004-7760599 | 7760599 | CONNECTOR, female, No. 14 AWG cable terminal, assy (horn switch) | 2 | ea |
| | | | | 572999 | Composed of: | | |
| | | | | 573000 | 1 BUSHING | | |
| | | | | 573005 | 1 CONNECTOR | | |
| | | | | 573010 | 1 GROMMET | | |
| | | | | 572929 | 1 SHELL | | |
| | | G758-8332677 | WO-809959 | 8332677 | 1 TERMINAL | | |
| | | | | | DISK, push rod, horn switch (centering) (used after vehicle serial No. 48124) | 1 | ea |
| 14-2 | | G758-8329688 | WO-806916 | 8329688 | GASKET, steering gear horn switch | 1 | ea |
| | H4 | 5325-350-9277 | H004-0573005 | 573005 | GROMMET, wtrprf cable connector, No. 14 AWG cable (0.160 dia) (horn switch) | 2 | ea |

| (1) ILLUSTRATION NO. | (2) REFERENCE SYMBOLS | (3) FEDERAL STOCK NO. | (4) ORDNANCE STOCK NO. | (5) MFR'S PART NO. | (6) ORDNANCE PART NO. | (7) DESCRIPTION | (8) QUANTITY INCORPORATED IN UNIT | (9) UNIT OF ISSUE |
|---|--------------------------|--------------------------|------------------------------|--------------------------|--------------------------|--|--------------------------------------|----------------------|
| GROUP 06—ELECTRICAL SYSTEM—Continued | | | | | | | | |
| 0611—HORN—Continued | | | | | | | | |
| | | 2540-735-1412 | G742-7728341 | AL-HX4001UT WO-800906 | 7728341 | HORN, elec, 24 v, waterproof, assy..... | 1 | ea |
| | H1 | 5305-012-3450 | H001-5418341 | | 123450 | BOLT, screw mach, hex-hd, S, cd- or zn-pltd, ¼-28NF-3 x ¾ | 2 | ea |
| | H1 | 5310-012-1753 | H001-7017621 | | 121753 | WASHER, lock, ext-teeth, S, cd- or zn-pltd, 0.494 OD, ¼ in. bolt size | 2 | ea |
| | | 2530-752-4649 | G252-7524649 G758-8332518 | WO-801692 WO-809173 | 7524649 8332518 | MARKER, circuit (horn switch)..... | 2 | ea |
| 14-2 | | | | WO-807112 | | RETAINER, button cap, S, cd- or zn-pltd, 1.281 ID, 0.020 thk | 1 | ea |
| | H4 | 5935-350-9282 | H004-0573010 | | 573010 | ROD, push, switch..... | 1 | ea |
| | | | | | | SHELL, male, connector, 1 cable (2 wire) (mates w/SHELL 573007) (horn switch) | 2 | ea |
| 14-2; 06-11 | | | G758-8329689 | WO-806412 | 8329689 | SWITCH, w/CABLE, assy..... | 1 | ea |
| | H5 | | H005-0875945 | | 17-T-1745-60 | TAPE, insulating, vinyl chloride acetate, black, width ¾ in., thk 0.010 in. (36 yd per roll) (horn switch) | ‡ | roll |
| | H4 | | H004-0572929 | | 572929 | TERMINAL, wire, No. 10-14 AWG (0.160 dia) (horn switch) | 2 | ea |
| 14-2 | | | G758-8329690 | WO-806393 | 8329690 | WASHER, retaining, switch, push rod..... | 1 | ea |
| 0612—BATTERIES AND CABLES | | | | | | | | |
| | | 249-9354 | 51 A-1562-255 | SPEC-OA111 WO-A11760 | 51-A-1562-255 | ACID, sulfuric, storage battery, dilute (electrolyte) special, sp-gr, 1.280 1-1 gal (imperial), container (in one package) | 1 | ea |
| | H15 | | H015-0572553 | | 572553 | BATTERY, storage, lead-acid, charged, dry, No. 2 HN (automotive service, 12 v, 6-cell, 45 amp-hr rating, 10⅞ x 5¼ x 8⅛ max) | 2 | ea |
| | H1 | 042-5388 | H101-0425388 | | 425388 | BOLT, integral lock washer, hex-hd, header-pt, S, cd- or zn-pltd, ⅝-18NC x ¾ (battery box to dash reinforcement) | 4 | ea |
| | H4 | | H004-0116300 | | 501924 | BOLT, battery terminal, sq-hd, S, ld-ctd, ⅝-18NC, w/NUT, (battery to ground cable (1), battery to battery cable (2), battery to starter cable (1)) | 4 | ea |
| | | | | BA-ZF1017 WO-684725 | | BRACKET, catch clamp (used on vehicles after serial No. 63252) | 1 | ea |
| | | | | WO-673438 | 8677261 | BRACKET, hanger, cowl battery box..... | 4 | ea |
| H1 | | 010-4249 | H001-0926132 | | 104249 | RIVET, solid, fl-hd, S, ¼ x ½..... | 8 | ea |

171

06-11

06-11

06-11

0612

| | | | | | | | |
|----|---------------|--------------|------------|---------|---|---|----|
| | | | WO-681758 | | BRACKET, retn, cowl battery hold-down..... | 4 | ea |
| | | | WO-680303 | | BRACKET, support, battery box to dash..... | 1 | ea |
| | | | WO-680301 | 8393195 | BRACKET, support, w/weld NUTS (welded) (battery box to dash) | 1 | ea |
| H1 | 042-5388 | H101-0425388 | | 425388 | BOLT, integral lock washer, hex-hd, header-pt, S, cd-or zn-pltd, $\frac{5}{16}$ -18NC x $\frac{3}{4}$ | 8 | ea |
| | | | WO-680307 | 8677551 | BRACKET, support, w/weld NUTS (welded) (battery box to instrument panel, inboard) | 1 | ea |
| H1 | 042-5388 | H101-0425388 | | 425388 | BOLT, integral lock washer, hex-hd, header-pt, S, cd-or zn-pltd, $\frac{5}{16}$ -18NC x $\frac{3}{4}$ | 7 | ea |
| | | | WO-680306 | | BRACKET, support, w/weld NUTS (welded) (battery box to instrument panel, outboard) | 1 | ea |
| H1 | 042-5388 | H101-0425388 | | 425388 | BOLT, integral lock washer, hex-hd, header-pt, S, cd-or zn-pltd, $\frac{5}{16}$ -18NC x $\frac{3}{4}$ | 7 | ea |
| H5 | | H005-0812370 | | 812370 | CABLE, automotive, low tension, ins, wtrprf, sgle-cond, stranded, cond size No. 2 AWG, 0.610 OD | † | ft |
| | | G758-8329663 | WO-806384 | 8329663 | CABLE, battery to battery, assy..... | 1 | ea |
| | | | | 812370 | Composed of: | | |
| | | | | 7056639 | † CABLE (5 in.) | | |
| | | | | 7412573 | 2 INSULATOR | | |
| | | | | | 2 MARKER | | |
| | | | | | 2 TERMINAL | | |
| | | G758-8329664 | PC-5292376 | 8329664 | CABLE, battery to ground, assy..... | 1 | ea |
| | | | WO-806389 | | Composed of: | | |
| | | | | 812370 | † CABLE (42 in.) | | |
| | | | | 7056639 | 2 INSULATOR | | |
| | | | | 7412573 | 2 MARKER | | |
| | | | | | 2 TERMINAL | | |
| H1 | 012-0758 | H001-5421241 | | 120758 | SCREW, mach, hex-hd, S, cd- or zn-pltd, $\frac{3}{8}$ -24NF-3 x $\frac{1}{8}$ (battery ground cable to frame) | 1 | ea |
| H1 | 5310-017-8551 | H001-7124741 | | 178551 | WASHER, lock, S, cd- or zn-pltd, No. 7, 0.965 OD, $\frac{3}{8}$ in. bolt size | 1 | ea |
| | | G758-8329665 | WO-806388 | 8329665 | CABLE, battery to starter, assy..... | 1 | ea |
| | | | | 812370 | Composed of: | | |
| | | | | 7056639 | † CABLE (25 in.) | | |
| | | | | 7412573 | 2 INSULATOR | | |
| | | | | | 2 MARKER | | |
| | | | | | 2 TERMINAL | | |
| | | | PC-5292376 | | CLAMP, catch, assy (used on vehicles after serial No. 63252) | 1 | ea |
| | | | WO-684724 | | Composed of: | | |
| | | | | | 1 BRACKET | | |
| | | | | | 1 CLAMP | | |
| | | | | | 1 LEVER | | |
| | | | | | 1 PIN | | |
| | | | | | 1 PIN | | |
| H1 | 010-4235 | H001-0926074 | WO-684725 | 104235 | RIVET, SOLID, fl-hd, S, $\frac{3}{16}$ x $\frac{1}{2}$ | 2 | ea |
| | | | WO-684729 | | | | |
| | | | WO-684726 | | | | |
| | | | WO-684727 | | | | |
| | | | WO-684728 | | | | |

| (1) ILLUSTRATION NO. | (2) REFERENCE SYMBOLS | (3) FEDERAL STOCK NO. | (4) ORDNANCE STOCK NO. | (5) MFR'S PART NO. | (6) ORDNANCE PART NO. | (7) DESCRIPTION | (8) QUANTITY INCORPORATED IN UNIT | (9) UNIT OF ISSUE |
|---|--------------------------|---------------------------|--|------------------------|------------------------------|---|--------------------------------------|----------------------|
| GROUP 06—ELECTRICAL SYSTEM—Continued | | | | | | | | |
| 0612—BATTERIES AND CABLES—Continued | | | | | | | | |
| | | | | WO-684729 | | CLASP, spring release, catch clamp (used on vehicles after serial No. 63252) | 1 | ea |
| | H4 | | H004-0327736 | | 120527 | CLIP, loop type, closed, $\frac{5}{8}$ hole for no. 10 screw (positive cable to dash (1); negative cable to dash (1), negative cable to splash apron (1)) | 3 | ea |
| | H1 | | H101-0454783 | | 454783 | SCREW, mach, w/int-teeth lock washer, pan-hd, cross-recess, S, cd- or zn-pltd, no. 10-24 NC x $\frac{1}{2}$ | 3 | ea |
| | H1 | 5305-734-6940 014-8313 | G758-8329666 G740-7346940 H101-0148813 | WO-807111 WO-640193 | 8329666 7346940 148313 | FRAME, hold-down, battery (welded) (under cowl)..... BOLT, clamp, battery, $\frac{5}{16}$ -18NC-3 x $8\frac{3}{4}$ NUT, plain, wing, S (formed), cd- or zn-pltd, $\frac{5}{16}$ -18NC-2 | 2 4 4 | ea ea ea |
| | H1 | 5310-012-0214 | H001-7025711 G503-7324833 | | 120214 7324833 | WASHER, lock, med, S, cd- or zn-pltd, $\frac{5}{16}$ in..... WASHER, lock, plain, S, cd- or zn-pltd, $2\frac{1}{4}$ x $\frac{5}{16}$ | 4 4 | ea ea |
| | H2 | | H102-0120013 | WO-52725 | 120013 | GROMMET, ru, split, $\frac{5}{8}$ ID, $2\frac{7}{32}$ OD, $\frac{1}{16}$ groove dia (battery cable through dash (2), battery ins boxes (2)) (used on vehicles through serial no. 14750) | 4 | ea |
| | | 5325-734-6945 | G740-7346945 | WO-801809 | 7346945 | GROMMET, ru, split, $\frac{3}{4}$ ID, $\frac{1}{16}$ groove dia (battery cable through dash (2), battery ins boxes (2)) (used on vehicles after serial no. 14750) | 4 | ea |
| | | 5970-705-6639 | G252-7056639 | WO-801697 | 7056639 | INSULATOR, plastic, 0.625 ID, 2.000 lg, 0.046 wall thkn (battery to ground cable (2), battery to battery cable (2), battery to starter (2)) | 6 | ea |
| | | | | WO-684726 | | LEVER, catch clamp (used on vehicles after serial no. 63252) | 1 | ea |
| | | | | WO-680382 | 8677636 | LID, battery box, assy (used on vehicles through serial no. 63252) | 1 | ea |
| | | | | WO-684731 | | LID, battery box, assy (welded) (used on vehicles after serial no. 63252) | 1 | ea |
| | | | | WO-684732 | | LID, battery box, w/CLAMP, assy (used on vehicles after serial no. 63252) | 1 | ea |
| | | 2540-741-2573 | G200-7412573 | WO-801694 | 7412573 431904 | MARKER, conduit, al-alloy, $\frac{1}{2}$ ID, 0.126 thk..... NUT, hex, lt, S, ld-ctd, $\frac{3}{8}$ -16NC-2 (battery post terminal) | 6 4 | ea ea |
| | H1 | | H101-8332063 | | 8332063 | NUT, push-on, type B, S, $\frac{5}{8}$ in. lg, $\frac{1}{2}$ in. wide, f/ $\frac{5}{16}$ stud (battery frame hold-down bolt) | 4 | ea |

| | | | | | | | | | |
|-----------|---------------|--------------|---|---------|---|--|----|----|--|
| H1 | 5305-016-1895 | H101-0161895 | WO-669904 | 8673999 | NUT, weld, S, $\frac{5}{16}$ -18NC (battery box support bracket to instrument panel (14), battery box support bracket to dash panel (8), battery box reinforcement (4)) | 26 | ea | | |
| | | | WO-680123 | 8677641 | PANEL, bottom, battery box..... | 1 | ea | | |
| | | | WO-680561 | 8677596 | PANEL, side, battery box, rear (at cowl)..... | 1 | ea | | |
| | | | ONB-SN1610 | 8677317 | NUT, weld, S, no. 10-24NC..... | 2 | ea | | |
| | | | WO-674898 | | | | | | |
| | | | | 161895 | | SCREW, tapping, thread forming, pan-hd, S, cd- or zn-pltd, no. 10 (0.191) x $\frac{1}{2}$ (battery box side panel to bottom to cowl) | 7 | ea | |
| | | | BA-ZL1005 | | PIN, clasp, catch clamp (used on vehicles after serial no. 63252) | 1 | ea | | |
| | | | WO-684727 | | PIN, lever, catch clamp (used on vehicles after serial no. 63252) | 1 | ea | | |
| | | | BA-ZL1006 | | | | | | |
| | | | WO-684728 | | | | | | |
| UC-48155 | 142083 | | PLUG, button, plain, S, $\frac{3}{8}$ dia hole (for 0.047 to 0.093 thk material) (painted) (radio cable hole in battery box) | 1 | ea | | | | |
| WO-806673 | | | | | | | | | |
| WO-680340 | 8393196 | | REINFORCEMENT, w/weld NUTS (welded) (battery box on dash panel) | 1 | ea | | | | |
| PK-P9419R | | | | | | | | | |
| WO-681166 | 8393223 | | SCREW, thumb, S, cd- or zn-pltd, $\frac{1}{4}$ -20NC-2 x 1 w/WASHER, (battery box door) (use through vehicles serial no. 63253) | 8 | ea | | | | |
| WO-680274 | | | STRAP, cowl battery box door hold-down (use on vehicles up to serial no. 63252) | 4 | ea | | | | |
| WO-684720 | | | STRAP, cowl battery box door hold-down (use after vehicles serial no. 63252) | 1 | ea | | | | |
| WO-680687 | 8393202 | | TEE, drain tube, S, battery box..... | 1 | ea | | | | |
| | 507032 | H004-0507032 | TERMINAL, battery, negative, w/clamp and lug attaching BOLTS and NUTS, assy | 2 | ea | | | | |
| H4 | | | | | | | | | |
| H4 | | H004-0507031 | | 507031 | TERMINAL, battery, positive, w/clamp and lug attaching BOLTS and NUTS, assy | 2 | ea | | |
| | | | | | | | | | |
| | | | PC-5292376 | | TERMINAL, cable, solder, lug, rd-end, cop, cd-pltd (battery to ground cable (2), battery to battery cable (2), battery to starter cable (2)) (superseded by TERMINAL PC-EX6686) | 6 | ea | | |
| | | | WO-802635 | | | | | | |
| | | | PC-EX6686 | | TERMINAL, cable, solder, rd-end, cop, tin-pltd (battery to ground cable (2), battery to battery cable (2), and battery to starter cable (2)) (supersedes TERMINAL PC-5292376) | 6 | ea | | |
| | | | WO-811911 | | | | | | |
| | | | WO-677786 | 8677545 | TRAY, battery box (welded) (at cowl)..... | 2 | ea | | |
| | | | WO-680479 | 8677554 | TUBE, drain, battery tray, ru..... | 1 | ea | | |
| | | | WO-680477 | 8393199 | TUBE, drain, battery tray, ru (inboard)..... | 1 | ea | | |
| | | | WO-680478 | 8677394 | TUBE, drain, battery tray, ru, (outboard)..... | 1 | ea | | |
| | | | WO-A4690 | 8393069 | TUBE, drain, S, battery box tray (use TUBING 44-T-5080-35 ($\frac{3}{8}$ lg)) | 2 | ea | | |
| | | | WO-680381 | 8393197 | WEATHERSTRIP, ru, 0.50 wide, 61.86 lg, 0.012 thk (cowl battery box door) | 1 | ea | | |

0613.1

| (1) ILLUSTRATION NO. | (2) REFERENCE SYMBOLS | (3) FEDERAL STOCK NO. | (4) ORDNANCE STOCK NO. | (5) MFR'S PART NO. | (6) ORDNANCE PART NO. | (7) DESCRIPTION | (8) QUANTITY INCORPORATED IN UNIT | (9) UNIT OF ISSUE | |
|---|--------------------------|--------------------------|---------------------------|--------------------------------------|-----------------------------|--|---|--|----|
| GROUP 06—ELECTRICAL SYSTEM—Continued | | | | | | | | | |
| 0613.1—CHASSIS WIRING | | | | | | | | | |
| 06-11 | H4 | 5975-350-9272 | G244-7726804 | WO-801977 | 7726804 | BRACKET, connector (ground connector to reel lamp) (M170) | 1 | ea | |
| | | | G244-7726808 | WO-801460 | 7726808 | BRACKET, assy (non-conductor) (M170) | 4 | ea | |
| | | | H004-0572999 | | 572999 | BUSHING, grommet adapting, wtrprf cable connector, No. 14 AWG cable (light switch harness (25), horn ground cable (1), fuel gage sending cable (2), voltage regulator harness (7)) | 35 | ea | |
| | | | 5340-772-2343 | G251-7722343 | SCI-10-40813-5 WO-801252 | 7722343 | BUSHING, RUBBER, elec, connector, 1-cable hole, 0.150 dia hole, 3/8 OD (voltage regulator harness) | 1 | ea |
| | | | G758-8329736 | GE-331B152 TI-C57993 WO-806409 | 8329736 | CABLE, assy (generator to generator regulator) | 1 | ea | |
| | H5 | 6145-705-6678 | H005-0812366 | | | 15-C-2165-200 | CABLE, automotive, low tension, ins (plastic, natural or syn-ru), wtrprf, sgle-cond, stranded, shielded, cond size AWG No. 12, 0.235 in OD (generator regulator harness) | ‡ | ft |
| | | | | | | 15-C-2165-250 | CABLE, automotive, low tension, ins (plastic, natural or syn-ru), wtrprf, sgle-cond, stranded, shielded, cond size AWG No. 8, 0.360 in OD (generator regulator harness) | ‡ | ft |
| | | | | | | 15-C-2165-170 | CABLE, automotive, low tension, ins (plastic, natural or syn-ru), wtrprf, sgle-cond, stranded, shielded, cond size AWG No. 14, 0.160 in OD (light switch cable, horn cable, generator regulator harness, fuel gage sending cable) | ‡ | ft |
| | | | | | | 7720853 | CABLE, 14 AWG (0.160 OD) (light switch, fuel gage and voltage regulator) | ‡ | ea |
| | | | | | | WO-806413 | 8677520 | CABLE, assy, fuel gage to sending unit | 1 |
| 06-12 | | | | WO-807196 | 7720853 | Composed of: | | | |
| | | | | | 7760599 | ‡ CABLE (99 in.) 1 CONNECTOR 1 LOOM (74 in.) 2 MARKER | | | |
| 06-12 | | | | WO-809261 | 7524649 | CABLE, fuel gage to sending unit, assy (M170) | 1 | ea | |
| | | | | | 7720853 | Composed of: | | | |
| | | | | | 7760599 | ‡ CABLE (96 in.) 1 CONNECTOR | | | |

174

| | | | | | | | |
|----------------|----|---------------|-------------------------|------------------------------|--|----|----|
| | | | PM-451 | | 1 LOOM (68 in.) 2 MARKER 2 TERMINAL | | |
| 06-11 | | | PO-5292274 WO-801529 | 7524649 572929 8677059 | CABLE, horn to ground, assy | 1 | ea |
| | H1 | 5310-012-0361 | H001-4135661 | 120361 | NUT, PLAIN, HEXAGON, S, cd- or zn-pltd, No. 10-24NC-2 (horn ground cable and blackout head light ground cable to fender) | 1 | ea |
| | H1 | | H101-0454783 | 454783 | SCREW, int-teeth-lock washer, cross-recess-pan-hd, S, cd- or zn-pltd, No. 10-24NC- x 1/2 | 1 | ea |
| | H1 | 5310-017-8378 | H001-7124621 | 178378 | WASHER, lock, int-ext-teeth, S, cd- or zn-pltd, No. 10 x 0.610 (0.580 to 0.610 OD) (used between horn cable terminal and fender) | 1 | ea |
| 06-11 | H4 | | H004-0327736 | 120527 | CLIP, closed loop, S, cd- or zn-pltd, 5/8 OD tube hole for 1/4 bolt (voltage regulator harness to dash (1), light switch harness (3)) | 4 | ea |
| | | | G252-7525934 | 7525934 | CLIP, connector (head light housing, left (3), right (3), blackout head light (2)) | 8 | ea |
| 06-11 | H4 | | H104-0145409 | 145409 | CLIP, fastener (type B) S, phos-ctd, 3/16 in. (blackout marker light cable to right radiator air deflector (1), horn and blackout driving lamp cable to fender splasher (1), light switch harness (1)) | 3 | ea |
| | H4 | | H104-0432653 | 432653 | CLIP, fastener (type B), S, cd- or zn-pltd, 3/8 in cable (head light cable to upper air deflector) | 2 | ea |
| 06-11 | | | G740-7047998 | WO-A5449 7047998 | CLIP, open, 5/16 dia hole for No. 10 screw (blackout head light cable to fender) | 1 | ea |
| | H1 | | H101-0454783 | 454783 | SCREW, mach, int-teeth-lock washer, cross-recess, pan-hd, header-pt, S, cd- or zn-pltd, No. 10-24NC x 1/2 | 1 | ea |
| 05-1; 06-11 | | 5940-734-3086 | G503-7343086 | WO-A5450 7343086 | CLIP, open, S, 1/16 hole for 3/8 bolt (head light cable to clip bracket (1), light switch rear harness to rear cross member (1), foot dimmer switch to dash (1)) | 3 | ea |
| | H1 | 012-0361 | H001-4135661 | 120361 | NUT, PLAIN, HEXAGON, S, cd- or zn-pltd, No. 10-24NC-2 (light switch rear harness to rear cross member (2), clip to radiator guard wiring clip bracket (1)) | 3 | ea |
| | H1 | | H101-0454783 | 454783 | SCREW, mach, int-teeth-lock washer, cross-recess-pan-hd, S, cd- or zn-pltd, No. 10-(0.190)-24NC x 1/2 (clip to radiator guard wiring clip brkt (1), light switch harness to rear cross member (1), foot dimmer switch to dash (1)) | 3 | ea |
| 06-11 | H2 | | H102-0145525 | 145525 | CLIP, open, wiring harness, 7/32 hole for 3/8 screw, slip on type (light switch harness to left frame side member (9), to rear cross member (2), to left tail light bracket (1), to right tail light bracket (1)) | 13 | ea |

| (1) ILLUSTRATION NO. | (2) REFER- ENCE SYMBOLS | (3) FEDERAL STOCK NO. | (4) ORDNANCE STOCK NO. | (5) MFR'S PART NO. | (6) ORDNANCE PART NO. | (7) DESCRIPTION | (8) QUANTITY INCOR- PORATED IN UNIT | (9) UNIT OF ISSUE |
|-------------------------|----------------------------------|-----------------------------|------------------------------|-----------------------|---|--|---|----------------------------|
| | | | | | | GROUP 06—ELECTRICAL SYSTEM—Continued | | |
| | | | | | | 0613.1—CHASSIS WIRING—Continued | | |
| | H2 | | H002-8328252 | | 8328252 | CLIP, roof rail wiring, type T, 0.132 dia wire to 0.032 in supporting structure (right tail light bracket (1), ignition switch circuit No. 85 to instrument panel (1)) | 2 | ea |
| | | 5935-776-2750 | G256-7762750 | | 7762750 | CONNECTOR, 3-wire (light switch harness) | 2 | ea |
| | | | | DM-4013 WO-810197 | 7524916 | CONNECTOR, assy (grounded) (M170) | 1 | ea |
| | | | | | 7726804 573004 573010 7524915 7412643 | Composed of: 1 BRACKET 1 GROMMET 1 SHELL 1 TERMINAL | | |
| | | 5935-741-2643 | G740-7412643 | WO-804782 | 7412643 | CONNECTOR, female, 2 no. 14 AWG cable terminal, assy (light switch wiring harness) | 1 | ea |
| | | | | | 572999 573000 573005 573008 572929 | Composed of: 2 BUSHING 2 CONNECTOR 2 GROMMET 1 SHELL 2 TERMINAL | | |
| | H4 | | H004-7760599 | | 7760599 | CONNECTOR, female, type PCA, 14 AWG cable, terminal, assy (light switch harness (14), fuel gage sending cable (2), voltage regulator harness (5)) | 21 | ea |
| | | | | | 572999 573000 573005 573010 572929 | Composed of: 1 BUSHING 1 CONNECTOR 1 GROMMET 1 SHELL 1 TERMINAL | | |
| | | | | WO-806415 | | CONNECTOR, male, no. 12 AWG cable, terminal, assy (voltage regulator harness) | 1 | ea |
| | | | | | 573004 573009 572930 7762642 | Composed of: 1 GROMMET 1 SHELL 1 TERMINAL | | |
| | | | G251-7762642 | WO-800425 | 7762642 | CONNECTOR, male, no. 14 AWG cable, terminal, assy (light switch wiring harness) | 4 | ea |
| | | | | | 572999 | Composed of: 1 BUSHING | | |

| | | | | | | | |
|-------|---------------|------------------------------|-------------------------------|---|---|--------|----------|
| | 5935-776-0598 | G244-7760598 | WO-800422 | 573005 573009 572929 7760598 | 1 GROMMET 1 SHELL 1 TERMINAL CONNECTOR, male, no. 14 AWG cable, terminal, assy (light switch harness (3), horn ground cable (1), voltage regulator harness (2)) | 6 | ea |
| | 5935-772-2367 | G741-7722367 | | 572999 573005 573007 572929 7722367 | Composed of: 1 BUSHING 1 GROMMET 1 SHELL 1 TERMINAL CONNECTOR, PLUG (generator to generator regulator cable) | 1 | ea |
| | 5935-776-2605 | G244-7762605 | WO-800426 | 7762605 | CONNECTOR, PLUG, double, female, no. 14 AWG cable terminal, assy (light switch wiring harness) | 2 | ea |
| | 5935-772-2368 | G741-7722368 | SCI-60-42622-2S | 572999 573002 573008 573126 572929 7722368 | Composed of: 2 BUSHING 1 GROMMET 1 SHELL 1 SLEEVE 1 TERMINAL CONNECTOR, PLUG, ELECTRICAL, wtrprf, cable connector, 1-cable (generator to generator regulator cable) | 1 | ea |
| | 5930-773-0893 | G742-7730893 | SCI-60-42622-22P WO-801250 | 7730893 | CONNECTOR, PLUG, wtrprf, elec connector, no. 12 shell, male pin insert, four no. 8 AWG cable contacts (voltage regulator harness) | 1 | ea |
| | 2920-772-0495 | G244-7720495 | SCI-60-42613-5S WO-801249 | 7720495 | CONNECTOR, PLUG, wtrprf, no. 12 shell, female socket insert, one no. 16 AWG cable contact, assy | 1 | ea |
| | 771-6895 | G244-7716895 | SCI-60-42628-51S WO-801243 | 7716895 | CONNECTOR, PLUG, wtrprf, no. 28 shell female socket insert, twelve no. 12 AWG cable contact, assy (generator regulator harness (1), light switch wiring harness (1)) | 2 | ea |
| H4 | 350-9273 | H004-0573000 | | 573000 | CONNECTOR, wtrprf cable, assy (inside) (light switch harness (16), horn ground cable (1), fuel gage sending cable (2), generator regulator harness (6)) | 25 | ea |
| H1 | | G758-8329985 H101-0594271 | WO-680460 | 8329985 594271 | COVER, auxiliary power receptacle hole SCREW, assembled washer, cross-recess-hd, S, cd- or zn-pltd, int-teeth-lock washer, 1/4"-20NC x 3/4 lg | 1 4 | ea ea |
| | | | | 145411 | FASTENER, clip (type B), S, phos-ctd, 3/8 in. cable (voltage regulator harness to dash (2), voltage regular harness to air cleaner splasher (1)) | 3 | ea |
| 06-11 | | | | 127753 | FASTENER, clip (type B), S, phos-ctd, 5/16 cable (light switch harness to fender splasher (2); voltage regulator harness to dash (2), voltage regulator harness to splash shield (1)) | 5 | ea |
| 06-11 | | | | 145540 | FASTENER, clip (type B), phos-ctd, 1/16 cable (light switch harness to fender splasher, center and rear) | 2 | ea |

06131

| (1) ILLUSTRATION NO. | (2) REFER- ENCE SYMBOLS | (3) FEDERAL STOCK NO. | (4) ORDNANCE STOCK NO. | (5) MFR'S PART NO. | (6) ORDNANCE PART NO. | (7) DESCRIPTION | (8) QUANTITY INCOR- PORATED IN UNIT | (9) UNIT OF ISSUE |
|---|----------------------------------|-----------------------------|------------------------------|------------------------------|-----------------------------|---|---|----------------------------|
| GROUP 06—ELECTRICAL SYSTEM—Continued | | | | | | | | |
| 0613.1—CHASSIS WIRING—Continued | | | | | | | | |
| | | | | | 147570 | FASTENER, clip (type B), S, 1 $\frac{1}{32}$ cable (voltage regulator harness to air cleaner splasher) | 1 | ea |
| | | | G742-7731435 | SCI-10-40822-54 WO-801251 | 7731435 | GROMMET, chassis, wiring harness to generator regulator plug nut (generator regulator harness) | 1 | ea |
| | | 5325-737-1195 | G503-7371195 | WO-347002 | 7371195 | GROMMET, RUBBER, split, 1 $\frac{1}{16}$ ID (in dash for generator regulator harness) | 1 | ea |
| | | | G592-7722333 | WO-801201 | 7722333 | GROMMET, RUBBER, wtrprf elec connector, 12-hole, 0.150 dia holes, 1.240 OD (light switch harness plug) | 1 | ea |
| | | | G740-7346945 | WO-801809 | 7346945 | GROMMET, split, ru, $\frac{3}{4}$ ID (in dash for light switch harness) | 1 | ea |
| | H4 | | H004-0573002 | | 573002 | GROMMET, waterproof cable connector, 2 No. 14 AWG cables (light switch harness) | 2 | ea |
| | H4 | | H004-0573004 | | 573004 | GROMMET, wtrprf cable connector, No. 12 AWG cable (voltage regulator harness (1), ground connector to reel lamp (1)) (M170) | 2 | ea |
| | H4 | | H004-0573005 | | 573005 | GROMMET, waterproof cable connector, No. 14 AWG cable (ru) (light switch harness (23), horn ground cable (1), fuel gage sending cable (2), voltage regulator harness (7)) | 33 | ea |
| 06-12 | | | G758-8333281 | WO-810549 | 8333281 | HARNESS, wiring, assy (generator to generator regulator) (M170) | 1 | ea |
| 06-12 | | | G758-8333282 | WO-809260 | 8333282 | HARNESS, wiring, light switch, assy (M170) | 1 | ea |
| | | | | | 7720353 | Composed of: ‡ CABLE (1.358 in.) | | |
| | | | | | 7762642 | 3 CONNECTOR | | |
| | | | | | 7760598 | 6 CONNECTOR | | |
| | | | | | 7412643 | 1 CONNECTOR | | |
| | | | | | 7760599 | 13 CONNECTOR | | |
| | | | | | 7762605 | 2 CONNECTOR | | |
| | | | | | 7716895 | 1 CONNECTOR | | |
| | | | | | 7722333 | 1 GROMMET | | |
| | | | | | 7524649 | 29 MARKER | | |
| | | | | | 7723309 | 1 NUT | | |
| | | | | | 17-T-1745 | ‡ TAPE | | |

178

179

0613.1

| | | | | | | | |
|-------|--|--------------|-----------|---------------|---|---|----|
| 06-11 | | G758-8329662 | WO-806410 | 8329662 | HARNESSES, wiring, light switch, assy (M38A1)..... | 1 | ea |
| | | | | | Composed of: | | |
| | | | | 7720853 | ‡ CABLE (1,248 in.) | | |
| | | | | 7762642 | 4 CONNECTOR | | |
| | | | | 7760598 | 3 CONNECTOR | | |
| | | | | 7412643 | 1 CONNECTOR | | |
| | | | | 7760599 | 14 CONNECTOR | | |
| | | | | 7762605 | 2 CONNECTOR | | |
| | | | | 7716895 | 1 CONNECTOR | | |
| | | | | 7722333 | 1 GROMMET | | |
| | | | | 7524649 | 27 MARKER | | |
| | | | | 7723309 | 1 NUT | | |
| | | | | 17-T-1745-60 | ‡ TAPE | | |
| 06-11 | | | WO-806417 | 8677431 | HARNESSES, wiring, voltage regulator, assy (M38A1)..... | 1 | ea |
| | | | | | Composed of: | | |
| | | | | 7722343 | 1 BUSHING | | |
| | | | | 15-C-2165-250 | ‡ CABLE (20.5 in.) | | |
| | | | | 7720853 | ‡ CABLE (306.5 in.) | | |
| | | | | 15-C-2165-200 | ‡ CABLE (61.5 in.) | | |
| | | | WO-806415 | 7760599 | 5 CONNECTOR | | |
| | | | | | 1 CONNECTOR | | |
| | | | | 7760598 | 2 CONNECTOR | | |
| | | | | 573000 | 1 CONNECTOR | | |
| | | | | 7730893 | 1 CONNECTOR | | |
| | | | | 7720495 | 1 CONNECTOR | | |
| | | | | 7731435 | 1 GROMMET | | |
| | | | | 506159 | 1 INSULATOR | | |
| | | | | A311679 | 1 MARKER | | |
| | | | | 7524649 | 9 MARKER | | |
| | | | | 7723308 | 1 NUT | | |
| | | | | 7723306 | 1 NUT | | |
| | | | | 17-T-1745-60 | ‡ TAPE | | |
| | | | | 7056715 | 1 TERMINAL | | |
| 06-12 | | | WO-810548 | | HARNESSES, wiring, voltage regulator, assy (M170)..... | 1 | ea |
| | | | | | Composed of: | | |
| | | | | 7722343 | 1 BUSHING | | |
| | | | | 15-C-2165-250 | ‡ CABLE (43.5 in.) | | |
| | | | | 15-C-2165-170 | ‡ CABLE (106.5 in.) | | |
| | | | | 15-C-2165-200 | ‡ CABLE (12.5 in.) | | |
| | | | | 7760599 | 4 CONNECTOR | | |

| (1) ILLUSTRATION NO. | (2) REFERENCE SYMBOLS | (3) FEDERAL STOCK NO. | (4) ORDNANCE STOCK NO. | (5) MFR'S PART NO. | (6) ORDNANCE PART NO. | (7) DESCRIPTION | (8) QUANTITY INCORPORATED IN UNIT | (9) UNIT OF ISSUE |
|-------------------------|--------------------------|--------------------------|---------------------------|-------------------------------|--------------------------|---|--------------------------------------|----------------------|
| | | | | | | GROUP 06—ELECTRICAL SYSTEM—Continued | | |
| | | | | | | 0613.1—CHASSIS WIRING—Continued | | |
| | | | | WO-810548 | | HARNESS—Continued | | |
| | | | | WO-806415 | | 1 CONNECTOR | | |
| | | | | | 7760598 | 1 CONNECTOR | | |
| | | | | | 7730893 | 1 CONNECTOR | | |
| | | | | | 7720495 | 1 CONNECTOR | | |
| | | | | WO-808610 | | 1 GROMMET | | |
| | | | | | 506159 | 1 INSULATOR | | |
| | | | | | A311679 | 1 MARKER | | |
| | | | | | 7524649 | 7 MARKER | | |
| | | | | | 7723308 | 1 NUT | | |
| | | | | | 7723306 | 1 NUT | | |
| | | | | | 17-T-1745-60 | ‡ TAPE | | |
| | | | | | 7056715 | 1 TERMINAL | | |
| | H4 | | H004-0506159 | | 506159 | INSULATOR, 0.395 ID, 0.030 wall thks, 1½ lg (generator regulator harness) | 1 | ea |
| | | | | WO-807196 | | LOOM, auto, asphalt finish, ⅜ ID, 74 lg (fuel gage sending cable) (M38A1) | 1 | ea |
| | | | | PM-451 | | LOOM, auto, asphalt finish, ⅜ ID, 68 lg (fuel gage cable) (M170) | 1 | ea |
| | | | G252-7524649 | WO-801692 | 7524649 | MARKER, circuit number (light switch harness (27), horn ground cable (1), fuel gage sending cable (1), voltage regulator harness (9)) | 38 | ea |
| | | | | WO-801693 | A311679 | MARKER, conduit, 0.126 thk, ¼ ID (voltage regulator harness) | 1 | ea |
| | | 772-3309 | G592-7723309 | SCI-60-37005-281 WO-801193 | 7723309 | NUT, PLAIN, KNURLED, retaining, grommet, 1.193 dia cable hole, 1⅝-18NF-2, 1.750 OD (light switch harness plug) | 1 | ea |
| | | 772-3308 | G244-7723308 | SCI-60-37005-221 WO-801192 | 7723308 | NUT, retaining, waterproof, elec connector, grommet, 0.953 dia cable hole, 1.2500-18NEF-2 thds (voltage regulator harness) | 1 | ea |
| | | 772-3306 | G244-7723306 | SCI-60-37005-131 WO-801194 | 7723306 | NUT, retaining, waterproof, elec connector, grommet, 0.328 dia cable hole, 0.625-24NEF-2 thds (voltage regulator harness) | 1 | ea |

| | | | | | | | |
|----|---------------|--------------|-----------------------|--------------|---|----|------|
| H1 | | H101-0454782 | | 454782 | SCREW, int-teeth lock washer, cross-recess, pan-hd, header-pt, S, cd- or zn-pltd, no. 10-24NC x 5/8 (generator to volt regulator cable and volt regulator harness to dash) | 4 | ea |
| H4 | 350-9279 | H004-0573007 | | 573007 | SHELL, wtrprf cable connector, 1-cable, female (mates w/SHELL 573010) (2 wire) (light switch harness (3), horn ground cable (1), voltage regulator harness (2)) | 6 | ea |
| H4 | 350-9282 | H004-0573010 | | 573010 | SHELL, wtrprf cable connector, 1 cable, male (mates w/SHELL 573007) (2-wire) (light switch harness (14), fuel gage sending cable (2), voltage regulator harness (5)) | 21 | ea |
| H4 | 350-9280 | H004-0573008 | | 573008 | SHELL, wtrprf connector, 2 cable, female (mates w/SHELL 573009) (light switch cable harness) | 3 | ea |
| H4 | | H004-0573009 | | 573009 | SHELL, wtrprf connector, 1 cable, male (mates w/SHELL 573008) (light switch harness (4), voltage regulator harness (1)) | 5 | ea |
| H4 | | G251-7762751 | | 7762751 | SLEEVE, connector cover (light switch harness) | 2 | ea |
| | | H004-0573126 | | 573126 | SLEEVE, w/CONNECTOR, 3 wire, 14 ga, assy (light switch harness) | 2 | ea |
| H5 | | | | 7762750 | Composed of: | | |
| | | | | 7762751 | 1 CONNECTOR | | |
| | | | | 7762687 | 1 SLEEVE | | |
| H4 | | G256-7762687 | | 7762687 | 3 SPRING | | |
| | | H005-0875945 | | 17-T-1745-60 | SPRING, sleeve and connector (light switch harness) | 6 | ea |
| H4 | 350-9269 | H004-0572930 | | 572930 | TAPE, insulating, vinyl chloride acetate, black, width 3/4 in., thnks 0.010 in. (108 ft per roll) | 1 | roll |
| H4 | | H004-0572929 | | 572929 | TERMINAL, cable, snap male, type V, 15 amp, no. 12 AWG cable | 1 | ea |
| H4 | 705-6715 | | DM-54963 WO-810198 | 7524915 | TERMINAL, cable, snap, type 1, 15 amp, no. 14 AWG cable (light switch harness (25), horn ground cable (1), fuel gage sending cable (2), voltage regulator harness (7)) | 35 | ea |
| | | | | 7056715 | TERMINAL, connector (ground connector to reel lamp) (M170) | 1 | ea |
| | | | | 7056708 | TERMINAL, straight (generator regulator harness) | 1 | ea |
| H4 | | H004-7056708 | | 7056708 | TERMINAL, waterseal, solderless, cop, no. 12 and 14 AWG cable, 1 1/4 lg, hole for no. 10 screw (horn to ground cable) | 1 | ea |
| | 6140-361-7944 | G503-7371311 | WO-A1098 | 7371311 | 0615-RADIO SUPPRESSION LEAD, elec, eng, gr, 1 5/16 wide, 7 1/2 lg, 2 holes (used up to vehicle serial no. 83475) (generator insulator bolt to engine mtg bracket) | 1 | ea |

| (1) ILLUSTRATION NO. | (2) REFERENCE SYMBOLS | (3) FEDERAL STOCK NO. | (4) ORDNANCE STOCK NO. | (5) MFR'S PART NO. | (6) ORDNANCE PART NO. | (7) DESCRIPTION | (8) QUANTITY INCORPORATED IN UNIT | (9) UNIT OF ISSUE |
|---|--------------------------|--------------------------|---------------------------|------------------------------|--------------------------|--|--------------------------------------|----------------------|
| GROUP 06—ELECTRICAL SYSTEM—Continued | | | | | | | | |
| 0615—RADIO SUPPRESSION—Continued | | | | | | | | |
| | | | | WO-809624 | | LEAD, elec, engine, gr, $1\frac{5}{16}$ wide, $12\frac{3}{4}$ lg, 3 holes (use after vehicle serial No. 83475) | 1 | ea |
| | H1 | 012-0369 | H001-4167601 | | 120369 | NUT, plain, hex, lt, s-fin, S, cd- or zn-pltd, $\frac{3}{8}$ -24NF-2 | 1 | ea |
| | H1 | 012-0647 | H001-5421261 | | 120647 | SCREW, mach, hex-hd, S, cd- or zn-pltd, $\frac{3}{8}$ -24NF-3 x 1 | 1 | ea |
| | H1 | 5310-017-8551 | H001-7124741 | | 178551 | WASHER, lock, int-ext-teeth, S, cd- or zn-pltd, $\frac{3}{8}$ x 0.985 OD | 2 | ea |
| | H1 | 5310-017-8532 | H001-7124911 | | 178532 | WASHER, lock, int-ext-teeth, S, cd- or zn-pltd, style No. 7, 0.85 OD, $\frac{3}{16}$ bolt size | 2 | ea |
| 0617—TRAILER COUPLING | | | | | | | | |
| | | 5935-735-5938 | G747-7355938 | SCI-L8719-32 WO-807154 | 7355938 | BRACKET, polarizing, elec connector (used on vehicles through serial No. 75226) | 1 | ea |
| | H4 | 5975-350-9272 | H004-0572999 | | 572999 | BUSHING, terminal grommet adapting, wtrprf cable connector | 7 | ea |
| | H5 | 6145-772-0853 | H005-0812364 | | 812364 | CABLE, automotive, low tension ins (plastic natural or syn-ru) wtrprf, sgle cond (receptacle) (8 in.) | † | ft |
| | | 5935-776-2750 | G256-7762750 | | 7762750 | CONNECTOR, 3 in. wire | 1 | ea |
| | | 5935-776-0598 | G244-7760598 | WO-800422 | 7760598 | CONNECTOR, male, No. 14 AWG (receptacle and cable) | 4 | ea |
| | | | | | 572999 | Composed of: | | |
| | | | | | 573005 | 1 BUSHING | | |
| | | | | | 573007 | 1 GROMMET | | |
| | | | | | 572929 | 1 SHELL | | |
| | | | | | 572929 | 1 TERMINAL | | |
| 18-4 | | 5935-773-1428 | G592-7731428 | SCI-60-36397-28 WO-800391 | 7731428 | COVER, receptacle, assy | 1 | ea |
| | H1 | 044-6609 | H101-0446609 | | 446609 | BOLT, integral, lock washer, sltd-hex-hd, S, cd- or zn-pltd, $\frac{1}{4}$ -20NC-2A x $\frac{5}{8}$ | 4 | ea |
| | H4 | 5325-350-9277 | H004-0573005 | | 573005 | GROMMET, connector, No. 14 AWG cable, 0.160 dia wire (receptacle and cable) | 4 | ea |
| | H4 | 5325-350-9275 | H004-0573002 | | 573002 | GROMMET, connector, 2 No. 14 AWG cable, 0.160 dia wire (receptacle and cable) | 1 | ea |
| | | | G592-7722333 | SCI-10-40828-51 WO-801201 | 7722333 | GROMMET, RUBBER, connector, 12 hole, 0.150 dia hole, 1.240 OD (receptacle, w/CABLE) | 1 | ea |
| | | 2530-752-4649 | G252-7524649 | WO-801692 | 7524649 | MARKER, circuit number | 7 | ea |

| | | | | | | | |
|----|---------------|--------------|-------------------------------|---------|--|---|----|
| | 5310-772-3309 | G592-7723309 | SCI-60-37005-281 WO-801193 | 7723309 | NUT, PLAIN KNURLED, retaining, elec connector grommet, 1.193 dia cable hole, 1 $\frac{5}{8}$ -18NEF-2, 1.750 OD | 1 | ea |
| | | G740-7731429 | SCI-60-36028-51S WO-800392 | 7731429 | RECEPTACLE, assy (superseded by RECEPTACLE 8376209) (M38A1) | 1 | ea |
| | | G258-8376209 | SCI-60-36030-51S WO-811867 | 8376209 | RECEPTACLE, assy (supersedes RECEPTACLE 7731429) (M38A1) | 1 | ea |
| | | | PC-5292276 WO-801531 | 8673318 | RECEPTACLE, w/CABLE, assy (superseded by RECEPTACLE WO-811900) (M38A1) | 1 | ea |
| | | | | 812364 | Composed of: | | |
| | | | | 7760598 | 1 CABLE (49 in.) | | |
| | | | | 7722333 | 4 CONNECTOR | | |
| | | | | 7524649 | 1 GROMMET | | |
| | | | | 7723309 | 7 MARKER | | |
| | | | | 7731429 | 1 NUT | | |
| | | | | 7056708 | 1 RECEPTACLE | | |
| | | | WO-811900 | | 1 TERMINAL | | |
| | | | | | RECEPTACLE, w/CABLE, assy (supersedes RECEPTACLE 8673318) (M38A1) | 1 | ea |
| | | | | 812364 | Composed of: | | |
| | | | | 7760598 | 1 CABLE (49.75 in.) | | |
| | | | | 7722333 | 4 CONNECTOR | | |
| | | | | 7524649 | 1 GROMMET | | |
| | | | | 7723309 | 7 MARKER | | |
| | | | | 7731429 | 1 NUT | | |
| | | | | 7056708 | 1 RECEPTACLE | | |
| | | | | 120361 | 1 TERMINAL | | |
| H1 | 012-0361 | H001-4135661 | | 454782 | NUT, plain, hex, S, cd- or zn-pltd, No. 10-24NC-2 | 1 | ea |
| H1 | | H101-0454782 | | | SCREW, mach, w/int-teeth-lock washer, pan-hd, cross-recess, S, cd- or zn-pltd, header-pt, No. 10-24NC x $\frac{5}{8}$ | 1 | ea |
| H1 | 017-8378 | H001-7124621 | | 178378 | WASHER, lock, int-ext-teeth, S, cd- or zn-pltd, No. 10 x 0.610 | 1 | ea |
| H4 | 350-9279 | H004-0573007 | | 573007 | SHELL, female connector, 1 cable (2-wire) (mates w/SHELL 573010) | 4 | ea |
| H4 | 350-9280 | H004-0573008 | | 573008 | SHELL, female connector, 2 cable (mates w/SHELL 573009) | 1 | ea |
| H4 | 5935-350-9281 | H004-0573009 | | 573009 | SHELL, male connector (mates w/SHELL 573008) | 1 | ea |
| | 2510-776-2751 | G256-7762751 | | 7762751 | SLEEVE, 3 in wire (connector) | 1 | ea |
| | 2510-776-2687 | G256-7762687 | | 7762687 | SPRING, connector socket | 1 | ea |
| H4 | | H004-0572929 | | 572929 | TERMINAL, cable, snap, male, type 1, 15 amp, no. 14 AWG cable | 7 | ea |
| H4 | | H004-7056708 | | 7056708 | TERMINAL, solderless, cop, no. 12 and 14 AWG cable, 1 $\frac{1}{4}$ lg, hole for no. 10 screw (inter-vehicle receptacle) | 1 | ea |

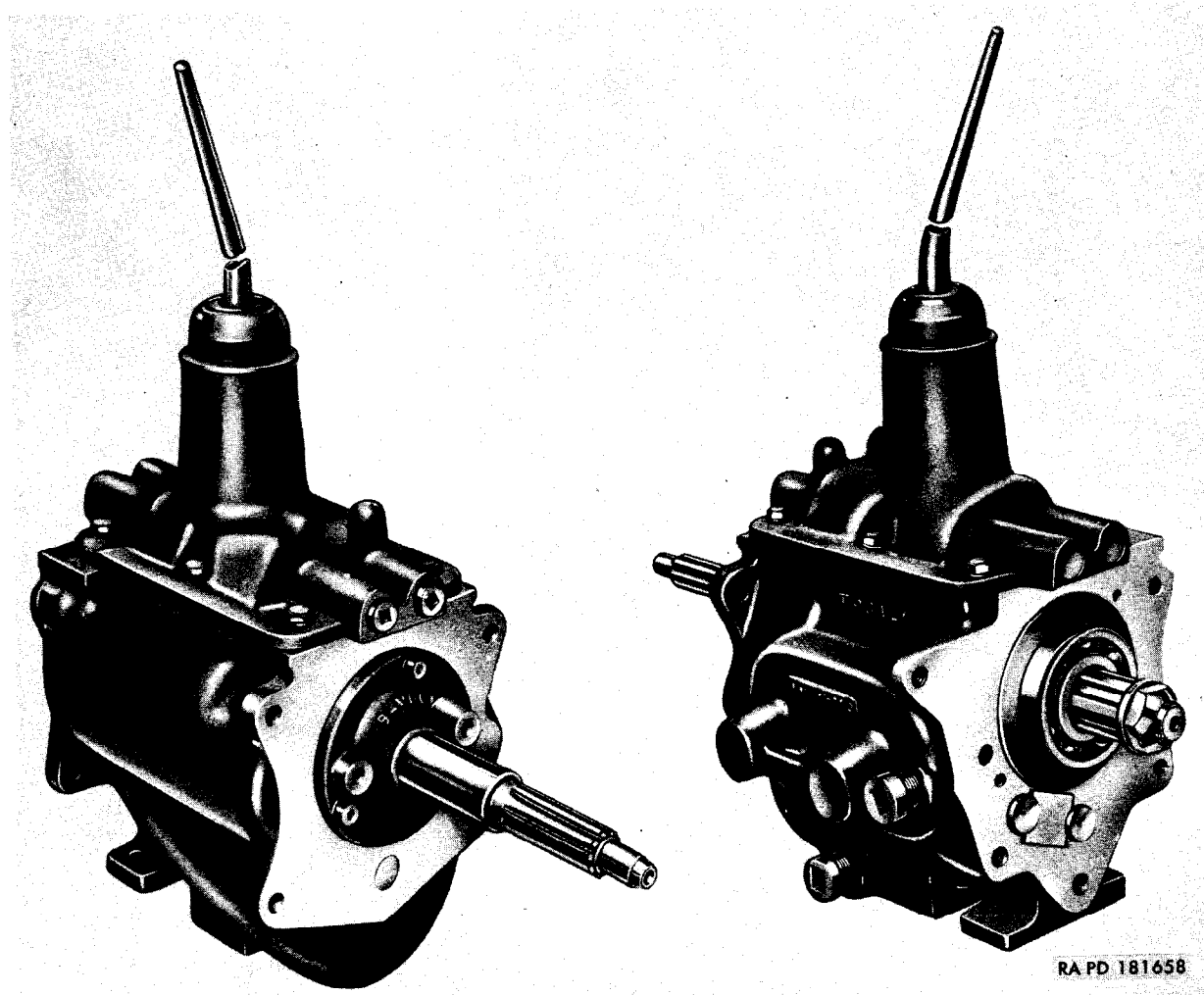

RA PD 181658

Figure 07-1. Transmission, assy (7697471)

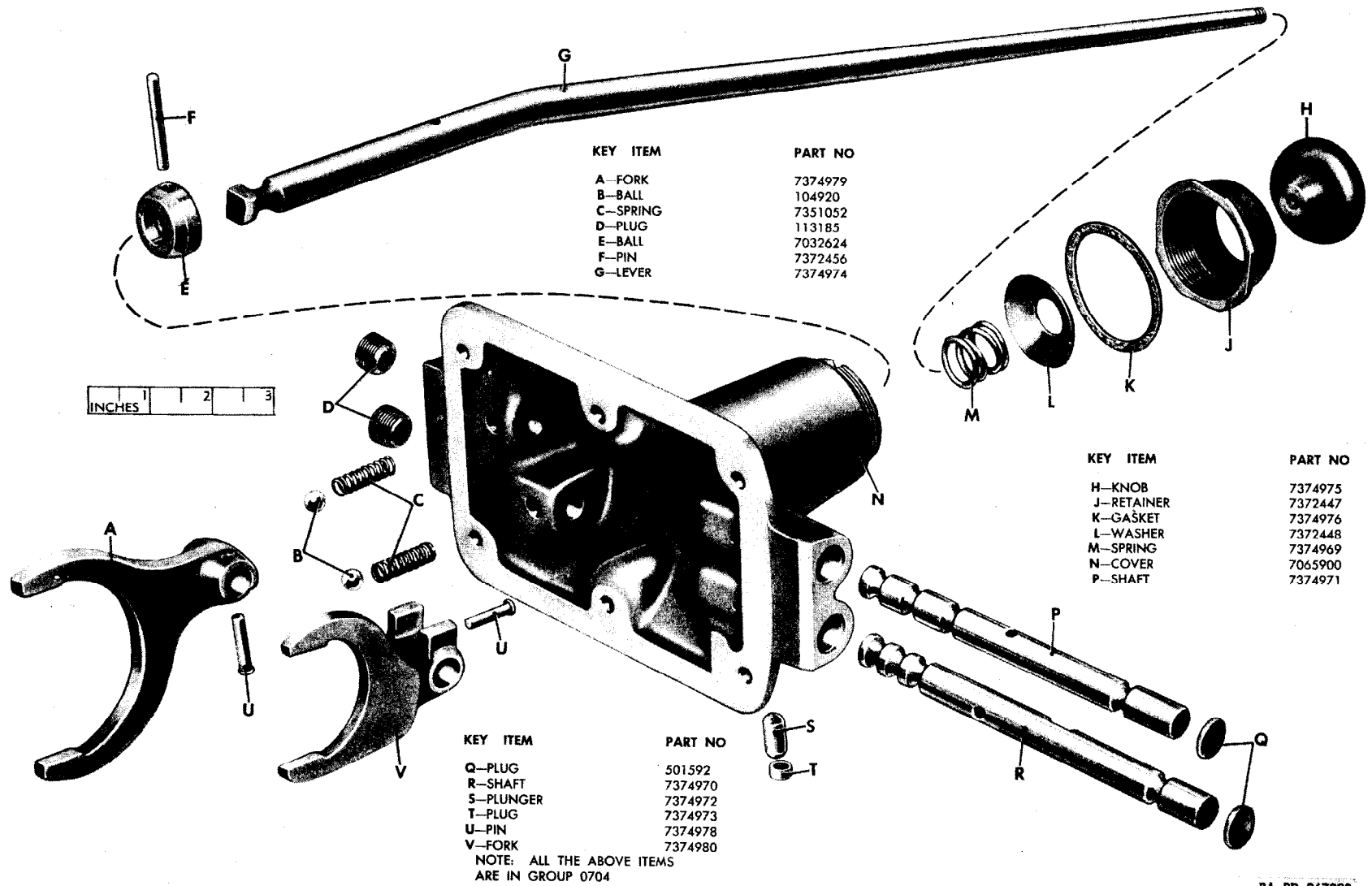

Figure 07-2. Transmission cover and related parts—exploded view

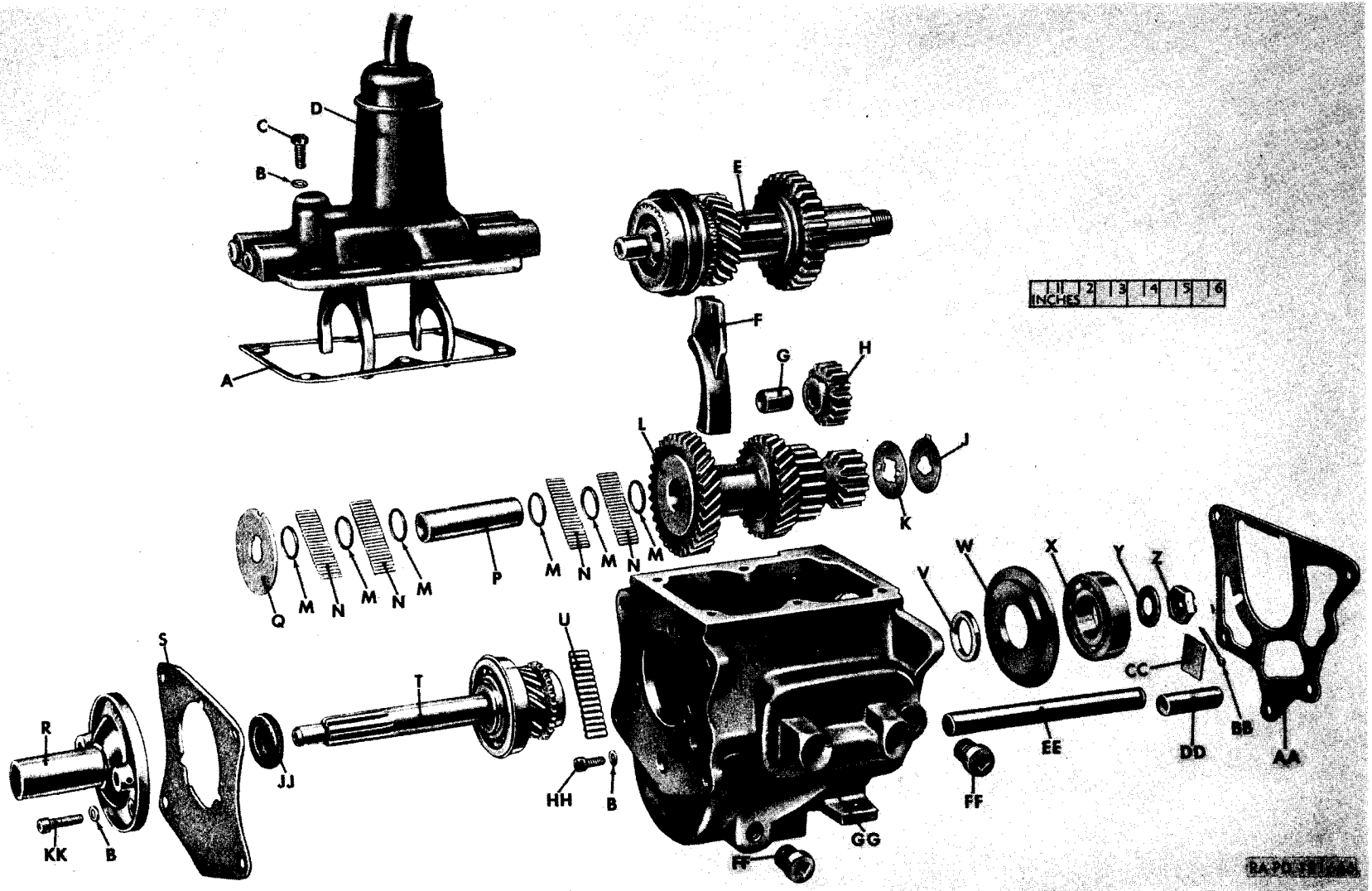

Figure 07-3. Transmission gears and related parts—exploded view

| <i>Key</i> | <i>Item</i> | <i>Part No.</i> | <i>Group</i> | <i>Key</i> | <i>Item</i> | <i>Part No.</i> | <i>Group</i> |
|------------|-------------------|-----------------|--------------|------------|--------------------|-----------------|--------------|
| A | -GASKET..... | 7374977 | 0704 | S | -GASKET..... | 8329853 | 0701 |
| | | | {0702.1 | T | -SHAFT, ASSY..... | 8673949 | 0702.1 |
| B | -GASKET..... | 8329873 | {0702.5 | U | -ROLLER..... | 712420 | 0702.3 |
| | | | {0704 | V | -SPACER..... | 7374992 | 0702.3 |
| C | -SCREW..... | 120229 | 0704 | W | -ADAPTER..... | 7374991 | 0702.3 |
| D | -COVER, ASSY..... | 7032623 | 0704 | X | -BEARING..... | 700336 | 0702.3 |
| E | -SHAFT, ASSY..... | WG-AT90A2 | 0702.3 | Y | -WASHER..... | 7375131 | 0802.1 |
| F | -COLLECTOR..... | 7697420 | 0702.5 | Z | -NUT..... | 7743652 | 0802.1 |
| G | -BEARING..... | 7697419 | 0702.5 | AA | -GASKET..... | 7372878 | 0800 |
| H | -GEAR..... | 8331730 | 0702.5 | BB | -PIN..... | 120123 | 0802.1 |
| J | -WASHER..... | 7697547 | 0702.5 | CC | -PLATE..... | 7697424 | 0702.5 |
| K | -WASHER..... | 7697429 | 0702.5 | DD | -SHAFT..... | 7697425 | 0702.5 |
| L | -GEAR..... | 7697422 | 0702.5 | EE | -COUNTERSHAFT..... | 7697421 | 0702.5 |
| M | -WASHER..... | 7697427 | 0702.5 | FF | -PLUG..... | 7372879 | 0701 |
| N | -ROLLER..... | 712386 | 0702.5 | GG | -CASE..... | 7372877 | 0701 |
| P | -SPACER..... | 7372667 | 0702.5 | HH | -BOLT..... | 571283 | 0702.5 |
| Q | -WASHER..... | 7697428 | 0702.5 | JJ | -SEAL, OIL..... | 7697572 | 0702.1 |
| R | -COVER..... | 7697564 | 0702.1 | KK | -SCREW..... | 426892 | 0702.1 |

Figure 07-3. Transmission gears and related parts—exploded view—legend

| KEY ITEM | PART NO. |
|-----------|----------|
| A—RING | 8376244 |
| B—SLEEVE | 8376245 |
| C—RING | 7374996 |
| D—SPRING | 8376246 |
| E—HUB | 8331733 |
| F—PLATE | 7350113 |
| G—BEARING | 7374993 |
| H—GEAR | 7994786 |
| J—SHAFT | 7374998 |
| K—GEAR | 7374995 |

NOTE: ALL ITEMS LISTED
ARE IN GROUP 0702.3

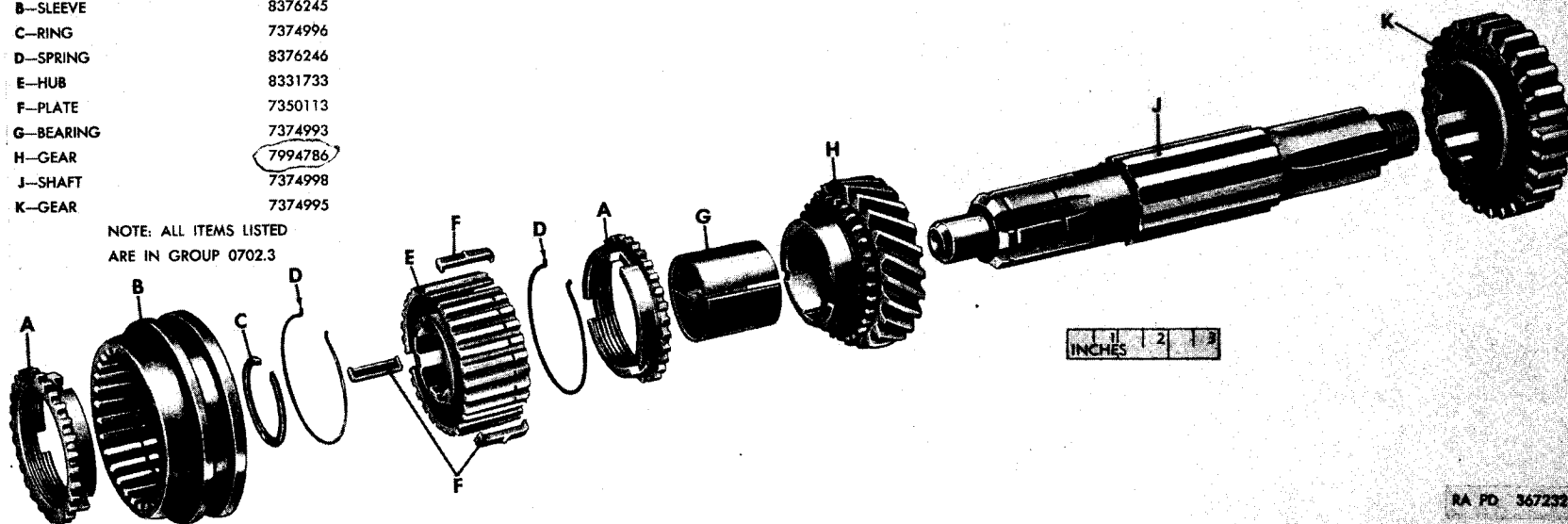
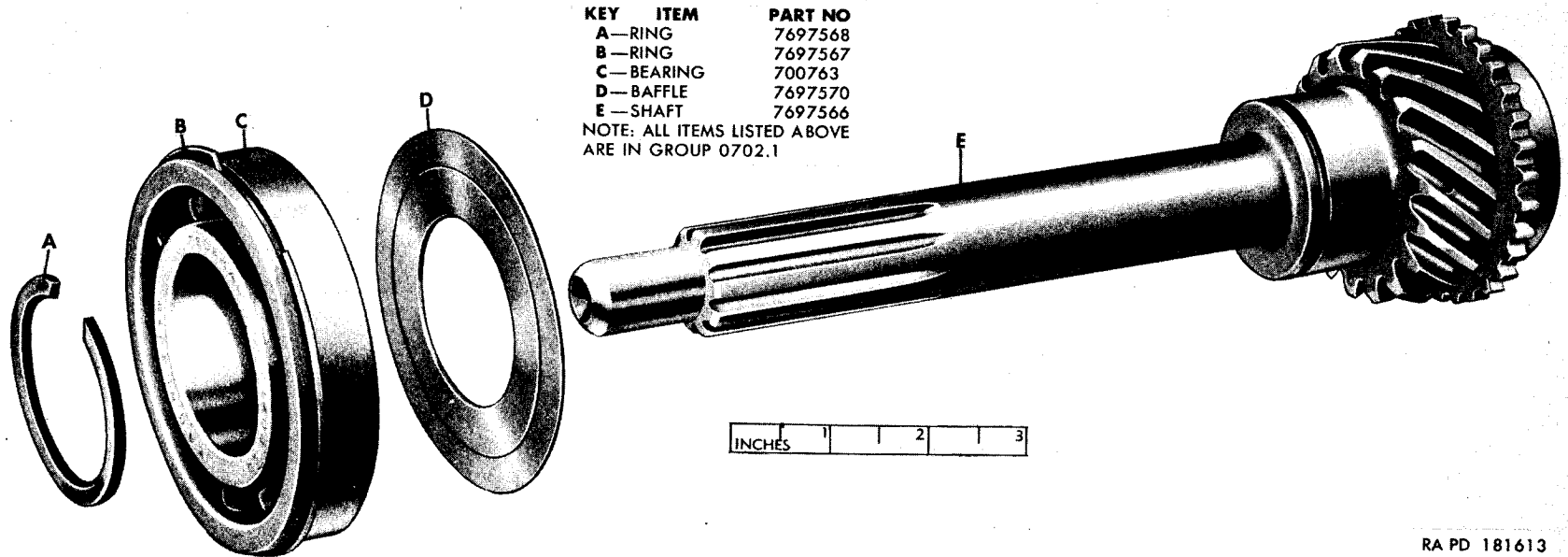

Figure 07-4. Transmission main shaft, assy—exploded view



RA PD 181613

Figure 07-5. Transmission main drive gear, assy—exploded view

| (1) ILLUSTRATION NO. | (2) REFER- ENCE SYMBOLS | (3) FEDERAL STOCK NO. | (4) ORDNANCE STOCK NO. | (5) MFR'S PART NO. | (6) ORDNANCE PART NO. | (7) DESCRIPTION | (8) QUANTITY INCOR- PORATED IN UNIT | (9) UNIT OF ISSUE |
|--|----------------------------------|-----------------------------|------------------------------|---------------------------|-----------------------------|---|---|----------------------------|
| GROUP 07—TRANSMISSION | | | | | | | | |
| 0700—TRANSMISSION ASSEMBLY | | | | | | | | |
| 07-1 | | 2520-769-7471 | G740-7697471 | WG-AS3T90C WO-800079 | 7697471 | TRANSMISSION, assy..... | 1 | ea |
| | H1 | 5305-012-2267 | H001-5421961 | | 122267 | SCREW, cap, hex-hd, S, cd- or zn-pltd, 7/16-14NC-3 x 1 1/4 | 4 | ea |
| | H1 | 5310-011-6104 | H001-1525020 | | 116104 | WASHER, flat, copper, 1 5/32 ID, 5/8 OD, 0.065 thk (used on vehicles through serial no. 56020) | 4 | ea |
| | | | G758-8332514 | WO-809706 | 8332514 | WASHER, LOCK, ext-teeth, S, cd- or zn-pltd, 7/16 in. (shakeproof) (used on vehicles after serial no. 56020) | 4 | ea |
| | H1 | 5310-012-0383 | H001-7025711 | | 120383 | WASHER, lock, med, S, cd- or zn-pltd, 7/16 in..... | 4 | ea |
| 0701—CASE | | | | | | | | |
| 07-3 | | 2520-737-2877 | G740-7372877 | WG-T90C1 WO-642754 | 7372877 | CASE, assy..... | 1 | ea |
| 07-3 | | | G758-8329853 | WO-640351 | 8329853 | GASKET, case..... | 1 | ea |
| 07-3 | | 4730-737-2879 | G740-7372879 | WG-4646A WO-801660 | 7372879 | PLUG, sq, pipe, ck-hd, MI, 1/2 in. (transmission filling (1) and drain opening (1)) | 2 | ea |
| 0702.1—INPUT SHAFT, BEARINGS, AND RETAINERS | | | | | | | | |
| 07-5 | | 2520-769-7570 | G740-7697570 | WG-T90A136A WO-640893 | 7697570 | BAFFLE, oil..... | 1 | ea |
| 07-5 | H12 | | H012-1330040 | | 700763 | BEARING, ball, MIL-STD-CODE-112-04002-0500 (rad, SR, lt, loading groove, snap ring, 1.5748 bore, 3.1496 OD, 0.7087 width) | 1 | ea |
| 07-3 | | 2520-769-7564 | G740-7697564 | WG-T90A6 WO-640422 | 7697564 | COVER, main drive gear bearing..... | 1 | ea |
| 07-3 | H1 | 042-6892 | H101-0426892 | | 426892 | SCREW, cap, socket-hd, alloy-S, cd- or zn-pltd, 5/16- 18NC-3 x 1 | 3 | ea |
| 07-3 | | | G503-0194032 | WG-X1552 WO-51875 | 8329873 | GASKET, 5/16 ID, 1/2 OD, 3/32 thk (bearing retainer bolt)... | 3 | ea |
| 07-5 | | | G740-7697567 | WG-T90A6-1/2 WO-640782 | 7697567 | RING, RETAINING, snap, bearing, 0.0625 thk..... | 1 | ea |
| 07-5 | | | G740-7697568 | WG-4559A WO-640783 | 7697568 | RING, RETAINING, snap, bearing, 0.086-0.088 thk..... | † | ea |
| | | | G176-5276883 | WG-4559B WO-640784 | 5276883 | RING, RETAINING, snap, bearing, 0.089-0.091 thk..... | † | ea |

| | | | | | | | | |
|---|-----|---------------|--------------|--------------------------|--------------------|--|----|----|
| | | | G740-7697569 | WG-4559C WO-640785 | 7697569 | RING, RETAINING, snap, bearing, 0.092-0.094 thk..... | ‡ | ea |
| | | 5340-769-7571 | G740-7697571 | WG-4559D WO-640894 | 7697571 | RING, RETAINING, snap, bearing, 0.096-0.098 thk..... | ‡ | ea |
| | | | | WG-4559E WO-808858 | | RING, RETAINING, snap, bearing, 0.100-0.102 thk..... | ‡ | ea |
| 07-3 | | 5330-769-7572 | G740-7697572 | WG-T90A54A WO-645980 | 7697572 | SEAL, oil, main drive gear bearing retainer..... | 1 | ea |
| 07-5 | | 2520-769-7566 | G740-7697566 | WG-T90A16 WO-640428 | 7697566 | SHAFT, input, w/integral GEAR..... | 1 | ea |
| 07-3, 5 | | | | WG-AT90A16 WO-640427 | 8673949 | SHAFT, input, w/integral GEAR and BEARINGS, assy..... | 1 | ea |
| 0702.3—MAIN SHAFT, GEARS, BEARINGS, AND SYNCHRONIZER | | | | | | | | |
| 07-3 | | 2520-737-4991 | G740-7374991 | WG-T90A7B WO-644552 | 7374991 | ADAPTER, main shaft bearing..... | 1 | ea |
| 07-3 | H12 | | H012-1304035 | | 700336 | BEARING, ball, MIL-STD-CODE 111-03503-0000 (rad, SR, med, non-loading groove, 1.3780 bore, 3.1496 OD, 0.8268 width) (main shaft rear) | 1 | ea |
| 07-4 | | 3120-737-4993 | G740-7374993 | WG-T88-19E WO-640400 | 7374993 | BEARING, bushing type, bz, 1.493 ID, 1.4990 OD, 1.422 width (main shaft second speed gear) | 1 | ea |
| 07-4 | | 2520-737-4994 | G740-7374994 | WG-AT90A11 WO-640398 | 7994786 7374994 | GEAR, second speed (22T, 2.970 OD)..... | 1 | ea |
| 07-4 | | 2520-737-4995 | G740-7374995 | WG-T90A12 WO-640401 | 7374995 | GEAR, SPUR, S, 1.645 ID, 10 splines, 29T, 3.825 OD, sliding, low and reverse | 1 | ea |
| 07-4 | | 2530-833-1733 | G179-8331733 | WG-T90AZ½ | 8331733 | HUB, second and high speed synchronizer..... | 1 | ea |
| 07-4 | | | G502-7350113 | WG-T88-13H CC-856470 | 7350113 | PLATE, shifting, second and high speed synchronizer..... | 3 | ea |
| 07-4 | | | G740-8376244 | WG-T88-14F WO-640397 | 8376244 | RING, blocking, second and high speed synchronizer..... | 2 | ea |
| 07-4 | | | G740-7374996 | WG-4653 WO-640431 | 7374996 | RING, snap, second and high speed synchronizer hub (1 ⁵ / ₆₄ ID) | 1 | ea |
| 07-3 | H12 | | H012-0712420 | | 712420 | ROLLER, needle bearing, MIL-STD-CODE 999-59168- 0000 (spherical ends, 0.2188 dia, 0.7500 lg) (main shaft pilot bearing) (in main drive gear) | 14 | ea |
| 07-4 | | 2520-737-4998 | G740-7374998 | WG-T90A2 WO-640390 | 7374998 | SHAFT, main..... | 1 | ea |
| 07-3, 4 | | | | WG-AT90A2 WO-640389 | | SHAFT, main, w/GEARS and blocking RING, assy..... | 1 | ea |
| 07-4 | | 2520-837-6245 | G505-8376245 | WG-T88-15C CC-856464 | 8376245 | SLEEVE, second and high speed synchronizer..... | 1 | ea |
| 07-3 | | 2520-737-4992 | G740-7374992 | WG-T90A137A WO-643621 | 7374992 | SPACER, main shaft bearing..... | 1 | ea |

| (1) ILLUSTRATION NO. | (2) REFERENCE SYMBOLS | (3) FEDERAL STOCK NO. | (4) ORDNANCE STOCK NO. | (5) MFR'S PART NO. | (6) ORDNANCE PART NO. | (7) DESCRIPTION | (8) QUANTITY INCORPORATED IN UNIT | (9) UNIT OF ISSUE |
|---|--------------------------|--------------------------|---------------------------|------------------------------------|--------------------------|---|--------------------------------------|----------------------|
| GROUP 07—TRANSMISSION—Continued | | | | | | | | |
| 0702.3—MAIN SHAFT, GEARS, BEARINGS, AND SYNCHRONIZER—Continued | | | | | | | | |
| 07-4 | | | G505-8376246 | WG-4682J CC-856471 WO-640394 | 8376246 | SPRING, synchronizer..... | 2 | ea |
| | | 2520-833-1732 | G179-8331732 | WG-AT90A2-1/2 WO-640392 | 8331732 | SYNCHRONIZER ASSEMBLY, second and high speed, w/o blocking RING | 1 | ea |
| | | 2520-737-4999 | G740-7374999 | WG-IAT90A2-1/2 WO-640391 | 7374999 | SYNCHRONIZER, second and high speed, w/blocking RING, assy | 1 | ea |
| 0702.5—COUNTERSHAFT, IDLER SHAFT, GEARS, AND SPACER | | | | | | | | |
| 07-3 | | 3120-769-7419 | G740-7697419 | WG-T86-85 WO-640419 | 7697419 | BEARING, bushing type, bz, 0.743 ID, 0.887 OD, 1 1/16 width (idler gear) | 1 | ea |
| 07-3 | | 2520-769-7420 | G740-7697420 | WG-AT90A140 WO-640413 | 7697420 | COLLECTOR, oil, countershaft gear..... | 1 | ea |
| 07-3 | H1 | 057-1288 | H101-0571288 | | 571288 | BOLT, cap, socket-hd, alloy-S, phos-ctd, 5/16-24NF-3 x 3/4 | 2 | ea |
| 07-3 | | 2520-769-7421 | G740-7697421 | WG-T90A43 WO-640412 | 7697421 | COUNTERSHAFT..... | 1 | ea |
| 07-3 | | | G503-0194032 | WG-X1552 WO-51875 | 8329873 | GASKET, 5/16 ID, 1/2 OD, 3/32 thk (oil collector)..... | 2 | ea |
| 07-3 | | 2520-769-7422 | G740-7697422 | WG-T90A8 WO-640405 | 7697422 | GEAR, cluster countershaft, 1.0625 ID, 4.0673 OD, 14T, 19T, 26T, 33T | 1 | ea |
| 07-3 | | 2520-833-1730 | G179-8331730 | WG-T90A10 | 8331730 | GEAR, reverse idler (S, 0.887 ID, 2.220 OD, 16T, 1 1/4 over-all lg) | 1 | ea |
| | | 2520-769-7423 | G740-7697423 | WG-AT90A10 WO-640417 | 7697423 | GEAR, reverse idler, w/BEARING, assy..... | 1 | ea |
| 07-3 | | 2520-769-7424 | G740-7697424 | WG-T90A48A WO-644316 | 7697424 | PLATE, lock, idler shaft and countershaft..... | 1 | ea |
| 07-3 | H12 | | H012-0712386 | | 712386 | ROLLER, needle, bearing, MIL-STD-CODE 999-59004-0000 (spherical ends, 0.1250 dia, 0.750 lg) (countershaft gear bearing) | 88 | ea |
| 07-3 | | 2520-769-7425 | G740-7697425 | WG-T90A35 WO-640420 | 7697425 | SHAFT, reverse idler gear..... | 1 | ea |
| 07-3 | | 2520-737-2667 | G740-7372667 | WG-T90A28A WO-802414 | 7372667 | SPACER, countershaft bearing..... | 1 | ea |

| | | | | | | | | | |
|--|----|---------------|--------------|--------------------------|---------|--|---|----|--|
| 07-3 | | 5310-769-7428 | G740-7697428 | WG-T90A30 WO-640409 | 7697428 | WASHER, bz, $\frac{3}{4}$ ID, $2\frac{1}{2}$ OD, 0.0625 thk (thrust countershaft, front) | 1 | ea | |
| 07-3 | | 5310-769-7427 | G740-7697427 | WG-T86D29 WO-640778 | 7697427 | WASHER, S, 0.765 ID, 0.962 OD, 0.050 thk (countershaft bearing) | 6 | ea | |
| | | 3120-769-7546 | G740-7697546 | WG-T90A33A WO-640779 | 7697546 | WASHER, thrust, countershaft, rear, S, 0.0555 thk | † | ea | |
| 07-3 | | 3120-769-7547 | G740-7697547 | WG-T90A33 WO-640411 | 7697547 | WASHER, thrust, countershaft, rear, S, 0.0625 thk | † | ea | |
| 07-3 | | 3120-769-7429 | G740-7697429 | WG-T90A32 WO-640410 | 7697429 | WASHER, thrust, S, backed bronze, 0.0265 thk, countershaft, rear | 1 | ea | |
| 0704—GEAR SHIFT, LEVER, SHAFTS, AND FORKS | | | | | | | | | |
| 07-2 | H2 | | H002-0100140 | | 104920 | BALL, alloy-S, grade 2, $\frac{3}{8}$ in. (poppet, gear shifter shaft) | 2 | ea | |
| 07-2 | | 2520-703-2624 | G740-7032624 | WO-802579 | 7032624 | BALL, fulcrum, gear shift lever | 1 | ea | |
| 07-2 | | | G740-7065900 | WG-T90C148B WO-801730 | 7065900 | BOOT, gear shift lever (listed in subgroup 1805) | 1 | ea | |
| | | | G758-8329994 | WG-20366S WO-635868 | 8329994 | COVER, gear shift lever | 1 | ea | |
| 07-3 | H1 | | H001-5419161 | | 120229 | SCREW, hex-hd, $\frac{5}{16}$ -18NC x $\frac{7}{8}$ (superseded by SCREW 120229) | 6 | ea | |
| 07-3 | | 2520-703-2623 | G740-7032623 | WO-802612 | 7032623 | SCREW, cap, hex-hd, S, cd- or zn-pltd, $\frac{5}{16}$ -18NC-3 x $\frac{7}{8}$ (supersedes SCREW 8329994) | 6 | ea | |
| 07-2 | | 2520-737-4980 | G740-7374980 | WG-T90C24 WO-642767 | 7374980 | COVER, transmission control lever, assy | 1 | ea | |
| 07-2 | | 2520-737-4979 | G740-7374979 | WG-T90-23 WO-642766 | 7374979 | FORK, shifter, low and reverse speed | 1 | ea | |
| 07-2 | | 5315-737-4978 | G740-7374978 | WG-4583 WO-642768 | 7374978 | FORK, shifter, second and high speed | 1 | ea | |
| 07-3 | | | G503-0194032 | WG-X1552 WO-51875 | 8329873 | PIN, S, 0.188 dia, 0.9375 lg under-hd, 0.250 hd dia | 2 | ea | |
| 07-3 | | 2520-737-4977 | G740-7374977 | WG-T90C115 WO-642770 | 7374977 | GASKET, $\frac{1}{8}$ ID, $\frac{1}{2}$ OD, $\frac{3}{32}$ thk (control housing bolt) | 6 | ea | |
| 07-2 | | 2520-737-4976 | G740-7374976 | WG-4648 WO-801733 | 7374976 | GASKET, gear shift lever housing | 1 | ea | |
| 07-2 | | 5980-737-4975 | G740-7374975 | WO-644233 | 7374975 | GASKET, gear shift lever housing cap | 1 | ea | |
| 07-2 | | 2520-737-4974 | G740-7374974 | WG-AC90C2C WO-801731 | 7374974 | KNOB, gear shift lever | 1 | ea | |
| 07-2 | | 5315-360-8153 | G503-7372456 | WG-C84B12A WO-A1382 | 7372456 | LEVER, gear shift, w/BALL and PIN, assy | 1 | ea | |
| 07-2 | H6 | | H006-0282435 | | 501592 | PIN, STRAIGHT, HEADLESS, gear shift lever fulcrum ball | 1 | ea | |
| 07-2 | H6 | 011-3185 | H006-0283755 | | 113185 | PLUG, expansion, S, $1\frac{1}{8}$ in. dia (shift rail hole) | 2 | ea | |
| 07-2 | | 2520-499-8876 | G740-7374973 | WG-4572D WO-642759 | 7374973 | PLUG, pipe, sq-socket, hdls, MI, $\frac{3}{8}$ in. (shift rail hole) | 2 | ea | |
| 07-2 | | 2520-737-4972 | G740-7374972 | WG-T90-86 WO-642758 | 7374972 | PLUG, taper, $\frac{3}{8}$ in (interlock plunger hole) | 1 | ea | |
| | | | | | | PLUNGER, interlock, gear shift rail | 1 | ea | |

| (1) ILLUSTRATION NO. | (2) REFER- ENCE SYMBOLS | (3) FEDERAL STOCK NO. | (4) ORDNANCE STOCK NO. | (5) MFR'S PART NO. | (6) ORDNANCE PART NO. | (7) DESCRIPTION | (8) QUANTITY INCOR- PORATED IN UNIT | (9) UNIT OF ISSUE |
|--|----------------------------------|-----------------------------|------------------------------|------------------------|-----------------------------|--|---|----------------------------|
| GROUP 07—TRANSMISSION—Continued | | | | | | | | |
| 0704—GEAR SHIFT, LEVER, SHAFTS, AND FORKS—Continued | | | | | | | | |
| 07-2 | | 2520-360-7265 | G503-7372447 | WG-4496K WO-A1379 | 7372447 | RETAINER, gear shift lever housing..... | 1 | ea |
| 07-2 | | 2520-737-4971 | G740-7374971 | WG-T90C21 WO-642765 | 7374971 | SHAFT, shifter, low and reverse speed gear..... | 1 | ea |
| 07-2 | | 2520-737-4970 | G740-7374970 | WG-T90-20 WO-642764 | 7374970 | SHAFT, shifter, second and high speed gears..... | 1 | ea |
| 07-2 | | | G741-7351052 | WG-T8B42 WO-642769 | 7351052 | SPRING, compression, S, 0.054 dia stock, $1\frac{1}{32}$ OD, 7 coils, $1\frac{5}{16}$ free lg | 2 | ea |
| 07-2 | | 5340-499-8906 | G740-7374969 | WG-4498B WO-801732 | 7374969 | SPRING, support, gear shift lever..... | 1 | ea |
| 07-2 | | 5310-360-7309 | G503-7372448 | WG-4497 WO-635863 | 7372448 | WASHER, SPRING, TENSION, gear shift lever spring seat | 1 | ea |

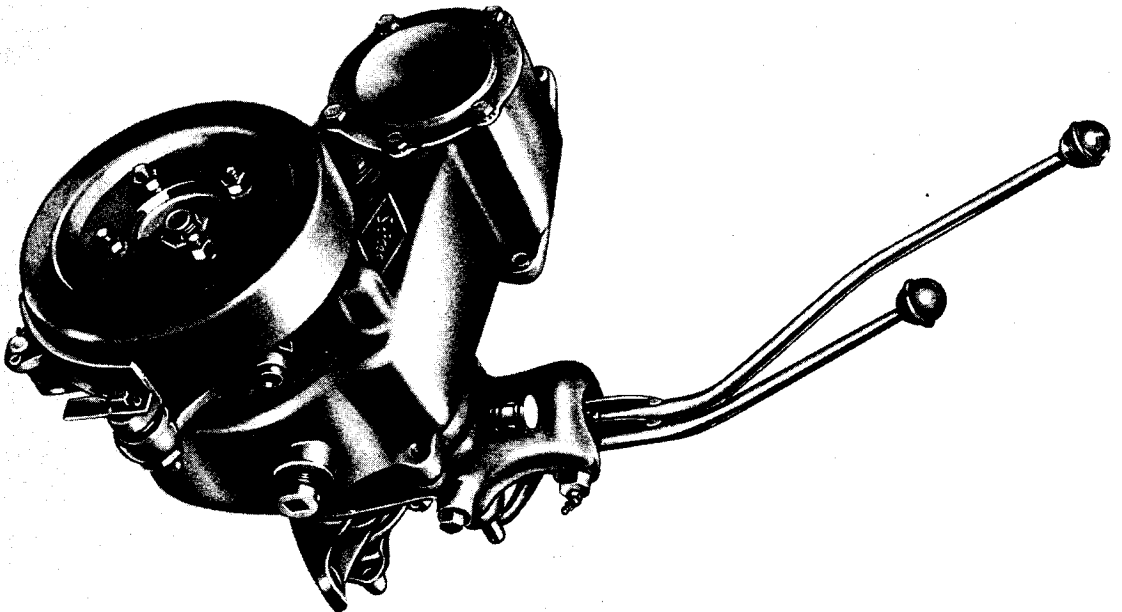
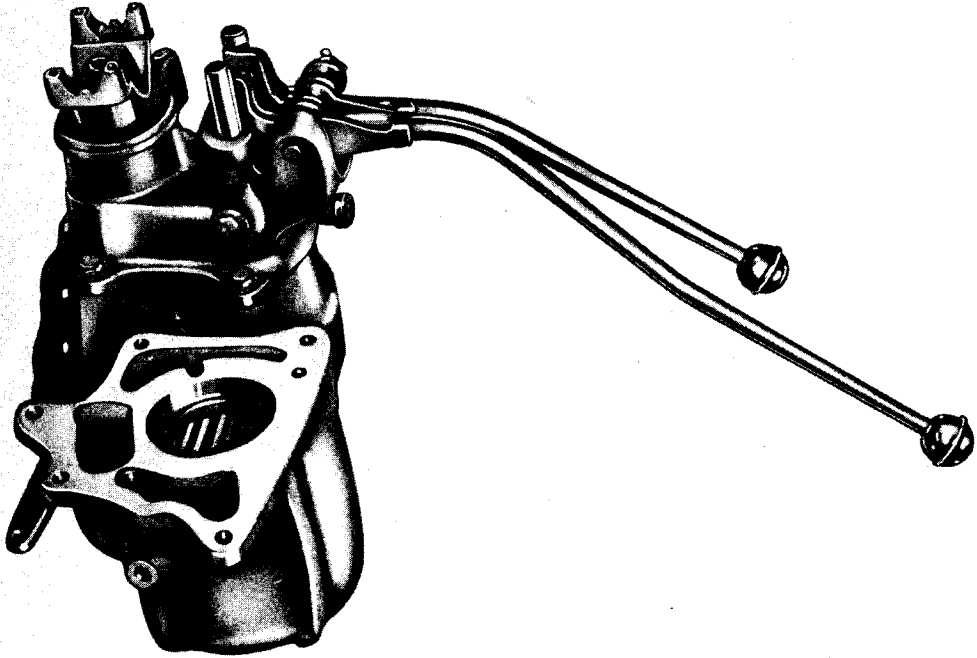
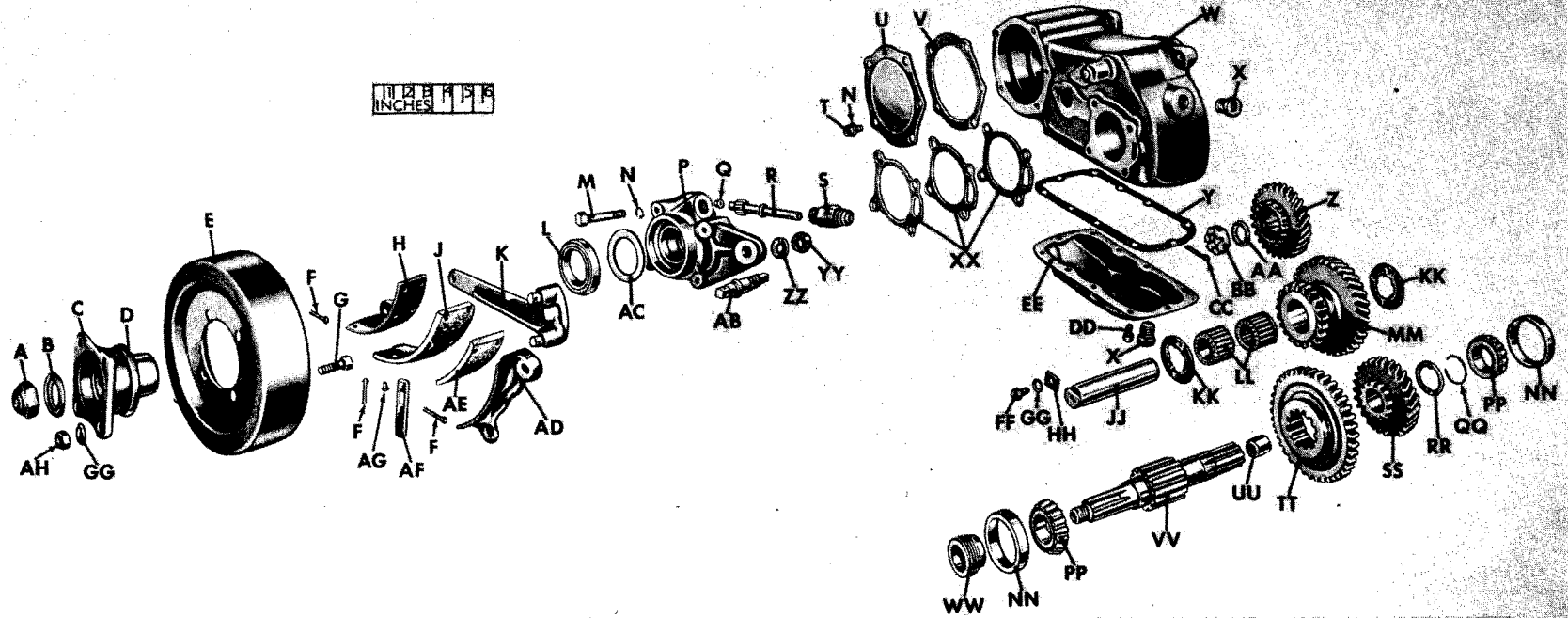

Figure 08-1. Transfer, assy (8329993)

RA PD 181655



| KEY ITEM | PART NO | GROUP | KEY ITEM | PART NO | GROUP | KEY ITEM | PART NO | GROUP |
|-----------|-----------------|--------|-----------------|---------|--------|------------|-----------------|--------|
| A—NUT | 7032635 | 0802.7 | V—GASKET | 7373162 | 0801 | QQ—RING | 7373165 | 0802.5 |
| B—WASHER | 7036380 | 0802.7 | W—CASE | 7375051 | 0801 | RR—WASHER | 7371204 | 0802.7 |
| C—FLANGE | 7371099 | 0802.7 | X—PLUG | 7372879 | 0801 | SS—GEAR | 7697467 | 0802.7 |
| D—SHIELD | 7696479 | 0802.7 | Y—GASKET | 7375053 | 0801 | TT—GEAR | 7697468 | 0802.7 |
| E—DRUM | 8329632 | 1201 | Z—GEAR | 7375132 | 0802.1 | UU—BEARING | 7373115 | 0802.7 |
| F—PIN | 177923 | 1201 | AA—WASHER | 7375131 | 0802.1 | VV—SHAFT | SP-18-362-6 | 0802.7 |
| G—BOLT | 7324918 | 1201 | BB—NUT | 7743652 | 0802.1 | WW—GEAR | 7373166 | 0802.7 |
| H—SHOE | TD-TI-3722-V-48 | 1201 | CC—PIN | 120123 | 0802.1 | —SHIM | 7373158 | 0802.7 |
| J—LINING | SP-330091 | 1201 | DD—BOLT | 217233 | 0801 | XX—SHIM | 7373159 | 0802.7 |
| K—LEVER | 8329633 | 1201 | EE—COVER | 7375052 | 0801 | —SHIM | 7373160 | 0802.7 |
| L—SEAL | 500068 | 0802.7 | FF—SCREW | 180118 | 0802.3 | YY—NUT | 124944 | 1201 |
| M—SCREW | 180132 | 0802.7 | GG—WASHER | 120382 | 0802.3 | ZZ—WASHER | 131205 | 1201 |
| N—WASHER | 120930 | 0801 | HH—PLATE | 7371213 | 0802.3 | AB—PIN | 8329629 | 1201 |
| P—CAP | SP-18-19-33 | 0802.7 | JJ—COUNTERSHAFT | 7375133 | 0802.3 | AC—GASKET | 7373157 | 0802.7 |
| Q—BEARING | 5167516 | 0802.7 | KK—WASHER | 7375135 | 0802.3 | AD—SHOE | TD-TI-722-8-333 | 1201 |
| R—GEAR | 8328480 | 2208.1 | LL—BEARING | 708234 | 0802.3 | AE—LINING | SP-330090 | 1201 |
| S—SLEEVE | 8328481 | 2208.1 | MM—GEAR | 7375134 | 0802.3 | AF—STOP | SP-330150 | 1201 |
| T—SCREW | 180120 | 0801 | NN—CUP | 706821 | 0802.7 | AG—RIVET | TD-RV344 | 1201 |
| U—COVER | 7369850 | 0801 | PP—CONE | 705399 | 0802.7 | AH—NUT | 120369 | 1201 |

RA PD 367264

Figure 08-2. Transfer and related parts—exploded view

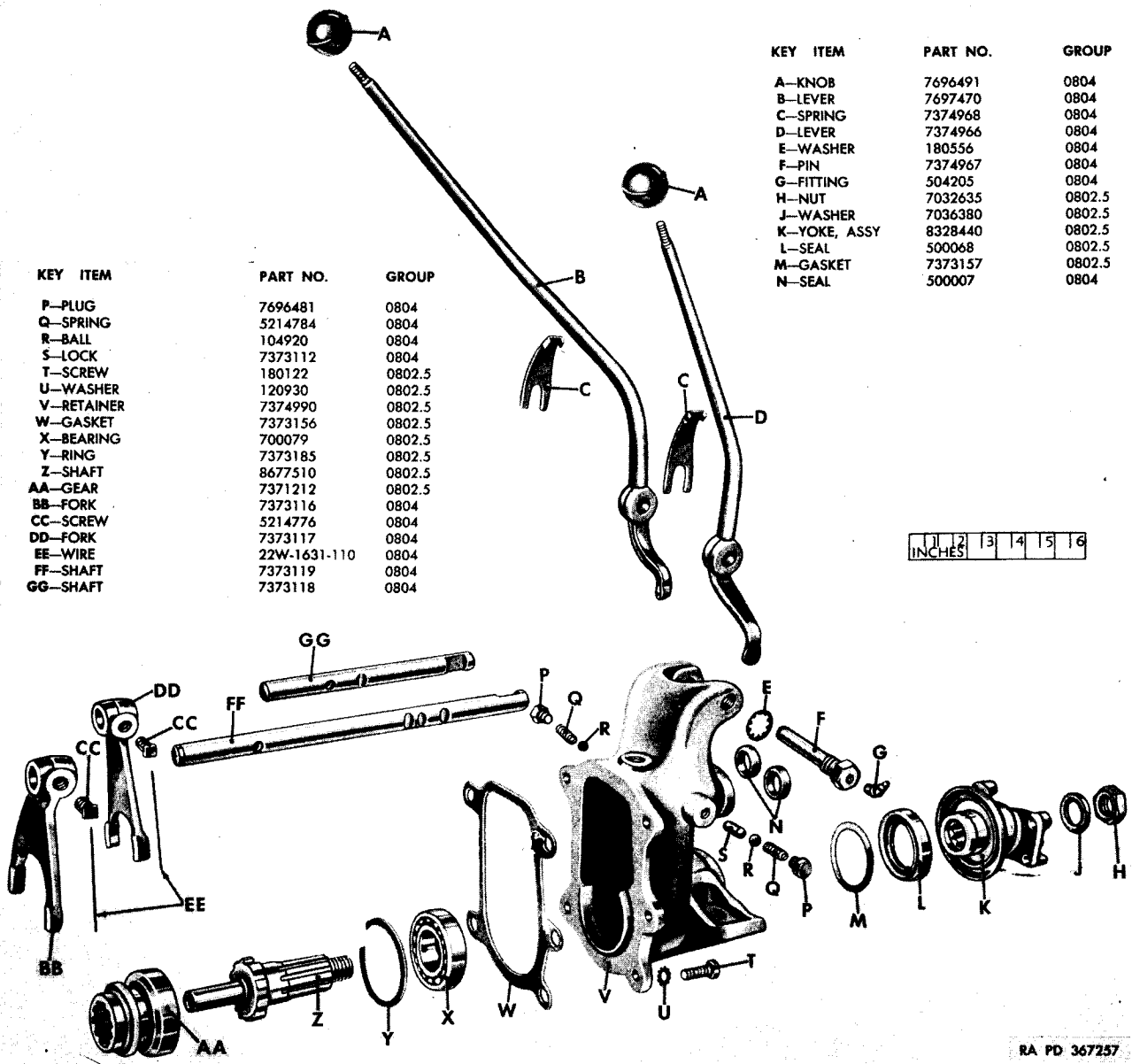

| KEY ITEM | PART NO. | GROUP |
|------------|--------------|--------|
| P—PLUG | 7696481 | 0804 |
| Q—SPRING | 5214784 | 0804 |
| R—BALL | 104920 | 0804 |
| S—LOCK | 7373112 | 0804 |
| T—SCREW | 180122 | 0802.5 |
| U—WASHER | 120930 | 0802.5 |
| V—RETAINER | 7374990 | 0802.5 |
| W—GASKET | 7373156 | 0802.5 |
| X—BEARING | 700079 | 0802.5 |
| Y—RING | 7373185 | 0802.5 |
| Z—SHAFT | 8677510 | 0802.5 |
| AA—GEAR | 7371212 | 0802.5 |
| BB—FORK | 7373116 | 0804 |
| CC—SCREW | 5214776 | 0804 |
| DD—FORK | 7373117 | 0804 |
| EE—WIRE | 22W-1631-110 | 0804 |
| FF—SHAFT | 7373119 | 0804 |
| GG—SHAFT | 7373118 | 0804 |

| KEY ITEM | PART NO. | GROUP |
|--------------|----------|--------|
| A—KNOB | 7696491 | 0804 |
| B—LEVER | 7697470 | 0804 |
| C—SPRING | 7374968 | 0804 |
| D—LEVER | 7374966 | 0804 |
| E—WASHER | 180556 | 0804 |
| F—PIN | 7374967 | 0804 |
| G—FITTING | 504205 | 0804 |
| H—NUT | 7032635 | 0802.5 |
| J—WASHER | 7036380 | 0802.5 |
| K—YOKE, ASSY | 8328440 | 0802.5 |
| L—SEAL | 500068 | 0802.5 |
| M—GASKET | 7373157 | 0802.5 |
| N—SEAL | 500007 | 0804 |

1 2 3 4 5 6
INCHES

RA PD 367257

Figure 08-3. Transfer front bearing retainer and shifter shafts—exploded view

| (1) ILLUSTRATION NO. | (2) REFERENCE SYMBOLS | (3) FEDERAL STOCK NO. | (4) ORDNANCE STOCK NO. | (5) MFR'S PART NO. | (6) ORDNANCE PART NO. | (7) DESCRIPTION | (8) QUANTITY INCORPORATED IN UNIT | (9) UNIT OF ISSUE |
|-------------------------------|--------------------------|--------------------------|---------------------------|--|--------------------------|---|--------------------------------------|----------------------|
| GROUP 08—TRANSFER | | | | | | | | |
| 0800—TRANSFER ASSEMBLY | | | | | | | | |
| | | 5805-737-1759 | G503-7371759 | WO-A147 | 7371759 | BOLT, hex-hd, S, 1/2-20NC x 3 (case support)..... | 1 | ea |
| | H1 | 012-0371 | H001-4167681 | | 120371 | NUT, pl, hex, lt, s-fin, S, cd- or zn-pltd, 1/2-20NF-2.. | 1 | ea |
| | H1 | 5810-012-0384 | H001-7025801 | | 120384 | WASHER, med, S, cd- or zn-pltd, 1/2 in..... | 1 | ea |
| | H1 | 5810-012-0396 | H001-7043801 | | 120396 | WASHER, flat, S, cd- or zn-pltd, 1 1/8 ID, 1 1/8 OD, 0.095 thk | 1 | ea |
| 07-3 | | 2520-495-9515 | G503-7371037 | WO-A6740 | 7371037 | CUP, retaining, case support insulator..... | 1 | ea |
| | | 2520-737-2878 | G740-7372878 | WO-644122 | 7372878 | GASKET, transfer to transmission..... | 1 | ea |
| | | 2520-737-5081 | G740-7375081 | WO-801043 | 7375081 | INSULATOR, case supporting..... | 1 | ea |
| | | 2520-737-5082 | G740-7375082 | WO-801042 | 7375082 | SNUBBER, case support insulator..... | 1 | ea |
| 08-1 | | | G758-8329993 | WO-806044 | 8329993 | TRANSFER ASSY, w/BRAKE..... | 1 | ea |
| | H1 | 012-0233 | H001-5420561 | | 120233 | BOLT, cap, hex-hd, S, cd- or zn-pltd, 3/8-16NC-3 x 1.. | 1 | ea |
| | H1 | 5805-012-2138 | H001-5420581 | | 122138 | SCREW, cap, hex-hd, S, cd- or zn-pltd, 3/8-16NC-3 x 1 1/8 | 4 | ea |
| | H1 | 5810-012-0930 | H001-7017685 | | 120930 | WASHER, lock, ext-teeth, S, phos-ctd, 3/8 in..... | 5 | ea |
| | H1 | 5810-010-3345 | H001-1530013 | | 103345 | WASHER, FLAT, S, 2 1/2 ID, 1 1/2 OD, 1/16 thk (case mtg support) | 1 | ea |
| 0801—CASE AND COVERS | | | | | | | | |
| 08-2 | | 2520-737-5051 | G740-7375051 | SP-18-15-18 WG-J2A1 WO-644319 | 7375051 | CASE, transfer..... | 1 | ea |
| 08-2 | | 2520-737-5052 | G740-7375052 | SP-7906X WG-1AJ2A1 1/2 WO-801328 | 7375052 | COVER, bottom..... | 1 | ea |
| 08-2 | H1 | 021-7233 | H101-0217233 | | 217233 | BOLT, LOCK WASHER, hex-hd, S, 5/16-18NC-2 x 3/4.. | 10 | ea |
| 08-2 | | 2520-736-9850 | G740-7369850 | SP-18-267-5 WG-J2A48A WO-802088 | 7369850 | COVER, rear..... | 1 | ea |
| 08-2 | H1 | | H001-5454521 | | 180120 | SCREW, cap, hex-hd, S, 85,000 psi-yield strength, cd- or zn-pltd, 3/8-16NC-3 x 3/4 | 5 | ea |
| 08-2 | H1 | 5810-012-0930 | H001-7017685 | | 120930 | WASHER, lock, ext-teeth, S, phos-ctd, 3/8 in..... | 5 | ea |
| 08-2 | | 2520-737-5053 | G740-7375053 | SP-18-155-2 WG-J2-57 WO-A954 | 7375053 | GASKET, bottom cover..... | 1 | ea |
| 08-2; 20-4, 5 | | 2520-737-3162 | G503-7373162 | SP-18-324-2 WO-A1509 | 7373162 | GASKET, rear cover..... | 1 | ea |

| | | | | | | | | | |
|---------------------------------------|-----|---------------|--------------|--------------------------------------|---------|---|---|----|--|
| | | 2520-737-1210 | G503-7371210 | SP-5951X WG-AJ2-87 WO-A934 | 7371210 | PLUG, air vent (transfer case) (used on vehicles after serial No. 23359) | 1 | ea | |
| 08-2 | | 4730-737-2879 | G740-7372879 | SP-18-39-3 WO-801660 | 7372879 | PLUG, PIPE, sq, ck-hd, MI, 1/2 (drain and filler) | 2 | ea | |
| 0802.1—INPUT GEAR | | | | | | | | | |
| 08-2 | | 2520-737-5132 | G740-7375132 | SP-18-8-19 WG-J2A11 WO-A10469 | 7375132 | GEAR, SPUR, input (26T) (on transmission mainshaft) | 1 | ea | |
| 07-3; 08-2 | | 5310-360-6911 | G503-7743652 | WG-T9-50P WO-A520 | 7743652 | NUT, hex, S, 7/8-16NC-2 | 1 | ea | |
| 07-3; 08-2 | H1 | 012-0123 | H001-4417741 | | 120123 | PIN, cotter, split, S, cd- or zn-pltd, 1/8 x 1 1/4 | 1 | ea | |
| 07-3; 08-2 | | 5310-360-8171 | G740-7375131 | WG-T84J50-1/2A WO-A1410 | 7375131 | WASHER, flat, 29/32 ID, 1 1/16 OD, 5/32 thk | 1 | ea | |
| 0802.3—COUNTERSHAFT | | | | | | | | | |
| 08-2 | H12 | | H012-0708234 | | 708234 | BEARING, roller, journal, MIL-STD-CODE 341-01854-0000 (solid rollers, no races, type 2, 1.1250 shaft dia, 1.6250 housing bore, 1.3750 operating space) (countershaft) | 2 | ea | |
| 08-2 | | 2520-737-5133 | G740-7375133 | SP-18-187-4 WG-J2A35 WO-642188 | 7375133 | COUNTERSHAFT | 1 | ea | |
| 08-2 | | 2520-737-5134 | G740-7375134 | SP-18-5-7 WG-J2A10A WO-642189 | 7375134 | GEAR (34T-21T) | 1 | ea | |
| 08-2 | | 2520-495-7178 | G503-7371213 | SP-31-246-2 WG-J2-36 WO-A1001 | 7371213 | PLATE, locking | 1 | ea | |
| 08-2 | H1 | 018-0118 | H001-5454481 | | 180118 | SCREW, cap, hex-hd, S, 85,000 psi yield strength, cd- or zn-pltd, 3/8-16NC-3 x 5/8 | 1 | ea | |
| 08-2 | H1 | 5310-012-0382 | H001-7025741 | | 120382 | WASHER, lock, med, S, cd- or zn-pltd, 3/8 in (intermediate shaft locking plate screw) | 1 | ea | |
| 08-2 | | 3120-737-5135 | G740-7375135 | SP-884W WG-J2B30 WO-642191 | 7375135 | WASHER, thrust, gear | 2 | ea | |
| 0802.5—FRONT AXLE OUTPUT SHAFT | | | | | | | | | |
| 08-3 | H12 | 100-0082 | H012-1303030 | | 700079 | BEARING, ball, MIL-STD-CODE 111-03002-0000 (rad, SR, lt, non-loading groove, 1.811 bore, 2.4409 OD, 0.6299 width (clutch gear shaft) | 1 | ea | |
| 08-3 | | 2520-737-3156 | G503-7373156 | SP-18-223-2 WG-J2-60 WO-A957 | 7373156 | GASKET, front bearing cap | 1 | ea | |

0802.5

200

| (1) ILLUSTRATION NO. | (2) REFERENCE SYMBOLS | (3) FEDERAL STOCK NO. | (4) ORDNANCE STOCK NO. | (5) MFR'S PART NO. | (6) ORDNANCE PART NO. | (7) DESCRIPTION | (8) QUANTITY INCORPORATED IN UNIT | (9) UNIT OF ISSUE |
|---|--------------------------|--------------------------|---------------------------|-------------------------------------|--------------------------|---|--------------------------------------|----------------------|
| GROUP 08—TRANSFER—Continued | | | | | | | | |
| 0802.5—FRONT AXLE OUTPUT SHAFT—Continued | | | | | | | | |
| 08-3 | | 2520-737-3157 | G503-7373157 | SP-18-223-3 WG-J233 WO-A1134 | 7373157 | GASKET, front bearing cap oil seal..... | 1 | ea |
| 08-3 | | 2520-495-7097 | G503-7371212 | SP-18-466-1 WG-J2-15 WO-A992 | 7371212 | GEAR, clutch (10 int-teeth, 1.088 bore, 1.755 face, 2.311 OD) | 1 | ea |
| 08-3 | | 2520-737-4990 | G740-7374990 | SP-18-19-32 WO-801183 | 7374990 | RETAINER, front bearing..... | 1 | ea |
| 08-3 | H1 | 018-0122 | H001-5454561 | | 180122 | SCREW, cap, hex-hd, S, 85,000 psi yield strength, cd- or zn-pltd, 3/8-16NC-3 x 1 | 5 | ea |
| 08-3 | H1 | 5310-012-0930 | H001-7017685 | | 120930 | WASHER, lock, ext-teeth, S, phos-ctd, 3/8 in..... | 5 | ea |
| 08-3 | | 5340-737-3185 | G503-7373185 | SP-22-381-19 WO-A976 | 7373185 | RING, snap, clutch gear shaft bearing (optional w/RING, WO-R6A7 1/2) | 1 | ea |
| 08-2 | | 5340-737-3165 | G503-7373165 | WG-R6A7 1/2 WO-639429 | | RING, snap, clutch gear shaft bearing (optional w/RING 7373185) | 1 | ea |
| | | | | SP-18-381-2 WG-J2-32 WO-A991 | 7373165 | RING, snap, thrust washer..... | 1 | ea |
| | | | G758-8331793 | SP-330152 WO-811687 | 8331793 | SEAL, felt (front yoke)..... | 1 | ea |
| 08-3 | H13 | | H013-0500068 | | 500068 | SEAL, oil, type ML, 1 1/16 x 2.506 x 1/2 (front)..... | 1 | ea |
| 08-3 | | | | SP-18-362-7 WG-J2A3 WO-806037 | 8677510 | SHAFT, output..... | 1 | ea |
| | | | G758-8329674 | SP-310134X WO-807892 | 8329674 | SHAFT, output, w/NUT, and WASHER, assy..... | 1 | ea |
| | | 2520-769-6494 | G503-7696494 | SP-5962X WG-AJ2-16 WO-A1111 | 7696494 | SHIELD, dust, w/SLINGER, assy (front yoke)..... | 1 | ea |
| | | | | | 7696479 | Composed of: 1 SHIELD | | |
| | | | | | 7371371 | 1 SLINGER | | |
| | | 2530-769-6479 | G503-7696479 | SP-715W WO-A979 | 7696479 | SHIELD, dust (companion flange, front)..... | 1 | ea |
| | | 2520-495-9524 | G503-7371371 | SP-712W WG-J2-17 WO-A978 | 7371371 | SLINGER, dust, companion flange and front yoke..... | 1 | ea |

201

| | | | | | | | | | |
|--------------------------------------|-----|---------------|--------------|--|---------|---|---|----|--|
| 08-3 | | | G758-8328440 | SP-2-4-88X WG-A4714 WO-A1106 WG-4714C SP-2-4-1421 WO-807695 | 8328440 | YOKE, front propeller shaft to transfer, w/SHIELD, assy.. | 1 | ea | |
| | | | | | | YOKE, propeller shaft to transfer..... | 1 | ea | |
| 08-3 | H1 | | H101-7032635 | | 7032635 | NUT, hex, Huglock type, 3/4-16NF-2 (output shaft).... | 1 | ea | |
| 08-3 | H1 | | H001-7036380 | | 7036380 | WASHER, flat, 3/4 in. (output shaft) (supersedes WASHER 7372868) | 1 | ea | |
| | | | G740-7372868 | SP-145W WG-J2-50 1/2 WO-A1028 | 7372868 | WASHER, sp, flat, 3/4 in. (superseded by WASHER 7036380) | 1 | ea | |
| 0802.7-REAR AXLE OUTPUT SHAFT | | | | | | | | | |
| 08-2 | | 3120-737-3115 | G503-7373115 | SP-18-24-1 WO-A987 | 7373115 | BEARING, bushing type, bz, 0.627 ID, 0.750 OD, 0.930 width (pilot, output clutch gear shaft) | 1 | ea | |
| 08-2; 12-3 | | 3110-516-7516 | G742-5167516 | SP-475-2 WG-T54A172A WO-A985 | 5167516 | BEARING, bushing type, S, 0.2550 ID, 0.3145 OD, 1 1/2 width (speedometer drive gear) | 1 | ea | |
| 08-2; 12-3 | | | | SP-18-19-33 WG-J2A7B TD-3711H8FIN WO-806024 | | CAP..... | 1 | ea | |
| | | | G758-8328478 | WG-AJ2A7B WO-806045 | 8328478 | CAP, w/BEARING, assy..... | 1 | ea | |
| 08-2; 12-3 | H1 | 018-0132 | H001-5454761 | | 180132 | SCREW, cap, hex-hd, S, 85,000 psi yield strength, cd- or zn-pltd, 3/8-16NC-3 x 2 1/4 | 4 | ea | |
| 08-2; 12-3 | H1 | | H001-7017685 | | 120930 | WASHER, lock, ext-teeth, S, phos-ctd, 3/8 in..... | 4 | ea | |
| 08-2 | H12 | | H012-6136260 | | 705399 | CONE, tapered roller bearing, MIL-STD-CODE 711- 14131-3000 (includes roller and cage, SR, 1.3125 bore, 0.7710 width) (output shaft bearing) | 2 | ea | |
| 08-2 | H12 | | H012-6217320 | | 706821 | CUP, tapered roller bearing, MIL-STD-CODE 711- 14276-1000 (SR, 2.7170 OD, 0.6250 width) (output shaft bearing) | 2 | ea | |
| 08-2; 12-3 | | | G503-7371099 | SP-2-1-1191 WO-A996 | 7371099 | FLANGE, companion, rear..... | 1 | ea | |
| | | 2520-737-1035 | G503-7371035 | WG-1A4713 SP-2-1-68X WO-116714 | 7371035 | FLANGE, companion, rear, assy..... | 1 | ea | |
| | | | | | 7371099 | Composed of: | | | |
| | | | | | 7696479 | 1 FLANGE | | | |
| | | | | | 7032635 | 1 SHIELD | | | |
| 08-2; 12-3 | H1 | | H101-7032635 | | 7032635 | NUT, hex, Huglock type, 3/4-16NF-2..... | 1 | ea | |
| 08-2; 12-3 | | | G740-7372868 | SP-145W WO-A1028 | 7372868 | WASHER, flat, 3/4 in. (superseded by WASHER 7036380) | 1 | ea | |
| 08-2; 12-3 | H1 | | H001-7036380 | | 7036380 | WASHER, flat, 3/4 in. (supersedes WASHER 7372868).. | 1 | ea | |

0802.7

0802.7

202

| (1) ILLUSTRATION NO. | (2) REFERENCE SYMBOLS | (3) FEDERAL STOCK NO. | (4) ORDNANCE STOCK NO. | (5) MFR'S PART NO. | (6) ORDNANCE PART NO. | (7) DESCRIPTION | (8) QUANTITY INCORPORATED IN UNIT | (9) UNIT OF ISSUE |
|--|--------------------------|--------------------------|------------------------------|--|--------------------------|--|--------------------------------------|----------------------|
| GROUP 08—TRANSFER—Continued | | | | | | | | |
| 0802.7—REAR AXLE OUTPUT SHAFT—Continued | | | | | | | | |
| 08-2; 12-3 | | 2520-737-3157 | G503-7373157 | SP-18-223-3 WG-J233 WO-A1134 | 7373157 | GASKET, bearing cap oil seal..... | 1 | ea |
| 08-2 | | 2520-737-3166 | G503-7373166 | SP-18452-2 WG-J2-169 WO-A1511 | 7373166 | GEAR, drive, speedometer (4T, 1.775 OD)..... | 1 | ea |
| 08-2 | | 2520-769-7467 | G740-7697467 | SP-18-8-18 WG-J2A8 WO-A15044 | 7697467 | GEAR, HELICAL (26T, 3.961 OD)..... | 1 | ea |
| 08-2 | | 2520-769-7468 | G740-7697468 | SP-18-8-17 WG-J2A12 WO-A15045 | 7697468 | GEAR, sliding (39T, 5.757 OD)..... | 1 | ea |
| | H1 | | H101-7032635 G758-8331793 | SP-330152 WO-811687 | 7032635 8331793 | NUT, hex, Huglock type, $\frac{3}{4}$ -16NF-2..... SEAL, dust (companion flange, rear)..... | 1 1 | ea ea |
| 08-2; 12-3 | H13 | | H013-0500068 | | 500068 | SEAL, oil, type ML, $1\frac{1}{16}$ x 2.506 x $\frac{1}{2}$ (rear)..... | 1 | ea |
| 08-2 | | | | SP-18-862-6 WG-J2A4 WO-806038 WG-4J2A4 SP-310057X WO-806036 | 8677509 | SHAFT, output..... SHAFT, output, w/BEARING, assy..... | 1 1 | ea ea |
| | | | G758-8328479 | WG-AJ2A4 WO-807767 | 8328479 | SHAFT, output, w/NUT and WASHER, assy..... | 1 | ea |
| 08-2; 12-3 | | 2530-769-6479 | G503-7696479 | SP-715W WG-J2-16 WO-A979 | 7696479 | SHIELD, dust (companion flange, rear)..... | 1 | ea |
| 08-2 | | 2520-737-3158 | G503-7373158 | SP-18-228-7 WG-J2-59 WO-A982 | 7373158 | SHIM, rear bearing cap (0.003 thk)..... | ‡ | ea |
| 08-2 | | | G503-7373159 | SP-18-228-8 WG-J2-59A WO-A983 | 7373159 | (0.010 thk)..... | ‡ | ea |
| 08-2 | | 2520-737-3160 | G503-7373160 | SP-18-228-9 WG-J2-59B WO-A984 | 7373160 | (0.031 thk)..... | ‡ | ea |

| | | | | | | | | |
|---|-----|---------------|--------------|--------------------------------------|-------------------|--|---|----|
| | | 5310-737-2868 | G740-7372868 | SP-145W WO-A1028 | 7372868 | WASHER, FLAT, $\frac{3}{4}$ in. (superseded by WASHER 7036380) | 1 | ea |
| 08-2 | H1 | | H001-7036380 | | 7036380 | WASHER, FLAT, $\frac{3}{4}$ in. (supersedes WASHER 7372868). | 1 | ea |
| | | 3120-737-1204 | G503-7371204 | SP-710W WG-J2-30 WO-A990 | 7371204 | WASHER, thrust | 1 | ea |
| 0804—SHIFTER SHAFTS, FORKS, AND GEAR SHIFT HAND LEVERS | | | | | | | | |
| 08-3 | H2 | | H002-0100140 | | 104920 | BALL, alloy-S, grade 2, $\frac{3}{8}$ in. (detent, shifter shaft) | 2 | ea |
| 08-3 | H16 | | H016-0504205 | | 504205 | FITTING, lubr, hyd, 45 deg, $\frac{1}{4}$ -28NF, male (shifter lever pivot pin) | 1 | ea |
| 08-3 | | 2520-495-7100 | G503-7373117 | SP-18-66-7 WG-J2-24 WO-A960 | 7373117 | FORK, shifter, output clutch gear | 1 | ea |
| 08-3 | | 3120-495-7099 | G503-7373116 | SP-18-66-1 WG-J2-23 WO-A959 | 7373116 | FORK, shifter, output shaft sliding gear | 1 | ea |
| 08-3 | | 5305-521-4776 | G503-5214776 | SP-745D WO-A963 | 5214776 | SCREW, set, S, $\frac{3}{8}$ -24NF x 0.72 (dld-hd) | 2 | ea |
| 08-3 | H9 | | H009-0102230 | | 22-W-1631 -110 | WIRE, S, carbon, low, annealed, soft, black, dia 0.0625 in. (pivot pin set screw) | † | lb |
| 08-3 | | 5980-741-1761 | G503-7696491 | SP-39Q20 WG-J2-83 WO-A971 | 7696491 | KNOB, gear shift lever | 2 | ea |
| 08-3 | | 2520-769-7470 | G740-7697470 | SP-25Q1250 WG-J2A80A WO-801330 | 7697470 | LEVER, hand, gear shift, direct and underdrive | 1 | ea |
| 08-3 | | 2520-737-4966 | G740-7374966 | SP-25Q1251 WG-J2A81A WO-801331 | 7374966 | LEVER, hand, gear shift, front wheel drive | 1 | ea |
| 08-3 | | 2520-495-7088 | G503-7373112 | SP-18-12-1 WG-J286 WO-A965 | 7373112 | LOCK, gear shifter shaft | 1 | ea |
| 08-3 | | 5315-737-4967 | G740-7374967 | SP-471SP WG-J2A85 WO-800818 | 7374967 | PIN, pivot, gear shift hand lever | 1 | ea |
| 08-3 | H1 | 5310-018-0556 | H101-0180556 | | 180556 | WASHER, lock, int-teeth, hv, S, cd- or zn-pltd, $\frac{5}{8}$ in. | 1 | ea |
| 08-3 | | 2520-769-6481 | G503-7696481 | SP-854D WG-J2-155 WO-A967 | 7696481 | PLUG, hex-hd, $\frac{1}{16}$ -20NF-3 x $\frac{5}{16}$ (shifter shaft poppet ball spring) | 2 | ea |
| 08-3 | H13 | | H013-0500007 | | 500007 | SEAL, oil, type ML, $\frac{5}{8}$ x 1.128 x $\frac{3}{8}$ (gear shifter shaft) | 2 | ea |
| 08-3 | | 2520-495-7101 | G503-7373118 | SP-18-67-2 WG-J2-21 WO-A962 | 7373118 | SHAFT, shifter, clutch gear fork | 1 | ea |

| (1) ILLUSTRATION NO. | (2) REFER- ENCE SYMBOLS | (3) FEDERAL STOCK NO. | (4) ORDNANCE STOCK NO. | (5) MFR'S PART NO. | (6) ORDNANCE PART NO. | (7) DESCRIPTION | (8) QUANTITY INCOR- PORATED IN UNIT | (9) UNIT OF ISSUE |
|---|----------------------------------|-----------------------------|------------------------------|------------------------------------|-----------------------------|--|---|----------------------------|
| GROUP 08—TRANSFER—Continued | | | | | | | | |
| 0804—SHIFTER SHAFTS, FORKS, AND GEAR SHIFT HAND LEVERS—Continued | | | | | | | | |
| 08-3 | | 2520-737-3119 | G503-7373119 | SP-18-67-5 WG-J2-20 WO-A1504 | 7373119 | SHAFT, shifter, sliding gear fork..... | 1 | ea |
| 08-3 | | 5340-737-4968 | G740-7374968 | SP-97Q14 WG-J2A82 WO-801332 | 7374968 | SPRING, gear shift hand lever..... | 2 | ea |
| 08-3 | | 5340-521-4784 | G503-5214784 | SP-22-72-5 WG-J2-42 WO-A966 | 5214784 | SPRING, shifter shaft poppet ball..... | 2 | ea |

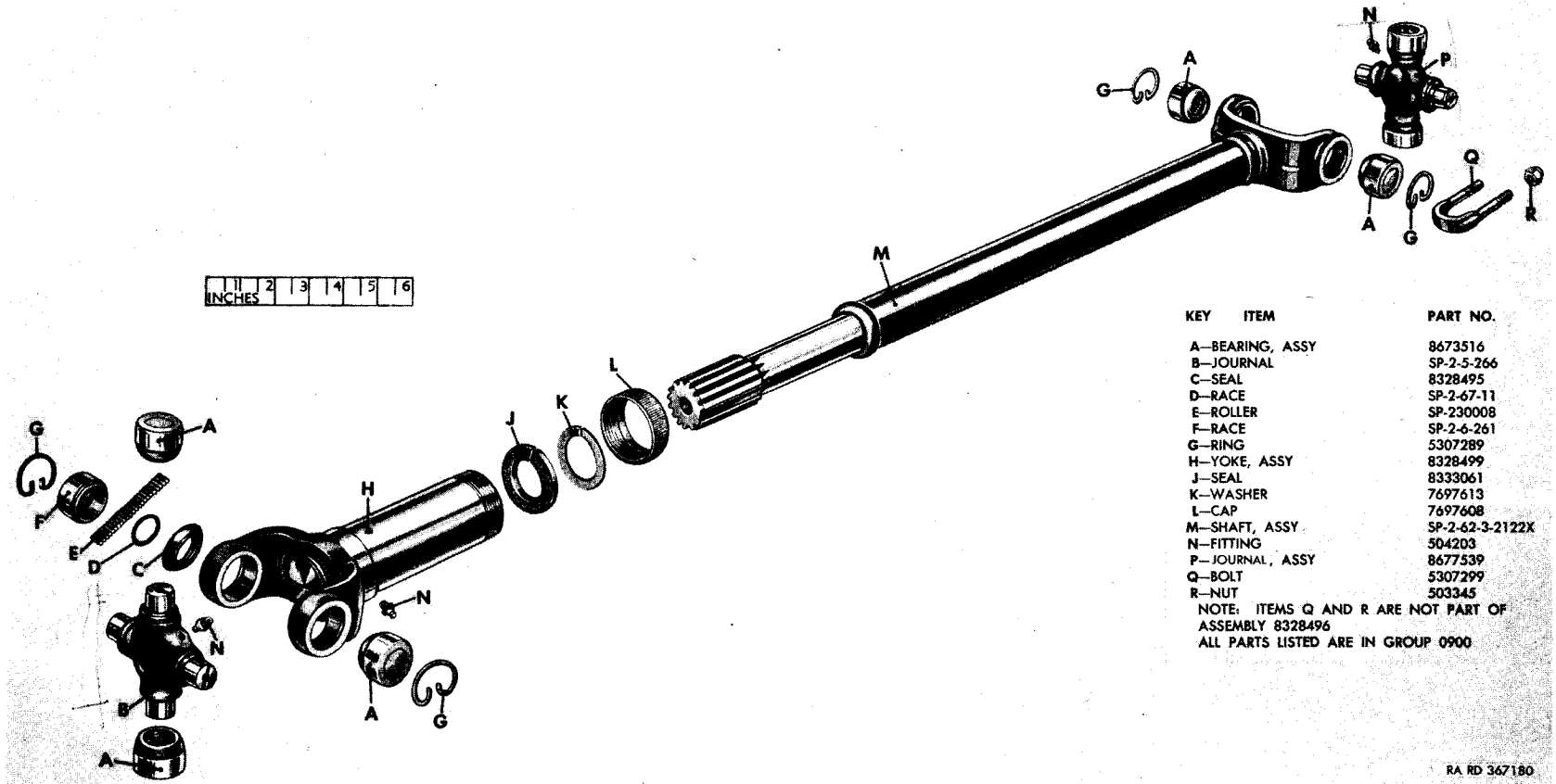

RA RD 367180

Figure 09-1. Propeller shaft, front, assy (8328496)—exploded view

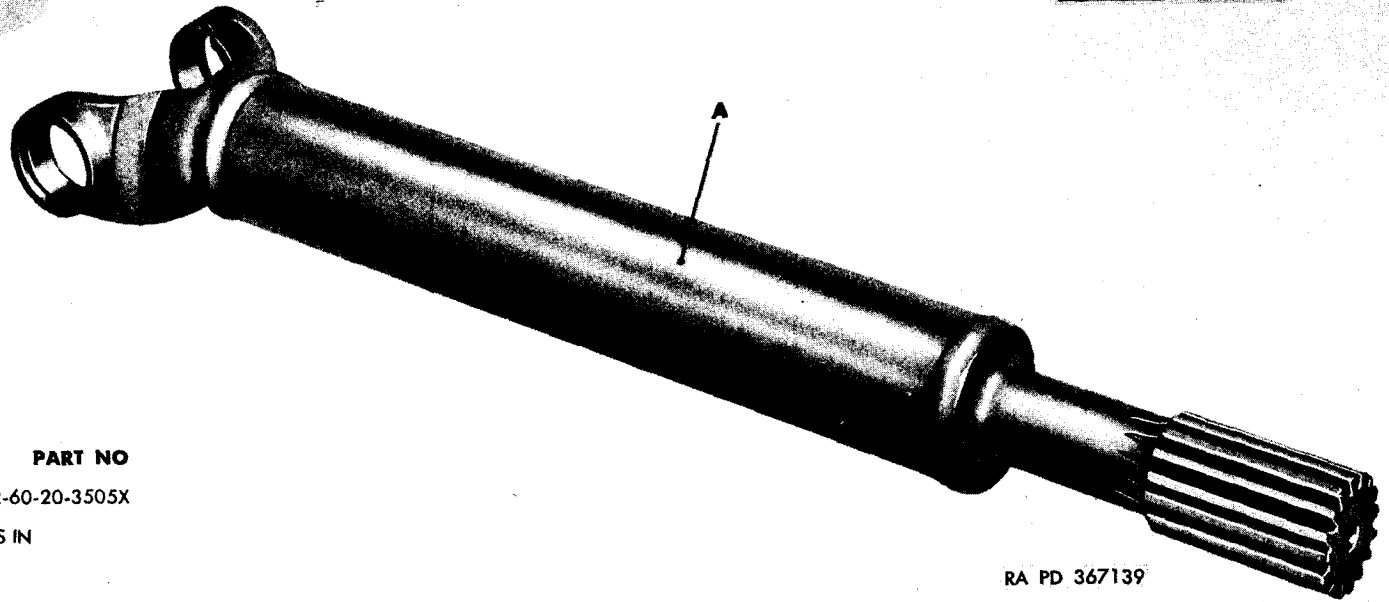

| KEY ITEM | PART NO |
|----------|------------------|
| A—SHAFT | SP-2-60-20-3505X |

NOTE: PART LISTED IS IN
GROUP 0900

Figure 09-2. Propeller shaft, rear (M170)

| (1) | (2) | (3) | (4) | (5) | (6) | (7) | (8) | (9) |
|------------------|-------------------|-------------------|--------------------|------------------------------|-------------------|---|-------------------------------|---------------|
| ILLUSTRATION NO. | REFERENCE SYMBOLS | FEDERAL STOCK NO. | ORDNANCE STOCK NO. | MFR'S PART NO. | ORDNANCE PART NO. | DESCRIPTION | QUANTITY INCORPORATED IN UNIT | UNIT OF ISSUE |
| | | | | | | GROUP 09—PROPELLER SHAFT AND UNIVERSAL JOINTS | | |
| | | | | | | 0900—PROPELLER SHAFT AND UNIVERSAL JOINTS | | |
| | | 2520-769-7611 | G740-7697611 | SP-2-95-39 WO-802311 | 7697611 | BAR, tie, universal joint..... | 3 | ea |
| 09-1 | | | | SP-2-6-118X WO-807779 | 8673516 | BEARING, universal joint, assy..... | 16 | ea |
| 09-1 | | 5305-530-7299 | G085-5307299 | SP-2-94-29 WO-A490 | 5307299 | BOLT, "U", S, 5/16-24NF-3 (universal joint bearing)..... | 6 | ea |
| 09-1 | H1 | 050-3345 | H001-4040521 | | 503345 | NUT, self-locking, hex, S, cd- or zn-pltd, 5/16-24NF-3..... | 12 | ea |
| 09-1 | | 2520-769-7608 | G740-7697608 | SP-2-14-19 WO-113373 | 7697608 | CAP, dust, universal joint sleeve yoke..... | 2 | ea |
| | | | | SP-2-5-328X WO-807780 | 8673517 | CROSS ASSEMBLY JOURNAL, universal joint, assy..... | 4 | ea |
| 09-1 | H16 | 050-4203 | H016-0504203 | | 504203 | FITTING, lubr, hyd type, styie No. 1, S, cd- or zn-pltd, 1/4-28NF, male (ball check valve (2), universal joint journal (4)) (supersedes (4) PLUG SP-230007) | 6 | ea |
| 09-1 | | | | WO-807781 | 8677539 | JOURNAL ASSY, w/BEARING and tie BAR..... | 3 | ea |
| 09-1 | | | | SP-2-5-266 WO-A1427 | | JOURNAL, universal joints..... | 4 | ea |
| | | | | SP-230007 WO-119752 | | PLUG, universal joint journal (superseded by FITTING 504203) | 4 | ea |
| 09-1 | | | | SP-2-67-11 WO-119733 | | RACE, needle bearing, inner, universal joint..... | 16 | ea |
| 09-1 | | | | SP-2-6-261 WO-119731 | | RACE, needle bearing, outer, universal joint..... | 16 | ea |
| 09-1 | | | G503-5307289 | SP-2-7-29 WO-A945 | 5307289 | RING, snap, universal joint journal bearing..... | 16 | ea |
| 09-1 | | | | SP-230008 WO-119732 | | ROLLER, needle bearing, universal joint..... | 368 | ea |
| 09-1 | | | G758-8328495 | SP-2-86-69 WO-807801 | 8328495 | SEAL, dust, universal joint bearing..... | 16 | ea |
| 09-1 | | | G758-8333061 | SP-2-16-93 WO-120127 | 8333061 | SEAL, PLAIN, ru, split, 1 ID, 1 3/4 OD, 5/16 thk (packing, sliding yoke) (supersedes WASHER 7702465) | 2 | ea |
| 09-1 | | | | SP-2-62-3-2122X WO-119706 | | SHAFT, propeller, front, assy..... | 1 | ea |
| 09-1 | | | G758-8328496 | SP-200121-1 WO-807691 | 8382496 | SHAFT, propeller, front, w/universal JOINTS, assy..... | 1 | ea |

207

0900

| (1) ILLUSTRATION NO. | (2) REFER- ENCE SYMBOLS | (3) FEDERAL STOCK NO. | (4) ORDNANCE STOCK NO. | (5) MFR'S PART NO. | (6) ORDNANCE PART NO. | (7) DESCRIPTION | (8) QUANTITY INCOR- PORATED IN UNIT | (9) UNIT OF ISSUE |
|-------------------------|----------------------------------|-----------------------------|------------------------------|-------------------------------|-----------------------------|---|---|----------------------------|
| | | | | | | GROUP 09—PROPELLER SHAFT AND UNIVERSAL JOINTS—Continued | | |
| | | | | | | 0900—PROPELLER SHAFT AND UNIVERSAL JOINTS—Continued | | |
| | | | | SP-2-60-20-1519 WO-119705 | | SHAFT, propeller, rear, assy (superseded by SHAFT SP-2-60-20-1519X) | 1 | ea |
| | | | | SP-2-60-20-1519X WO-118516 | | SHAFT, propeller, rear, assy (supersedes SHAFT SP-2-60-20-1519) | 1 | ea |
| | | | G758-8328497 | SP-200122-1 WO-807690 | 8382497 | SHAFT, propeller, rear, w/universal JOINTS, assy..... | 1 | ea |
| 09-2 | | | | SP-2-60-20-3505X WO-120203 | | SHAFT, rear (M170)..... | 1 | ea |
| 09-2 | | | G758-8333283 | SP-200122-2 WO-810607 | 8333283 | SHAFT, rear, assy (M170)..... | 1 | ea |
| | | 5310-770-2465 | G503-7702465 | SP-2-16-53 WO-A943 | 7702465 | WASHER, cork, split, universal joint sleeve yoke dust cap (1 ID, 1 ³ / ₄ OD, 5/ ₁₆ thk) (superseded by SEAL 8333061) | 2 | ea |
| 09-1 | | 5310-769-7613 | G740-7697613 | SP-2-15-13 WO-113387 | 7697613 | WASHER, split, S, universal joint sleeve yoke dust cap (1.035 ID, 1.505 OD, 0.036 thk) | 2 | ea |
| | | | G758-8328498 | SP-2-2-459 WO-807784 | 8328498 | YOKE, flange, rear propeller shaft to transfer..... | 1 | ea |
| 09-1 | | | G758-8328499 | SP-2-3-1111X WO-119707 | 8328499 | YOKE, sleeve, front propeller shaft, assy..... | 1 | ea |
| | | | G758-8329700 | SP-2-3-1131X WO-119704 | 8329700 | YOKE, sleeve, rear propeller shaft, assy..... | 2 | ea |

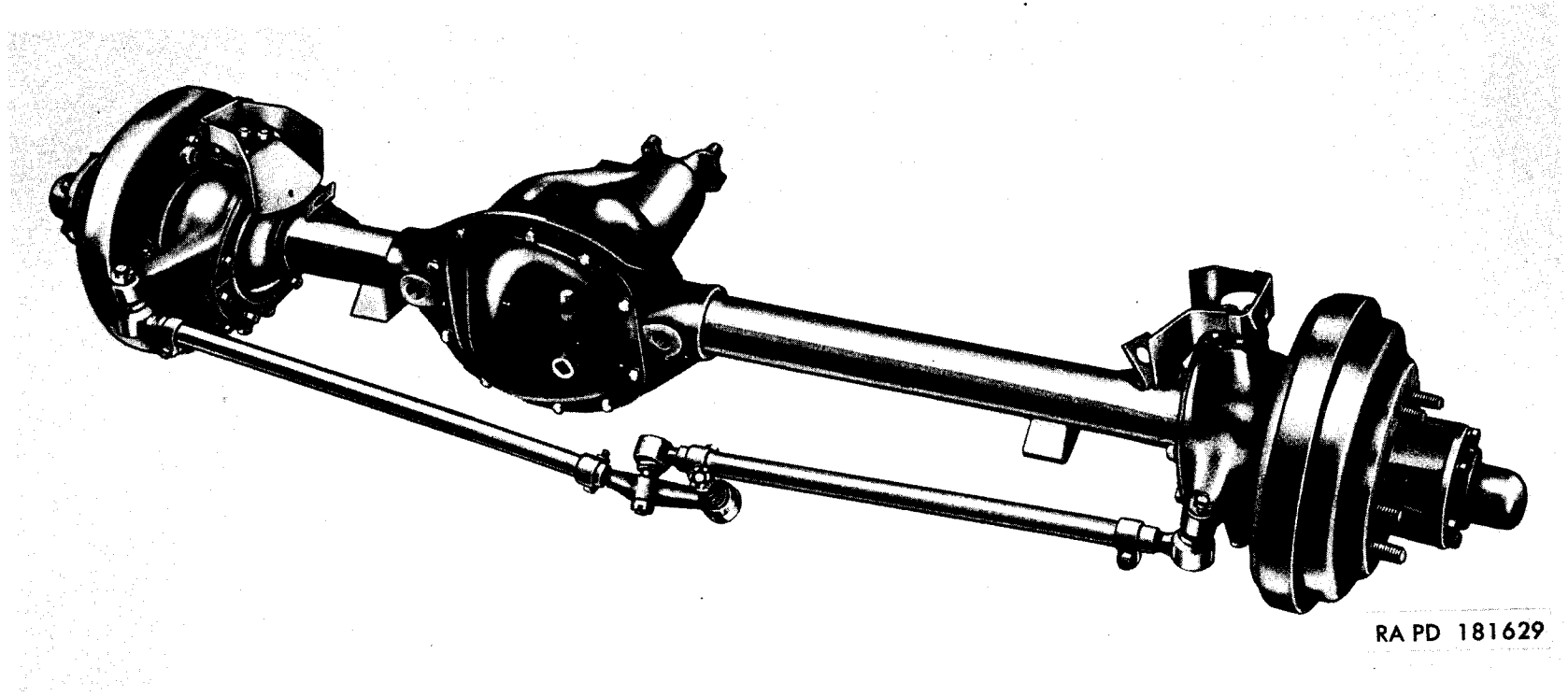

RA PD 181629

Figure 10-1. Front axle, assy (8329992)

| KEY | ITEM | PART NO | GROUP |
|-----|----------------|---------|--------|
| A | —SCREW | 120647 | 1004 |
| B | —NUT | 114494 | 1004 |
| C | —CAP | 7697606 | 1002 |
| D | —SCREW | 179890 | 1002 |
| E | —HOUSING, ASSY | 7348602 | 1001 |
| F | —VALVE, ASSY | 5196397 | 1005.5 |
| G | —PLUG | 113186 | 1001 |
| H | —BOLT | 187993 | 1001 |
| J | —COVER | 7372842 | 1001 |
| K | —GASKET | 7371103 | 1001 |

210

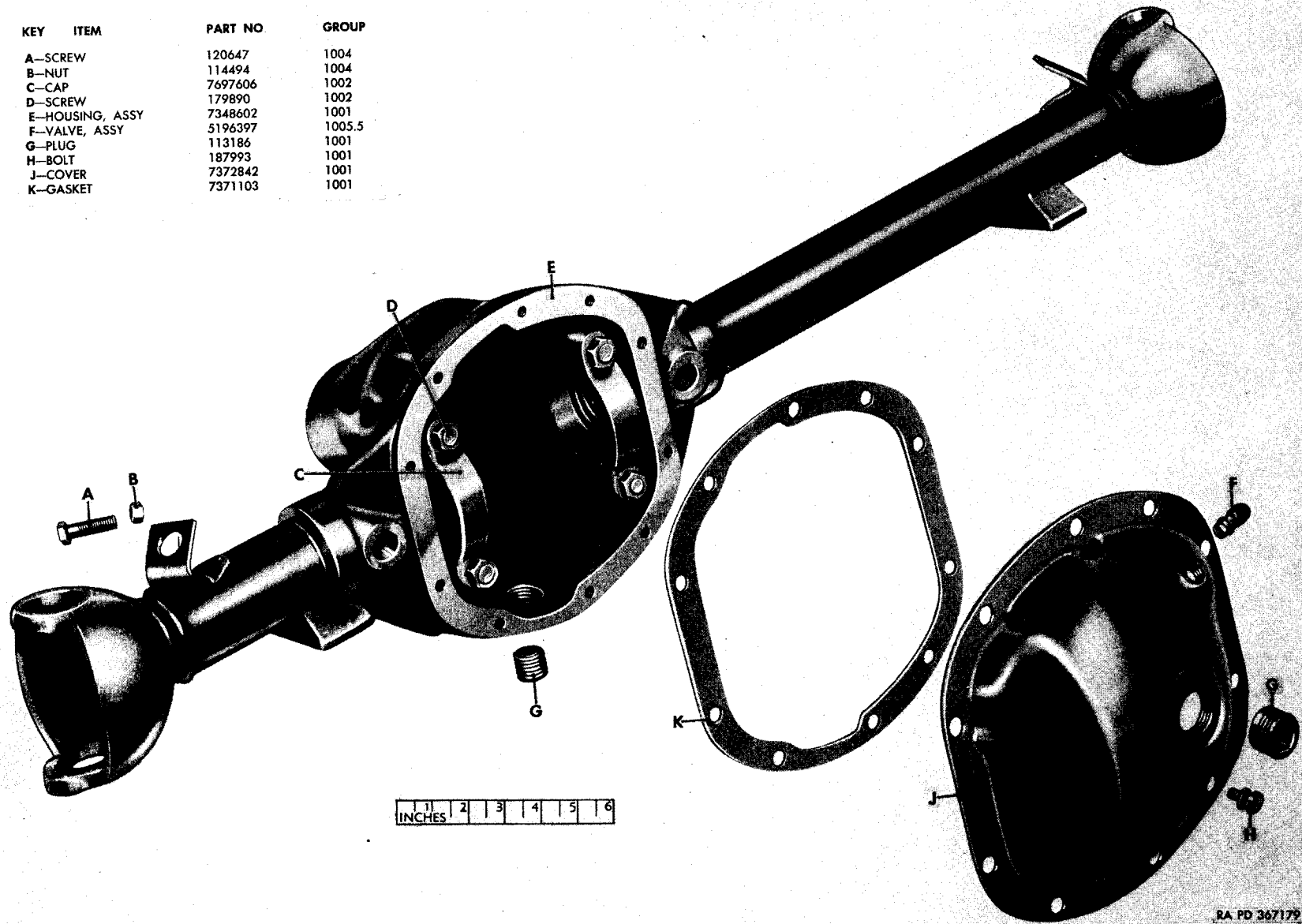

RA PD 367179

Figure 10-2. Front axle housing and related parts—exploded view

KEY ITEM

- A—GUIDE
- B—SEAL
- C—CUP
- D—CONE
- E—SHIM
- F—GEAR SET
- G—CONE
- H—CUP
- J—SHIM
- K—SHIM
- L—CUP
- M—CONE
- N—SLINGER
- P—GASKET
- Q—SEAL

PART NO.

- 7372869
- 500030
- 706849
- 705438
- 7372843
- 8677076
- 8329852
- 706877
- 7372847
- 7372850
- 707063
- 705271
- 7696512
- 7372855
- 500071

GROUP

- 1006
- 1006
- 1002
- 1002
- 1002
- 1002
- 1002
- 1002
- 1002
- 1002
- 1002
- 1002
- 1002
- 1002
- 1002

KEY ITEM

- R—YOKE, ASSY
- S—WASHER
- T—NUT
- U—WASHER
- V—WASHER
- W—GEAR SET
- X—PIN
- Y—SHAFT
- Z—PLATE
- AA—SCREW
- BB—CASE

PART NO.

- 7373121
- 221442
- 7032635
- 7371102
- 7373146
- 7372860
- 7372858
- 7372856
- 7372857
- 7372863
- 7372854

GROUP

- 1002
- 1002
- 1002
- 1002
- 1002
- 1002
- 1002
- 1002
- 1002
- 1002
- 1002

211

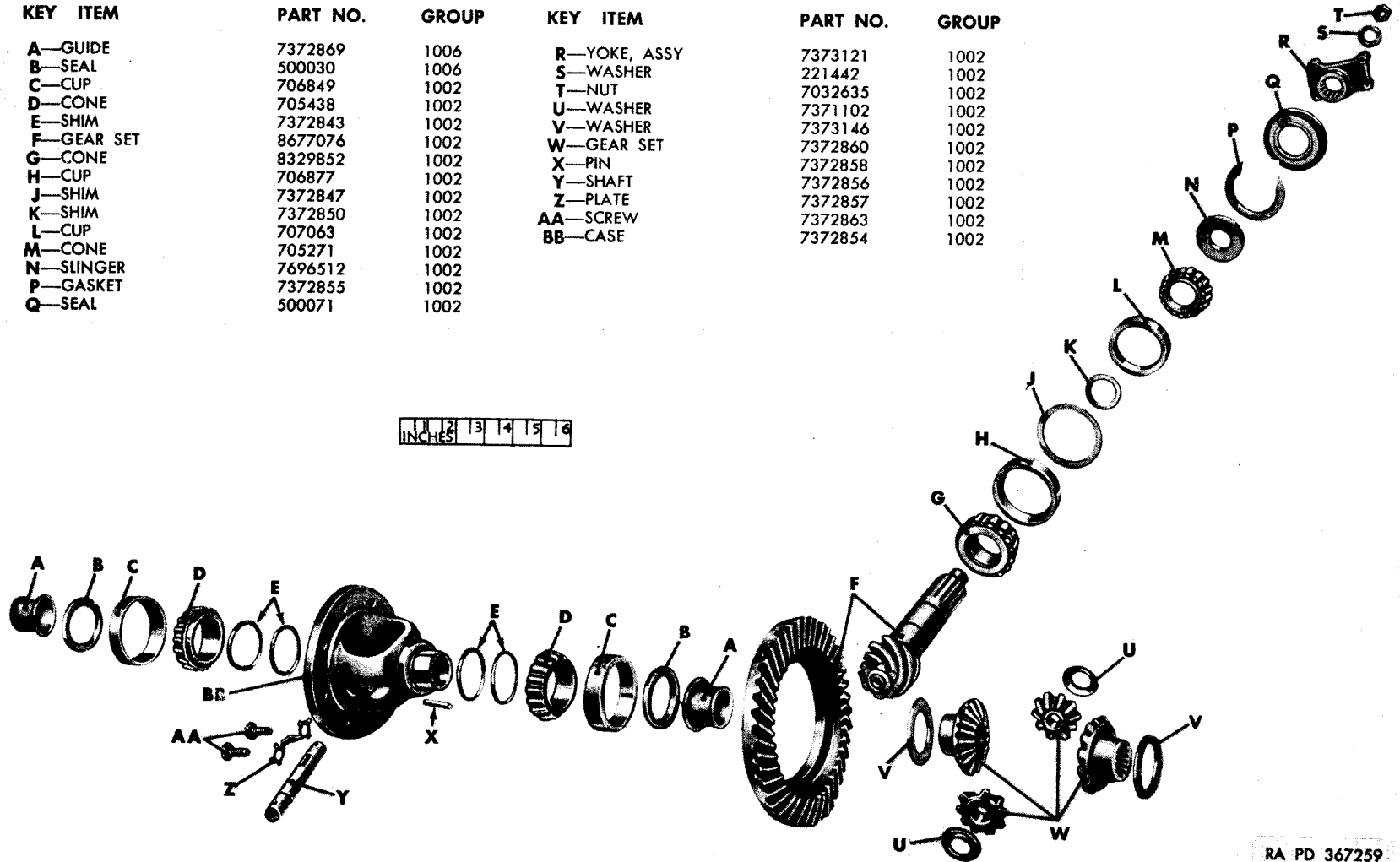

RA PD 367259

Figure 10-3. Front axle differential case and gears—exploded view

| KEY ITEM | PART NO. | GROUP | KEY ITEM | PART NO. | GROUP |
|-----------------------|----------|--------|------------|----------|-------|
| A—CAP | 7375143 | 1311 | T—CONE | 705381 | 1004 |
| B—FLANGE | 7371110 | 1006 | U—CUP | 706813 | 1004 |
| C—SHAFT | 7351403 | 1006 | V—WASHER | 7372870 | 1006 |
| D—SHAFT | 7351404 | 1006 | W—GASKET | 7696523 | 1004 |
| E—SHIM | 7371105 | 1004 | X—FLANGE | 8328398 | 1004 |
| F—CAP, ASSY | 7371108 | 1004 | Y—PLUG | 7372879 | 1004 |
| G—GUARD | 7032625 | 1204.5 | Z—BEARING | 7375045 | 1004 |
| H—WASHER | 120382 | 1004 | AA—SCREW | 100025 | 1004 |
| J—SCREW | 181645 | 1006 | BB—SPINDLE | 7994785 | 1004 |
| K—SCREW | 181643 | 1004 | CC—SEAL | 8329731 | 1311 |
| L—RETAINER | 7696526 | 1004 | DD—CONE | 705423 | 1311 |
| M—SPRING | 7032628 | 1004 | EE—CUP | 706836 | 1311 |
| N—SEAL | 7994778 | 1004 | FF—WASHER | 7696520 | 1311 |
| P—HOUSING, ASSY | 7348602 | 1001 | GG—NUT | 7371106 | 1311 |
| Q—NUT | 114494 | 1004 | HH—WASHER | 7696521 | 1311 |
| R—SCREW | 120647 | 1004 | JJ—GASKET | 7372872 | 1006 |
| S—SCREW, W/LOCKWASHER | 192417 | 1004 | KK—SCREW | 7372864 | 1006 |

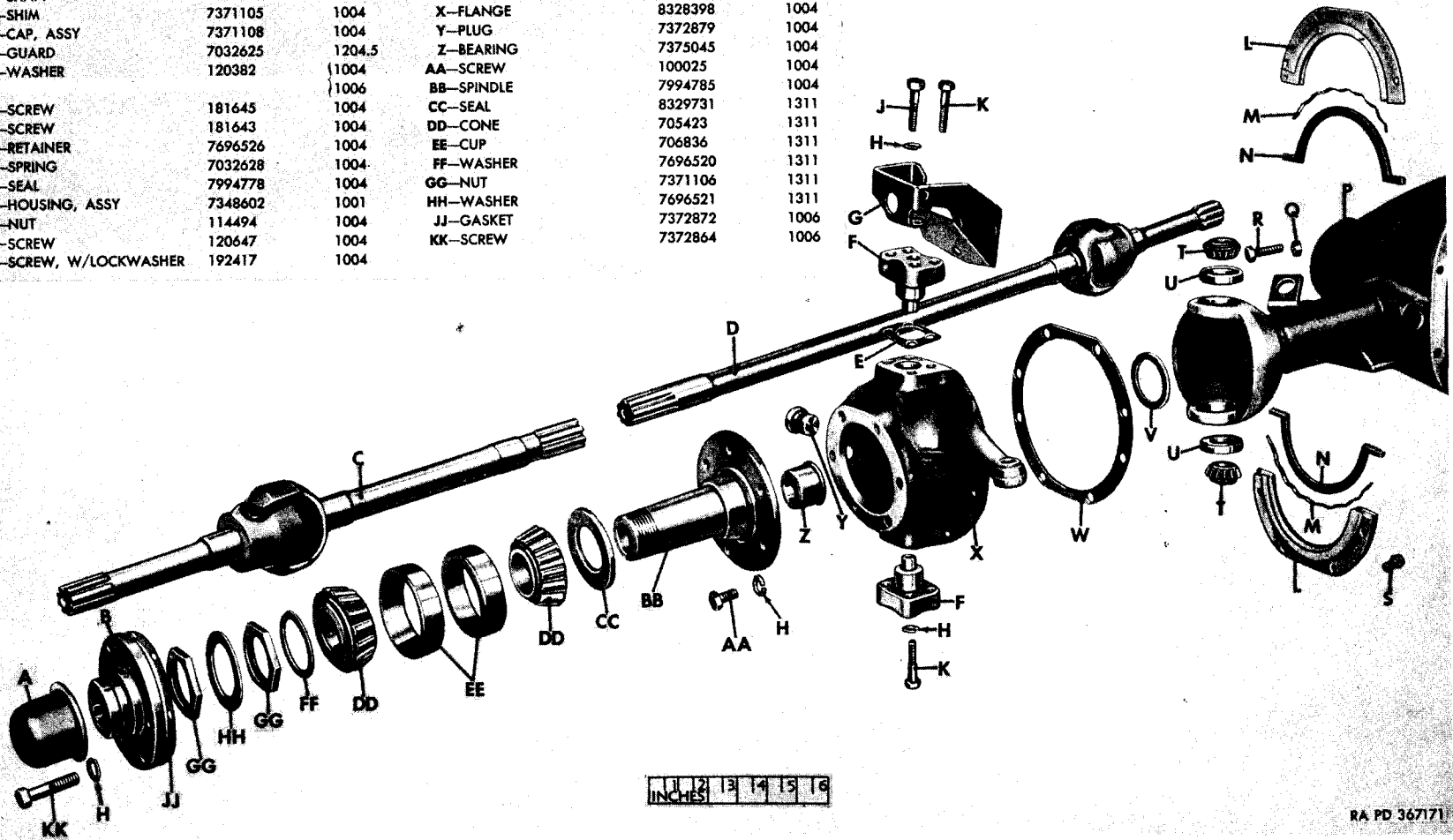

RA PD 367171

Figure 10-4. Steering knuckle and universal joint—exploded view

KEY ITEM

PART NO.

- A—SHAFT BX-60847
- B—PIN 7348763
- C—BALL 8679978
- D—BALL 7348759
- E—SHAFT 7348764
- F—PIN 7348762

NOTE: ALL PARTS LISTED ARE
IN GROUP 1006

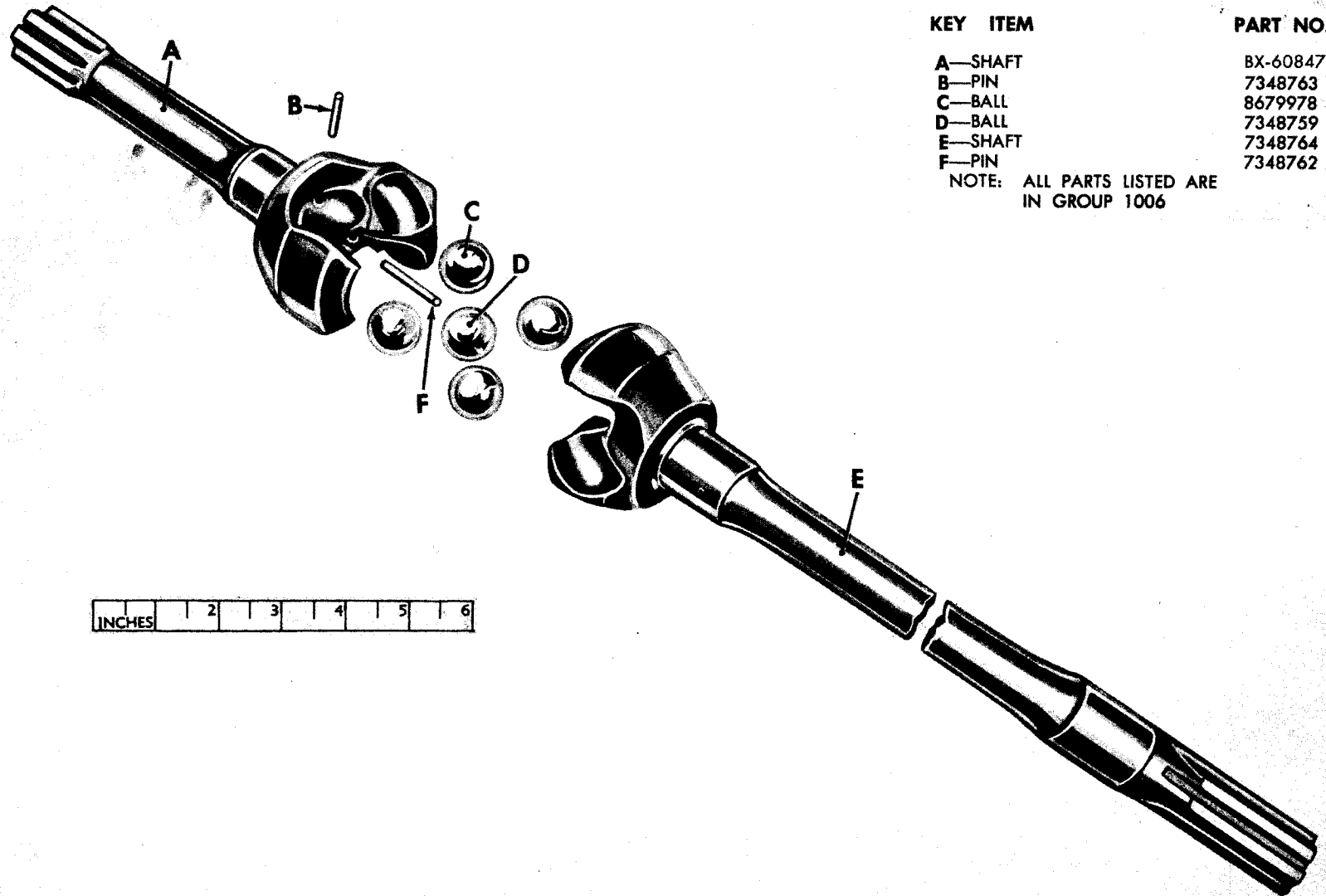

213

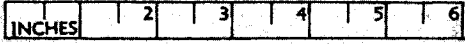

RA PD 367174

Figure 10-5. Front axle universal joint (Bendix)—exploded view

| KEY ITEM | PART NO | GROUP |
|----------|---------|-------|
| A—CAP | 7375143 | 1311 |
| B—SEAL | 8329732 | 1311 |
| C—RING | 583386 | 1006 |
| D—FLANGE | 7371110 | 1006 |
| E—GASKET | 7372872 | 1006 |
| F—NUT | 7371106 | 1311 |
| G—WASHER | 7696521 | 1311 |
| H—WASHER | 7696520 | 1311 |
| J—CUP | 706836 | 1311 |
| K—DRUM | 7328371 | 1311 |
| L—HUB | 7375142 | 1311 |

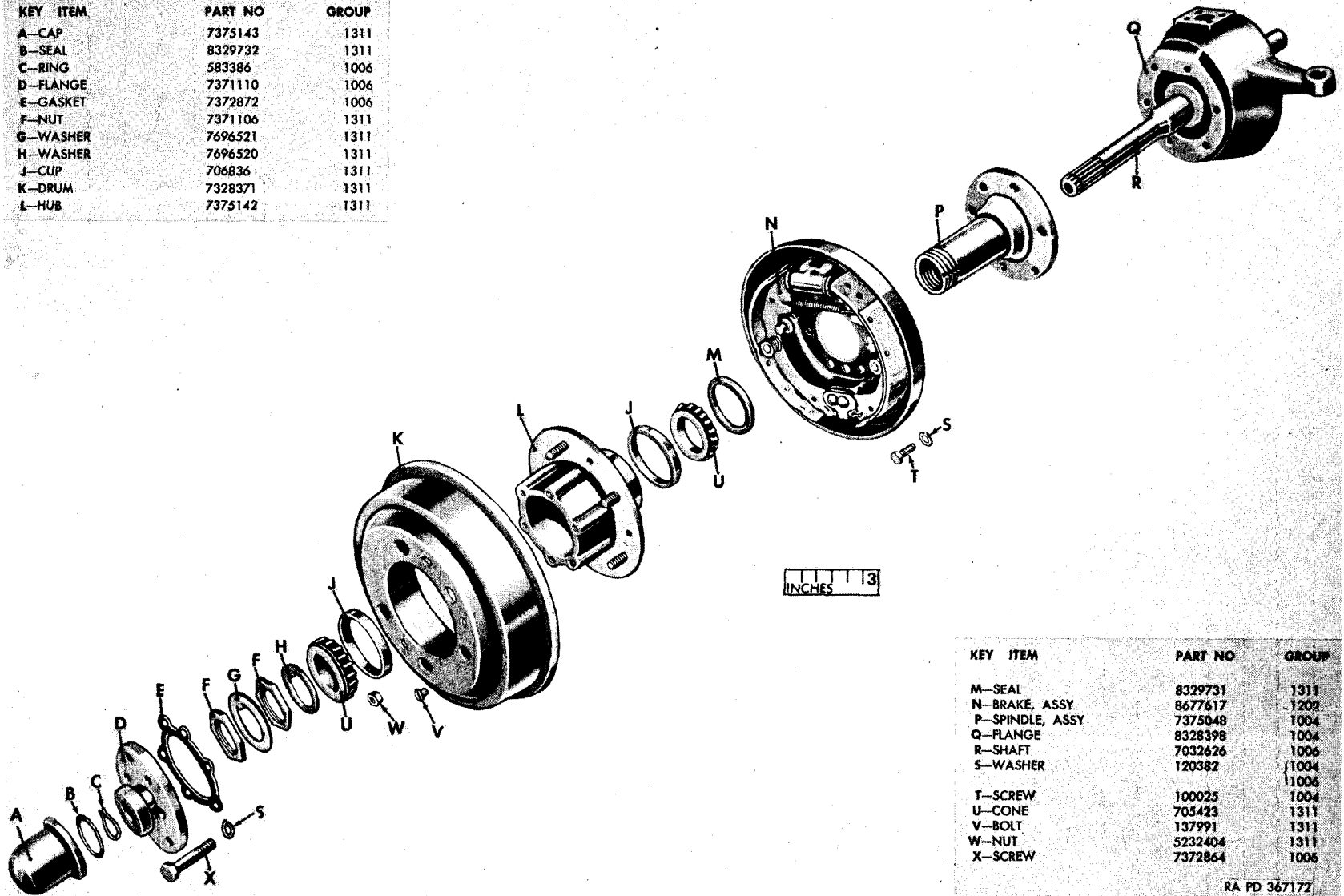

| KEY ITEM | PART NO | GROUP |
|-----------------|---------|-------|
| M—SEAL | 8329731 | 1311 |
| N—BRAKE, ASSY | 8677617 | 1202 |
| P—SPINDLE, ASSY | 7375048 | 1004 |
| Q—FLANGE | 8328398 | 1004 |
| R—SHAFT | 7032626 | 1006 |
| S—WASHER | 120382 | 1004 |
| T—SCREW | 100025 | 1004 |
| U—CONE | 705423 | 1311 |
| V—BOLT | 137991 | 1311 |
| W—NUT | 5232404 | 1311 |
| X—SCREW | 7372864 | 1006 |

RA PD 367172

Figure 10-6. Front wheel connecting parts—exploded view

| (1) ILLUSTRATION NO. | (2) REFER- ENCE SYMBOLS | (3) FEDERAL STOCK NO. | (4) ORDNANCE STOCK NO. | (5) MFR'S PART NO. | (6) ORDNANCE PART NO. | (7) DESCRIPTION | (8) QUANTITY INCOR- PORATED IN UNIT | (9) UNIT OF ISSUE |
|--------------------------------------|----------------------------------|-----------------------------|------------------------------|------------------------|-----------------------------|--|---|----------------------------|
| GROUP 10—FRONT AXLE | | | | | | | | |
| 1000—FRONT AXLE ASSEMBLY | | | | | | | | |
| 10-1 | | | | SP-2166-1 WO-805788 | | AXLE, front, assy (Bendix joints)..... | 1 | ea |
| | | | | SP-2166-2 WO-805789 | | AXLE, front, assy (Rzeppa joints)..... | 1 | ea |
| | | | G758-8329992 | WO-807872 | 8329992 | AXLE, front, w/BRAKES, HUB, and BRAKE DRUM, assy | 1 | ea |
| | | | | WO-807873 | 8673520 | AXLE, front (w/BRAKES, HUB, and BRAKE DRUM, assy) (Bendix or Rzeppa joints) | 1 | ea |
| 1001—HOUSING, COVER AND PLUGS | | | | | | | | |
| 10-2 | | 2520-737-2842 | G740-7372842 | SP-17434 WO-A10231 | 7372842 | COVER, gear carrier housing..... | 1 | ea |
| 10-2 | H1 | 018-7993 | H101-0187993 | | 187993 | BOLT, ext-teeth-lock washer, hex-hd, S, cd- or zn- pltd, 5/16-18NC-2 x 3/4 | 10 | ea |
| 10-2 | | 2530-495-7074 | G503-7371103 | SP-16409 WO-A782 | 7371103 | GASKET, housing cover..... | 1 | ea |
| 10-2, 4 | | 2520-734-8602 | G740-7348602 | SP-18596X WO-802300 | 7348602 | HOUSING, gear carrier, w/TUBE, assy..... | 1 | ea |
| 10-2 | H6 | | H006-0283765 | | 113186 | PLUG, pipe, sq-socket, hds, MI, 1/4 in. (drain and filler)... | 2 | ea |
| 1002—DIFFERENTIAL | | | | | | | | |
| 10-2 | | 2520-769-7606 | G740-7697606 | SP-16379 WO-A764 | 7697606 | CAP, case bearing..... | 2 | ea |
| 10-2 | H1 | 017-9890 | H101-0179890 | | 179890 | SCREW, cap, hex-hd, S, 85,000 psi yield strength, 1/2-13NC-3 x 2 1/4 | 4 | ea |
| 10-3 | | 2520-737-2854 | G740-7372854 | SP-16383 WO-A793 | 7372854 | CASE..... | 1 | ea |
| 10-3 | H12 | | H012-6146900 | | 705438 | CONE, tapered roller bearing, MIL-STD-CODE 711- 24780-3000 (includes roller and cage, SR, 1.6250 bore, 0.9063 width) (case bearing) | 2 | ea |
| 10-3 | H12 | | H012-6122200 | | 705271 | CONE, tapered roller bearing, MIL-STD-CODE 719- 02872-3000 (includes rollers and cage, SR, 1.1250 bore, 0.8750 width) (drive pinion outer bearing) | 1 | ea |
| 10-3 | H12 | | H012-8329852 | | 8329852 | CONE, tapered roller bearing (includes rollers and cage, SR, 1.3750 bore, 1.1250 width) (drive pinion inner bearing) | 1 | ea |

| (1) ILLUSTRATION NO. | (2) REFER- ENCE SYMBOLS | (3) FEDERAL STOCK NO. | (4) ORDNANCE STOCK NO. | (5) MFR'S PART NO. | (6) ORDNANCE PART NO. | (7) DESCRIPTION | (8) QUANTITY INCOR- PORATED IN UNIT | (9) UNIT OF ISSUE |
|--------------------------------------|----------------------------------|-----------------------------|------------------------------|--------------------------|-----------------------------|---|---|----------------------------|
| GROUP 10—FRONT AXLE—Continued | | | | | | | | |
| 1002—DIFFERENTIAL—Continued | | | | | | | | |
| 10-3 | H12 | | H012-6209700 | | 707063 | CUP, tapered roller bearing, MIL-STD-CODE 719-02820-1000 (SR, 2.8750 OD, 0.6875 width) (drive pinion outer bearing) | 1 | ea |
| 10-3 | H12 | | H012-6220960 | | 706849 | CUP, tapered roller bearing, MIL-STD-CODE 711-24721-1000 (SR, 3.0000 OD, 0.8125 width) (case bearing) | 2 | ea |
| 10-3 | H12 | | H012-6224700 | | 706877 | CUP, tapered roller bearing, MIL-STD-CODE 711-31520-1000 (SR, 3.0000 OD, 0.9375 width) (drive pinion inner bearing) | 1 | ea |
| | | 2520-734-8603 | G740-7348603 | SP-18397-6X WO-801929 | 7348603 | DIFFERENTIAL, front axle, assy..... | 1 | ea |
| 10-3 | | 2530-737-2855 | G740-7372855 | SP-30188 WO-636565 | 7372855 | GASKET, paper, 2 $\frac{3}{4}$ ID, 3 $\frac{3}{4}$ OD, 0.040 thk (drive pinion oil seal) | 1 | ea |
| | | | | SP-17555 WO-644141 | 8677287 | GEAR, bevel side..... | 2 | ea |
| | | | | SP-17483 WO-640699 | 8677013 | GEAR, hypoid bevel drive, 43T..... | 1 | ea |
| 10-3 | | 2520-737-2860 | G740-7372860 | SP-17797 WO-644148 | 7372860 | GEAR SET, side, w/PINION..... | 1 | ea |
| | | | | | 8677287 | Composed of: | | |
| | | | | | 8677288 | 2 GEAR | | |
| | | | | | 8677076 | 2 PINION | | |
| 10-3 | | | | SP-18392X WO-801926 | | GEAR SET, w/PINION and NUT..... | 1 | ea |
| 10-3 | | 5315-737-2858 | G740-7372858 | SP-13449 WO-636360 | 7372858 | PIN, STRAIGHT, HEADLESS, locking, pinion shaft..... | 1 | ea |
| | | | | SP-17556 WO-644142 | 8677288 | PINION, bevel side gear..... | 2 | ea |
| | | | | SP-18396 WO-801927 | 8673464 | PINION, hypoid bevel, 8T (drive)..... | 1 | ea |
| 10-3 | | 2530-737-2857 | G740-7372857 | SP-16866 WO-A792 | 7372857 | PLATE, locking, axle drive gear screw..... | 4 | ea |
| 10-3 | | 5305-737-2863 | G740-7372863 | SP-3Q187 WO-649454 | 7372863 | SCREW, hex-hd, $\frac{3}{8}$ -24NF-3 x 1 $\frac{5}{16}$ (axle drive gear)..... | 8 | ea |
| 10-3 | H13 | | H013-0500071 | | 500071 | SEAL, oil, type MLS, 1 $\frac{1}{16}$ x 3.165 x 1 $\frac{9}{32}$ (drive pinion)..... | 1 | ea |
| 10-3 | | 2520-737-2856 | G740-7372856 | SP-16075 WO-A798 | 7372856 | SHAFT, bevel pinion mate..... | 1 | ea |

| | | | | | | | | |
|------|----|---------------|--------------|-------------------------|---------|--|---|----|
| | | 2520-495-7068 | G740-7372859 | SP-15099 WO-636568 | 7372859 | SHIELD, dust, drive pinion..... | 1 | ea |
| 10-3 | | | G740-7372843 | SP-S58 WO-639959 | 7372843 | SHIM, case bearing..... | ‡ | ea |
| | | | G740-7372844 | SP-S59 WO-639960 | 7372844 | 0.003 thk | | |
| | | | G740-7372845 | SP-S74 WO-639961 | 7372845 | 0.005 thk | | |
| | | | G740-7372846 | SP-S75 WO-639962 | 7372846 | 0.010 thk | | |
| 10-3 | | | | | | SHIM, drive pinion inner bearing..... | ‡ | ea |
| | | | G740-7372847 | SP-S112 WO-639969 | 7372847 | 0.003 thk | | |
| | | | G740-7372848 | SP-S113 WO-639970 | 7372848 | 0.005 thk | | |
| | | | G740-7372849 | SP-S114 WO-639971 | 7372849 | 0.030 thk | | |
| 10-3 | | | | | | SHIM, drive pinion outer bearing..... | ‡ | ea |
| | | | G740-7372850 | SP-S638 WO-639972 | 7372850 | 0.003 thk | | |
| | | | G740-7372851 | SP-S638-1 WO-639973 | 7372851 | 0.005 thk | | |
| | | | G740-7372852 | SP-S638-2 WO-639974 | 7372852 | 0.010 thk | | |
| | | | G740-7372853 | SP-S638-3 WO-639975 | 7372853 | 0.030 thk | | |
| 10-3 | | 2520-769-6512 | G503-7696512 | SP-13575 WO-636566 | 7696512 | SLINGER, oil, drive pinion bearing..... | 1 | ea |
| 10-3 | | 5310-270-8840 | G503-7373146 | SP-16323-4 WO-A795 | 7373146 | WASHER, thrust (side gear)..... | 2 | ea |
| 10-3 | H1 | 5310-022-1442 | H001-7036380 | | 221442 | WASHER, plain, S, $\frac{3}{8}$ ID, $1\frac{1}{2}$ OD, 0.1196 thk (drive pinion nut) | 1 | ea |
| 10-3 | | 3120-737-1102 | G503-7371102 | SP-16322-4 WO-A797 | 7371102 | WASHER, thrust, pinion..... | 2 | ea |
| | | 2520-734-8604 | G740-7348604 | SP-2-4-581 WO-A1446 | 7348604 | YOKE, propeller shaft to axle..... | 1 | ea |
| | | | G758-8328414 | WO-807694 | 8328414 | YOKE, end, w/SHIELD, assy (superseded by YOKE 7373121) | 1 | ea |
| 10-3 | | 2520-495-7112 | G503-7373121 | SP-2-4-108X WO-A1445 | 7373121 | YOKE, end, w/SHIELD, assy (supersedes YOKE 8328414) | 1 | ea |
| 10-3 | H1 | | H101-7032635 | | 7032635 | NUT, hex, "Huglock" type, $\frac{3}{4}$ -16NF-2 (pinion)..... | 1 | ea |

| (1) ILLUSTRATION NO. | (2) REFERENCE SYMBOLS | (3) FEDERAL STOCK NO. | (4) ORDNANCE STOCK NO. | (5) MFR'S PART NO. | (6) ORDNANCE PART NO. | (7) DESCRIPTION | (8) QUANTITY INCORPORATED IN UNIT | (9) UNIT OF ISSUE |
|--------------------------------------|--------------------------|--------------------------|---------------------------|-------------------------|--------------------------|---|--------------------------------------|----------------------|
| GROUP 10—FRONT AXLE—Continued | | | | | | | | |
| 1004—STEERING KNUCKLES | | | | | | | | |
| 10-4 | | 3120-737-5045 | G740-7375045 | SP-18174 WO-649783 | 7375045 | BEARING, bushing type, wheel bearing spindle..... | 2 | ea |
| | | 5305-456-6211 | G503-7373188 | SP-6-73-1117 WO-A821 | 7373188 | BOLT, MACHINE, knuckle adj, S, 3/8-24NF-3 x 1 1/8..... | 2 | ea |
| 10-2, 4 | H1 | 5310-011-4494 | H001-4185600 | | 114494 | NUT, jam, hex, lt, s-fin, S, 3/8-24NF-2..... | 2 | ea |
| | | | | SP-16995 WO-A829 | | CAP, king pin bearing (steering knuckle)..... | 4 | ea |
| 10-4 | | 2530-737-1108 | G503-7371108 | SP-17048X WO-A828 | 7371108 | CAP, steering knuckle, w/king PIN and locking PIN, assy | 4 | ea |
| | | | | SP-16995 | | Composed of: | | |
| | | | | | 7696518 | 1 CAP | | |
| | | | | | 7696482 | 1 PIN | | |
| | | | | | 181643 | 1 PIN | | |
| 10-4 | H1 | 018-1643 | H001-5455341 | | 181643 | SCREW, cap, hex-hd, S, 85,000 psi yield strength, cd- or zn-pltd, 3/8-24NF-3 x 1 1/2 | 12 | ea |
| 10-4 | H1 | 018-1645 | H001-5455381 | | 181645 | SCREW, cap, hex-hd, S, 85,000 psi yield strength, cd- or zn-pltd, S, 3/8-24NF-3 x 1 3/8 | 4 | ea |
| 10-4, 6 | H1 | 5310-012-0382 | H001-7025741 | | 120382 | WASHER, lock, med, S, cd- or zn-pltd, 3/8 in..... | 16 | ea |
| 10-4 | H12 | | H012-6133330 | | 705331 | CONE, tapered roller bearing, MIL-STD-CODE 711- 11390-3000 (includes rollers and cage, SR, steep angle, 0.6250 bore, 0.5265 width) (king pin bearing) | 4 | ea |
| 10-4 | H12 | | H012-6216140 | | 706813 | CUP, tapered roller bearing, MIL-STD-CODE 711- 11520-1000 (SR, steep angle, 1.6875 OD, 0.3750 width) (king pin bearing) | 4 | ea |
| | | | G758-8328397 | SP-30071 WO-805783 | 8328397 | FLANGE, steering, left, w/integral ARM..... | 1 | ea |
| 10-4, 6 | | | G758-8328398 | SP-30070 WO-805784 | 8328398 | FLANGE, steering, right, w/integral ARM..... | 1 | ea |
| 10-4 | | 2520-769-6523 | G503-7696523 | SP-17041 WO-A820 | 7696523 | GASKET, steering knuckle oil seal..... | 2 | ea |
| | | 2530-769-6518 | G503-7696518 | SP-16991 WO-A824 | 7696518 | PIN, king..... | 4 | ea |
| | | 5315-769-6482 | G503-7696482 | SP-8957 WO-A825 | 7696482 | PIN, STRAIGHT, HEADLESS, locking, king pin..... | 4 | ea |
| 10-4 | | 4730-737-2879 | G740-7372879 | SP-18-39-3 WO-801660 | 7372879 | PLUG, PIPE, spec, ck-hd, MI, 1/2 in. (filler, steering knuckle) | 2 | ea |
| 10-4 | | 2530-769-6526 | G503-7696526 | SP-17133X WO-A814 | 7696526 | RETAINER, steering knuckle oil, half seal..... | 4 | ea |

| | | | | | | | | |
|--|-----|---------------|--------------|------------------------|---------|--|----|----|
| 10-4 | | | G740-7994778 | SP-18593 WO-800095 | 7994778 | SEAL (half) oil, steering knuckle (ru)..... | 4 | ea |
| | | | G740-7375049 | SP-18592X WO-801759 | 7375049 | SEAL (half) oil, steering knuckle, assy..... | 4 | ea |
| | | 5305-734-8605 | G740-7348605 | SP-S1640 WO-802498 | 7348605 | BOLT, INTEGRAL LOCK WASHER, ext-teeth-lock washer, hex-hd, S, cd-pltd, $\frac{5}{16}$ -24NF-3 x $1\frac{1}{16}$ (super- seded by SCREW 192417) | 16 | ea |
| 10-4 | H1 | | H101-0192417 | | 192417 | SCREW, ext-teeth-lock washer, hex-hd, S, cd- or zn- pltd, $\frac{5}{16}$ -24NF-2 x $\frac{3}{4}$ (supersedes BOLT 7348605) | 16 | ea |
| 10-2, 4 | H1 | | H001-5421261 | | 120647 | SCREW, CAP, hex-hd, S, cd- or zn-pltd, $\frac{3}{8}$ -24NF-3 x 1 (supersedes BOLT, 7313188) | 2 | ea |
| 10-4 | | | G503-7371105 | SP-16992-2 WO-A831 | 7371105 | SHIM, king pin bearing, 0.005 thk | † | ea |
| | | | G503-7520991 | SP-16992-3 WO-A832 | 7520991 | 0.010 thk | | |
| | | | G503-7373148 | SP-16992-4 WO-A833 | 7373148 | 0.030 thk | | |
| 10-4 | | | | SP-16964 WO-A852 | 7994785 | SPINDLE, wheel bearing..... | 2 | ea |
| 10-6 | | 2530-737-5048 | G740-7375048 | SP-18173X WO-649782 | 7375048 | SPINDLE, wheel bearing, w/BEARING, assy..... | 2 | ea |
| 10-4, 6 | H1 | 010-0025 | H001-5421220 | | 100025 | SCREW, hex-hd, S, $\frac{3}{8}$ -24NF-2 x $\frac{3}{4}$ | 12 | ea |
| 10-4, 6 | H1 | 5310-012-0382 | H001-7025741 | | 120382 | WASHER, lock, med, S, cd- or zn-pltd, $\frac{3}{8}$ in..... | 12 | ea |
| 10-4 | | 5340-703-2628 | G740-7032628 | SP-18594 WO-800068 | 7032628 | SPRING, steering knuckle oil seal..... | 4 | ea |
| 1005.5-VENTILATION | | | | | | | | |
| 10-2 | H16 | | H016-5196397 | | 5196397 | VALVE, air, assy..... | 1 | ea |
| 1006-SHAFT AND UNIVERSAL JOINTS | | | | | | | | |
| 10-5 | | | | BX-60572 WO-A6289 | 8679978 | BALL, alloy-S (universal joint, outer) (Bendix joint), 0.872 dia | † | ea |
| | | | G740-7348767 | BX-60573 WO-A6290 | 7348767 | 0.873 dia | | |
| | | | G503-7416485 | BX-60574 WO-A6291 | 7416485 | 0.874 dia | | |
| | H2 | | H102-0145652 | | 145652 | 0.875 dia | | |
| | | | G503-7416486 | BX-60576 WO-A6293 | 7416486 | 0.876 dia | | |
| | | | G740-7348768 | BX-60577 WO-A6294 | 7348768 | 0.877 dia | | |
| | | | | BX-60578 WO-A6295 | | 0.878 dia | | |

| (1) ILLUSTRATION NO. | (2) REFERENCE SYMBOLS | (3) FEDERAL STOCK NO. | (4) ORDNANCE STOCK NO. | (5) MFR'S PART NO. | (6) ORDNANCE PART NO. | (7) DESCRIPTION | (8) QUANTITY INCORPORATED IN UNIT | (9) UNIT OF ISSUE |
|--|--------------------------|--------------------------|---------------------------|--|--------------------------|--|--------------------------------------|----------------------|
| GROUP 10—FRONT AXLE—Continued | | | | | | | | |
| 1006—SHAFT AND UNIVERSAL JOINTS—Continued | | | | | | | | |
| 10-5 | | 2520-734-8759 | G740-7348759 | BX-60368 WO-A6288 | 7348759 | BALL, universal joint (center, drilled) (Bendix joint)..... | 2 | ea |
| | | 2520-737-3108 | G503-7373108 | SP-17232 WO-A1721 | 7373108 | BALL, universal joint (S, 1 $\frac{1}{8}$ dia) (Rzeppa joint)..... | 12 | ea |
| | | 2520-754-0093 | G503-7540093 | SP-17230 WO-A1719 | 7540093 | CAGE, universal joint (Rzeppa)..... | 2 | ea |
| 10-4, 6 | | 2520-737-1110 | G503-7371110 | SP-17153 WO-A868 | 7371110 | FLANGE, drive, axle shaft..... | 2 | ea |
| 10-4, 6 | | 5305-737-2864 | G740-7372864 | SP-6-73-124 WO-A760 | 7372864 | SCREW, hex-hd, s-fin, alloy-S, $\frac{3}{8}$ -16NC-2 x 1 $\frac{1}{2}$ | 12 | ea |
| 10-4, 6 | H1 | 5310-012-0382 | H001-7025741 | | 120382 | WASHER, lock, med, S, cd- or zn-pltd, $\frac{3}{8}$ in..... | 12 | ea |
| 10-4, 6 | | 2520-737-2872 | G740-7372872 | SP-18188 WO-649784 | 7372872 | GASKET, drive flange, axle shaft..... | 2 | ea |
| 10-3 | | 2530-495-7087 | G740-7372869 | SP-17377 WO-A6439 | 7372869 | GUIDE, axle shaft..... | 2 | ea |
| 10-5 | | 5315-734-8762 | G740-7348762 | BX-60364 WO-A6279 | 7348762 | PIN, universal joint center ball (Bendix joint)..... | 2 | ea |
| 10-5 | | 5315-734-8763 | G740-7348763 | BX-60409 WO-A6278 RZ-OR33-6 WO-802314 | 7348763 8677079 | PIN, GROOVED, HEADLESS, universal joint groove (Bendix joint) | 2 | ea |
| | | | | SP-30103 WO-810086 | | RACE, universal joint, inner (Rzeppa) (used on vehicles equipped w/SHAFT 8673512 and SHAFT SP-18597-1X) | 2 | ea |
| | | 2530-754-0096 | G503-7540096 | SP-17216 WO-A1724 | 7540096 | RETAINER, universal joint inner shaft (Rzeppa joint) (used on vehicles equipped w/SHAFT 8673512 and SHAFT SP-18597-1X) | 2 | ea |
| | H1 | 5305-013-3503 | H101-0133503 | | 133503 | SCREW, mach, fl-hd, S, cd- or zn-pltd, no. 8 (0.164)-32NC-2 x $\frac{1}{8}$ | 6 | ea |
| 10-6 | H2 | | H002-0583386 | | 583386 | RING, snap, retaining, exter, S, cd- or zn-pltd, 1 $\frac{1}{8}$ in. shaft dia (outer axle shaft) (Rzeppa joint) | 2 | ea |
| | | 5340-737-2865 | G740-7372865 | SP-17218 WO-A1726 | 7372865 | RING, snap, wire, S, plain, 1 $\frac{1}{8}$ ID, 0.065 thk (inner shaft) (Rzeppa joint) (used on vehicles equipped w/SHAFT 8673512 and SHAFT SP-18597-1X) | 2 | ea |
| | | | | SP-30101 WO-810095 | | RING, spec, snap, retn, exter, S, 1.016 in. shaft dia (inner shaft) (Rzeppa) (used on vehicles equipped w/SHAFT SP-20128-2X and SHAFT SP-20128-1X) | 2 | ea |

Z1

| | | | | | | | | |
|------|-----|---------------|--------------|---------------------------------------|--------------------|---|---|----|
| 10-3 | H13 | | H013-0500030 | | 500030 | SEAL, oil, type MW, 1 $\frac{3}{16}$ x 2.004 x $\frac{1}{4}$ (axle shaft, inner). | 2 | ea |
| 10-4 | | 2520-735-1404 | G740-7351404 | BX-60771 SP-18172-2X WO-649771 | 7351404 | SHAFT, complete, left, w/universal JOINT, assy (Bendix) | 1 | ea |
| | | | | SP-18597-2X RZ-VA2558 WO-802315 | 8673512 | SHAFT, complete, left, w/universal JOINT, assy (Rzeppa) (interchangeable, w/SHAFT SP-20128-2X) | 1 | ea |
| 10-4 | | 2520-735-1403 | G740-7351403 | SP-20128-2X WO-810081 | | SHAFT, complete, left, w/universal JOINT, assy (Rzeppa) (interchangeable, w/SHAFT 8673512) | 1 | ea |
| | | | | BX-60772 SP-18172-1X WO-649772 | 7351403 | SHAFT, complete, right, w/universal JOINT, assy (Bendix) | 1 | ea |
| | | | | SP-18597-1X WO-802316 | | SHAFT, complete, right, w/universal JOINT, assy (Rzeppa) (interchangeable, w/SHAFT SP-20128-1X) | 1 | ea |
| 10-5 | | 2520-734-8764 | G740-7348764 | SP-20128-1X WO-810082 | | SHAFT, complete, right, w/universal JOINT, assy (Rzeppa) (interchangeable, w/SHAFT SP-18597-1X) | 1 | ea |
| | | | | BX-60524 WO-A6276 | 7348764 | SHAFT, inner, left (Bendix joint) | 1 | ea |
| | | 2530-737-2866 | G740-7372866 | SP-17122-4 WO-A1729 | 7372866 | SHAFT, inner, left (Rzeppa) (used on vehicles equipped w/SHAFT 8673512) | 1 | ea |
| | | | | SP-30102-2 WO-810091 | | SHAFT, inner, left (Rzeppa) (used on vehicles equipped w/SHAFT SP-20128-2X) | 1 | ea |
| | | 2520-734-8765 | G740-7348765 | BX-60525 WO-A6277 | 7348765 | SHAFT, inner, right (Bendix joint) | 1 | ea |
| | | 2530-737-2867 | G740-7372867 | SP-17122-3 WO-A1727 | 7372867 | SHAFT, inner, right (Rzeppa) (used on vehicles equipped w/SHAFT SP-18597-1X) | 1 | ea |
| | | | | SP-30102-1 WO-810092 | | SHAFT, inner, right (Rzeppa) (used on vehicles equipped w/SHAFT SP-20128-1X) | 1 | ea |
| | | 2520-734-8766 | G740-7348766 | WO-649770 | 7348766 | SHAFT, outer (Bendix joint) (superseded by SHAFT BX-60847) | 2 | ea |
| 10-5 | | | | BX-60847 WO-906703 | | SHAFT, outer (Bendix joint) (supersedes SHAFT 7348766) | 2 | ea |
| 10-6 | | 2520-703-2626 | G740-7032626 | SP-30020 WO-802321 WO-810085 | 7032626 | SHAFT, outer (Rzeppa) | 2 | ea |
| | | | | | | SHAFT, outer, w/universal JOINT, assy (Rzeppa) (used on vehicles equipped, w/SHAFT SP-20128-2X and SHAFT SP-20128-1X) | 2 | ea |
| | | | | | 7373108 7540092 | Composed of: 6 BALL 1 CAGE 1 RACE | | |
| | | | | SP-30103 WO-810086 | 7032626 | 1 SHAFT | | |

1006

1005

222

| (1) ILLUSTRATION NO. | (2) REFER- ENCE SYMBOLS | (3) FEDERAL STOCK NO. | (4) ORDNANCE STOCK NO. | (5) MFR'S PART NO. | (6) ORDNANCE PART NO. | (7) DESCRIPTION | (8) QUANTITY INCOR- PORATED IN UNIT | (9) UNIT OF ISSUE |
|-------------------------|----------------------------------|-----------------------------|------------------------------|------------------------|---|--|---|----------------------------|
| | | 2520-734-7733 | G740-7347733 | SP-20017X WO-802319 | 7347733 | GROUP 10—FRONT AXLE—Continued 1006—SHAFT AND UNIVERSAL JOINTS—Continued SHAFT, outer, w/universal JOINT, assy (Rzeppa) (used on vehicles equipped, w/SHAFT SP-18597-1X and SHAFT 8673512) (supersedes SHAFT 8677080) Composed of: 1 RETAINER 1 RING 3 SCREW 1 SHAFT | 1 | ea |
| | | | | SP-20047X WO-802320 | 8677080 | SHAFT, outer, w/universal JOINT, sub-assy (Rzeppa) (for service use SHAFT SP-20017X) (used on vehicles equipped w/SHAFT SP-18597-1X and SHAFT 8673512) (superseded by SHAFT 7347733) Composed of: 6 BALL 1 CAGE 1 RACE 1 SHAFT | 2 | ea |
| 10-4 | | 3120-737-2870 | G740-7372870 | SP-S1622 WO-649769 | 7373108 7540093 8677079 7032626 7372870 | WASHER, thrust, universal joint..... | 2 | ea |

223

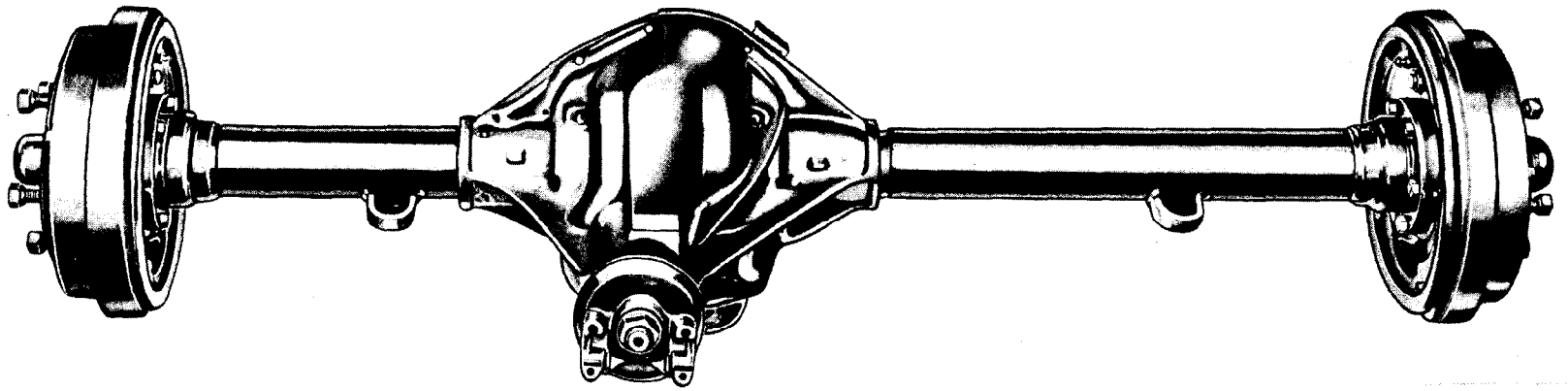

RA PD 181628

Figure 11-1. Rear axle, assy (8929854)

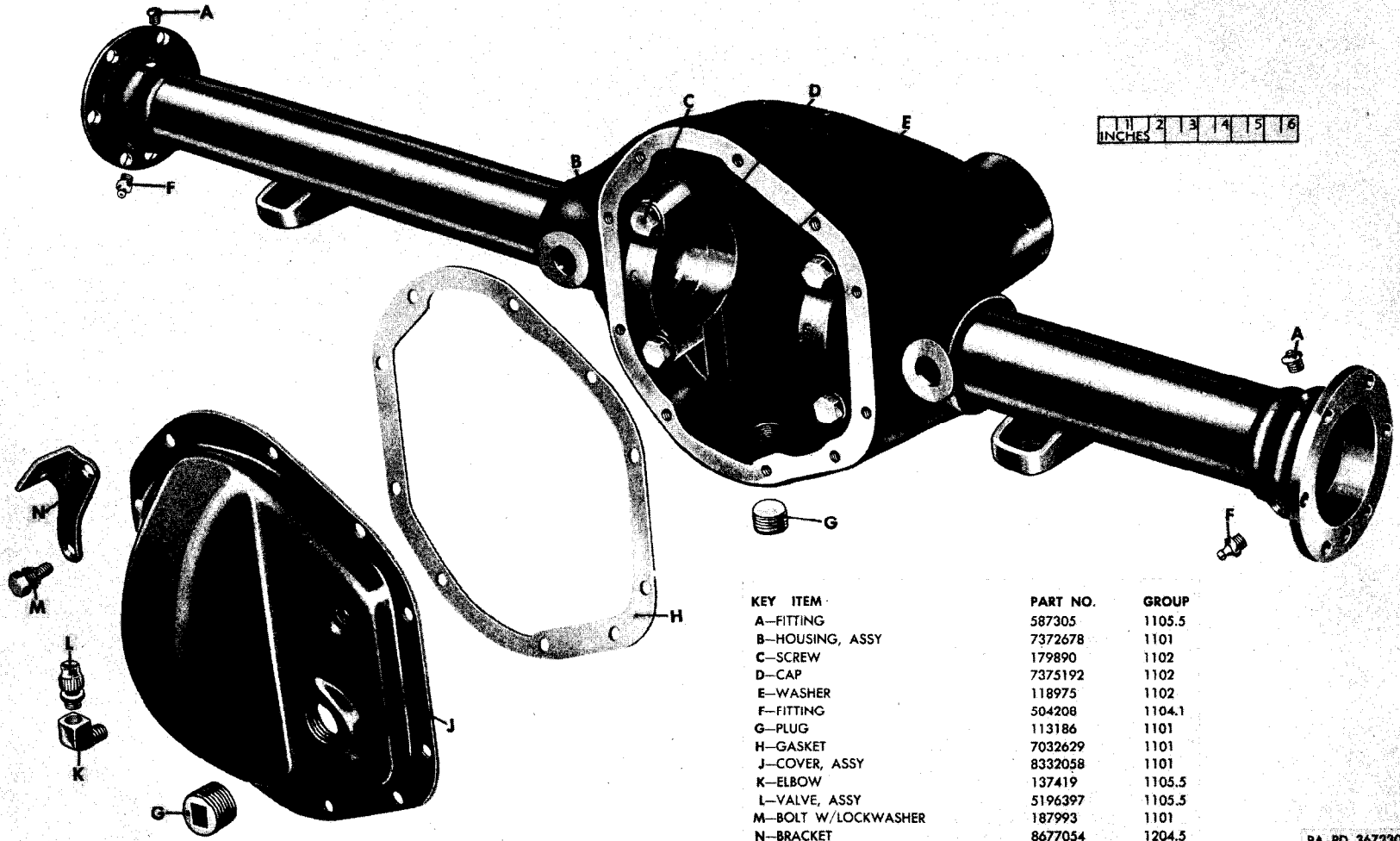
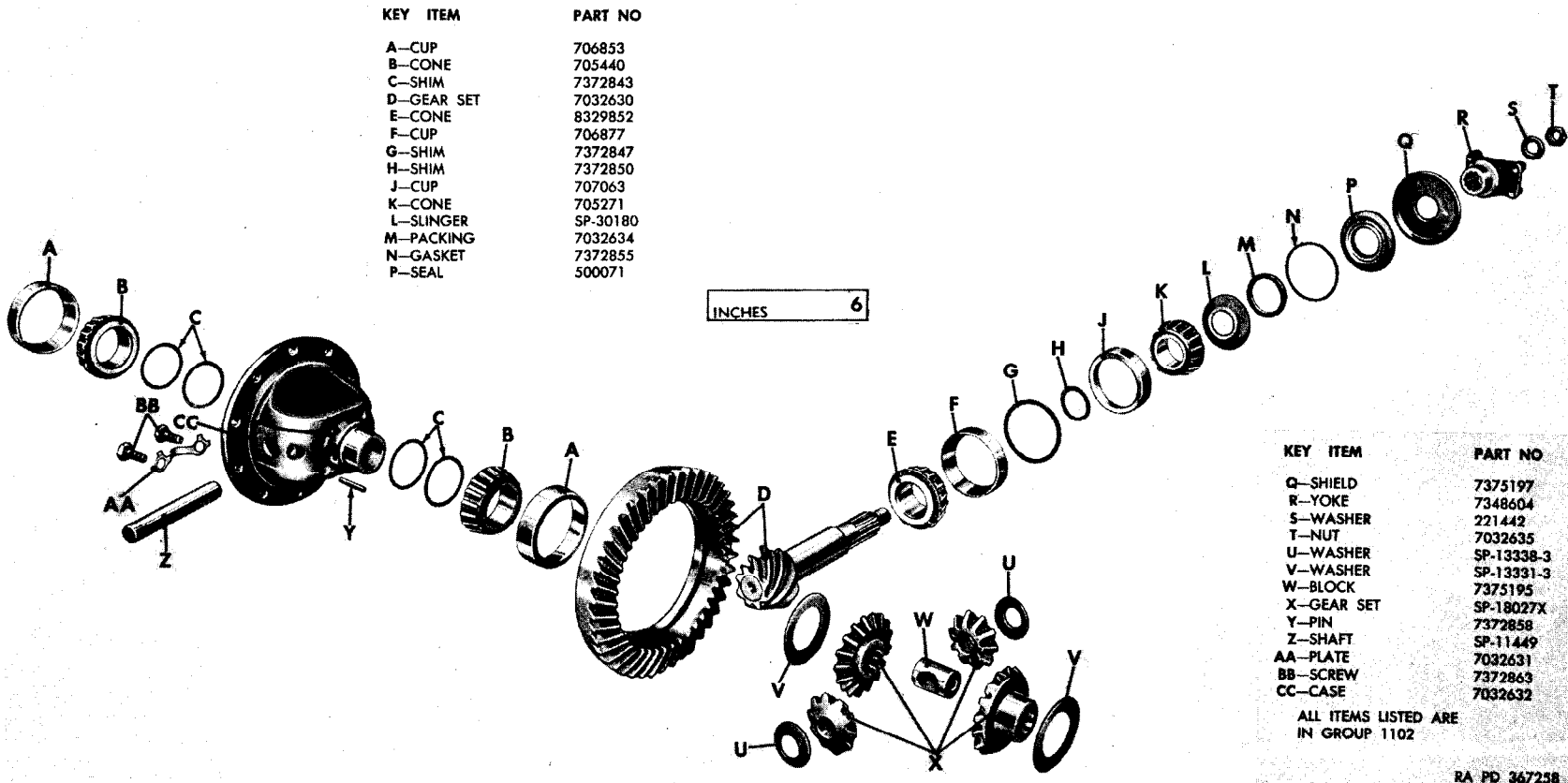

Figure 11-2. Rear axle housing—exploded view



| KEY ITEM | PART NO |
|------------|----------|
| A—CUP | 706853 |
| B—CONE | 705440 |
| C—SHIM | 7372843 |
| D—GEAR SET | 7032630 |
| E—CONE | 8329852 |
| F—CUP | 706877 |
| G—SHIM | 7372847 |
| H—SHIM | 7372850 |
| J—CUP | 707063 |
| K—CONE | 705271 |
| L—SLINGER | SP-30180 |
| M—PACKING | 7032634 |
| N—GASKET | 7372855 |
| P—SEAL | 500071 |

INCHES 6

| KEY ITEM | PART NO |
|------------|------------|
| Q—SHIELD | 7375197 |
| R—YOKE | 7348604 |
| S—WASHER | 221442 |
| T—NUT | 7032635 |
| U—WASHER | SP-13338-3 |
| V—WASHER | SP-13331-3 |
| W—BLOCK | 7375195 |
| X—GEAR SET | SP-18027X |
| Y—PIN | 7372858 |
| Z—SHAFT | SP-11449 |
| AA—PLATE | 7032631 |
| BB—SCREW | 7372863 |
| CC—CASE | 7032632 |

ALL ITEMS LISTED ARE IN GROUP 1102

RA PD 367258

Figure 11-3. Rear axle differential case and gears—exploded view

| KEY ITEM | PART NO | GROUP | KEY ITEM | PART NO | GROUP | KEY ITEM | PART NO | GROUP |
|-----------------|---------|--------|---------------|-----------|--------|----------|-----------|--------|
| A—HOUSING, ASSY | 7372678 | 1101 | F—RETAINER | 7351313 | 1104.1 | N—KEY | 7375136 | 1104.1 |
| B—SEAL | 7374988 | 1104.1 | G—BRAKE, ASSY | 8X-303136 | 1202 | P—WASHER | 7375138 | 1104.1 |
| C—CONE | 705447 | 1311 | H—GASKET | 7697463 | 1202 | Q—NUT | 7032606 | 1104.1 |
| D—CUP | 706857 | 1311 | J—SEAL | 8332519 | 1311 | R—PIN | 137204 | 1104.1 |
| E—SHIM | 7374983 | 1104.1 | K—SLINGER | 7697464 | 1202 | S—CAP | 7375143 | 1311 |
| | | | L—HUB | 8333106 | 1311 | T—BOLT | 137991 | 1311 |
| | | | M—DRUM | 7328371 | 1311 | U—STUD | 7328293 | 1311 |
| | | | | | | V—NUT | WO-909393 | 1202 |
| | | | | | | W—WASHER | 120382 | 1202 |
| | | | | | | X—SHAFT | 7374986 | 1104.1 |
| | | | | | | Y—BOLT | 181370 | 1202 |

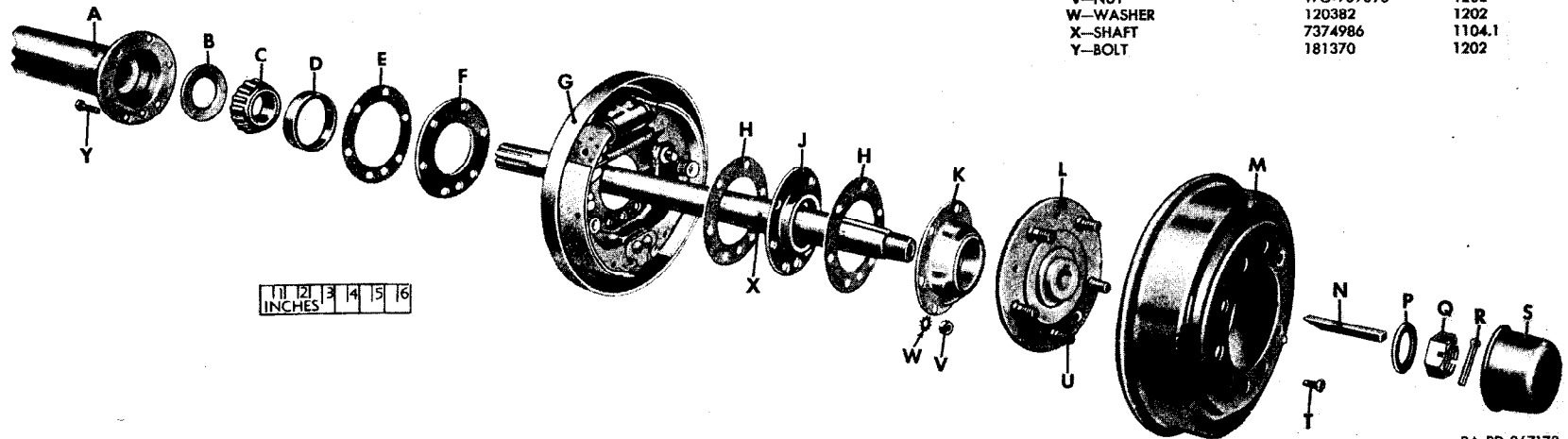

RA PD 367173

Figure 11-4. Rear wheel connecting parts—exploded view

| (1) ILLUSTRATION NO. | (2) REFERENCE SYMBOLS | (3) FEDERAL STOCK NO. | (4) ORDNANCE STOCK NO. | (5) MFR'S PART NO. | (6) ORDNANCE PART NO. | (7) DESCRIPTION | (8) QUANTITY INCORPORATED IN UNIT | (9) UNIT OF ISSUE |
|---------------------------------------|--------------------------|--------------------------|---------------------------|--|-------------------------------|--|--------------------------------------|----------------------|
| GROUP 11—REAR AXLE | | | | | | | | |
| 1100—REAR AXLE ASSEMBLY | | | | | | | | |
| 11-1 | | | G758-8329854 | SP-2167-1 WO-805791 WO-807874 WO-807875 | 8677577 8329854 8673521 | AXLE, rear, assy..... AXLE, rear, w/BRAKES, HUB, and brake DRUM, assy.. AXLE, rear, w/o BRAKES, HUB, and brake DRUM, assy | 1 1 1 | ea ea ea |
| 1101—HOUSING, COVER, AND PLUGS | | | | | | | | |
| 11-2 | | | G758-8329850 | SP-20075X WO-807267 | 8329850 | COVER, w/BAFFLE (superseded by COVER 8332058)..... | 1 | ea |
| 11-2 | | | G758-8332058 | SP-20124X WO-809548 | 8332058 | COVER, w/BAFFLE (supersedes COVER 8329850)..... | 1 | ea |
| 11-2 | H1 | 018-7993 | H101-0187993 | | 187993 | BOLT, ext-teeth-lock washer, hex-hd, S, cd- or zn-pltd, $\frac{5}{16}$ -18NC-2 x $\frac{3}{4}$ | 10 | ea |
| 11-2 | | 2520-703-2629 | G740-7032629 | SP-18434 WO-802556 | 7032629 | GASKET, axle housing cover..... | 1 | ea |
| 11-2, 4 | | | G740-7372678 | SP-18634X WO-802552 | 7372678 | HOUSING, gear carrier, w/TUBE, assy..... | 1 | ea |
| 11-2 | H6 | | H006-0283765 | | 113186 | PLUG, pipe, sq-socket, hdls, MI, $\frac{3}{4}$ in. (filler and drain)... | 2 | ea |
| 1102—DIFFERENTIAL | | | | | | | | |
| 11-3 | | 2530-737-5195 | G740-7375195 | SP-13810 WO-640965 | 7375195 | BLOCK, drive shaft..... | 1 | ea |
| 11-2 | | | G740-7375192 | SP-15365 WO-639818 | 7375192 | CAP, bearing..... | 2 | ea |
| 11-2 | H1 | 017-9890 | H101-0179890 | | 179890 | SCREW, cap, hex-hd, S, 85,000 psi yield strength, $\frac{1}{2}$ -13NC-3 x $2\frac{1}{4}$ | 4 | ea |
| 11-2 | H1 | | H001-1520005 | | 118975 | WASHER, LOCK, int-teeth, hv, S, $\frac{1}{2}$ in. (flat type).... | 4 | ea |
| 11-3 | | 2520-703-2632 | G740-7032632 | SP-18458 WO-802562 | 7032632 | CASE..... | 1 | ea |
| 11-3 | H12 | | H012-6147940 | | 705440 | CONE, tapered, roller bearing, MIL-STD-CODE 711- 25577-3000 (includes rollers and cage, SR, 1.6880 bore, 1.0000 width) (case bearing) | 2 | ea |
| 11-3 | H12 | | H012-8329852 | | 8329852 | CONE, tapered, roller bearing, MIL-STD-CODE 711- 31593-3000 (includes rollers and cage, SR, 1.3750, 1.1250 width) (drive pinion inner bearing) | 1 | ea |

1102

228

| (1) ILLUSTRATION NO. | (2) REFERENCE SYMBOLS | (3) FEDERAL STOCK NO. | (4) ORDNANCE STOCK NO. | (5) MFR'S PART NO. | (6) ORDNANCE PART NO. | (7) DESCRIPTION | (8) QUANTITY INCORPORATED IN UNIT | (9) UNIT OF ISSUE |
|-------------------------------------|--------------------------|--------------------------|---------------------------|--|--------------------------|--|--------------------------------------|----------------------|
| GROUP 11—REAR AXLE—Continued | | | | | | | | |
| 1102—DIFFERENTIAL—Continued | | | | | | | | |
| 11-3 | H12 | | H012-6122200 | | 705271 | CONE, tapered, roller bearing, MIL-STD-CODE 719-02872-3000 (includes rollers and cage, SR, 0.1250 bore, 0.8750 width) (drive pinion outer bearing) | 1 | ea |
| 11-3 | H12 | | H012-6221280 | | 706853 | CUP, tapered, roller bearing, MIL-STD-CODE 711-25523-1000 (SR, 3.2650 OD, 0.8750 width) (case bearing) | 2 | ea |
| 11-3 | H12 | | H012-6224700 | | 706877 | CUP, tapered roller bearing, MIL-STD-CODE 711-31520-1000 (SR, 3.0000 OD, 0.9375 width) (drive pinion inner bearing) | 1 | ea |
| 11-3 | H12 | | H012-6209700 | | 707063 | CUP, tapered roller bearing, MIL-STD-CODE 719-02820-1000 (SR, 2.8750 OD, 0.6875 width) (drive pinion outer bearing) | 1 | ea |
| | | 2520-737-2679 | G740-7372679 | SP-18599-7X WO-802557 | 7372679 | DIFFERENTIAL, assy (43-8T, 5.38 ratio) | 1 | ea |
| 11-3 | | 2530-737-2855 | G740-7372855 | SP-S171 WO-636565 SP-17716 WO-647061 | 7372855 8677294 | GASKET, bevel pinion oil seal | 1 | ea |
| | | | | SP-18530 WO-802559 | 7994912 | GEAR, hypoid, bevel drive, 43T | 2 | ea |
| 11-3 | | | G740-7032631 | SP-18429 WO-802561 | 7032631 | PLATE, lock, drive gear | 1 | ea |
| 11-3 | | 5305-737-2863 | G740-7372863 | SP-30187 WO-649454 | 7372863 | SCREW, hex-hd, 3/8-24NF-3 x 1 1/16 | 5 | ea |
| 11-3 | | | | SP-18027X WO-647063 | | GEAR SET, differential, bevel, matched | 10 | ea |
| | | | | | 8677294 8677295 | Composed of: 2 GEAR 2 PINION | 1 | ea |
| 11-3 | | 2520-703-2630 | G740-7032630 | SP-18528X WO-802558 | 7032630 | GEAR SET, drive, hypoid, matched, w/NUT and PINION | 1 | ea |
| 11-3 | | 5330-703-2634 | G740-7032634 | SP-17858 WO-802563 | 7032634 | PACKING, PREFORMED, felt, 1.562 ID, 2.016 OD, 0.250 thk (drive pinion oil seal) | 1 | ea |
| 11-3 | | 5315-737-2858 | G740-7372858 | SP-13449 WO-636360 SP-17717 WO-647062 | 7372858 8677295 | PIN, locking, pinion shaft | 1 | ea |
| | | | | | | PINION, bevel | 2 | ea |

| | | | | | | | | |
|------|-----|---------------|--------------|-------------------------|---------|--|---|----|
| | | | | SP-18529 WO-802560 | 7994913 | PINION, drive, hypoid, 8T..... | 1 | ea |
| 11-3 | H13 | | H013-0500071 | | 500071 | SEAL, OIL, type MLS, 1 $\frac{1}{16}$ x 3.165 x 1 $\frac{1}{32}$ (drive pinion)... | 1 | ea |
| 11-3 | | | | SP-11449 WO-636553 | | SHAFT, differential pinion..... | 1 | ea |
| 11-3 | | 2530-737-5197 | G740-7375197 | SP-17562 WO-642121 | 7375197 | SHIELD, dust (universal joint end yoke)..... | 1 | ea |
| 11-3 | | | | | | SHIM, case bearing..... | † | ea |
| | | | G740-7372843 | SP-S58 WO-639959 | 7372843 | 0.003 thk | | |
| | | | G740-7372844 | SP-S59 WO-639960 | 7372844 | 0.005 thk | | |
| | | | G740-7372845 | SP-S74 WO-639961 | 7372845 | 0.010 thk | | |
| | | | G740-7372846 | SP-S75 WO-639962 | 7372846 | 0.030 thk | | |
| 11-3 | | | | | | SHIM, drive pinion inner bearing..... | † | ea |
| | | | G740-7372847 | SP-S112 WO-639969 | 7372847 | 0.003 thk | | |
| | | | G740-7372848 | SP-S113 WO-639970 | 7372848 | 0.005 thk | | |
| | | | G740-7372849 | SP-S114 WO-639971 | 7372849 | 0.010 thk | | |
| 11-3 | | | | | | SHIM, drive pinion outer bearing..... | † | ea |
| | | | G740-7372850 | SP-S638 WO-639972 | 7372850 | 0.003 thk | | |
| | | | G740-7372851 | SP-S638-1 WO-639973 | 7372851 | 0.005 thk | | |
| | | | G740-7372852 | SP-S638-2 WO-639974 | 7372852 | 0.010 thk | | |
| | | | G740-7372853 | SP-S638-3 WO-639975 | 7372853 | 0.030 thk | | |
| | | 2520-703-2633 | G740-7032633 | SP-17857 WO-802564 | 7032633 | SLINGER, oil, drive pinion bearing (superseded by SLINGER SP-30180) | 1 | ea |
| 11-3 | | | | SP-30180 WO-908301 | | SLINGER, oil, drive pinion bearing (supersedes SLINGER 7032633) | 1 | ea |
| 11-3 | | | | SP-13338-3 WO-645790 | | WASHER, FLAT, countersunk, S, $\frac{9}{64}$ ID, $1\frac{21}{32}$ OD, 0.032 thk (thrust, differential pinion) | 2 | ea |
| 11-3 | | | | SP-13331-3 WO-645789 | | WASHER, FLAT, S, $1\frac{1}{64}$ ID, $2\frac{13}{16}$ OD, 0.032 thk (thrust, differential side gear) | 2 | ea |
| 11-3 | | 2520-734-8604 | G740-7348604 | SP-2-4-581 WO-A1446 | 7348604 | YOKE, propeller shaft, universal joint..... | 1 | ea |

| (1) ILLUSTRATION NO. | (2) REFERENCE SYMBOLS | (3) FEDERAL STOCK NO. | (4) ORDNANCE STOCK NO. | (5) MFR'S PART NO. | (6) ORDNANCE PART NO. | (7) DESCRIPTION | (8) QUANTITY INCORPORATED IN UNIT | (9) UNIT OF ISSUE |
|--|--------------------------|--------------------------|---------------------------|-------------------------------------|--------------------------|--|--------------------------------------|----------------------|
| GROUP 11—REAR AXLE—Continued | | | | | | | | |
| 1102—REAR AXLE DIFFERENTIAL—Continued | | | | | | | | |
| 11-3 | H1 | | G758-8328005 | SP-2-4-1451X WO-807693 | 8328005 | YOKE, propeller shaft, universal joint, assy..... | 1 | ea |
| | | | H101-7032635 | | 7032635 | NUT, hex, "Huglock" type, 3/4-16NF-2..... | 1 | ea |
| | | | G740-7372868 | SP-S1056 WO-636570 | 7372868 | WASHER, FLAT, S, 49/64 ID, 1 1/2 OD, 0.1196 thk (superseded by WASHER 221442) | 1 | ea |
| 11-3 | H1 | | H001-7036380 | | 221442 | WASHER, FLAT, S, 49/64 ID, 1 1/2 OD, 0.1196 thk (supersedes WASHER 7372868) | 1 | ea |
| 1104.1—SHAFT | | | | | | | | |
| 11-2 | H16 | 050-4208 | H016-0504208 | | 504208 | FITTING, lubr, hyd, surface check, stght, 1/8NPT, male (rear wheel brg) | 2 | ea |
| 11-4 | | | G740-7375136 | WO-636374 | 7375136 | KEY, tall, rectangle, one taper, champer end, S, 0.3175 in. x 0.250 x 2 7/8 lg (axle shaft, rear) | 2 | ea |
| 11-4 | | 5310-703-2606 | G740-7032606 | SP-S161 WO-636344 | 7032606 | NUT, hex, slotted, 1-14NF-3 (axle shaft)..... | 2 | ea |
| 11-4 | H1 | 013-7204 | H101-0137204 | | 137204 | PIN, cotter, split, S, cd- or zn-pltd, 1/8 x 1 1/2 (rear axle shaft nut) | 2 | ea |
| 11-4 | | 2520-735-1313 | G740-7351313 | SP-18653 WO-802887 | 7351313 | RETAINER, bearing..... | 2 | ea |
| 11-4 | H13 | | H013-7374988 | | 7374988 | SEAL, oil, type MW, 1 3/8 x 2.286 x 1/4 (axle shaft)..... | 2 | ea |
| | | 2530-737-4987 | G740-7374987 | SP-18024 WO-640968 | 7374987 | SHAFT, axle, left..... | 1 | ea |
| | | | | SP-18022X SP-17509X WO-640966 | 8677281 | SHAFT, axle, left, assy..... | 1 | ea |
| 11-4 | | 2530-737-4986 | G740-7374986 | SP-18023 WO-640969 | 7374986 | SHAFT, axle, right..... | 1 | ea |
| | | | | SP-18021X WO-640967 | | SHAFT, axle, right, assy..... | 1 | ea |
| 11-4 | | | G740-7374983 | SP-17521-2 WO-640972 | 7374983 | SHIM, rear axle shaft bearing..... | † | ea |
| | | | G740-7374984 | SP-17521-3 WO-640973 | 7374984 | 0.005 thk | | |
| | | | G740-7374985 | SP-17521-4 WO-640974 | 7374985 | 0.010 thk | | |
| | | | | | | 0.030 thk | | |

| | | | | | | | | |
|---------------------------|-----|---------------|--------------|-----------|---------|--|---|----|
| 11-4 | | 5310-270-8837 | G740-7375138 | WO-640945 | 7375138 | WASHER, FLAT, S, 1 $\frac{1}{32}$ ID, 1 $\frac{13}{16}$ OD, $\frac{1}{8}$ thk (rear axle shaft) | 2 | ea |
| 1105.5-VENTILATION | | | | | | | | |
| 11-2 | H6 | | H006-0326500 | | 137419 | ELBOW, flared tube, inverted, 90 deg, br, $\frac{1}{8}$ tube, $\frac{1}{8}$ male pipe end (axle vent plug) | 1 | ea |
| 11-2 | H16 | | H016-0587305 | | 587305 | FITTING, lubr, pressure release vent, 4 lb relief pressure, $\frac{1}{8}$ NPT, male (housing) | 2 | ea |
| 11-2 | H16 | | H016-5196397 | | 5196397 | VALVE, air, assy | 1 | ea |

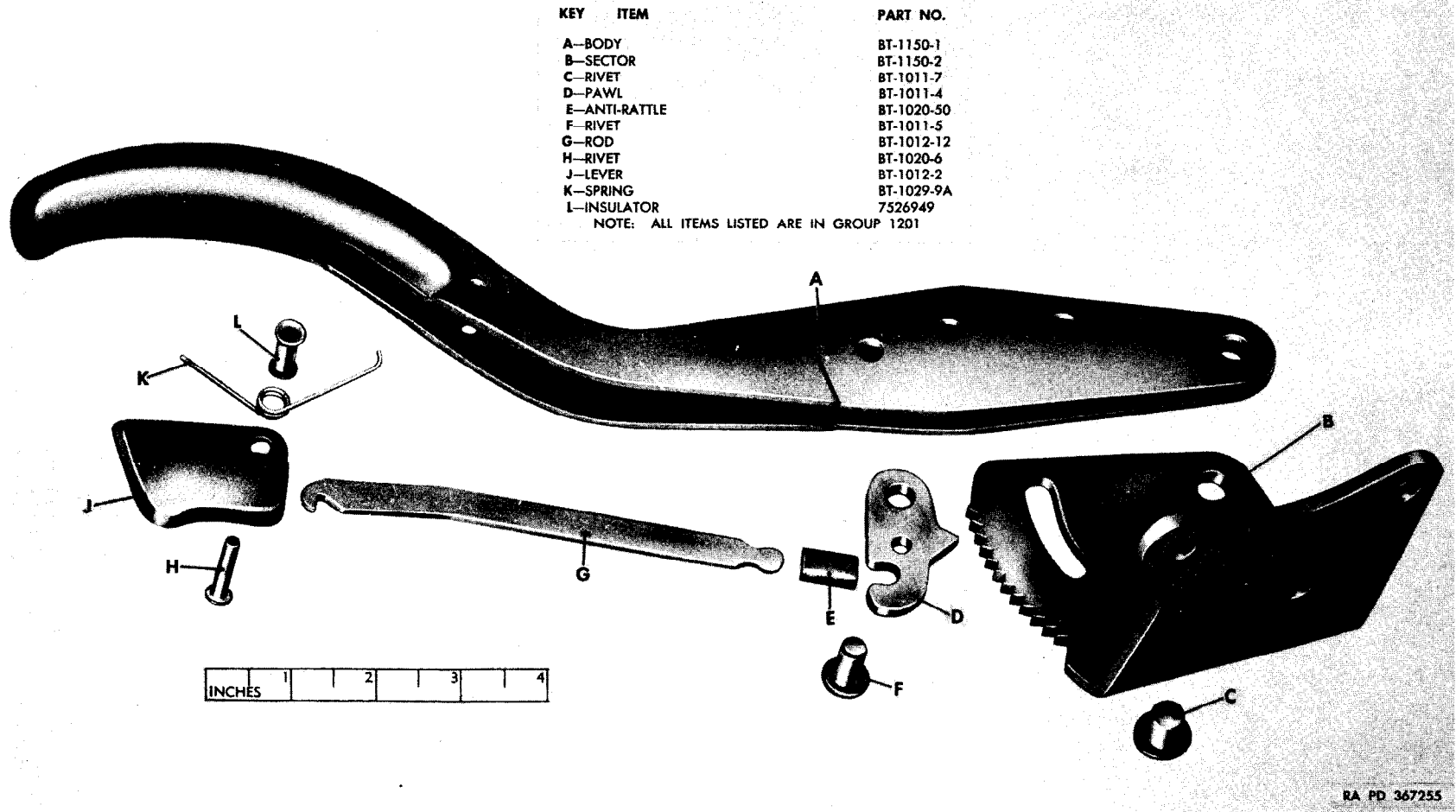
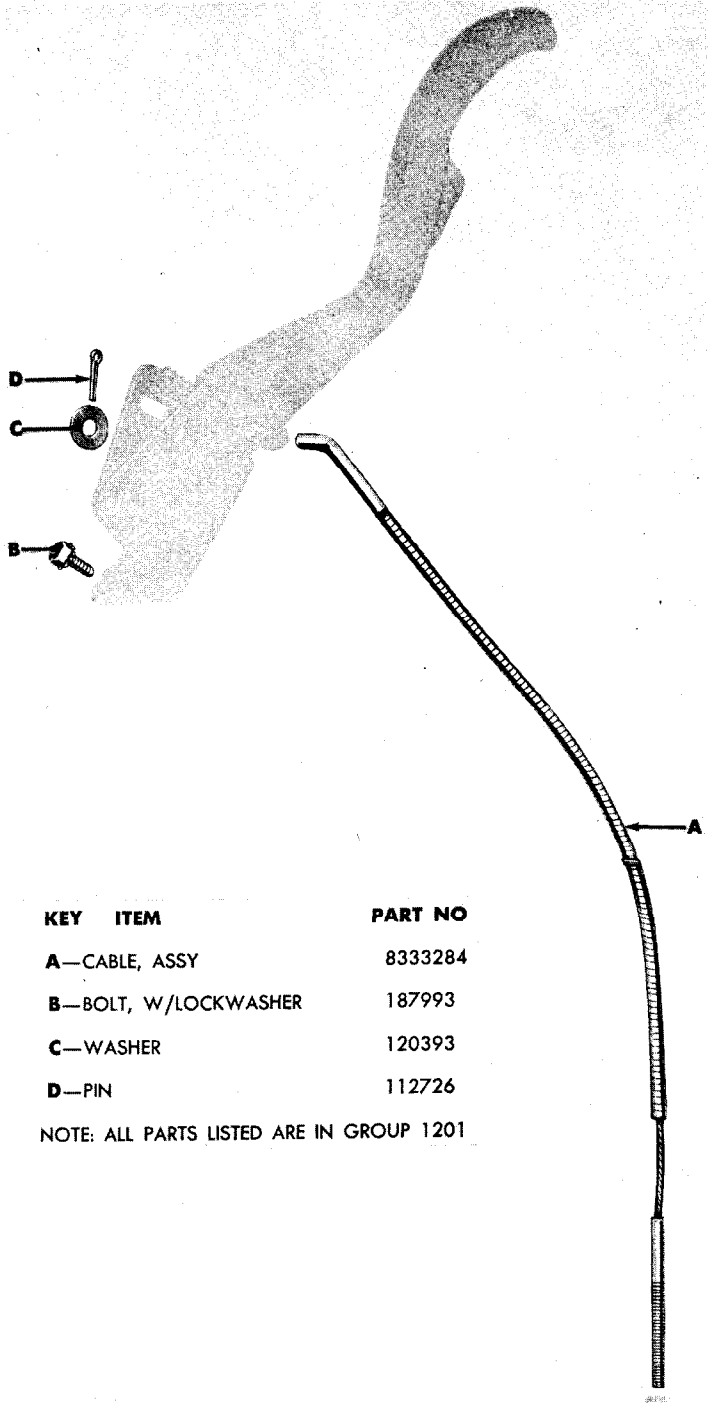
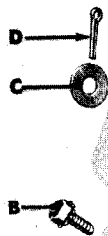
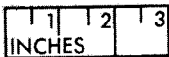

Figure 12-1. Handle, hand brake, assy (8329623)—exploded view



| KEY | ITEM | PART NO |
|-----|--------------------|---------|
| A | CABLE, ASSY | 8333284 |
| B | BOLT, W/LOCKWASHER | 187993 |
| C | WASHER | 120393 |
| D | PIN | 112726 |

NOTE: ALL PARTS LISTED ARE IN GROUP 1201



RA PD 367140

Figure 12-2. Cable, assy and related parts (M170)—exploded view

| KEY ITEM | PART NO. | GROUP |
|----------------------|-------------|--------|
| A—HANDLE, ASSY | 8329623 | 1201 |
| B—WASHER | 446363 | 1201 |
| C—SCREW W/LOCKWASHER | 9409102 | 1201 |
| D—ROD | 8329626 | 1201 |
| E—SPRING | 8329625 | 1201 |
| F—NUT | 120368 | 1201 |
| G—YOKE | 144242 | 1201 |
| H—PIN | 119117 | 1201 |
| J—LEVER | 8329633 | 1201 |
| K—SEAL | 500068 | 0802.7 |
| L—SCREW | 180132 | 0802.7 |
| M—GASKET | 7373157 | 0802.7 |
| N—WASHER | 120930 | 0802.7 |
| P—CAP | SP-18-19-33 | 0802.7 |
| Q—BEARING | 5167516 | 0802.7 |
| R—GEAR | 8328480 | 2208.1 |
| S—SLEEVE | 8328481 | 2208.1 |
| T—NUT | 124944 | 1201 |
| U—WASHER | 131205 | 1201 |
| V—PIN | 8329629 | 1201 |
| W—SHOE | TD-A3722X50 | 1201 |
| X—LINING | SP-330090 | 1201 |
| Y—LINING | SP-330091 | 1201 |
| Z—PIN | 177923 | 1201 |

| KEY ITEM | PART NO. | GROUP |
|-----------|-------------|--------|
| AA—STOP | SP-330150 | 1201 |
| BB—RIVET | TD-RV344 | 1201 |
| CC—BOLT | 7324918 | 1201 |
| DD—DRUM | 8329632 | 1201 |
| EE—SHIELD | 7696479 | 0802.7 |
| FF—FLANGE | 7371099 | 0802.7 |
| GG—WASHER | 120382 | 1201 |
| HH—NUT | 120369 | 1201 |
| JJ—NUT | 7032635 | 0802.7 |
| KK—WASHER | 7036380 | 0802.7 |
| LL—SHOE | TD-A3722V48 | 1201 |
| MM—PIN | 121741 | 1201 |

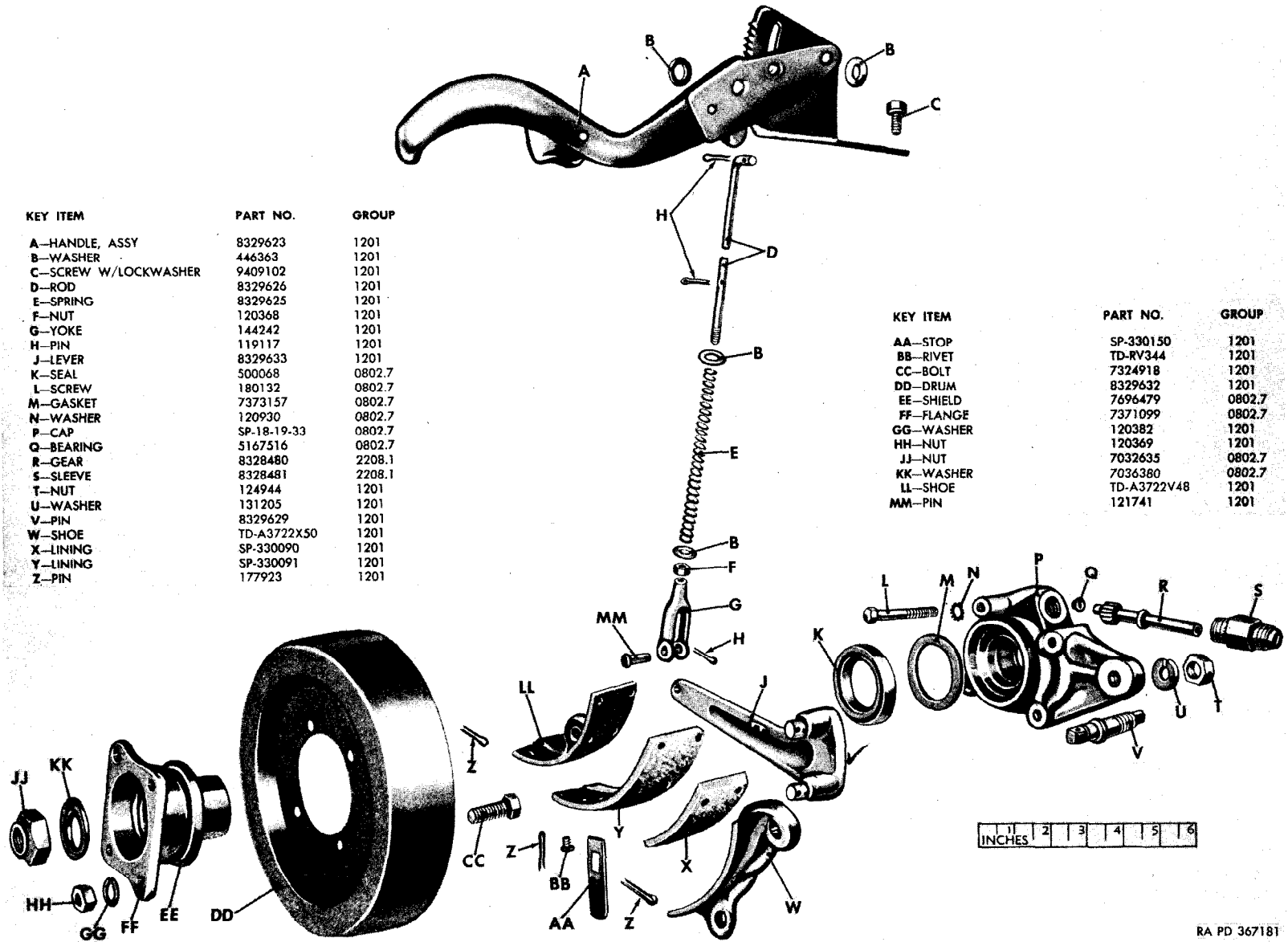

Figure 12-9. Hand brake and related parts—exploded view

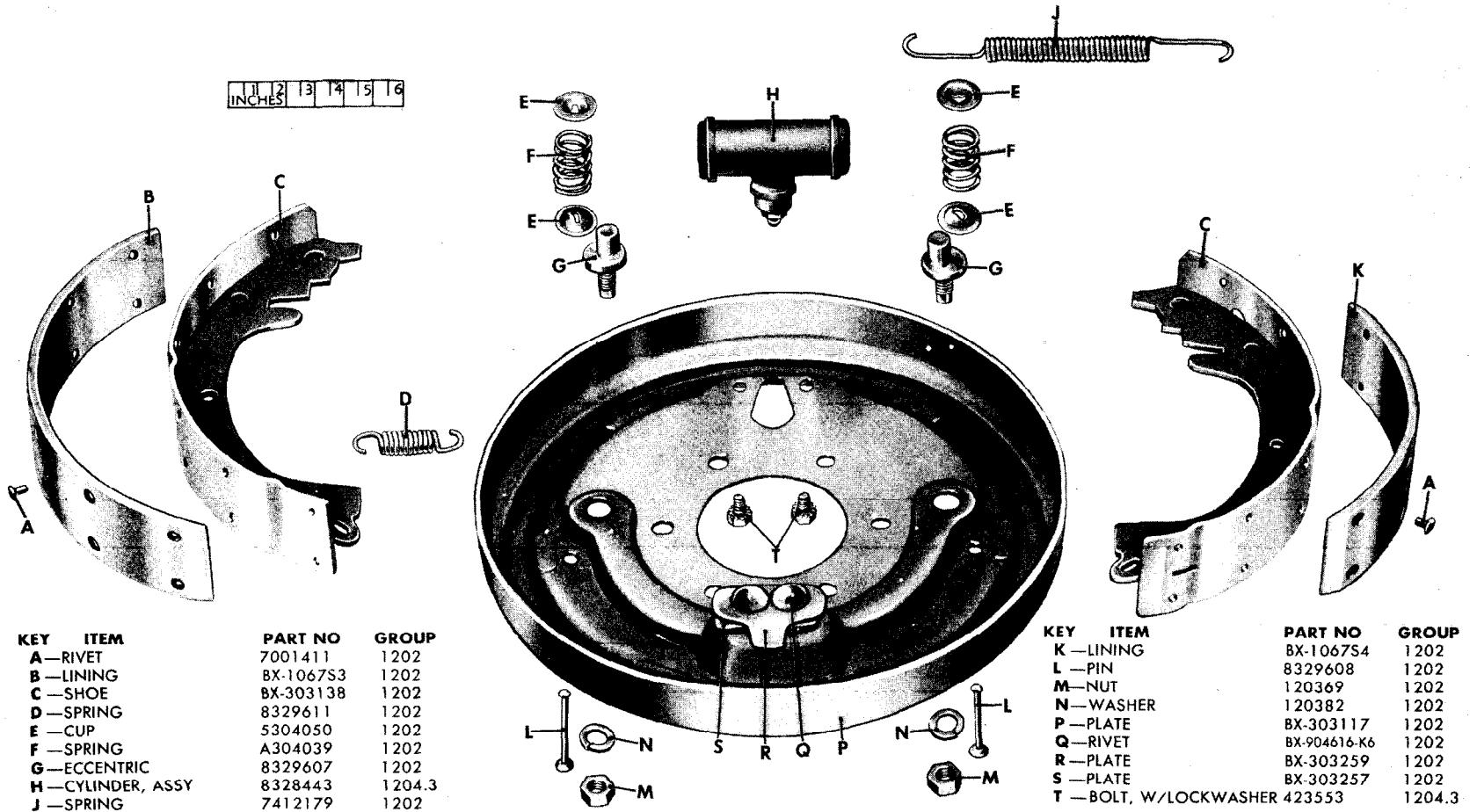

Figure 12-4. Service brake, assy—exploded view

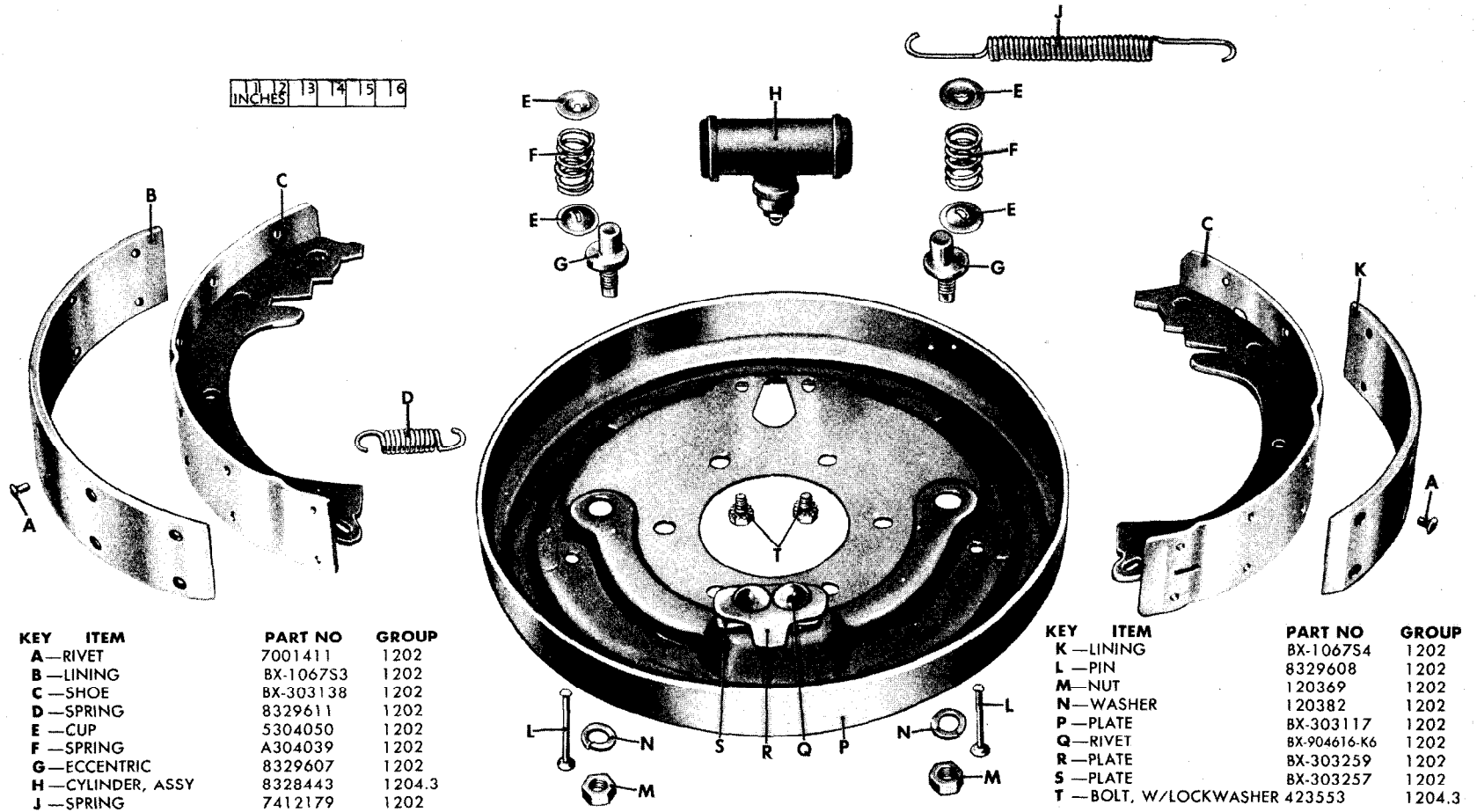

Figure 12-4. Service brake, assy—exploded view

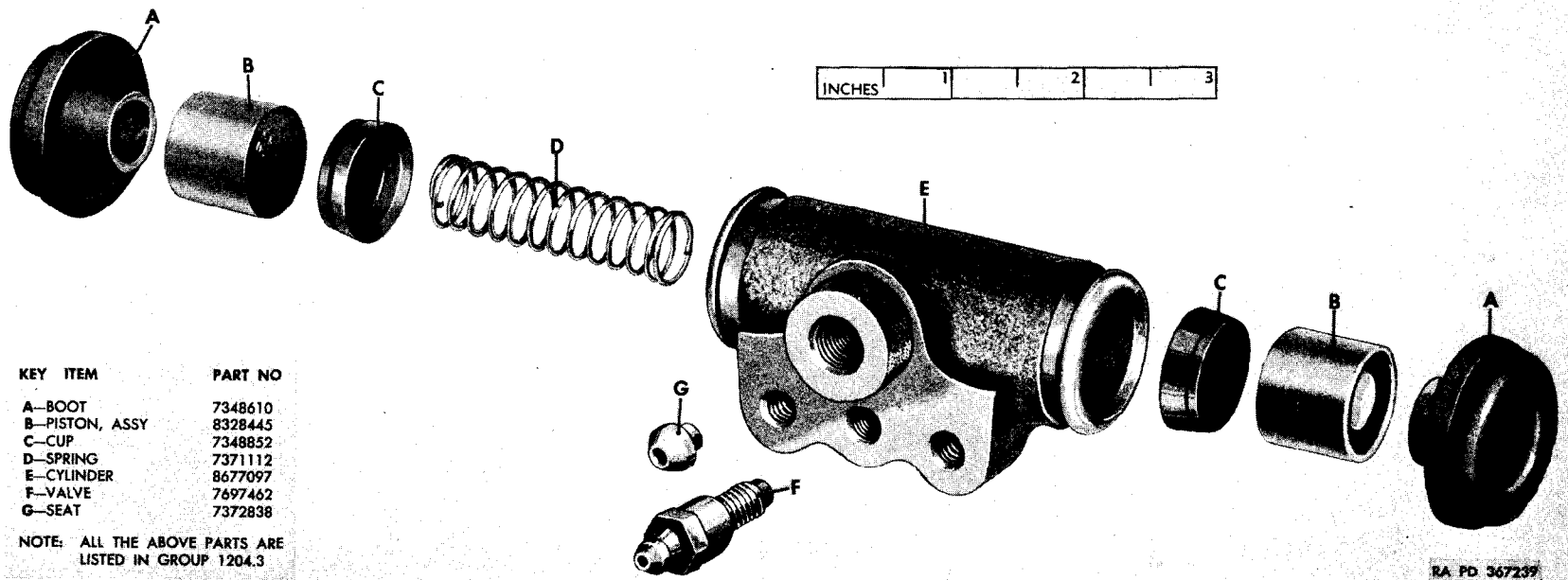

Figure 12-6. Brake wheel cylinder, assy (8328443)—exploded view

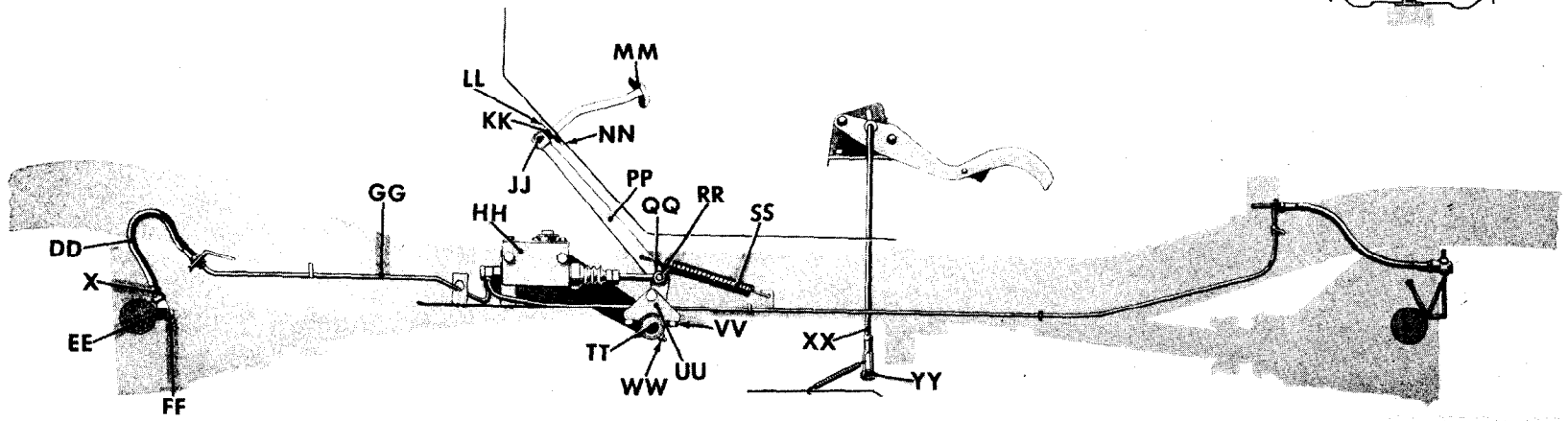
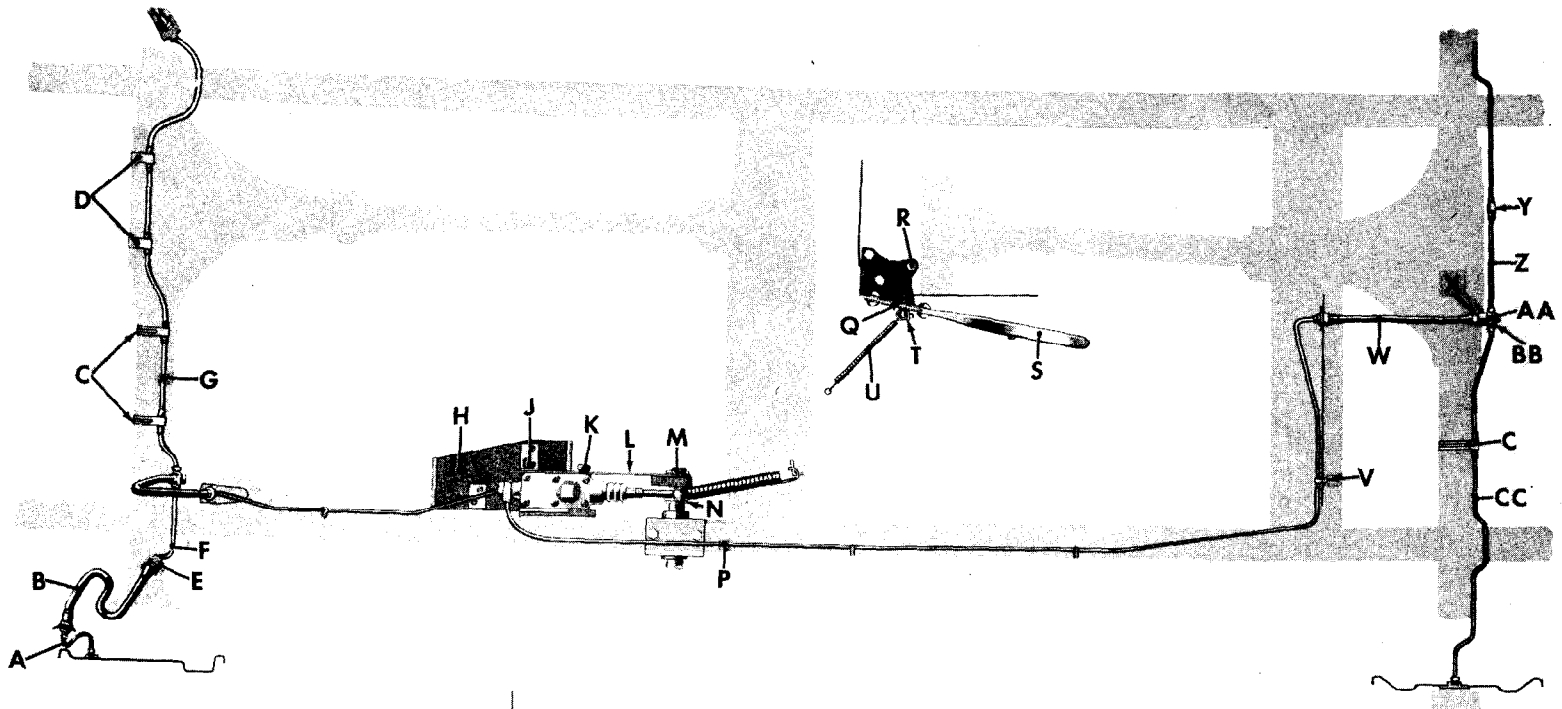
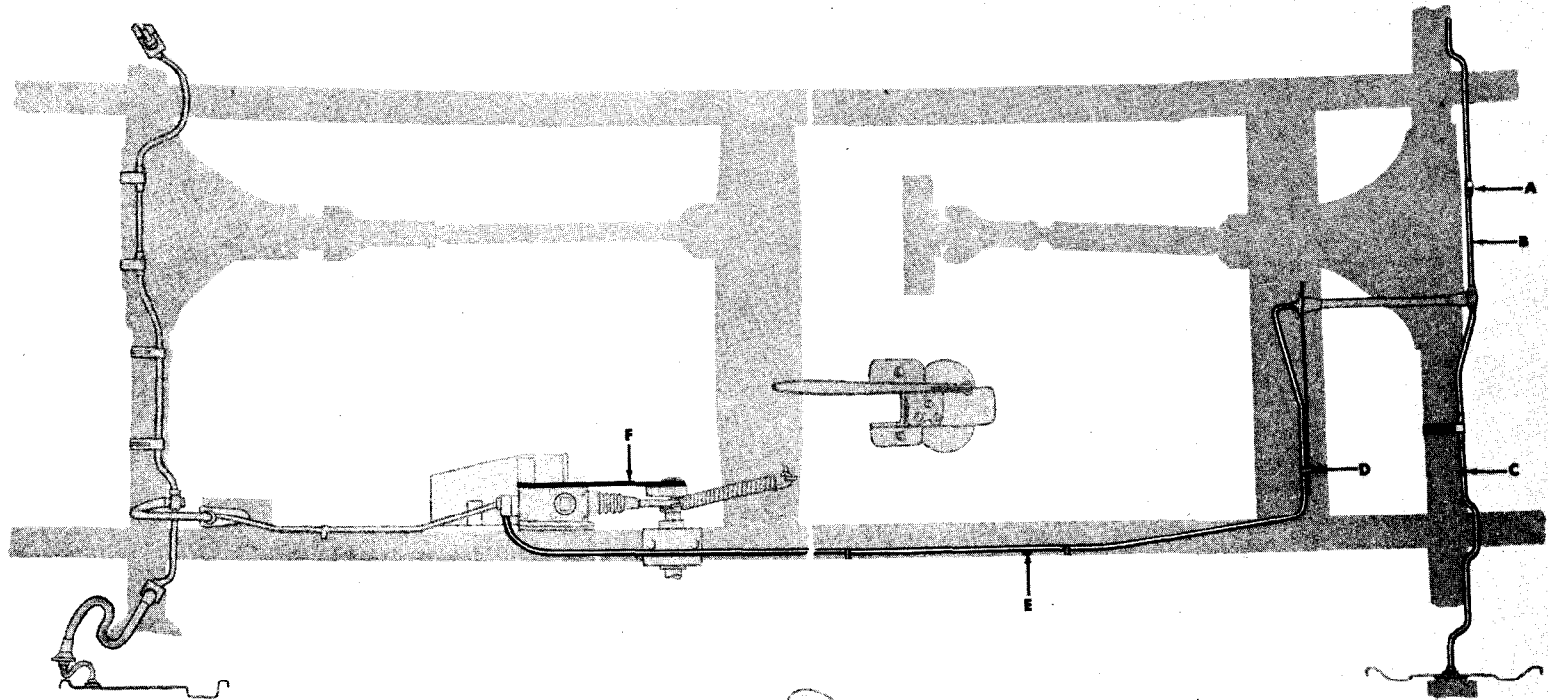

Figure 12-7. Brake system

| <i>Key</i> | <i>Item</i> | <i>Part No.</i> | <i>Group</i> | <i>Key</i> | <i>Item</i> | <i>Part No.</i> | <i>Group</i> |
|------------|-----------------------|-----------------|--------------|------------|-----------------------|-----------------|--------------|
| A | -LINE, ASSY..... | 7371009 | 1204.5 | AA | -TEE..... | 7372343 | 1204.5 |
| B | -LINE, ASSY..... | 7372836 | 1204.5 | BB | -BOLT w/LOCK WASHER.. | 187263 | 1204.5 |
| C | -RING..... | 7418146 | 1204.5 | CC | -LINE, ASSY..... | WO-905857 | 1204.5 |
| D | -CLAMP..... | 7372833 | 1204.5 | DD | -LINE, ASSY..... | 7372835 | 1204.5 |
| E | -CLIP..... | 7735289 | 1204.5 | EE | -TEE..... | 7372839 | 1204.5 |
| F | -LINE, ASSY..... | 8677344 | 1204.5 | FF | -BOLT w/LOCK WASHER.. | 423555 | 1204.5 |
| G | -LINE, ASSY..... | 8677345 | 1204.5 | GG | -LINE, ASSY..... | 8677426 | 1204.5 |
| H | -SHIELD, ASSY..... | 8329668 | 1204.1 | HH | -CYLINDER, ASSY..... | 7416524 | 1204.1 |
| J | -BOLT w/LOCK WASHER.. | 9409117 | 1204.1 | JJ | -BOLT w/LOCK WASHER.. | 9409103 | 1206 |
| K | -BOLT w/LOCK WASHER.. | 9409116 | 1204.1 | KK | -SPRING..... | 7697454 | 1206 |
| L | -BAR..... | 8677304 | 1204.1 | LL | -WASHER..... | 7954265 | 1206 |
| M | -PIN..... | 137228 | 1206 | MM | -PAD, ASSY..... | 7697466 | 1206 |
| N | -WASHER..... | 7372827 | 1206 | NN | -PAD..... | WO-906638 | 1206 |
| P | -LINE, ASSY..... | 8677618 | 1204.5 | PP | -PEDAL, ASSY..... | 7697453 | 1206 |
| Q | -PIN..... | 119117 | 1201 | QQ | -WASHER..... | 120395 | 1204.1 |
| R | -SCREW w/LOCK WASHER | 9409102 | 1201 | RR | -PIN..... | 121222 | 1204.1 |
| S | -HANDLE, ASSY..... | 8329623 | 1201 | SS | -SPRING..... | 8387940 | 1206 |
| T | -WASHER..... | 446363 | 1201 | TT | -SHAFT..... | 7340237 | 1206 |
| U | -SPRING..... | 8330948 | 1201 | UU | -BRACKET, ASSY..... | 7697452 | 1206 |
| V | -CLIP..... | 145409 | 1204.5 | VV | -BOLT..... | 123534 | 1206 |
| W | -LINE, ASSY..... | 7372837 | 1204.5 | WW | -NUT..... | 503351 | 1206 |
| X | -GASKET..... | 7372834 | 1204.5 | XX | -ROD, ASSY..... | 8329627 | 1201 |
| Y | -CLIP..... | 125912 | 1204.5 | YY | -PIN..... | 121741 | 1201 |
| Z | -LINE, ASSY..... | WO-905858 | 1204.5 | | | | |

Figure 12-7. Brake system—legend

240



| KEY ITEM | PART NO | GROUP |
|--------------|-----------|--------|
| A-CLIP | 140776 | 1204.5 |
| B-LINE, ASSY | WO-905858 | 1204.5 |
| C-LINE, ASSY | WO-905857 | 1204.5 |

| KEY ITEM | PART NO | GROUP |
|--------------|-----------|--------|
| D-CLIP | 145409 | 1204.5 |
| E-LINE, ASSY | WO-808905 | 1204.5 |
| F-BAR | WO-906171 | 1204.1 |

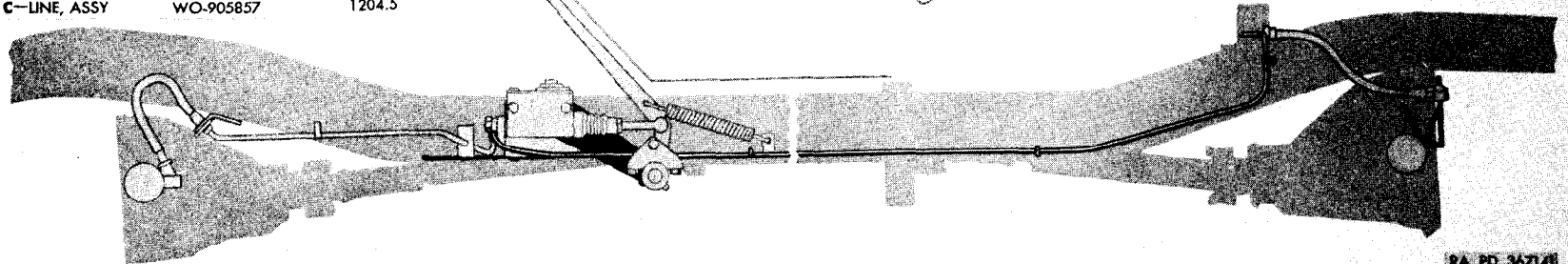

BA PD 36714

Figure 12-8. Brake system (M170)

| (1) | (2) | (3) | (4) | (5) | (6) | (7) | (8) | (9) |
|------------------------|-------------------|-------------------|--------------------|--------------------------------------|-------------------|--|-------------------------------|---------------|
| ILLUSTRATION NO. | REFERENCE SYMBOLS | FEDERAL STOCK NO. | ORDNANCE STOCK NO. | MFR'S PART NO. | ORDNANCE PART NO. | DESCRIPTION | QUANTITY INCORPORATED IN UNIT | UNIT OF ISSUE |
| GROUP 12—BRAKES | | | | | | | | |
| 1201—HAND BRAKE | | | | | | | | |
| 12-1 | | | | BT-1020-50 | | ANTI-RATTLE, pawl rod..... | 1 | ea |
| 12-1 | | | | BT-1150-1 | | BODY..... | 1 | ea |
| 12-1 | | | | BT-1011-7 | | RIVET, body to sector..... | 1 | ea |
| | | | | WO-811473 | | BRACKET, cable, w/weld NUT, assy (M170) (transfer case) | 1 | ea |
| | H1 | 018-7993 | H101-0187993 | | 187993 | BOLT, INTEGRAL LOCK WASHER, ext-teeth, hex-hd, S, cd- or zn-pltd, $\frac{5}{16}$ -18NC x $\frac{3}{4}$ | 4 | ea |
| | | | | WO-811598 | | BRACKET, w/weld NUT, assy (M170)..... | 1 | ea |
| | H1 | 018-7993 | H101-0187993 | | 187993 | BOLT, INTEGRAL LOCK WASHER, ext-teeth, hex-hd, S, cd- or zn-pltd, $\frac{5}{16}$ -18NC x $\frac{3}{4}$ | 3 | ea |
| | | | | SP-310085 WG-ASI-A34 WO-807499 | | BRAKE, transmission, int-ext pinch type, assy..... | 1 | ea |
| 12-2 | | | G758-8333284 | WO-811475 | 8333284 | CABLE, control (M170)..... | 1 | ea |
| 12-2 | H1 | | H001-4417121 | | 112726 | PIN, cotter, split, S, pltd, $\frac{1}{16}$ x $\frac{1}{2}$ | 1 | ea |
| 12-2 | H1 | 5310-012-0393 | H101-7043711 | | 120393 | WASHER, FLAT, S, cd- or zn-pltd, $\frac{11}{32}$ ID, $\frac{11}{16}$ OD, 0.094 thk (cable to hand brake) | 1 | ea |
| | | | G503-7697855 | WO-638780 | 7697855 | CLAMP, conduit (superseded by CLAMP 7348611) (M170) | 2 | ea |
| | | | G740-7348611 | | 7348611 | CLAMP, conduit (supersedes CLAMP 7697855) (M170) | 2 | ea |
| | H1 | 018-7993 | H101-0187993 | | 187993 | BOLT, INTEGRAL LOCK WASHER, ext-teeth, cross-recess, hex-hd, sltd, S, cd- or zn-pltd, $\frac{5}{16}$ -18NC x $\frac{5}{8}$ (cable clamp to hand brake bracket (1), to transfer case bracket (1)) | 2 | ea |
| 08-2; 12-3 | | | G758-8329632 | SP-330086 WG-4802 WO-806026 | 8329632 | DRUM..... | 1 | ea |
| 08-2; 12-3 | | 5305-732-4918 | G503-7324918 | SP-6-73-218 WO-A997 | 7324918 | BOLT, hex-hd, S, $\frac{3}{8}$ -24NF-3 x $1\frac{1}{2}$ | 4 | ea |
| 08-2; 12-3 | H1 | 012-0369 | H001-4167601 | | 120369 | NUT, PLAIN, HEXAGON, S, cd- or zn-pltd, $\frac{3}{8}$ -24UNF-2B | 4 | ea |
| 12-3 | H1 | 5310-012-0382 | H001-7025741 | | 120382 | WASHER, LOCK, med, S, cd- or zn-pltd, $\frac{3}{8}$ in..... | 4 | ea |
| 12-3, 7 | | | G758-8329623 | BT-1150 WO-806115 | 8329623 | HANDLE, assy..... | 1 | ea |
| 12-3, 7 | H1 | | H101-9409102 | | 9409102 | SCREW, hex-hd, w/lock WASHER, S, cd- or zn-pltd, $\frac{5}{16}$ -24NF-2 x $\frac{3}{4}$ | 3 | ea |
| 12-1 | H4 | 752-6949 | H004-7526949 | | 7526949 | INSULATOR..... | 1 | ea |
| 12-1 | | | | BT-1020-6 | | RIVET..... | 1 | ea |

1201

| (1) ILLUSTRATION NO. | (2) REFERENCE SYMBOLS | (3) FEDERAL STOCK NO. | (4) ORDNANCE STOCK NO. | (5) MFR'S PART NO. | (6) ORDNANCE PART NO. | (7) DESCRIPTION | (8) QUANTITY INCORPORATED IN UNIT | (9) UNIT OF ISSUE |
|----------------------------------|--------------------------|--------------------------|---------------------------|---------------------------------------|--------------------------|--|--------------------------------------|----------------------|
| GROUP 12—BRAKES—Continued | | | | | | | | |
| 1201—HAND BRAKE—Continued | | | | | | | | |
| 08-2 | | | G758-8329633 | SP-330087 WG-A34-15 WO-806025 | 8329633 | LEVER, operating | 1 | ea |
| 12-1 | | | | BT-1012-2 | | LEVER, release | 1 | ea |
| 08-2; 12-3 | | | | SP-330091 WO-806034 | | LINING, brake shoe, inner | 1 | ea |
| 08-2; 12-3 | | | | SP-330090 WO-806035 | | LINING, brake shoe, outer | 1 | ea |
| 12-3 | H1 | 012-0368 | H001-4167561 | | 120368 | NUT, PLAIN, HEXAGON, lt, s-fin, S, cd- or zn-pltd, $\frac{5}{16}$ -24NF-2 (hand brake rod) | 1 | ea |
| 12-1 | | | | BT-1011-4 | | PAWL, racket stop | 1 | ea |
| 12-1 | | | | BT-1011-5 | | RIVET, pawl to body | 1 | ea |
| 08-2; 12-3 | | | G758-8329629 | SP-330088 WG-A34-18 WO-805777 | 8329629 | PIN, anchor brake | 1 | ea |
| 08-2; 12-3 | H1 | 012-4944 | H001-4185761 | | 124944 | NUT, PLAIN, HEXAGON, lt, s-fin, S, cd- or zn-pltd, $\frac{5}{8}$ -18NF-2 | 1 | ea |
| 08-2; 12-3 | H1 | 013-1205 | H001-7023871 | | 131205 | WASHER, LOCK, S, cd- or zn-pltd, $\frac{5}{8}$ in. | 1 | ea |
| 12-3, 7 | H1 | 011-9117 | H101-0119117 | | 119117 | PIN, COTTER, S, cd- or zn-pltd, $\frac{3}{32}$ x $\frac{1}{2}$ (clevis pin (2), rod to hand brake (1)) | 3 | ea |
| 08-2; 12-3 | H1 | 017-7923 | H101-0177923 | | 177923 | PIN, COTTER, S, cd-pltd, $\frac{1}{8}$ x $\frac{3}{4}$ (operating lever) | 2 | ea |
| | H1 | 013-7185 | H001-4417731 | | 137185 | PIN, COTTER, split, S, pltd, $\frac{1}{8}$ x 1 (anchor pin) | 1 | ea |
| 12-3, 7 | H1 | 012-1741 | H001-4541581 | | 121741 | PIN, STRAIGHT, HEADED, hardened, S, cd- or zn-pltd, $\frac{5}{16}$ x $1\frac{13}{16}$ (rod) | 1 | ea |
| 08-2; 12-3 | | | | TD-RV344 WO-119477 | | RIVET, tubular, br, $\frac{3}{16}$ x $\frac{1}{4}$ (inner and outer brake shoe lining) | 14 | ea |
| 12-3 | | | G758-8329626 | WO-806117 | 8329626 | ROD, operating lever | 1 | ea |
| 12-7 | | | G758-8329627 | WO-806116 | 8329627 | ROD, operating lever, w/SPRING, assy | 1 | ea |
| 12-1 | | | | BT-1012-12 | | ROD, pawl | 1 | ea |
| 12-1 | | | | BT-1150-2 | | SECTOR, ratchet | 1 | ea |
| | | | | SP-310059 WG-AA34-12 WO-806028 | | SHOE, brake, inner, assy | 1 | ea |
| | | | | SP-310058 WG-AA34-12A WO-806027 | | SHOE, brake, outer, assy | 1 | ea |
| 08-2; 12-3 | | | | TD-T1-3722-V-48 | | SHOE, inner | 1 | ea |

242

| | | | | | | | | |
|------------|----|---------------|--------------|-----------------|---------|--|----|----|
| 08-2; 12-3 | | | | TD-TI-722-8-333 | | SHOE, outer..... | 1 | ea |
| 12-1 | | | | BT-1029-9A | | SPRING, release lever..... | 1 | ea |
| 12-3, 7 | | | | G758-8330948 | 8330948 | SPRING, retracting..... | 1 | ea |
| | | | | G758-8330948 | 8330948 | SPRING, tension..... | 1 | ea |
| | | | | WO-809429 | | SPRING, tension, brake cable (M170)..... | 1 | ea |
| | | | | G758-8329630 | 8329630 | STOP, transmission brake (superseded by STOP SP-330150) | 1 | ea |
| | | | | WG-A34-63 | | | | |
| | | | | SP-330089 | | | | |
| | | | | WO-805778 | | | | |
| 08-2; 12-3 | | | | SP-330150 | | STOP, transmission brake (supersedes STOP 8329630)..... | 1 | ea |
| | | | | WG-A34-63A | | | | |
| | | | | WO-810822 | | | | |
| 12-3, 7 | H1 | 044-6363 | H101-0446363 | | 446363 | WASHER, FLAT, hv, S, cd- or zn-pltd, $\frac{5}{16}$ in. (clevis pin and rod to hand brake) | 4 | ea |
| | | | | TD-1729S227 | | WASHER, spring, S, 0.516 ID, 0.812 OD, 0.094 thk (transmission brake shoe) | 2 | ea |
| | | | | SP-330151 | | | | |
| | | | | WG-4372D | | | | |
| | | | | WO-810823 | | | | |
| 12-3 | H1 | | H101-0144242 | | 144242 | YOKE, rod end, $\frac{5}{16}$ -24NF-2 x 2 $\frac{1}{4}$ (rod)..... | 1 | ea |
| | | | | | | 1202-SERVICE BRAKES | | |
| 10-6 | | | | BX-303133 | 8677617 | BRAKE, front, left, assy (self-centering)..... | 1 | ea |
| | | | | WO-807281 | | | | |
| | | | | BX-303134 | | BRAKE, front, right, assy (self-centering)..... | 1 | ea |
| | | | | WO-807282 | | | | |
| | | | | BX-303135 | 8677616 | BRAKE, rear, left, assy (self-centering)..... | 1 | ea |
| | | | | WO-807283 | | | | |
| 11-4 | | | | BX-303136 | | BRAKE, rear, right, assy (self-centering)..... | 1 | ea |
| | | | | WO-807284 | | | | |
| 12-4 | | | G518-5304050 | BX-23969 | 5304050 | CUP, retainer, shoe hold-down spring..... | 16 | ea |
| | | | | WO-391404 | | | | |
| 12-4 | | | G758-8329607 | BX-302691 | 8329607 | ECCENTRIC, adj, shoe..... | 8 | ea |
| | | | | WO-805592 | | | | |
| 12-4 | H1 | 012-0369 | H001-4167601 | | 120369 | NUT, plain, hex, reg, S, cd- or zn-pltd, $\frac{3}{8}$ -24NF-2..... | 8 | ea |
| 11-4; 12-4 | H1 | 5310-012-0382 | H001-7025741 | | 120382 | WASHER, lock, med, reg, S, cd- or zn-pltd, $\frac{3}{8}$ in..... | 8 | ea |
| 11-4 | | 2530-495-9594 | G740-7697463 | WO-640886 | 7697463 | GASKET, rear grease slinger..... | 4 | ea |
| 12-4 | | | | BX-1067S3 | | LINING, front shoe..... | 4 | ea |
| | | | | WO-116551 | | | | |
| 12-4 | | | | BX-1067S4 | | LINING, rear shoe..... | 4 | ea |
| | | | | WO-116552 | | | | |
| 12-4 | | 5320-700-1411 | G518-7001411 | BX-70S6 | 7001411 | RIVET, tubr, br, $\frac{19}{64}$ x $\frac{1}{4}$, $\frac{19}{64}$ hd dia..... | 80 | ea |
| | | | | WO-374586 | | | | |
| 12-4 | | | G758-8329608 | BX-25829 | 8329608 | PIN, shoe hold-down spring..... | 8 | ea |
| | | | | WO-807374 | | | | |

| (1) ILLUSTRATION NO. | (2) REFER- ENCE SYMBOLS | (3) FEDERAL STOCK NO. | (4) ORDNANCE STOCK NO. | (5) MFR'S PART NO. | (6) ORDNANCE PART NO. | (7) DESCRIPTION | (8) QUANTITY INCOR- PORATED IN UNIT | (9) UNIT OF ISSUE |
|--------------------------------------|----------------------------------|-----------------------------|------------------------------|-----------------------|-----------------------------|--|---|----------------------------|
| GROUP 12—BRAKES—Continued | | | | | | | | |
| 1202—SERVICE BRAKES—Continued | | | | | | | | |
| | | | G758-8329609 | BX-303128 | 8329609 | PLATE, backing, assy..... | 4 | ea |
| | H1 | 010-0025 | H001-5421220 | WO-807375 | 100025 | BOLT, hex-hd, S, $\frac{3}{8}$ -24NF-3 x $\frac{1}{8}$ (front brake) (blind hole) | 12 | ea |
| | | | | WO-807292 | | BOLT, hex-hd, S, cd- or zn-pltd, $\frac{3}{8}$ -24NF-3 x $1\frac{1}{4}$ (superseded by BOLT 181370) | 12 | ea |
| 11-4 | | | | | 181370 | BOLT, hex-hd, S, cd- or zn-pltd, $\frac{3}{8}$ -24NF x $1\frac{1}{4}$ (super- sedes BOLT WO-807292) (rear brake backing plate to axle tube flange) | 12 | ea |
| 11-4 | | | | WO-909393 | | NUT, hex, special, parkerize fin, $\frac{3}{8}$ -24NF-2 (used on vehicles after serial no. 104502) | 12 | ea |
| | H1 | 012-0369 | H001-4167601 | | 120369 | NUT, PLAIN, hexagon, reg, cd- or zn-pltd, $\frac{3}{8}$ -24NF-2 (used on vehicles up to serial no. 104502) | 12 | ea |
| 11-4 | H1 | 5310-012-0382 | H001-7025741 | | 120382 | WASHER, lock, med, S, cd- or zn-pltd, $\frac{3}{8}$ in (rear brake backing plate to axle tube flange (12) to steer knuckle (12)) | 24 | ea |
| 12-4 | | | | BX-303257 | | PLATE, brake anchor..... | 4 | ea |
| | | | | WO-808438 | | | | |
| 12-4 | | | | BX-303117 | | PLATE, brake backing..... | 4 | ea |
| | | | | WO-807367 | | | | |
| 12-4 | | | | BX-303259 | | PLATE, brake shoe retainer..... | 4 | ea |
| | | | | WO-808440 | | | | |
| 12-4 | | | | BX-904616K6 | | RIVET, rd-hd, $\frac{3}{8}$ x 1 (brake anchor plate)..... | 8 | ea |
| | | | | WO-808441 | | | | |
| 12-4 | | | | BX-303138 | | SHOE, brake, w/o LINING..... | 8 | ea |
| | | | | WO-807371 | | | | |
| | | | | BX-303173 | | SHOE, front, w/LINING, assy..... | 4 | ea |
| | | | | WO-807377 | | | | |
| | | | | BX-303174 | | SHOE, rear, w/LINING, assy..... | 4 | ea |
| | | | | WO-807378 | | | | |
| 11-4 | | 2530-495-9595 | G740-7697464 | WO-640888 | 7697464 | SLINGER, grease, rear..... | 2 | ea |
| 12-4 | | 246-7553 | G518-0389792 | BX-24784 | A304039 | SPRING, HELICAL, COMPRESSION, cylindrical, $5\frac{1}{2}$ coils, RH helix, S, $1\frac{1}{6}$ lg | 8 | ea |
| 12-4 | | 5340-741-2179 | G529-7412179 | BX-41545 | 7412179 | SPRING, helical, extn brake shoe return..... | 4 | ea |
| | | | | WO-637905 | | | | |
| 12-4 | | | G758-8329611 | BX-48772 | 8329611 | SPRING, shoe retainer (anchor end)..... | 4 | ea |
| | | | | WO-805602 | | | | |

1204.1 - MASTER CYLINDER

| | | | | | | | | |
|------------|----|---------------|--------------|-------------|---------|---|---|----|
| 12-2; 12-7 | | | | WO-647592 | 8677304 | BAR, tie (M38A1)..... | 1 | ea |
| 12-7 | H1 | | H101-9409117 | | 9409117 | BOLT, MACHINE, hex-hd, w/spring lock washer, S, cd- or zn-pltd, 3/8-24NF-2 x 3 (master cylinder clutch pedal shaft) | 1 | ea |
| 12-8 | | | | WO-906171 | | BAR, tie (master cylinder) (M170)..... | 1 | ea |
| | H1 | 5305-769-7465 | G740-7697465 | WO-647606 | 7697465 | BOLT, eye, 1/16-20NF (pedal to master cylinder)..... | 1 | ea |
| | | 012-0370 | H001-4167641 | | 120370 | NUT, plain, hex, 1/16-20NF-2..... | 1 | ea |
| 12-7 | H1 | 012-1222 | H101-0121222 | | 121222 | PIN, cotter, split, pltd, 3/32 x 3/4..... | 1 | ea |
| 12-7 | H1 | 5310-012-0395 | H001-7043771 | | 120395 | WASHER, fl, light series, S, cd- or zn-pltd, 1/16 in..... | 1 | ea |
| 12-5 | | 2530-737-5440 | G503-7375440 | LO-FC3474 | 7375440 | BOLT, sp, hex-hd, S, 1/2-20NF-2 x 1 1/2 (master cylinder outlet fitting) | 1 | ea |
| | | | | WO-637605 | | | | |
| 12-5 | | 2530-737-5176 | G740-7375176 | LO-FC12496 | 7375176 | BOOT, eye bolt to tank..... | 1 | ea |
| | | | | WO-801937 | | | | |
| 03-8; 12-5 | | 2530-741-1069 | G744-7411069 | LO-FC14577 | 7411069 | CAP, filler (used w/CYLINDER 7416524)..... | 1 | ea |
| | | | | WO-119513 | | | | |
| | | 753-9310 | G740-7539310 | LO-FC11940 | 7539310 | CAP, filler (used w/CYLINDER 7697478)..... | 1 | ea |
| | | | | WO-800713 | | | | |
| | | 2530-359-0456 | G740-7697477 | LO-FC10945 | 7697477 | COVER, supply tank (used w/CYLINDER 7697478)..... | 1 | ea |
| | | | | WO-647297 | | | | |
| | H1 | 5305-011-1655 | H101-0111655 | | 111655 | SCREW, THREADED, hex-hd, S, No. 14 (0.242) x 3/4 in. | 6 | ea |
| 12-5 | | 2530-741-7607 | G503-7417607 | LO-FD2108H | 7417607 | CUP, ru, primary, piston..... | 1 | ea |
| | | | | WO-637590 | | | | |
| | | 2530-769-7478 | G740-7697478 | LO-FE3441C | 7697478 | CYLINDER, master, assy (AL body) (optional w/CYLINDER 7416524) | 1 | ea |
| | | | | WO-648069 | | | | |
| 12-5, 7 | | 2530-741-6524 | G740-7416524 | LO-FE14054B | 7416524 | CYLINDER, master, assy (CI body) (optional w/CYLINDER 7697478) | 1 | ea |
| | | | | WO-805238 | | | | |
| | | | | WO-807203 | | CYLINDER, master, w/eye BOLT and SWITCH, assy (AL) (optional w/CYLINDER WO-807204) | 1 | ea |
| | | | | WO-807204 | | CYLINDER, master, w/eye BOLT and SWITCH, assy (CI) (optional w/CYLINDER WO-807203) | 1 | ea |
| 12-5 | | 2530-737-2342 | G503-7372342 | LO-FC5727 | 7372342 | FITTING, outlet..... | 1 | ea |
| | | | | WO-A557 | | | | |
| 12-5 | | 2530-740-9316 | G744-7409316 | LO-FC7370 | 7409316 | GASKET, filler cap (used w/CYLINDER 7416524)..... | 1 | ea |
| | | | | WO-119162 | | | | |
| | | 5330-737-3354 | G742-7373354 | LO-FC3587 | 7373354 | GASKET, filler cap (used w/CYLINDER 7697478)..... | 1 | ea |
| | | | | WO-648974 | | | | |
| 12-5 | | 5330-521-4539 | G508-5214539 | LO-FC602 | 5214539 | GASKET, outlet fitting, 0.510 ID, 1 1/16 OD, 1/32 thk..... | 1 | ea |
| | | | | WO-637604 | | | | |
| 12-5 | | 5330-516-0323 | G508-5160323 | LO-FC603 | 5160323 | GASKET, outlet fitting bolt, 0.600 ID, 1 1/16 OD, 0.032 thk.. | 1 | ea |
| | | | | WO-637606 | | | | |
| | | 2530-359-0445 | G740-7697476 | LO-FC10946 | 7697476 | GASKET, supply tank cover (used w/CYLINDER 7697478) | 1 | ea |
| | | | | WO-647289 | | | | |
| 12-5 | | | | LO-FC11140 | 8673967 | PISTON, assy..... | 1 | ea |
| | | | | WO-647286 | | | | |

| (1) ILLUSTRATION NO. | (2) REFERENCE SYMBOLS | (3) FEDERAL STOCK NO. | (4) ORDNANCE STOCK NO. | (5) MFR'S PART NO. | (6) ORDNANCE PART NO. | (7) DESCRIPTION | (8) QUANTITY INCORPORATED IN UNIT | (9) UNIT OF ISSUE |
|---|--------------------------|--------------------------|---------------------------|--------------------------|--------------------------|--|--------------------------------------|----------------------|
| GROUP 12—BRAKES—Continued | | | | | | | | |
| 1204.1—MASTER CYLINDER—Continued | | | | | | | | |
| | | | G758-8332083 | WO-809082 | 8332083 | PLUG, ventilation, filler cap, CI or S, cd- or zn-pltd, 1/8-27NPTF (used on vehicles after serial No. 29295) | 1 | ea |
| 12-5 | | | | LO-FC2922E | | RETAINER, piston return spring | 1 | ea |
| 12-5 | | 2530-359-0816 | G740-7697473 | LO-FC11067 WO-647282 | 7697473 | ROD, push | 1 | ea |
| 12-5 | | 2530-378-7735 | 9240-FC6010 | LO-FC6010 WO-637583 | | SEAT, check | 1 | ea |
| 12-7 | | | G758-8329668 | WO-806162 | 8329668 | SHIELD, assy (welded) | 1 | ea |
| 12-7 | H1 | | H101-9409116 | | 9409116 | BOLT, machine, hex-hd, w/spring lock washer, S, cd- or zn-pltd, 3/8-24NF-2 x 2 3/4 in. | 1 | ea |
| 12-7 | H1 | 5310-012-0394 | H001-7043741 | | 120394 | WASHER, FLAT, light series, S, cd- or zn-pltd, 3/8 in. | 1 | ea |
| 12-5 | H1 | 5310-012-0395 | H001-7043771 | | 120395 | WASHER, FLAT, light series, S, cd- or zn-pltd, 1/6 in. | 1 | ea |
| | | | G758-8331874 | LO-FC11471 | 8331874 | SPRING, piston return | 1 | ea |
| | | | G740-7418140 | LO-FC11473 WO-647492 | 7418140 | SPRING, piston return, w/RETAINER and check VALVE, assy | 1 | ea |
| 12-5 | | | | LO-FE2693 WO-643671 | | TANK, supply (used w/CYLINDER 7416524) | 1 | ea |
| | | | | LO-FE3111 WO-800023 | | TANK, supply (used w/CYLINDER 7697478) | 1 | ea |
| 12-5 | | | | LO-FC11432A WO-811645 | | VALVE, check, piston return spring | 1 | ea |
| | | | | LO-FC14442 WO-119287 | | VALVE, w/SEAT, assy | 1 | ea |
| 12-5 | | 5310-737-2318 | G503-7372318 | LO-FC14297 WO-637597 | 7372318 | WASHER, flat, piston | 1 | ea |
| 12-5 | | 736-2371 | G503-7362371 | LO-FC2927 WO-637598 | 7362371 | RING, locking | 1 | ea |
| 1204.3—WHEEL CYLINDERS | | | | | | | | |
| | | 2530-734-8609 | G740-7348609 | LO-FC13090 WO-802550 | 7348609 | BOOT, front wheel cylinder (1 in.) | 4 | ea |
| 12-6 | | 2530-734-8610 | G740-7348610 | LO-FC13091 WO-802551 | 7348610 | BOOT, rear wheel cylinder (0.75 in.) | 4 | ea |
| | | 2530-773-5312 | G085-7735312 | LO-FC1499 WO-637579 | 7735312 | CUP, front wheel cylinder | 4 | ea |
| 12-6 | | 2530-734-8852 | G503-7348852 | LO-FC4158 WO-A6116 | 7348852 | CUP, rear wheel cylinder | 4 | ea |

| | | | | | | | | | |
|---------------------|----|---------------|--------------|--------------------------------------|---------|---|---|----|--|
| | | | | LO-FD7378 WO-A1737 | | CYLINDER, front wheel..... | 2 | ea | |
| | | | G758-8328442 | BX-303141 | 8328442 | CYLINDER, front wheel, assy..... | 2 | ea | |
| 12-6 | | | | LO-FD16534 WO-807356 | | | | | |
| | | | | LO-FD7544 WO-A6112 | 8677097 | CYLINDER, rear wheel brake..... | 2 | ea | |
| 12-4, 6 | | | G758-8328443 | BX-303142 LO-FD16535 WO-807357 | 8328443 | CYLINDER, rear wheel, assy..... | 2 | ea | |
| 12-4 | H1 | 042-3553 | H101-0423553 | | 423553 | BOLT, INTEGRAL LOCK WASHER, ext-teeth type, hex-hd, S, cd- or zn-pltd, 1/4-20NC-2 x 3/8 | 8 | ea | |
| | | | | LO-FC10311 WO-642014 | | INSERT, shoe guide (front wheel cylinder)..... | 4 | ea | |
| | | | | LO-FC12416 | | INSERT, shoe guide (rear wheel cylinder)..... | 4 | ea | |
| | | | G740-7697459 | LO-FC5889 WO-637578 | 7697459 | PISTON, front wheel cylinder..... | 4 | ea | |
| | | | G758-8328444 | LO-FC10310 WO-642013 | 8328444 | PISTON, front wheel cylinder, assy..... | 4 | ea | |
| | | | G740-7697460 | LO-FC8776 WO-A6114 | 7697460 | PISTON, rear wheel cylinder..... | 4 | ea | |
| 12-6 | | | G758-8328445 | LO-FC16536 WO-807411 | 8328445 | PISTON, rear wheel cylinder, assy..... | 4 | ea | |
| 12-6 | | 2510-737-2838 | G740-7372838 | LO-FC5999A WO-637539 | 7372838 | SEAT, tube, front and rear wheel cylinder..... | 4 | ea | |
| | | | G740-7697461 | LO-FC3024B WO-639949 | 7697461 | SPRING, return, front wheel cylinder piston..... | 2 | ea | |
| 12-6 | | | G503-7371112 | LO-FC6003 WO-637545 | 7371112 | SPRING, return, rear wheel cylinder piston..... | 2 | ea | |
| 12-6 | | 2530-769-7462 | G740-7697462 | LO FC12411 WO-648674 | 7697462 | VALVE, bleeder, wheel cylinder, hydraulic brake..... | 4 | ea | |
| 1204.5—LINES | | | | | | | | | |
| 11-2 | | | | SP-18602 WO-802509 | 8677054 | BRACKET, rear axle line tee..... | 1 | ea | |
| 12-7 | | 5340-737-2833 | G740-7372833 | WO-A1378 | 7372833 | CLAMP, closed, 5/16 in. line..... | 2 | ea | |
| | H4 | | H104-0126166 | | 126166 | CLIP, closed, S, cd- or zn-pltd, 1/4 OD tube, hole for 3/8 bolt (brake line under rear axle cover bolt) | 1 | ea | |
| 12-8 | H4 | | H104-0140776 | | 140776 | CLIP, closed, S, phos-ctd, 1/4 OD tube, hole for 5/16 bolt (1) superseded by CLIP 125912 for M38A1) (brake tube to rear axle) | 2 | ea | |
| 12-7 | H4 | | H104-0125912 | | 125912 | CLIP, closed, S, cd- or zn-pltd, 1/4 OD tube, hole for 5/16 bolt (supersedes (1) CLIP 140776 for M38A1) (brake tube to rear axle) | 1 | ea | |
| 12-7 | | 2530-371-4134 | G085-7735289 | WO-637427 | 7735289 | CLIP, lock, hose to bracket..... | 6 | ea | |

1204.5

| (1) ILLUSTRATION NO. | (2) REFER- ENCE SYMBOLS | (3) FEDERAL STOCK NO. | (4) ORDNANCE STOCK NO. | (5) MFR'S PART NO. | (6) ORDNANCE PART NO. | (7) DESCRIPTION | (8) QUANTITY INCOR- PORATED IN UNIT | (9) UNIT OF ISSUE |
|----------------------------------|----------------------------------|-----------------------------|------------------------------|-----------------------|-----------------------------|--|---|----------------------------|
| GROUP 12—BRAKES—Continued | | | | | | | | |
| 1204.5—LINES—Continued | | | | | | | | |
| | H4 | | H104-0432666 | | 432666 | CLIP, type E, S, phos-ctd, $\frac{3}{16}$ in (brake tubes to frame) (superseded by CLIP 145409) | 4 | ea |
| 12-7, 8 | H4 | | H104-0145409 | | 145409 | CLIP, tube, $\frac{3}{16}$ (brake tubes to frame) (supersedes CLIP 432666, M38A1) (4 used on M38A1) (5 used on M170) | 5 | ea |
| 12-7 | | 2530-495-8677 | G740-7372834 | WO-637426 | 7372834 | GASKET, cop, brake line tee fitting | 2 | ea |
| 10-4 | | 2530-703-2625 | G740-7032625 | SP-18590 WO-802298 | 7032625 | GUARD, front flexible line | 2 | ea |
| 12-7 | | 2530-737-2835 | G740-7372835 | WO-800896 | 7372835 | LINE, flex, front axle tee to master cylinder line, assy (11 in. lg) | 1 | ea |
| 12-7 | | 2530-737-2836 | G740-7372836 | WO-800953 | 7372836 | LINE, flex, left and right, front brake, assy (6 in. lg) | 2 | ea |
| 12-7 | | 2530-737-2837 | G740-7372837 | WO-800952 | 7372837 | LINE, flex, rear axle tee to master cylinder line, assy (15 in. lg) | 1 | ea |
| 12-7 | | | | WO-801393 | 8677344 | LINE, front axle tee to left flex line, assy Composed of: | 1 | ea |
| | | | | | 142431 44-T-5080- 10 | 2 NUT 1 TUBE | | |
| 12-7 | | | | WO-806163 | 8677426 | LINE, front axle tee to master cylinder, assy Composed of: | 1 | ea |
| | | | | | 137396 44-T-5080- 10 | 2 NUT 1 TUBE | | |
| 12-7 | | | | WO-801394 | 8677345 | LINE, front axle tee to right flex line, assy Composed of: | 1 | ea |
| | | | | | 142431 44-T-5080- 10 | 2 NUT 1 TUBE (33 $\frac{1}{8}$ in.) | | |
| 12-7 | | 2530-368-4866 | G503-7371009 | WO-A1488 | 7371009 | LINE, front brake cylinder to flex line, assy Composed of: | 1 | ea |
| | | | | | 142431 44-T-5080- 10 | 2 NUT 1 TUBE | | |
| 12-8 | | | | WO-808905 | | LINE, master cylinder rear, assy (M170) Composed of: | 1 | ea |
| | | | | | 142431 44-T-5080- 10 | 2 NUT 1 TUBE (87.5 in.) | | |

248

| | | | | | | | | |
|---------|----|---------------|--------------|-----------|--------------|---|----|----|
| 12-7 | | | | WO-806721 | 8677618 | LINE, master cylinder to rear flex line, assy (M38A1)..... | 1 | ea |
| | | | | | 142431 | Composed of: | | |
| | | | | | 44-T-5080-10 | 2 NUT | | |
| | | | | | | 1 TUBE (62 $\frac{9}{16}$) | | |
| | | | | WO-640942 | 8673473 | LINE, rear axle tee to left brake cylinder, assy..... | 1 | ea |
| | | | | | 142431 | Composed of: | | |
| | | | | | 44-T-5080-10 | 2 NUT | | |
| | | | | | | 1 TUBE (27 $\frac{1}{2}$ in.) (superseded by LINE WO-905857) | | |
| 12-7-8 | | | | WO-905857 | | LINE, rear axle tee to left brake cylinder, assy..... | 1 | ea |
| | | | | | 142431 | Composed of: | | |
| | | | | | 44-T-5080-10 | 2 NUT | | |
| | | | | | | 1 TUBE (25 in.) (supersedes LINE 8673473) | | |
| | | | | WO-640943 | 8673474 | LINE, rear axle to right brake cylinder, assy..... | 1 | ea |
| | | | | | 142431 | Composed of: | | |
| | | | | | 44-T-5080-10 | 2 NUT | | |
| | | | | | | 1 TUBE (30 $\frac{3}{32}$ in.) (superseded by LINE WO-905858) | | |
| 12-7, 8 | | | | WO-905858 | | LINE, rear axle to right brake cylinder, assy..... | 1 | ea |
| | | | | | 142431 | Composed of: | | |
| | | | | | 44-T-5080-10 | 2 NUT | | |
| | | | | | | 1 TUBE (25 in.) (supersedes LINE 8673474) | | |
| | H6 | 014-2431 | H006-0230209 | | 142431 | NUT, inverted flared tube coupling, br, plain, $\frac{3}{8}$ -24NF-2 | 14 | ea |
| | | | | | | x $\frac{5}{32}$, male end (optional w/NUT, 137396) | | |
| | H6 | 013-7396 | H006-0230308 | | 137396 | NUT, inverted flared tube fitting, S, cd- or zn-pltd, $\frac{3}{8}$ - | 14 | ea |
| | | | | | | 24NF-2 x $\frac{5}{32}$ (optional w/NUT 142431) | | |
| 12-7 | | | G740-7418146 | WO-804201 | 7418146 | RING, RETAINING, brake tubing (front (2), rear (1)).... | 3 | ea |
| 12-7 | | 2530-737-2839 | G740-7372839 | WO-649859 | 7372839 | TEE, front axle..... | 1 | ea |
| 12-7 | H1 | 042-3555 | H101-0423555 | | 423555 | BOLT, INTEGRAL LOCK WASHER, ext-teeth, hex- | 1 | ea |
| | | | | | | hd, S, cd- or zn-pltd, $\frac{1}{4}$ -20NC-2 x $1\frac{1}{8}$ | | |
| 12-7 | | 4730-737-2343 | G503-7372343 | LO-FC5778 | 7372343 | TEE, rear axle..... | 1 | ea |
| | | | | WO-637432 | | | | |
| 12-7 | H1 | 018-7263 | H101-0187263 | | 187263 | BOLT, hex-hd, integral lock washer, ext-teeth, S, cd- | 1 | ea |
| | | | | | | or zn-pltd, $\frac{1}{4}$ -20NC-2 x $\frac{7}{8}$ | | |
| | H7 | | H007-0218040 | | 44-T-5080-10 | TUBING, cop, seamless, soft, anld, size $\frac{3}{16}$, 0.188 OD, | † | ft |
| | | | | | | thk of wall 0.035 | | |
| | | | | | | 1206-PEDAL AND CONNECTIONS | | |
| 02-2 | | | G740-7372840 | WO-801664 | 7372840 | BEARING, PLAIN, SLEEVE, shaft retainer bracket..... | 2 | ea |
| | | | | WO-801663 | 8673316 | BRACKET, shaft retainer..... | 1 | ea |
| 12-7 | | 2530-769-7452 | G740-7697452 | WO-801662 | 7697452 | BRACKET, shaft retainer, w/BUSHING, assy..... | 1 | ea |
| 12-7 | H1 | 012-3534 | H001-5421281 | | 123534 | BOLT, mach, hex-hd, S, cd- or zn-pltd, $\frac{3}{8}$ -24NF-3 x | 3 | ea |
| | | | | | | $1\frac{1}{8}$ | | |
| 12-7 | H1 | 050-3351 | H001-4040541 | | 503351 | NUT, self-lkg, hex, S, cd- or zn-pltd, $\frac{3}{8}$ -24NF-3..... | 3 | ea |

| (1) | (2) | (3) | (4) | (5) | (6) | (7) | (8) | (9) |
|---|-------------------|-------------------|--------------------|----------------|-------------------|---|-------------------------------|---------------|
| ILLUSTRATION NO. | REFERENCE SYMBOLS | FEDERAL STOCK NO. | ORDNANCE STOCK NO. | MFR'S PART NO. | ORDNANCE PART NO. | DESCRIPTION | QUANTITY INCORPORATED IN UNIT | UNIT OF ISSUE |
| GROUP 12—BRAKES—Continued | | | | | | | | |
| 1206—PEDAL AND CONNECTIONS—Continued | | | | | | | | |
| | H16 | 050-4208 | H016-0504208 | | 504208 | FITTING, lubr, hyd type, S, cd- or zn-pltd, male thread, 1/8-27NPT, ball check valve | 3 | ea |
| 12-7 | | 2530-769-7466 | G740-7697466 | WO-807327 | 8673366 | PAD | 1 | ea |
| 12-7 | H1 | | H101-9409103 | WO-807329 | 7697466 | PAD, assy | 1 | ea |
| | | | | | 9409103 | BOLT, MACHINE, hex-hd, w/spring lock washer, S, cd or zn-pltd, 5/16-18NC-2 x 1 1/4 | 1 | ea |
| 12-7 | | | G750-8328436 | WO-807208 | 8328436 | PAD, shank (superseded by PAD WO-906638) | 1 | ea |
| | | | | WO-906638 | | PAD, shank (supersedes PAD 8328436) | 1 | ea |
| | | | | WO-647634 | 8673397 | PEDAL, brake (optional w/PEDAL 8673482) | 1 | ea |
| | | | | WO-647635 | 8673482 | PEDAL, brake (optional w/PEDAL 8673397) | 1 | ea |
| 12-7; 18-6 | | | G740-7697453 | WO-800527 | 7697453 | PEDAL, brake, assy | 1 | ea |
| 12-7 | H1 | 013-7228 | H101-0137228 | | 137228 | PIN, cotter, split, S, pltd, 5/32 x 1 1/2 (brake pedal shaft) | 1 | ea |
| 02-2; 12-7 | | 2530-734-0237 | G503-7340237 | WO-A495 | 7340237 | SHAFT, pedal (welded) | 1 | ea |
| 12-7 | | | G503-8387940 | WO-630593 | 8387940 | SPRING, retracting | 1 | ea |
| 12-7 | | 5340-769-7454 | G740-7697454 | WO-650684 | 7697454 | SPRING, shank pad | 1 | ea |
| 12-7 | | 5310-456-6298 | G740-7372827 | WO-A498 | 7372827 | WASHER, FLAT, sp, S, 1 1/32 ID, 1 1/2 OD, x 1/8 thk (shaft) | 1 | ea |
| | | | G740-7375065 | WO-A6360 | 7375065 | WASHER, FLAT, S, 1 1/32 ID, 1 3/4 OD, 0.0747 thk (brake pedal shank draft pad) (superseded by WASHER 7954265) | 1 | ea |
| 12-7 | | | | WO-641929 | 7954265 | WASHER, FLAT, S, cd-pltd, 1 1/32 ID, 1 3/4 OD, 0.0747 thk (brake pdeal shank draft pad) (supersedes WASHER 7375065) | 1 | ea |
| GROUP 13—WHEELS, HUBS, AND DRUMS | | | | | | | | |
| 1311—WHEELS, HUBS, AND DRUMS | | | | | | | | |
| 10-4, 6; 11-4 | | 2530-737-5143 | G740-7375143 | WO-800798 | 7375143 | CAP, hub | 4 | ea |
| 10-4, 6 | H12 | 100-3526 | H012-6141280 | | 705423 | CONE, tapered roller bearing, MIL-STD-CODE 711-18590-3000 (includes rollers and cage, SR, 1.6250 bore, 0.6875 width) (front axle) | 4 | ea |
| 11-4 | H12 | | H012-6149800 | | 705447 | CONE, tapered roller bearing, MIL-STD-CODE 711-25877-3000 (includes rollers and cage, SR, 1.3750 bore, 0.9688 width) (rear axle) | 2 | ea |
| 10-4, 6 | H12 | | H012-6219420 | | 706836 | CUP, tapered roller bearing, MIL-STD-CODE 711-18520-1000 (SR, 2.8750 OD, 0.5000 width) (front axle) | 4 | ea |

251

1311

| | | | | | | | | |
|------------|-----|---------------|--------------|---|---------|--|----|----|
| 11-4 | H12 | | H012-6221700 | | 706857 | CUP, tapered roller bearing, MIL-STD-CODE 711-25821-1000 (SR, 2.8750 OD, 0.7500 width) (rear axle) | 2 | ea |
| | | 2530-737-5139 | G740-7375139 | KHW-33547 WO-649875 MW-33596 | 7375139 | DRUM, brake, front and rear semi-finished (optional w/DRUM MW-33596) | 4 | ea |
| | | | | WO-808595 | | DRUM, brake, front and rear semi-finished (optional w/DRUM 7375139) | 4 | ea |
| 10-6; 11-4 | | | G747-7328371 | KHW-36567 WO-808769 MW-3396A WO-808770 | 7328371 | DRUM, brake, front and rear finished (optional w/DRUM MW-33596 or 7375139) | 4 | ea |
| 10-6; 11-4 | H11 | 5305-013-7991 | H101-0137991 | | 137991 | BOLT, MACHINE, fl-hd, S, cd- or zn-pltd, 1/4"-20NC-2 x 1 1/16" | 12 | ea |
| | | | | WO-636372 | 8393111 | GASKET, axle shaft grease retainer (felt) (superseded by GASKET WO-646238) | 2 | ea |
| | | | | WO-646238 | | GASKET, felt and ru, 1 15/16" ID, 2 1/16" OD, 1/16" thk (supersedes GASKET 8393111) | 2 | ea |
| | | 2530-732-8291 | G747-7328291 | KHW-33544 WO-649873 | 7328291 | HUB, front, left, w/brake DRUM, assy..... | 1 | ea |
| | | 2530-732-8292 | G747-7328292 | KHW-33545 WO-649874 | 7328292 | HUB, front, right, w/brake DRUM, assy..... | 1 | ea |
| | | | | KHW-33706 WO-801707 | 8673315 | HUB, rear, left, w/brake DRUM, assy..... | 1 | ea |
| | | | | KHW-33705 WO-801708 | | HUB, rear, right, w/brake DRUM, assy..... | 1 | ea |
| | | | G758-8333378 | KHW-34123 WO-909548 | 8333378 | HUB, w/bearing CUPS, assy..... | 1 | ea |
| 10-6 | | 2530-737-5142 | G740-7375142 | KHW-33546 | 7375142 | HUB, wheel, front, left and right (w/o CUPS and STUDS) | 2 | ea |
| | | 2530-352-6961 | G747-7328376 | KHW-33553 WO-649937 | 7328376 | HUB, wheel, front, left, assy..... | 1 | ea |
| | | | | | 706836 | Composed of: 2 CUP | | |
| | | | | | 7375142 | 1 HUB | | |
| | | | | | 7328294 | 5 STUD | | |
| | | 2530-352-6960 | G747-7328375 | KHW-33552 WO-649938 | 7328375 | HUB, wheel, front, right, assy..... | 1 | ea |
| | | | | | 706836 | Composed of: 2 CUP | | |
| | | | | | 7375142 | 1 HUB | | |
| | | | | | 7328293 | 5 STUD | | |
| | | 2530-737-5144 | G740-7375144 | KHW-33707 WO-801709 | 7375144 | HUB, wheel, rear, left and right unpainted, less CUPS and STUDS (optional w/HUB 8333106) | 2 | ea |
| 11-4, 6 | | | G758-8333106 | KHW-34082 WO-811351 | 8333106 | HUB, wheel, rear, left and right painted olive drab, less CUPS and STUDS (optional w/HUB 7375144) | 2 | ea |
| 10-4, 6 | | | G503-7371106 | SP-17016 WO-A866 | 7371106 | NUT, hex, S, 1 5/8"-16 (wheel bearing front axle)..... | 4 | ea |
| 10-6 | | | G758-8329732 | WO-804821 | 8329732 | SEAL, front hub cap..... | 2 | ea |
| 10-4, 6 | H13 | | H013-8329731 | | 8329731 | SEAL, oil, front hub..... | 2 | ea |

| (1) | (2) | (3) | (4) | (5) | (6) | (7) | (8) | (9) |
|------------------|-------------------|-------------------|--------------------|------------------------|-------------------|--|-------------------------------|---------------|
| ILLUSTRATION NO. | REFERENCE SYMBOLS | FEDERAL STOCK NO. | ORDNANCE STOCK NO. | MFR'S PART NO. | ORDNANCE PART NO. | DESCRIPTION | QUANTITY INCORPORATED IN UNIT | UNIT OF ISSUE |
| | | | | | | GROUP 13—WHEELS, HUBS, AND DRUMS—Continued | | |
| | | | | | | 1311—WHEELS, HUBS, AND DRUMS—Continued | | |
| | | 5330-737-5137 | G740-7375137 | WO-640885 | 7375137 | SEAL, PLAIN, ENCASED, grease, axle shaft, (superseded by SEAL 8332519) | 2 | ea |
| 11-4 | | | G758-8332519 | WO-646239 | 8332519 | SEAL, PLAIN, ENCASED, grease, axle shaft, assy (supersedes SEAL 7375137) | 2 | ea |
| 10-4, 6 | | 5310-769-6521 | G503-7696521 | SP-17017 WO-A867 | 7696521 | WASHER, KEY, lock, S, 1 ¹ / ₆₄ (front axle wheel bearing nut) | 2 | ea |
| 10-4, 6 | | 5310-769-6520 | G503-7696520 | SP-17015 WO-A865 | 7696520 | WASHER, KEY, lock, S, 1 ¹ / ₆₄ (front axle wheel bearing) | 2 | ea |
| 15-3 | | | G503-7387807 | KHW-33702 WO-801762 | 7387807 | WHEEL, assy (16 x 4.50) | 5 | ea |
| 15-3 | H14 | | H014-5232405 | | 5232405 | NUT, CONE SEAT, HEX, S, 1/2-20NF-2, RH thd, wheel stud (front and rear (10) spare wheel (3)) | 13 | ea |
| 10-6 | H14 | | H014-5232404 | | 5232404 | NUT, CONE SEAT, HEX, S, 1/2-20NF-2 (LH thd, wheel stud) (grooved head) | 10 | ea |
| | H14 | 5305-732-8294 | H014-7328294 | | 7328294 | STUD, BOLT, RIBBED SHOULDER, 1/2-20NF-3 x 1.42, left thd (wheel hub, front) | 10 | ea |
| 11-4 | H14 | 5305-732-8293 | H014-7328293 | | 7328293 | STUD, BOLT, RIBBED SHOULDER, 1/2-20NF-3 x 1.42 right thd (front and rear) | 10 | ea |
| | | | | | | 1313—TIRES AND TUBES | | |
| | H14 | 052-0944 | H014-0520944 | | 520944 | CAP, TIRE VALVE, screwdriver type | 5 | ea |
| | H14 | 050-1229 | H014-0501229 | | 501229 | CORE, VALVE, TIRE | 5 | ea |
| | H14 | | H014-0520894 | | 520894 | SLEEVE, tire valve mtg (for valves of 6.00-16 tubes when mtd w/BEADLOCKS) (use on vehicles through serial no. 83569) | 5 | ea |
| | | | | WO-801899 | 8677073 | TIRE, pneumatic, 7.00-16, 6-ply, w/TUBE 7.00-16, assy (optional w/TIRE 8676975) | 5 | ea |
| | | | | WO-800044 | 8676975 | TIRE, pneumatic, 7.00-16, 6-ply, cross-country tread, w/TUBE 7.00-16, assy (optional w/TIRE 8677073) | 5 | ea |
| | H14 | 2610-269-9586 | H014-0511830 | | 511830 | TIRE, PNEUMATIC, truck and bus, 6-ply, cross-country tread, 7.00-16 (new) (optional w/TIRE 8677074) | 5 | ea |
| | | | | WO-801900 | 8677074 | TIRE, pneumatic, truck and bus, 6-ply, cross-country tread, block, 7.00-16 (new) (optional w/TIRE 511830) | 5 | ea |
| | H14 | 2610-269-7332 | H014-0519252 | | 519252 | TUBE, INNER, PNEUMATIC TIRE, truck and bus, 7.00-16 (new) (optional w/TUBE 8677075) | 5 | ea |
| | | | | WO-801901 | 8677075 | TUBE, pneumatic tire, truck and bus, 7.00-16 (new) (optional w/TUBE 519252) | 5 | ea |

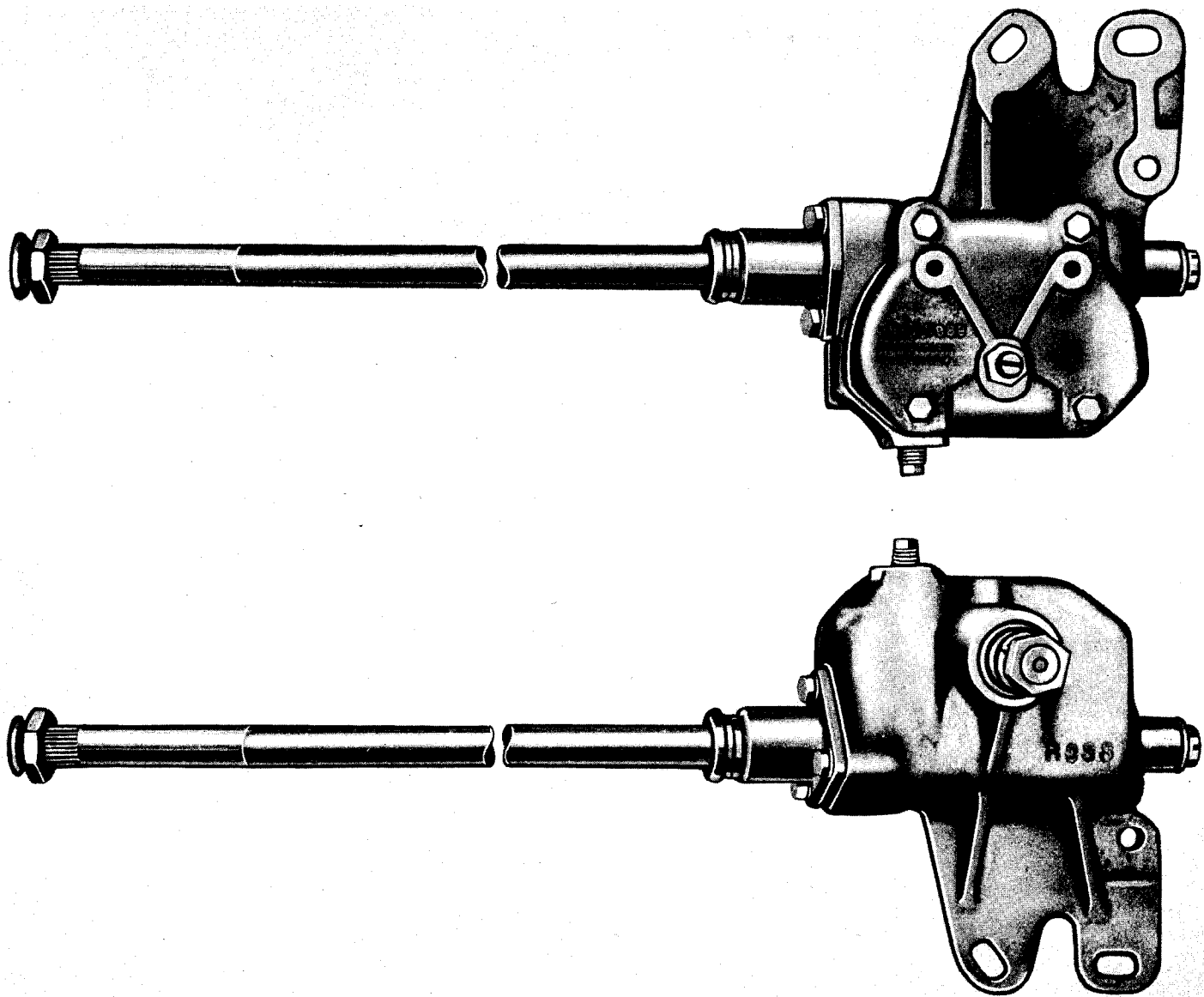

RA PD 181654

Figure 14-1. Steering gear, assy (8332549)

| KEY | ITEM | PART NO | GROUP |
|-----|--------------|-----------|-------|
| A | SWITCH, ASSY | 8329689 | 0611 |
| B | GASKET | 8329688 | 0611 |
| C | ADAPTER | RG-402141 | 0611 |
| D | HOUSING | 8677628 | 1401 |
| E | NUT | 124949 | 1401 |
| F | WASHER | 131046 | 1401 |
| G | ARM | 7412445 | 1401 |
| H | SEAL | 7375341 | 1401 |
| J | BEARING | 7375348 | 1401 |
| K | BEARING | 7375349 | 1401 |
| L | PLUG | 103866 | 1401 |
| M | TUBE | 7375337 | 1401 |
| N | RING | 7696371 | 1401 |
| P | CUP | 7367859 | 1401 |
| Q | BALL | 104919 | 1401 |
| R | SHAFT, ASSY | 8329730 | 1401 |
| S | GASKET | 7412577 | 1401 |
| T | SHIM | 7696350 | 1401 |
| U | COVER | RG-126023 | 1401 |
| V | WASHER | 120638 | 1401 |
| W | SCREW | 214644 | 1401 |
| X | SEAL | 8332551 | 1401 |
| Y | WHEEL | 7375336 | 1401 |
| Z | NUT | 7412579 | 1401 |

NOTE: ITEM R INCLUDES NUT—
7412579

1 1/16 1/8 3/16 1/4 5/16 3/8
INCHES

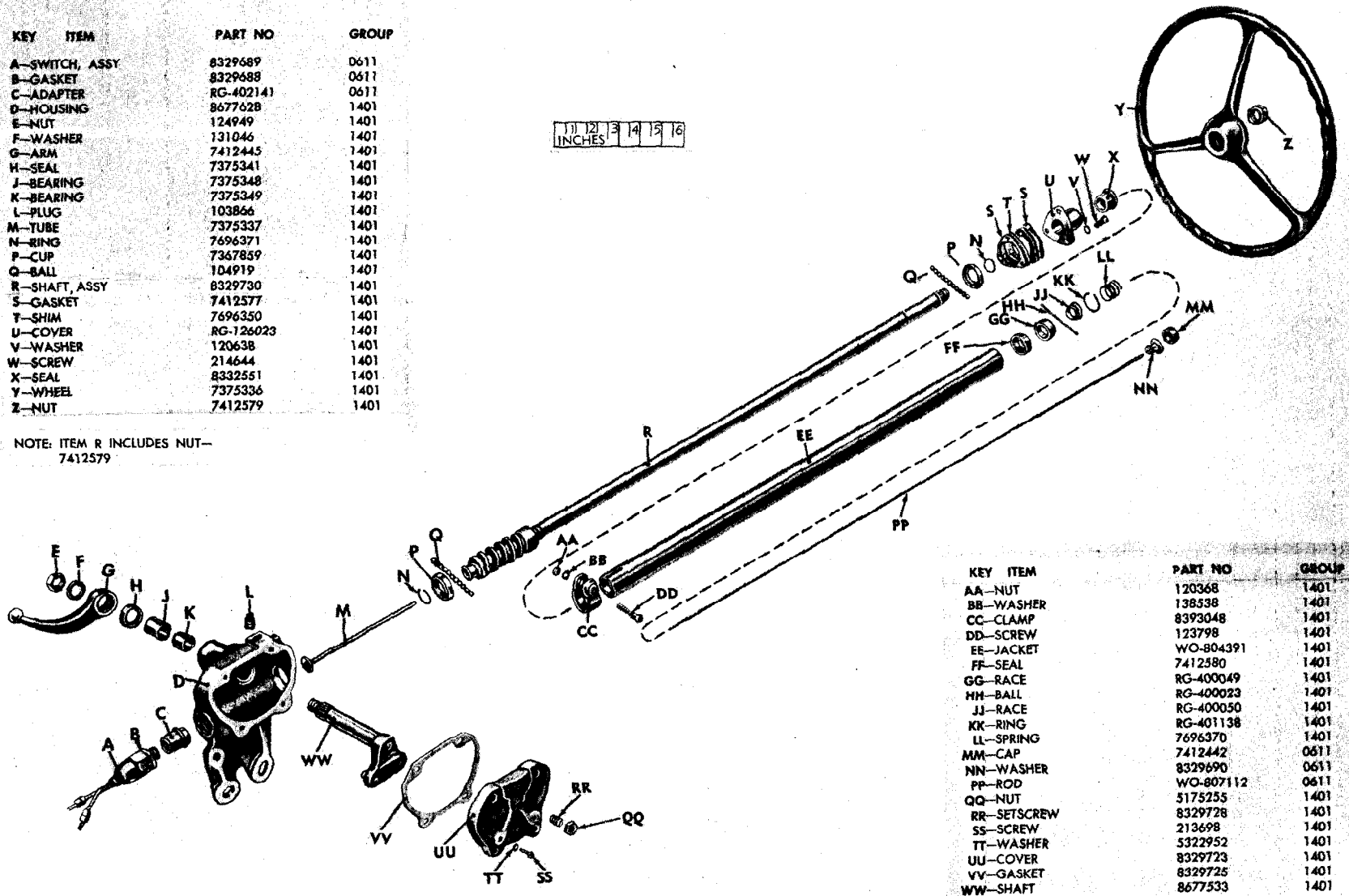

| KEY | ITEM | PART NO | GROUP |
|-----|----------|-----------|-------|
| AA | NUT | 120368 | 1401 |
| BB | WASHER | 138538 | 1401 |
| CC | CLAMP | 8393048 | 1401 |
| DD | SCREW | 123798 | 1401 |
| EE | JACKET | WO-804391 | 1401 |
| FF | SEAL | 7412580 | 1401 |
| GG | RACE | RG-400049 | 1401 |
| HH | BALL | RG-400023 | 1401 |
| JJ | RACE | RG-400050 | 1401 |
| KK | RING | RG-401138 | 1401 |
| LL | SPRING | 7696370 | 1401 |
| MM | CAP | 7412442 | 0611 |
| NN | WASHER | 8329690 | 0611 |
| PP | ROD | WO-807112 | 0611 |
| QQ | NUT | 5175235 | 1401 |
| RR | SETScrew | 8329728 | 1401 |
| SS | SCREW | 213698 | 1401 |
| TT | WASHER | 5322952 | 1401 |
| UU | COVER | 8329723 | 1401 |
| VV | GASKET | 8329725 | 1401 |
| WW | SHAFT | 8677533 | 1401 |

RA PD 367245

Figure 14-2. Steering gear and related parts—exploded view

| KEY ITEM | PART NO |
|----------|---------|
| A—PIN | 137214 |
| B—PLUG | 8677061 |
| C—SEAT | 7036567 |
| D—SPRING | 7036587 |
| E—SEAT | 7036588 |
| F—PLUG | 8676987 |

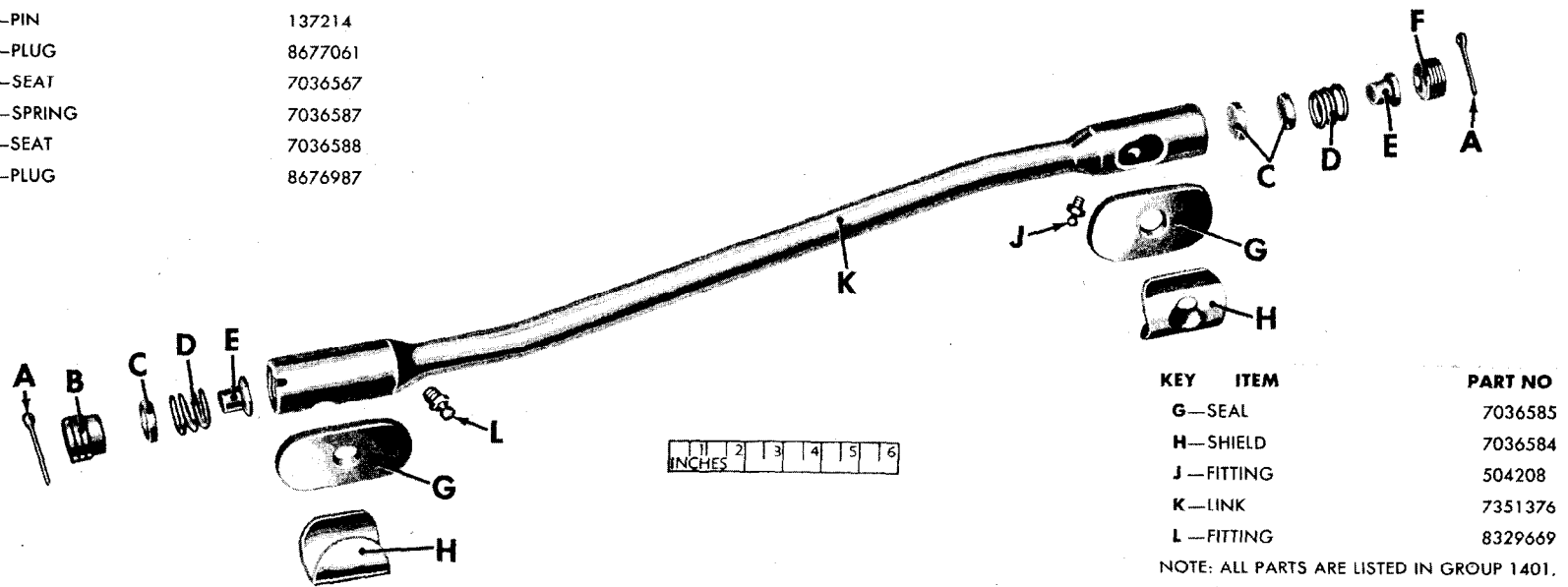

| KEY ITEM | PART NO |
|-----------|---------|
| G—SEAL | 7036585 |
| H—SHIELD | 7036584 |
| J—FITTING | 504208 |
| K—LINK | 7351376 |
| L—FITTING | 8329669 |

NOTE: ALL PARTS ARE LISTED IN GROUP 1401.

RA PD 367159

Figure 14-3. Drag link—exploded view

| KEY ITEM | PART NO. |
|-------------|------------|
| A—PIN | 137168 |
| B—NUT | 125250 |
| C—SPRING | 7373111 |
| D—COVER | 8393055 |
| E—END, ASSY | 8329742 |
| F—NUT | 121949 |
| G—WASHER | 120383 |
| H—TUBE | SP-30067-2 |
| J—FITTING | 8329748 |
| K—END, ASSY | 8329744 |
| L—TUBE | 8677519 |
| M—END, ASSY | 8329743 |
| N—SCREW | 181673 |
| P—CLAMP | 8329741 |

NOTE: ALL PARTS LISTED ABOVE
ARE IN GROUP 1401

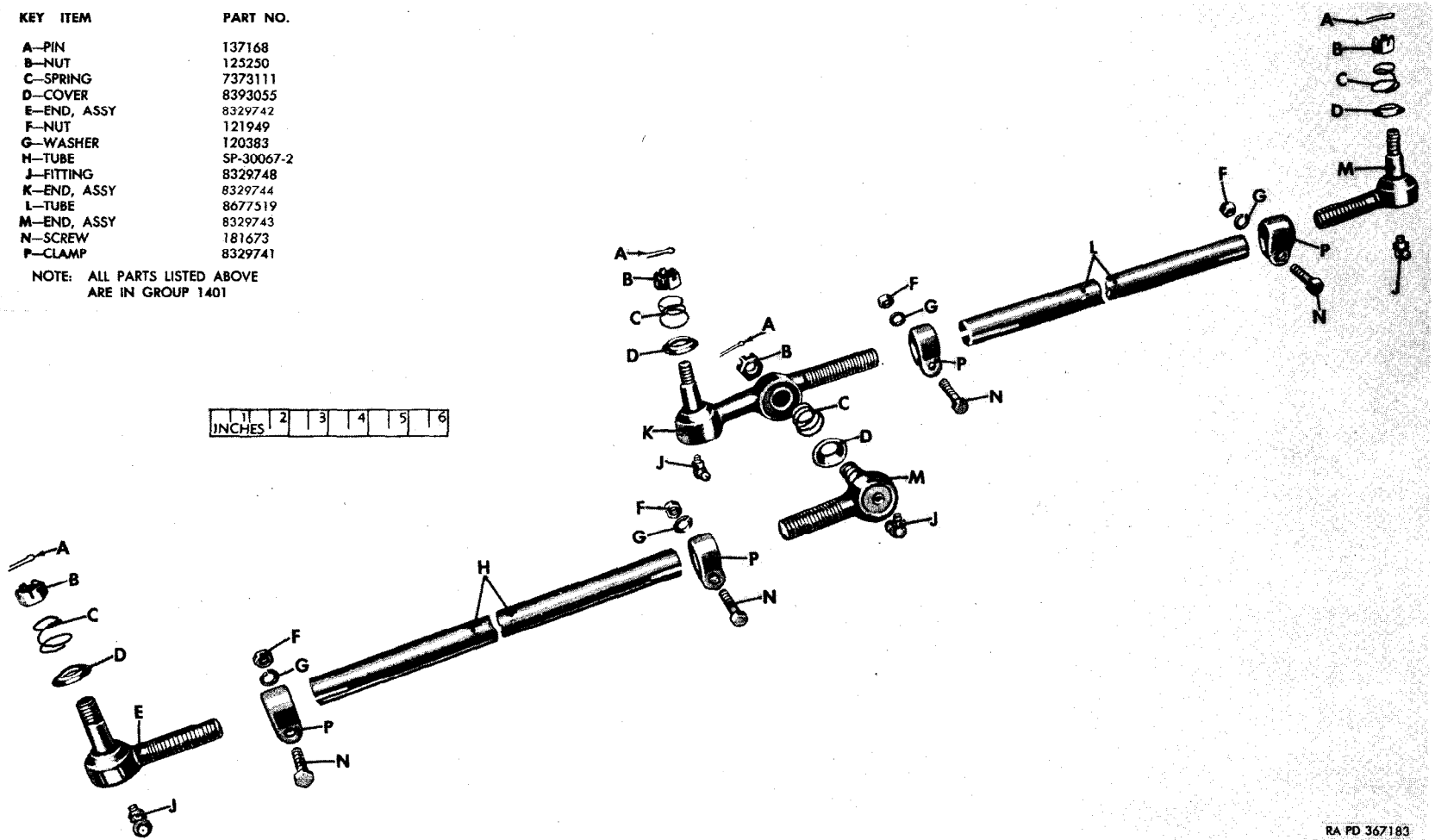

256

RA PD 367183

Figure 14-4. Steering tie rod—exploded view

| (1) ILLUSTRATION NO. | (2) REFER- ENCE SYMBOLS | (3) FEDERAL STOCK NO. | (4) ORDNANCE STOCK NO. | (5) MFR'S PART NO. | (6) ORDNANCE PART NO. | (7) DESCRIPTION | (8) QUANTITY INCOR- PORATED IN UNIT | (9) UNIT OF ISSUE |
|-------------------------------|----------------------------------|--------------------------------|------------------------------|--|-----------------------------|--|---|----------------------------|
| GROUP 14—CONTROLS | | | | | | | | |
| 1401—STEERING CONTROLS | | | | | | | | |
| 14-2 | | 2530-741-2445 | G740-7412445 | WO-804535 | 7412445 | ARM, Pitman..... | 1 | ea |
| 14-2 | H2 | | H002-0100130 | | 104919 | BALL, S, gr 2, 5/16 in. (cam thrust bearing)..... | 22 | ea |
| 14-2 | | | | RG-400023 | | BALL, steering column bearing..... | 22 | ea |
| | H12 | | H012-7375185 | | 7375185 | BEARING, bushing type, bellcrank pivot shaft inner race spacer, 0.8750 ID, 1.1260 OD, 1.636 lg | 1 | ea |
| 14-2 | | 3120-737-5349 | G740-7375349 | RG-064003 WO-647099 | 7375349 | BEARING, bushing type, Pitman shaft inner (in housing) | 1 | ea |
| | H12 | | H012-0712159 | | 712159 | BEARING, needle, open end, no inner race, 1 1/8, 1 3/8, 1/2 width (bellcrank) | 2 | ea |
| 14-2 | | 3120-737-5348 | G740-7375348 | RG-064004 WO-647098 RG-063983 WO-801422 | 7375348 8677346 | BEARING, PLAIN SLEEVE, Pitman shaft outer (in housing) | 1 | ea |
| | | | | RG-400023 RG-400049 RG-400050 RG-401138 WO-647008 WO-800867 | 8677020 7375183 | Composed of: 22 BALL 1 RACE 1 RACE 1 RING BELLCRANK, steering..... | 1 | ea |
| | H1 | 2530-737-5183 012-4145 | G740-7375183 H101-0124145 | | 7375183 124145 | BELLCRANK, steering, assy..... | 1 | ea |
| | H1 | 012-0370 | H001-4167641 | | 120370 | BOLT, mach, hex-hd, S, cd- or zn-pltd, 1/16-20NF-3 x 2 1/2 (used after vehicle serial No. 50397) | 1 | ea |
| | H1 | 012-4139 | H001-5423121 | | 124139 | NUT, plain, hex, S, cd- or zn-pltd, 1/16-20NF-2..... | 1 | ea |
| | H1 | 5310-012-0383 3120-741-6462 | H001-7025771 G503-7416462 | WO-A1277 | 120383 7416462 | SCREW, mach, hex-hd, S, cd- or zn-pltd, 1/16-20NF-3 x 2 1/4 (used through vehicle serial No. 50397) | 1 | ea |
| | | | | | | WASHER, lock, med, S, cd- or zn-pltd, 1/16 in..... | 1 | ea |
| 14-4 | | | G758-8329741 | SP-30068 WO-806746 | 8329741 | BUSHING, webbing, 5 in lg, 1 1/2 in. wide, 1/8 in. thk (jacket support clamp) | 1 | ea |
| | | | | | | CLAMP, end, tie rod..... | 4 | ea |
| 14-4 | H1 | 012-1949 | H001-4171641 | | 121949 | NUT, plain, hex, 1/16-20NF-3..... | 4 | ea |
| 14-4 | H1 | 018-1673 | H001-5457081 | | 181673 | SCREW, mach, 1/16-20NF-3 x 1 7/8..... | 4 | ea |
| 14-4 | H1 | 5310-012-0383 5340-737-5347 | H001-7025771 G740-7375347 | WO-649995 | 120383 7375347 | WASHER, lock, med, S, cd- or zn-pltd, 1/16 in..... | 4 | ea |
| | H1 | 042-5591 | H101-0425591 | | 425591 | CLAMP, jacket support..... | 1 | ea |
| | | | | | | BOLT, integral lock washer, ext-teeth, hex-hd, S, cd- or zn-pltd, 5/16-24NF-2 x 1/8 | 2 | ea |
| | H1 | 012-0368 | H001-4167561 | | 120368 | NUT, plain, hex, reg, S, 5/16-24NF-2..... | 2 | ea |

1401

| (1) | (2) | (3) | (4) | (5) | (6) | (7) | (8) | (9) |
|---|-------------------|--------------------------------|------------------------------|-------------------------------------|--------------------|--|-------------------------------|---------------|
| ILLUSTRATION NO. | REFERENCE SYMBOLS | FEDERAL STOCK NO. | ORDNANCE STOCK NO. | MFR'S PART NO. | ORDNANCE PART NO. | DESCRIPTION | QUANTITY INCORPORATED IN UNIT | UNIT OF ISSUE |
| GROUP 14—CONTROLS—Continued | | | | | | | | |
| 1401—STEERING CONTROLS—Continued | | | | | | | | |
| 14-2 | | 2530-769-6374 | G503-7696374 | RG-502282 WO-A635 | 7696374 | CLAMP, mtg, steering jacket to housing, w/BOLT, NUT, and WASHER, assy | 1 | ea |
| | | | | RG-475104 WO-A636 | 8393048 | CLAMP, steering column..... | 1 | ea |
| 14-2 | H1 | 012-0368 | H001-4167561 | | 120368 | NUT, plain, hex, reg. s-fin, S, 5/16-24NF-2..... | 1 | ea |
| 14-2 | H1 | 012-3798 | H101-0123798 | | 123798 | SCREW, machine, 5/16-24NF-3 x 1 3/4..... | 1 | ea |
| 14-2 | H1 | 013-8538 | H001-7021771 | | 138538 | WASHER, lock, int-teeth, S, cd- or zn-pltd, 5/16 in..... | 1 | ea |
| 14-4 | | | G503-8393055 | SP-16067 WO-A844 | 8393055 | COVER, grease retn, tie rod end..... | 4 | ea |
| 14-2 | | | G758-8329723 | WO-807477 WO-807475 | 8329723 8673368 | COVER, housing side..... COVER, housing side, assy..... | 1 1 | ea ea |
| | | | | | 8329723 | Composed of: | | |
| | | | | | 5175255 | 1 COVER | | |
| | | | | | 8329728 | 1 NUT | | |
| | | | | | 213698 | 1 SET SCREW | | |
| 14-2 | H1 | 021-3698 | H001-1013021 | | 5322952 | SCREW, cap, hex-hd, S, 5/16-18NC-2 x 1..... | 4 | ea |
| 14-2 | | 5310-360-7403 | G102-5322952 | RG-029021 WO-639121 | | WASHER, FLAT, br, cap, S, cd- or zn-pltd, 0.328 ID, 0.562 OD | 4 | ea |
| 14-2 | | | | RG-126023 WO-804386 | | COVER, housing upper..... | 1 | ea |
| 14-2 | H1 | 021-4644 | H101-0214644 | | 214644 | SCREW, MACHINE, shoulder, hex-hd, S, 5/16-18NC-2 x 3/4 | 3 | ea |
| 14-2 | H1 | 5310-012-0638 2530-741-2446 | H001-7018711 G740-7412446 | | 120638 | WASHER, lock, heavy, S, cd- or zn-pltd, 5/16 in..... | 3 | ea |
| | | | | RG-500824 WO-804385 | 7412446 | COVER, housing upper, w/SEAL, assy (used w/GEAR 8329724) (superseded by COVER 8332552) | 1 | ea |
| | | | | RG-126023 | | Composed of | | |
| | | | | | 8332553 | 1 COVER | | |
| | | | | | 8332552 | 1 SEAL | | |
| | | | G758-8332552 | RG-500931 WO-808442 | | COVER, housing, upper w/SEAL, assy (used w/GEAR 8332549) (supersedes COVER 7412446) | 1 | ea |
| | | | | RG-126023 | | Composed of: | | |
| | | | | | 8332551 | 1 COVER | | |
| | | | | | 7367859 | 1 SEAL | | |
| 14-2 | | | G503-7367859 | RG-400025 WO-639102 | | CUP, ball, cam shaft thrust bearing..... | 2 | ea |
| 14-4 | | | G758-8329742 | SP-20071X WO-806749 TP-SV332A | 8329742 | END, assy (lht)..... | 1 | ea |

259

| | | | | | | | | |
|------|-----|---------------|--------------|---------------------------------------|---------|--|---|----|
| 14-4 | | | G758-8329743 | SP-20070X TP-14SV331A WO-806750 | 8329743 | END, assy (rht)..... | 2 | ea |
| 14-4 | H1 | 012-5250 | H001-4217681 | | 125250 | NUT, slotted, hex, lt, s-fin, S, cd- or zn-pltd, 1/2-20NF-2 | 4 | ea |
| 14-4 | H1 | 013-7168 | H101-0137168 | | 137168 | PIN, cotter, split, S, pltd, 3/32 x 7/8 | 4 | ea |
| 14-4 | | | G758-8329744 | SP-20072X TP-14SV333A WO-806752 | 8329744 | END, tie, rod to bellcrank (lht)..... | 1 | ea |
| | | | G758-8332476 | WO-809189 | 8332476 | END, w/lubr FITTING, assy (lht)..... | 1 | ea |
| | | | G758-8332474 | WO-809190 | 8332474 | END, w/lubr FITTING, assy (lht)..... | 1 | ea |
| | | | G758-8332475 | WO-809191 | 8332475 | END, w/lubr FITTING, assy (rht)..... | 2 | ea |
| 14-3 | H16 | | H016-8329669 | | 8329669 | FITTING, lubr, hyd type, bellcrank 90 deg, 1/8NPT (drag link) | 1 | ea |
| 14-4 | | | G758-8329748 | AD-1911B WO-806430 | 8329748 | FITTING, lubr, hyd type (90 deg) 1/4-28NF male, 3/4 in. overall lg | 4 | ea |
| 14-3 | H16 | 050-4208 | H016-0504208 | | 504208 | FITTING, lubr, hyd type, S, cd- or zn-pltd, male thd, 1/8-27NPT (ball check valve) | 2 | ea |
| 14-2 | | | G758-8329725 | RG-TL129000 WO-807476 | 8329725 | GASKET, housing side cover..... | 1 | ea |
| 14-2 | | 2530-741-2577 | G740-7412577 | RG-033092 WO-804399 | 7412577 | GASKET, housing upper cover..... | 2 | ea |
| | | | G758-8329724 | WO-805676 | 8329724 | GEAR, steering, w/o steering WHEEL and Pitman ARM, assy (superseded by GEAR 8332549) | 1 | ea |
| 14-1 | | | G758-8332549 | RG-TL13019 WO-808444 | 8332549 | GEAR, steering, w/o steering WHEEL and Pitman ARM, assy. (19-17-19 ratio) (supersedes GEAR 8329724) | 1 | ea |
| | H11 | 012-0370 | H001-4167641 | | 120370 | NUT, plain, hex, 1/16-20NF-2 | 3 | ea |
| | H1 | 012-4155 | H101-0124155 | | 124155 | SCREW, CAP, HEXAGON-HEAD: low-carbon-S, cd- or zn-pltd, 1/16-20NF-2A x 3 | 3 | ea |
| | H1 | 017-8571 | H001-7124761 | | 178571 | WASHER, lock, ext-int-teeth, S, cd- or zn-pltd, 1/16 in. | 6 | ea |
| 14-2 | | | | RG-TL122003 WO-805677 | 8677628 | HOUSING..... | 1 | ea |
| | | | G758-8329726 | RG-505765 WO-807473 | 8329726 | HOUSING, assy..... | 1 | ea |
| | | | | | 7375349 | Composed of: | | |
| | | | | | 7375348 | 1 BEARING | | |
| | | | | | 8677628 | 1 BEARING | | |
| | | | | | 8329727 | 1 HOUSING | | |
| | | | | | 103866 | 1 PLUG | | |
| | | | | | 7375341 | 1 PLUG | | |
| | | | | | 8332550 | 1 SEAL | | |
| | | 2530-741-2576 | G758-8332550 | WO-809200 | 8332550 | JACKET, w/BEARING, assy (used w/GEAR 8332549) | 1 | ea |
| | | | G740-7412576 | WO-804390 | 7412576 | JACKET, w/BEARING, assy (used w/GEAR 8329724) | 1 | ea |
| 14-2 | | | | WO-804391 | | JACKET, tube (used w/GEAR 8329724) | 1 | ea |
| | | | | WO-809192 | | JACKET, tube (used w/GEAR 8332549) | 1 | ea |
| 14-3 | | | G740-7351376 | WO-646620 | 7351376 | LINK, drag..... | 1 | ea |
| | | 2530-737-5182 | G740-7375182 | CA-H11371 WO-801264 | 7375182 | LINE, drag, assy..... | 1 | ea |

| (1) ILLUSTRATION NO. | (2) REFERENCE SYMBOLS | (3) FEDERAL STOCK NO. | (4) ORDNANCE STOCK NO. | (5) MFR'S PART NO. | (6) ORDNANCE PART NO. | (7) DESCRIPTION | (8) QUANTITY INCORPORATED IN UNIT | (9) UNIT OF ISSUE |
|---|--------------------------|--------------------------|---------------------------|-------------------------------------|--|---|--------------------------------------|----------------------|
| GROUP 14—CONTROLS—Continued | | | | | | | | |
| 1401—STEERING CONTROLS—Continued | | | | | | | | |
| 14-2 | | | G102-5175255 | WO-800868 RG-021162 WO-807472 | 8677333 504208 8329669 7375182 5175255 | LINK, drag, w/FITTINGS, assy..... Composed of: 1 FITTING 1 FITTING 1 LINK | 1 | ea |
| 14-3 | | 5310-741-2579 | G740-7412579 | RG-26097 WO-801425 | 7412579 | NUT, locking, plain, hexagon, lt, s-fin, S, 1/2-20NF-2 (adj screw) | 1 | ea |
| 14-3 | | | | CA-5-11373 WO-801565 | 8677061 | NUT, SLEEVE, hex, sp, 1 1/16-20NC..... | 1 | ea |
| 14-3 | | | | CA-11372 WO-801265 | 8676987 | PLUG, adj, drag link ball seat, large..... | 1 | ea |
| 14-3 | H1 | 013-7214 | H101-0137214 | RG-402129 WO-801550 | 187214 | PLUG, adj, drag link ball seat, small..... | 1 | ea |
| 14-2 | | | | RG-9471-9 WO-806917 | 8829727 | PIN, cotter, 1/8 x 1 3/4..... | 2 | ea |
| 14-2 | | | | | | PLUG, expansion, oil seal tube (steering gear) (horn adapter)..... | 1 | ea |
| 14-2 | H6 | 010-8866 | H006-0288568 | | | PLUG, oil seal, w/ADAPTER, assy..... | 1 | ea |
| 14-2 | | | | RG-400050 | 103866 | PLUG, pipe, sq-hd, CI, 1/4-18NPT (steering gear housing)..... | 1 | ea |
| 14-2 | | | | RG-400049 | | RACE, steering column bearing, inner..... | 1 | ea |
| 14-2 | | 5340-769-6371 | G503-7696371 | RG-401100 WO-639103 | 7696371 | RACE, steering column bearing, outer..... | 1 | ea |
| 14-2 | | | | RG-401138 | | RING, retn, shaft cam thrust bearing..... | 2 | ea |
| 14-2 | | | | SP-20069X TP-14T220 WO-806372 | 8829746 | RING, steering column bearing..... | 1 | ea |
| 14-2 | | | | SP-20068X TP-14T219 WO-806371 | 8329747 | ROD, tie, steering, left, w/ENDS, assy..... | 1 | ea |
| 14-2 | | 5330-737-5181 | G740-7375181 | GPC-14982 WO-645663 | 7375181 | ROD, tie, steering, right, w/ENDS, assy..... | 1 | ea |
| 14-3 | | 5330-737-5180 | G740-7375180 | WO-801566 | 7375180 | SEAL, bellcrank..... | 2 | ea |
| 14-3 | | 2530-703-6585 | G503-7036585 | WO-A622 | 7036585 | SEAL, bellcrank to bracket (ru)..... | 1 | ea |
| 14-3 | | | | RG-032161 WO-804987 | 8332553 | SEAL, dust, drag link..... | 2 | ea |
| 14-2 | | 5330-737-5341 | G740-7375341 | RG-032144 WO-801816 | 7375341 | SEAL, housing upper (used w/GEAR 8329724) (superse- ded by SEAL 8332551) | 1 | ea |
| 14-2 | | | | | | SEAL, oil, arm shaft (1 1/16 divided shaft)..... | 1 | ea |

| | | | | | | | | |
|------|----|---------------|--------------|---|---------|--|---|----|
| 14-2 | | | G758-8332551 | TLS-B112A56-7 RG-032188 WO-808414 | 8332551 | SEAL, PLAIN ENCASED, housing upper (used w/GEAR 8332549) (supersedes SEAL 8332553) | 1 | ea |
| | | | G740-7375155 | WO-801279 | 7375155 | SEAL, steering column to floor (used on vehicles through serial no. 71065) | 1 | ea |
| | | | | WO-811407 | | SEAL, steering column to floor (used on vehicles after serial no. 71065) | 1 | ea |
| 14-2 | | 5330-741-2580 | G740-7412580 | WO-804392 | 7412580 | SEAL, steering jacket (used w/GEAR 8329724) | 1 | ea |
| 14-3 | | 2530-703-6567 | G503-7036567 | CA-S7733 WO-630755 | 7036567 | SEAT, ball, drag link | 2 | ea |
| 14-3 | | | G503-7036588 | CA-S5144 WO-630753 | 7036588 | SEAT, drag link ball spring | 2 | ea |
| | | | | RG-028166 | 8677035 | SEAT, steering column bearing spring | 1 | ea |
| | | | | WO-801423 | | | | |
| 14-2 | | 5305-270-7386 | G758-8329728 | RG-021162 | 8329728 | SET SCREW, adj, Pitman shaft (in side cover) | 1 | ea |
| | | | | WO-807472 | | | | |
| 14-2 | | | | RG-TL124002 -4.47/4.41 | 8677533 | SHAFT, Pitman arm, w/LEVER | 1 | ea |
| | | | | WO-807479 | | | | |
| 14-2 | H1 | 012-4949 | H001-4185801 | | 124949 | NUT, plain, hex, S, cd- or zn-pltd, 3/4-16NF-2 | 1 | ea |
| 14-2 | H1 | 013-1046 | H101-0131046 | | 131046 | WASHER, lock, S, cd- or zn-pltd, 3/4 in. | 1 | ea |
| | | | G758-8329729 | RG-9474-4 1/16 WO-807478 | 8329729 | SHAFT, Pitman arm, w/NUT and lock WASHER, assy. | 1 | ea |
| | | | | WO-649219 | 7375179 | SHAFT, pivot, bellcrank | 1 | ea |
| | | 2530-737-5179 | G740-7375179 | WO-649240 | 7375178 | NUT, locking, hex, 5/8-18NF | 1 | ea |
| | | 5310-737-5178 | G740-7375178 | | 131018 | WASHER, flat, 1 5/16 ID, 1 3/4 OD, 0.134 thk | 1 | ea |
| | H1 | 013-1018 | H101-0131018 | | 131016 | WASHER, flat, S, cd- or zn-pltd, 5/8 in. | 1 | ea |
| | H1 | 013-1016 | H001-7043861 | | 8329730 | SHAFT, STEERING (with welded integral cam and NUT 7412579), assy | 1 | ea |
| | | | G758-8329730 | RG-9472-42 3/8 WO-807480 | | | | |
| 14-3 | | | G503-7036584 | CA-SX1110 WO-A623 | 7036584 | SHIELD, dust cover | 2 | ea |
| | | | | WO-803203 | 8332516 | SHIM, mtg, housing, 0.0418 thk | † | ea |
| | | | | WO-809723 | 8332515 | 0.097 thk | | |
| | | | | WO-803202 | 8332517 | 0.1196 thk | | |
| | | 2530-737-1030 | G503-7371030 | WO-638918 | 7371030 | SHIM, mtg, housing to frame | † | ea |
| 14-2 | | 2530-769-6350 | G503-7696350 | RG-033046 WO-639108 | 7696350 | SHIM, S, housing upper cover, 0.002 thk | † | ea |
| | | | | RG-033047 | 7696351 | 0.003 thk | | |
| | | 2530-769-6351 | G503-7696351 | WO-639109 | | | | |
| | | | | RG-033048 | 7696352 | 0.010 thk | | |
| | | 2530-769-6352 | G503-7696352 | WO-639110 | | | | |
| | | | | WO-647089 | 7375839 | SPACER, steering gear to frame bolt | 1 | ea |
| 14-3 | | 2530-737-5339 | G740-7375339 | | 7036587 | SPRING, ball seat | 2 | ea |
| | | 5340-703-6587 | G503-7036587 | CA-S5145 WO-630754 | | | | |

1401

| (1) ILLUSTRATION NO. | (2) REFER- ENCE SYMBOLS | (3) FEDERAL STOCK NO. | (4) ORDNANCE STOCK NO. | (5) MFR'S PART NO. | (6) ORDNANCE PART NO. | (7) DESCRIPTION | (8) QUANTITY INCOR- PORATED IN UNIT | (9) UNIT OF ISSUE |
|---|----------------------------------|-----------------------------|------------------------------|--|-----------------------------|--|---|----------------------------|
| GROUP 14—CONTROLS—Continued | | | | | | | | |
| 1401—STEERING CONTROLS—Continued | | | | | | | | |
| 14-4 | | 5340-737-5177 | G740-7375177 G503-7373111 | WO-801666 SP-17347 | 7375177 7373111 | SPRING, bellcrank to bracket dust seal..... SPRING, front axle tie rod..... | 1 4 | ea ea |
| 14-2 | | 5340-769-6370 | G503-7696370 | WO-A6305 WO-639191 RG-078053-9¼ WO-809078 | 7696370 | SPRING, jacket upper bearing..... TUBE, oil seal, steering gear (horn adapter)..... | 1 1 | ea ea |
| 14-2 | | | G740-7375337 | RG-9470-9 WO-801186 | 7375337 | TUBE, oil seal, steering gear, assy (horn adapter)..... Composed of: 1 PLUG 1 TUBE | 1 | ea |
| 14-4 | | | | RG-402129 RG-078053-9¼ SP-30067-2 TP-14RT225 WO-806370 | | TUBE, tie rod, left (17.19 lg)..... | 1 | ea |
| 14-4 | | | | SP-30067-1 TP-14RT224 WO-806369 | 8677519 | TUBE, tie rod, right (19.06 lg)..... | 1 | ea |
| 14-2; 18-6 | | | G740-7375336 | SL-1238 WO-800737 | 7375336 | WHEEL, steering, assy..... | 1 | ea |
| 14-2 | | 5310-741-2579 | G740-7412579 | RG-026097 | 7412579 | NUT, SLEEVE: hex, sp, S, cd-pltd, 13/16-20NEF-2 (part of SHAFT, STEERING, w/integral CAM (welded)) | 1 | ea |

262

| KEY ITEM | PART NO | GROUP | KEY ITEM | PART NO | GROUP | KEY ITEM | PART NO | GROUP |
|-----------------|-----------|-------|----------------|-----------|-------|-----------------|-------------|-------|
| A—BAR | 8331831 | 2101 | H—BRACKET | 8677517 | 1501 | Q—REINFORCEMENT | 8677420 | 1501 |
| B—BRACKET | 8677505 | 1501 | J—CROSS MEMBER | WO-800605 | 1501 | R—CROSS MEMBER | 7372507 | 1501 |
| C—BRACKET, ASSY | 8677503 | 1501 | K—BRACKET | 8677428 | 1501 | S—SUPPORT | 8677429 | 1501 |
| D—SUPPORT | 8328475 | 1501 | L—OUTRIGGER | 8677291 | 1501 | T—CROSS MEMBER | 8673467 | 1501 |
| E—OUTRIGGER | WO-907147 | 1501 | M—BRACKET | 8677649 | 1501 | U—CROSS MEMBER | 8673477 | 1501 |
| F—BRACKET | 7697870 | 1501 | N—CROSS MEMBER | 8677579 | 1501 | V—BRACKET | MSP-344-306 | 1501 |
| G—BRACKET | 7372506 | 1501 | P—BRACKET | 8677416 | 1501 | W—REINFORCEMENT | 8677650 | 1501 |

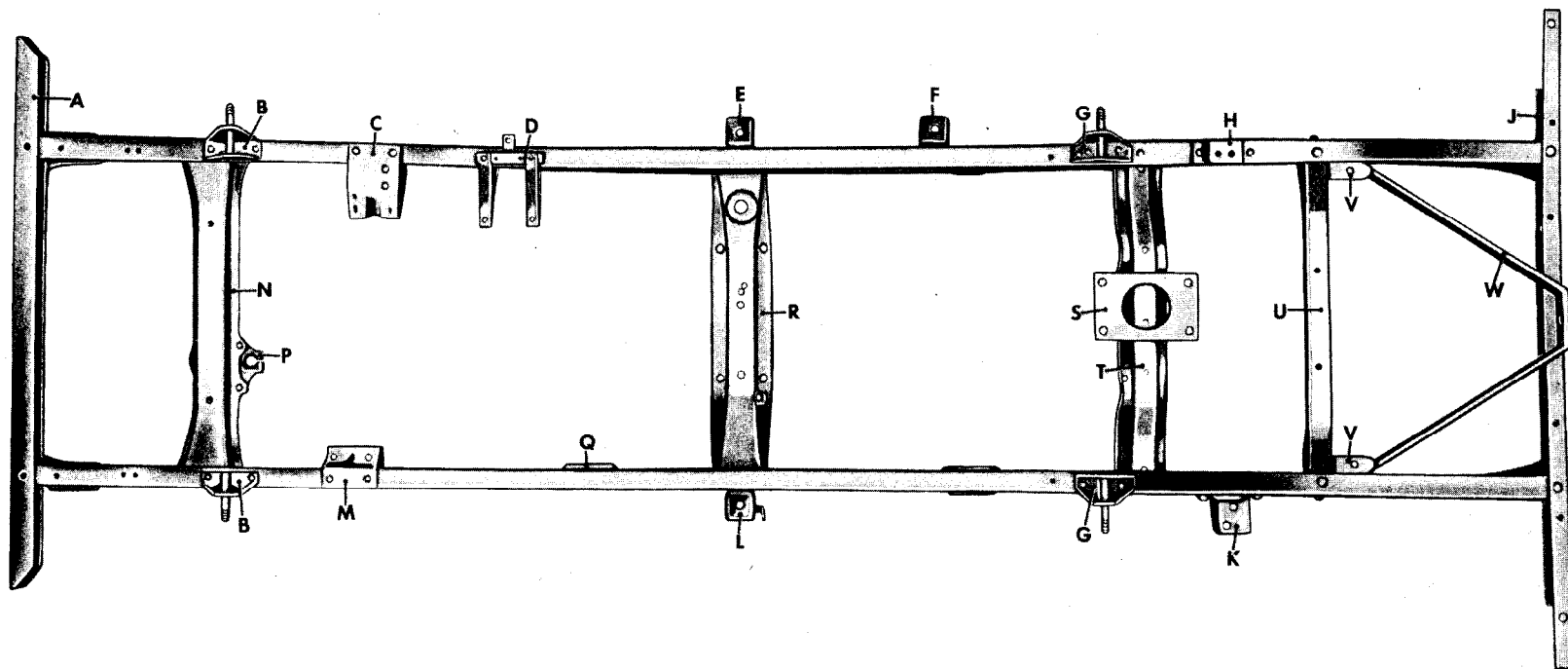

263

RA PD 367243

Figure 15-1. Frame assy

| KEY | ITEM | PART NO |
|-----|---------|---------|
| A | LATCH | 7524313 |
| B | SPRING | 7044253 |
| C | LOCK | 7524314 |
| D | RING | 583035 |
| E | BOLT | 124169 |
| F | WASHER | 120384 |
| G | NUT | 120371 |
| H | PINTLE | 7073213 |
| J | PIN | 7524315 |
| K | FITTING | 504203 |
| L | PIN | 7524316 |

ITEMS E, F, AND G ARE NOT PART OF ASSY 7073209.
ALL PARTS LISTED ARE IN GROUP 1503.

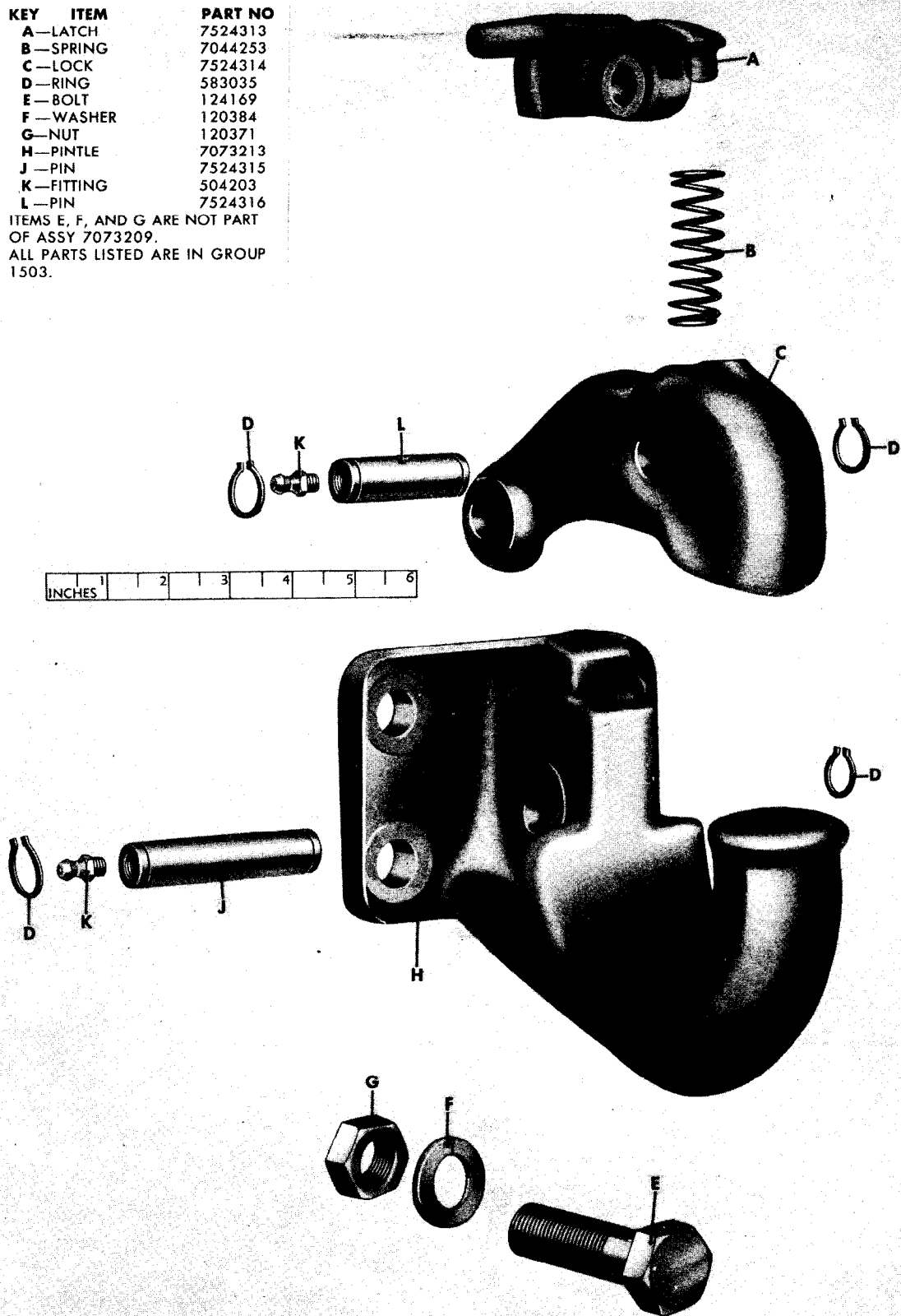

RA PD 181686

Figure 15-2. Pinle hook, assy (7073209)—exploded view

KEY ITEM

- A**—BRACKET, ASSY
- B**—STUD
- C**—WHEEL
- D**—NUT
- E**—SCREW W/LOCKWASHER
- F**—NUT

PART NO

- WO-689016
- WO-685174
- 7387807
- 5232405
- 425401
- 120377

GROUP

- 1504
- 1504
- 1311
- 1311
- 1504
- 1504

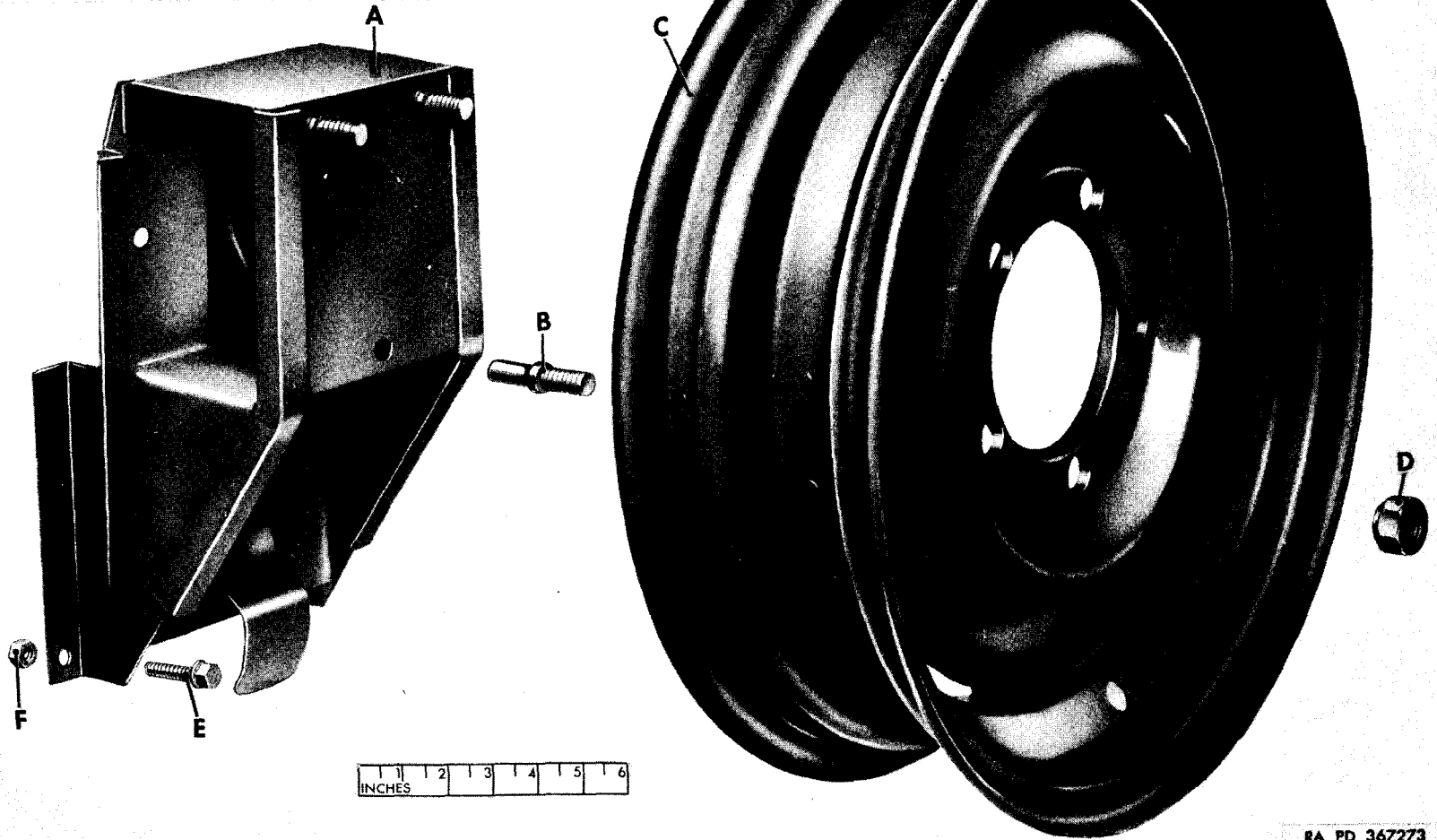

RA PD 367273

Figure 15-3. Spare wheel carrier—exploded view

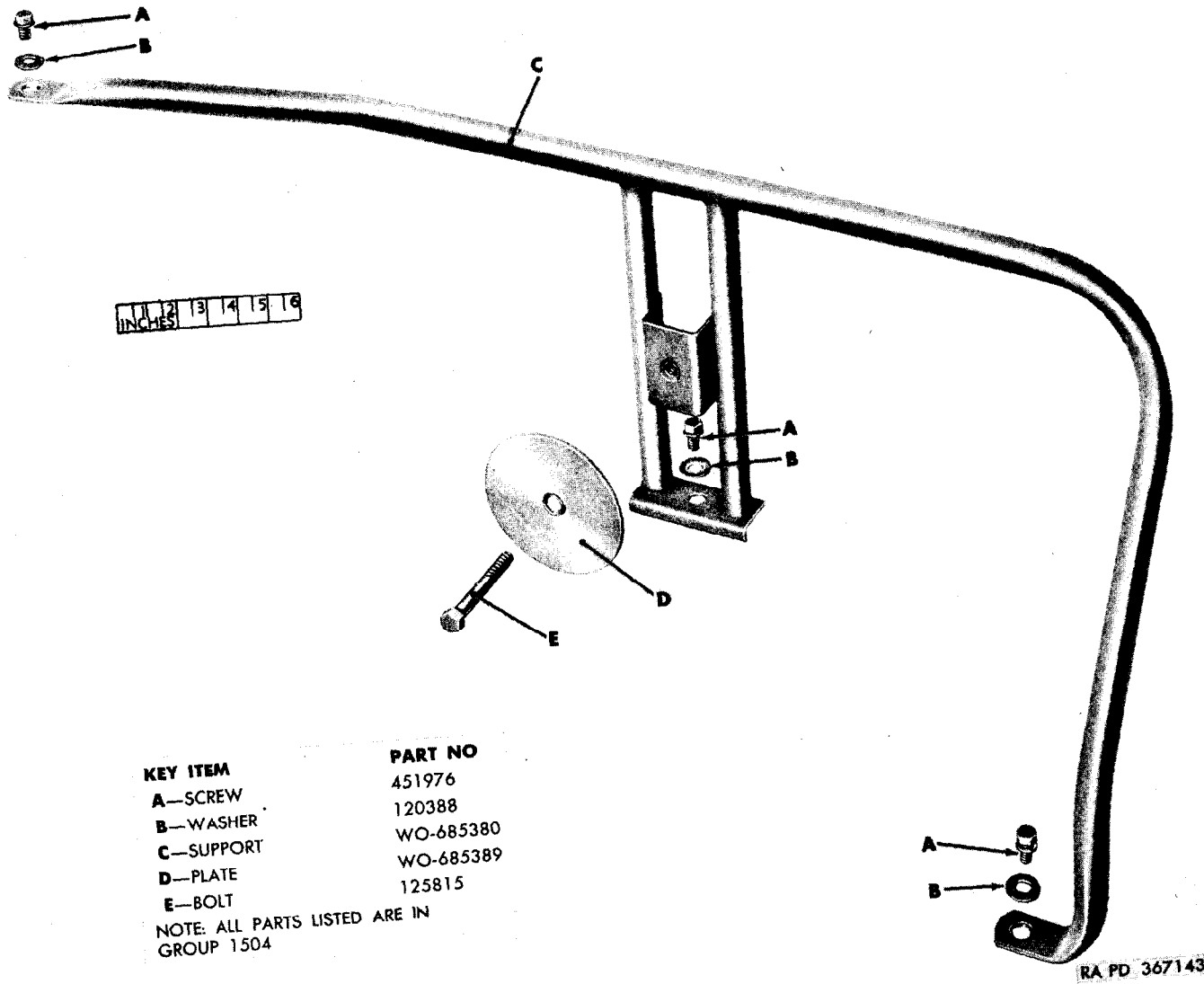

| KEY ITEM | PART NO |
|-----------|-----------|
| A—SCREW | 451976 |
| B—WASHER | 120388 |
| C—SUPPORT | WO-685380 |
| D—PLATE | WO-685389 |
| E—BOLT | 125815 |

NOTE: ALL PARTS LISTED ARE IN GROUP 1504

Figure 15-4. Spare wheel carrier (M170)—exploded view

| (1) ILLUSTRATION NO. | (2) REFER- ENCE SYMBOLS | (3) FEDERAL STOCK NO. | (4) ORDNANCE STOCK NO. | (5) MFR'S PART NO. | (6) ORDNANCE PART NO. | (7) DESCRIPTION | (8) QUANTITY INCOR- PORATED IN UNIT | (9) UNIT OF ISSUE |
|------------------------------------|----------------------------------|-----------------------------|------------------------------|--------------------------|-----------------------------|--|---|----------------------------|
| GROUP 15—FRAME AND BRACKETS | | | | | | | | |
| 1501—FRAME AND BRACKETS | | | | | | | | |
| | | 3120-368-4938 | G740-7697574 | WO-A546 | 7697574 | BEARING, bushing type (front spring bracket, front, and rear spring bracket, rear) | 4 | ea |
| 15-1 | | 2510-769-7870 | G503-7697870 | WO-645072 | 7697870 | BRACKET, body, right, No. 2 | 1 | ea |
| 15-1 | | | | MSP-344-306 WO-805512 | | BRACKET, body support, rear | 2 | ea |
| | | | | MSP-344-40 WO-A185 | 8393046 | BRACKET, brake pedal retracting spring | 1 | ea |
| 15-1 | | | | WO-805552 | 8677503 | BRACKET, engine front support, right, assy Composed of: | 1 | ea |
| | | | | | 8677648 | 1 BRACKET | | |
| | | | | | 8677293 | 1 REINFORCEMENT | | |
| 15-1 | | | | WO-807719 | 8673515 | BRACKET, front brake hose | 1 | ea |
| | | | | MSP-344-290 | 8677649 | BRACKET, front engine support, left | 1 | ea |
| | | | | WO-805519 | | | | |
| | | | | MSP-344-289 | 8677648 | BRACKET, front engine support, right | 1 | ea |
| | | | | WO-805520 | | | | |
| 15-1; 16-1 | | | | WO-805635 | 8677505 | BRACKET, front shock absorber, assy | 2 | ea |
| | | | | WO-805514 | 8677500 | BRACKET, front spring shackle, front | 2 | ea |
| | | | | WO-807787 | 8673518 | BRACKET, fuel line clip | 1 | ea |
| 15-1 | | | | WO-807587 | 8677534 | BRACKET, ground cable (voltage regulator) | 1 | ea |
| 15-1 | | | | WO-806217 | 8677428 | BRACKET, mtg, machine gun, left | 1 | ea |
| 15-1; 16-2 | | 2540-737-2506 | G740-7372506 | WO-806218 | 8677517 | BRACKET, mtg, machine gun, right | 1 | ea |
| 16-1, 2 | | | | WO-800825 | 7372506 | BRACKET, rear, shock absorber | 2 | ea |
| 16-2 | | 2510-737-1056 | G503-7371056 | WO-806910 | 8677526 | BRACKET, rear spring pivot, front | 2 | ea |
| | | | | SMA-FLA2941 | 7371056 | BRACKET, rear spring shackle, front (welded) | 2 | ea |
| | | | | MSP-344-47 WO-A544 | | | | |
| | | | | | 7697574 | Composed of: | | |
| | | | | | | 2 BRACKET | | |
| 15-1 | | | | WO-A545 | | 2 BRACKET | | |
| | | | | WO-804453 | 8677416 | BRACKET, steering bellcrank support | 1 | ea |
| | H1 | 5305-012-0678 | H001-5421441 | | 120678 | BOLT, cap, hex-hd, S, cd- or zn-pltd, $\frac{3}{8}$ -24NF-3 x 2 (bellcrank support bracket to front cross member) | 1 | ea |
| | H1 | | H001-4040541 | | 503351 | NUT, self-lkg, $\frac{3}{8}$ -24NF | 1 | ea |
| | | | | WO-809118 | | BRACKET, support, radiator guard | 1 | ea |
| | | | G758-8328446 | WO-800048 | 8328446 | BRACKET, tie-down | 4 | ea |
| | H1 | 012-3567 | H001-5422921 | | 123567 | BOLT, mach, hex-hd, S, cd- or zn-pltd, $\frac{1}{16}$ -20NF-3 x 1 | 8 | ea |
| | H1 | 5310-012-0383 | H001-7025771 | | 120383 | WASHER, lock, med, S, cd- or zn-pltd, $\frac{1}{16}$ in. | 8 | ea |

1501

269

| (1) | (2) | (3) | (4) | (5) | (6) | (7) | (8) | (9) |
|--|-------------------|-------------------|--------------------|----------------|-------------------|---|-------------------------------|---------------|
| ILLUSTRATION NO. | REFERENCE SYMBOLS | FEDERAL STOCK NO. | ORDNANCE STOCK NO. | MFR'S PART NO. | ORDNANCE PART NO. | DESCRIPTION | QUANTITY INCORPORATED IN UNIT | UNIT OF ISSUE |
| GROUP 15—FRAME AND BRACKETS—Continued | | | | | | | | |
| 1501—FRAME AND BRACKETS—Continued | | | | | | | | |
| 15-1 | | | | WO-A1150 | 8673467 | CROSS MEMBER, frame, center..... | 1 | ea |
| 15-1 | | | | WO-805643 | 8677579 | CROSS MEMBER, frame, front..... | 1 | ea |
| 15-1 | | | | WO-800605 | | CROSS MEMBER, frame, rear..... | 1 | ea |
| 15-1 | | | | WO-646942 | 8673477 | CROSS MEMBER, frame, rear intermediate..... | 1 | ea |
| 15-1 | | 2510-737-2507 | G740-7372507 | WO-649705 | 7372507 | CROSS MEMBER, rear engine support..... | 1 | ea |
| | H1 | | H001-5455281 | | 181638 | SCREW, hex-hd, 3/8-24UNF-2A x 1 1/8..... | 4 | ea |
| | H1 | 050-3351 | H001-4040541 | | 503351 | NUT, self-lkg, hex, 3/8-24NF (critical installations)..... | 4 | ea |
| | | | | WO-K700695 | | WASHER, flat, 1 1/2 ID, 1 OD..... | 4 | ea |
| | | 2520-495-9515 | G503-7371037 | WO-A6740 | 7371037 | CUP, retn, transfer case support insulator..... | 1 | ea |
| | | | | WO-906263 | | EXTENSION, cross member, rear (welded) (M170)..... | 1 | ea |
| | | | | WO-906408 | | EXTENSION, outrigger, body no. 1 right..... | 1 | ea |
| | | | | WO-808945 | | FRAME, assy (M170)..... | 1 | ea |
| | | | | WO-805715 | 8677578 | FRAME, assy (welded) (used on vehicles through serial no. 79490) (M38A1)..... | 1 | ea |
| 15-1 | | | | WO-809121 | | FRAME, assy (welded) (used on vehicles after serial no. 79490) (M38A1)..... | 1 | ea |
| | H1 | 5320-011-3354 | H101-0113354 | WO-906739 | 113354 | LINER, body sill (thin)..... | 1 | ea |
| | | | | MID-F2011 | 8677283 | RIVET, oval-hd, split, S, 3/4 x 1/16 (liner to no. 1 body outrigger)..... | 2 | ea |
| | | | | WO-642052 | | NUT, grommet, 1/16-20NF-2 (hold-down loop)..... | 8 | ea |
| | | | | MSP-200-145 | 8677040 | NUT, grommet, 1/2-20NF-2 (lifting rings)..... | 8 | ea |
| | | | | WO-801661 | | | | |
| | H1 | | H101-0585806 | | 585806 | NUT, welding, 1/4-20NC-2 (rear engine plate)..... | 4 | ea |
| | H1 | | H101-0585811 | | 585811 | NUT, welding, S, 3/8-24NF-2 (fender support bracket)..... | 8 | ea |
| 15-1 | | | | WO-645702 | 8677291 | OUTRIGGER, body, left, no. 1, assy (includes BRACKET, clutch release SPRING)..... | 1 | ea |
| | | | | WO-645071 | 8677289 | OUTRIGGER, body, left and right, no. 1..... | 2 | ea |
| 15-1 | | | | WO-907147 | | OUTRIGGER, body, right, no. 1, assy..... | 1 | ea |
| | | | | WO-805515 | 8677419 | PLATE, reinforcement, rear..... | 1 | ea |
| | | | | WO-808788 | | PLATE, reinforcement, rear engine support cross member..... | 2 | ea |
| | | | | WO-800781 | | PLATE, skid, under frame..... | 1 | ea |
| | H1 | 012-0915 | H001-3015411 | | 120915 | BOLT, rd-hd, sq-nk, S, cd- or zn-pltd, 3/8-16NC-2 x 1..... | 4 | ea |
| | H1 | | H101-0271190 | | 271190 | NUT, hex, w/ext-teeth lock washer, Keps style, 3/8-16NC-2..... | 4 | ea |
| | H1 | 5310-012-0394 | H001-7043741 | | 120394 | WASHER, FLAT, light series, S, cd- or zn-pltd, 3/8 in..... | 4 | ea |
| | | | | WO-647026 | 8677293 | REINFORCEMENT, engine front support brackets, RH..... | 1 | ea |

| | | | | | | | | |
|---|-----|---------------|--------------|------------------------|---------|---|---|----|
| 15-1 | | | | WO-801695 | 8673507 | REINFORCEMENT, frame cross member, rear..... | 1 | ea |
| | | | | WO-805518 | 8677650 | REINFORCEMENT, frame rear..... | 1 | ea |
| | | | | WO-808789 | | REINFORCEMENT, frame, rear spring shackle bracket, left | 1 | ea |
| | | | | WO-808790 | | REINFORCEMENT, frame, rear spring shackle bracket, right | 1 | ea |
| | | | | WO-805555 | 8677504 | REINFORCEMENT, frame side member, front left, assy. | 1 | ea |
| 15-1 | | | | WO-860216 | 8673384 | REINFORCEMENT, machine gun support..... | 4 | ea |
| | | | | WO-805575 | 8677420 | REINFORCEMENT, side member, left (welded)..... | 1 | ea |
| | | | | WO-805556 | | REINFORCEMENT, side member, front, right..... | 1 | ea |
| | | | | WO-805576 | 8677421 | REINFORCEMENT, side member, right (welded)..... | 1 | ea |
| | H1 | 010-4097 | H001-0924218 | | 104097 | RIVET, solid, $\frac{5}{16}$ x $\frac{3}{4}$ (engine stay cable rear bracket (1), brake pedal retracting spring bracket (1)) | 2 | ea |
| | | | | WO-906663 | | SHIM, S, No. 9 (0.1495) ga (left end of cross member) (M170) | 1 | ea |
| | | | | WO-647415 | 8673968 | SPACER, bolt, snow plow..... | 2 | ea |
| 15-1 | | | | WO-809118 | | SUPPORT, guard panel..... | 1 | ea |
| 15-1 | | | | WO-806219 | 8677429 | SUPPORT, machine gun..... | 1 | ea |
| | | | G758-8328475 | WO-805719 | 8328475 | SUPPORT, mtg, voltage regulator..... | 1 | ea |
| 1503-PINTLE AND TOWING ATTACHMENTS | | | | | | | | |
| | H1 | 2540-741-0837 | G740-7410837 | WO-802765 | 7410837 | BRACKET, lifting hook, front, w/SPACER, assy..... | 2 | ea |
| | H1 | 012-4169 | H001-5424701 | | 124169 | BOLT, mach, $\frac{1}{2}$ -20NF-3 x 2..... | 2 | ea |
| | H1 | 012-0424 | H001-5424561 | | 120424 | SCREW, mach, cap, hex-hd, S, cd- or zn-pltd, $\frac{1}{2}$ - 20NF-3 x $1\frac{1}{4}$ | 2 | ea |
| | H1 | 5310-012-0384 | H001-7025801 | | 120384 | WASHER, lock, med, S, cd- or zn-pltd, $\frac{1}{2}$ in..... | 4 | ea |
| | H1 | 2510-769-7489 | G740-7697489 | WO-800051 | 7697489 | BRACKET, lifting hook, rear..... | 2 | ea |
| | H1 | | H101-0271476 | | 271476 | NUT, hex, w/ext-teeth-lock washer, S, cd- or zn-pltd, $\frac{1}{2}$ -20NF | 4 | ea |
| | H1 | 012-0424 | H001-5424561 | | 120424 | SCREW, mach, cap, hex-hd, S, cd- or zn-pltd, $\frac{1}{2}$ - 20NF-3 x $1\frac{1}{4}$ | 4 | ea |
| | H1 | 5310-012-0396 | H001-7043801 | | 120396 | WASHER, fl, S, cd- or zn-pltd, $\frac{17}{32}$ ID, $1\frac{1}{16}$ OD, 0.095 thk | 4 | ea |
| | | | | WO-800338 | 8676979 | CHAIN, snap clip (lifting hook)..... | 4 | ea |
| | | | G758-8328448 | WO-807564 | 8328448 | CLIP, snap, lifting hook (superseded by CLIP 8332074)..... | 4 | ea |
| | | | G758-8332074 | WO-809162 | 8332074 | CLIP, snap, lifting hook (supersedes CLIP 8328448)..... | 4 | ea |
| | | | | WO-807578 | | CLIP, snap, lifting hook, w/CHAIN, assy..... | 4 | ea |
| | | | | | 8676979 | Composed of: | | |
| | | | | | 8332074 | 1 CHAIN | | |
| | | | | | 145371 | 1 CLIP | | |
| | H1 | 014-5371 | H001-5614921 | | 145371 | SCREW, drive, rd-hd, S, cd- or zn-pltd, blunt-pt, No. 2 x $\frac{1}{4}$ | 4 | ea |
| 15-2 | H16 | 050-4203 | H016-0504203 | | 504203 | FITTING, lubr, hyd type, S, cd- or zn-pltd, $\frac{1}{4}$ -28NF male (ball check valve) (Alemite) | 2 | ea |
| 15-2 | | 2540-752-4313 | G503-7524313 | HLH-T63-O WO-801786 | 7524313 | LATCH, towing pintle..... | 1 | ea |

| (1) ILLUSTRATION NO. | (2) REFER- ENCE SYMBOLS | (3) FEDERAL STOCK NO. | (4) ORDNANCE STOCK NO. | (5) MFR'S PART NO. | (6) ORDNANCE PART NO. | (7) DESCRIPTION | (8) QUANTITY INCOR- PORATED IN UNIT | (9) UNIT OF ISSUE |
|-------------------------|----------------------------------|-----------------------------|------------------------------|-------------------------|-----------------------------|--|---|----------------------------|
| | | | | | | GROUP 15—FRAME AND BRACKETS—Continued | | |
| | | | | | | 1503—PINTLE AND TOWING ATTACHMENTS | | |
| | | | | | | — Continued | | |
| | | | | HLH-T62-OL WO-801781 | | LOCK, left half..... | 1 | ea |
| | | | | HLH-T62-OR WO-801782 | | LOCK, right half..... | 1 | ea |
| 15-2 | | | | HLH-T62-O WO-801780 | 7524314 | LOCK, towing pintle..... | 1 | ea |
| | | 2540-752-4812 | G503-7524812 | HLH-T62-01 WO-801779 | 7524312 | LOCK, towing pintle, w/LATCH, assy..... | 1 | ea |
| 15-2 | | 5815-752-4816 | G740-7524816 | HLH-T67-O WO-801784 | 7524316 | PIN, towing pintle latch..... | 1 | ea |
| 15-2 | | 2540-752-4815 | G503-7524815 | HLH-T64-O WO-801787 | 7524315 | PIN, towing pintle lock..... | 1 | ea |
| 15-2 | | 2540-707-3213 | G503-7073213 | HLH-T60-O WO-801778 | 7073213 | PINTLE, towing..... | 1 | ea |
| 15-2; 18-4 | | 2540-707-3209 | G503-7073209 | HLH-T60-AO WO-800929 | 7073209 | PINTLE, towing, assy..... | 1 | ea |
| 15-2 | H1 | 012-4169 | H001-5424701 | | 124169 | BOLT, mach, 1/2-20NF-3 x 2..... | 4 | ea |
| 15-2 | H1 | 012-0371 | H001-4167681 | | 120371 | NUT, plain, hex, s-fin, light, S, cd- or zn-pltd, 1/2-20NF-2..... | 4 | ea |
| 15-2 | H1 | 5310-012-0384 | H001-7025801 | | 120384 | WASHER, lock, med, S, cd- or zn-pltd, 1/2 in..... | 4 | ea |
| | | | | WO-801682 | 8677065 | REINFORCEMENT, frame, towing pintle..... | 1 | ea |
| | | | | WO-805513 | | REINFORCEMENT, towing pintle lower..... | 1 | ea |
| 15-2 | H2 | | H002-0583035 | | 583035 | RING, retn, snap, exter, S, cd- or zn-pltd, 0.500 shaft dia (towing pintle lock pin)..... | 4 | ea |
| | | 2540-741-0838 | G740-7410838 | WO-802768 | 7410838 | SHACKLE, lifting, front..... | 2 | ea |
| | | 2510-769-7512 | G740-7697512 | WO-800820 | 7697512 | SHACKLE, lifting, rear..... | 2 | ea |
| | | 5315-769-7490 | G740-7697490 | WO-800337 | 7697490 | PIN, stght, headed, clevis, S, cd- or zn-pltd, 3/4 x 2 11/16..... | 4 | ea |
| | | | G740-8328264 | WO-800817 | 8328264 | SPACER, lifting shackle bracket, rear..... | 2 | ea |
| 15-2 | | 5340-794-4253 | G503-7044253 | HLH-78 WO-801785 | 7044253 | SPRING, TOWING PINTLE, compression, S, 0.625 dia stock, 5/8 dia coil, 9 coils 1 3/4 free lg (pintle hook latch)..... | 1 | ea |
| | | | | WO-811673 | | WASHER, spring tension 0.843 ID, 1.312 OD (between lift hook and bracket, RH rear) (M170)..... | 1 | ea |

1504—SPARE WHEEL CARRIER

| | | | | | | | | |
|------------|----|---------------|--------------|-------------|---------|--|---|----|
| | | | | WO-685363 | | BRACKET, spare wheel (M170) | 1 | ea |
| | | | | WO-685362 | | BRACKET, spare wheel, assy (M170) | 1 | ea |
| | | | | WO-685363 | | Composed of: 1 BRACKET | | |
| | | | | | 8677040 | 1 NUT | | |
| | | | | WO-681190 | 8677658 | BRACKET, spare wheel carrier, assy (welded) (superseded by BRACKET WO-689016) (used on vehicles through serial no. 73455) | 1 | ea |
| | | | | WO-683828 | | Composed of: | | |
| | | | | WO-683852 | | 1 BRACKET | | |
| | | | | WO-689016 | | 1 SUPPORT | | |
| 15-3; 18-4 | | | | | | BRACKET, spare wheel carrier, includes SUPPORT, and REINFORCEMENTS, assy (welded) (used on vehicles after serial no. 73455) (supersedes BRACKET 8677658) (M38A1) | 1 | ea |
| | | 2510-769-7436 | G740-7697436 | WO-673344 | 7697436 | BRACKET, support, spare wheel, w/STUD, assy (used on vehicles through serial no. 40951) (superseded by BRACKET WO-689016) | 1 | ea |
| | | | | MSP-200-145 | 8677040 | NUT, clinch 1/2-20NF-2 (M170) | 1 | ea |
| | | | | WO-801661 | | | | |
| 15-4 | | | | WO-685389 | | PLATE, spare tire retainer (M170) | 1 | ea |
| 271 | | | | | 428610 | BOLT, hex-hd, S, cd- or zn-pltd, 1/2-20NF x 3 1/2 (superseded by BOLT 125815) | 1 | ea |
| 15-4 | H1 | | H101-0125815 | | 125815 | BOLT, hex-hd, S, cd- or zn-pltd, 1/2-20NF x 4 3/4 (supersedes BOLT 428610) | 1 | ea |
| | | | | WO-673349 | 8677259 | PLATE, spare wheel support and reflector retainer | 1 | ea |
| | H1 | 015-5937 | H101-0155937 | | 155937 | BOLT, mach, fl-hd, S, cd- or zn-pltd, no. 10-24NC-2 x 1/2 | 2 | ea |
| | H1 | | H101-0271166 | | 271166 | NUT, hex, w/ext-teeth lock washer, Keps type, no. 10-24NC-2 | 2 | ea |
| | | | G758-8330950 | WO-682074 | 8330950 | SPACER, rear body panel to spare wheel support | 2 | ea |
| | | | | WO-664418 | | STUD, S, 1/2-20NC-2, RH thd (superseded by STUD WO-685174) (used on vehicles through serial no. 65901) | 3 | ea |
| 15-3 | | | | WO-685174 | | STUD, S, 1/2-20NC-2A, RD thd (support bracket, spare wheel) (supersedes STUD WO-664418) (used on vehicles after serial no. 65901) | 3 | ea |
| | | 2510-769-7441 | G740-7697441 | WO-673420 | 7697441 | SUPPORT, spare wheel (used on vehicles through serial no. 40951) (superseded by BRACKET WO-689016) | 1 | ea |
| | H1 | 012-6715 | H001-3015511 | | 126715 | BOLT, sq-nk, carriage, rd-hd, S, cd- or zn-pltd, 3/8-16NC-2 x 3 1/2 | 2 | ea |

1504

| (1) ILLUSTRATION NO. | (2) REFERENCE SYMBOLS | (3) FEDERAL STOCK NO. | (4) ORDNANCE STOCK NO. | (5) MFR'S PART NO. | (6) ORDNANCE PART NO. | (7) DESCRIPTION | (8) QUANTITY INCORPORATED IN UNIT | (9) UNIT OF ISSUE |
|-------------------------|--------------------------|--|--|-----------------------|--------------------------|---|--------------------------------------|----------------------|
| | | | | | | GROUP 15—FRAME AND BRACKETS—Continued | | |
| | | | | | | 1504—SPARE WHEEL CARRIER—Continued | | |
| 15-3 | H1 | 2510-769-7441 012-0377 5305-769-7439 | G740-7697441 H001-4167581 G740-7697439 | WO-673420 | 7697441 120377 | SUPPORT—Continued | | |
| | | | | WO-673458 | 7697439 | NUT, plain, hex, $\frac{3}{8}$ -16NC-2 | 2 | ea |
| 15-3 | H1 | | H101-0425401 | | 425401 | SCREW, lock washer, hex-hd, S, cd- or zn-pltd, $\frac{3}{8}$ -16NC x $1\frac{1}{8}$ (superseded by SCREW 425401) | 2 | ea |
| 15-4; 18-2 | H1 | 5310-012-0382 | H001-7025741 | | 120382 | SCREW, int-teeth-lock washer, hex-hd, S, cd- or zn-pltd, $\frac{3}{8}$ -16NC-2 x $1\frac{1}{8}$ (supersedes SCREW 7697439) | 2 | ea |
| | | | | WO-685380 | | WASHER, lock, med (reg), S, cd- or zn-pltd, $\frac{3}{8}$ in. | 2 | ea |
| | H1 | | H101-9409113 | | 9409113 | SUPPORT, spare wheel weld nut) (M170) | 1 | ea |
| 15-4 | H1 | | H101-0451976 | | 451976 | BOLT, MACHINE, hex-hd, S, $\frac{3}{8}$ -24NF x $\frac{3}{4}$ w/lock washer, assy (superseded by SCREW 451976) | 3 | ea |
| | | | | | 453047 | SCREW, lock washer, sltd, hex-hd, S, cd- or zn-pltd, $\frac{3}{8}$ -16NC x $\frac{3}{4}$ (supersedes BOLT 9409113) (superseded by SCREW 453047) | 2 | ea |
| | | | | | | SCREW, mach, w/ext-lock washer, pan-hd, S, cd- or zn-pltd, $\frac{3}{8}$ -16NC x $\frac{3}{4}$ (supersedes SCREW 451976) | 1 | ea |
| 15-4 | H1 | 5310-012-0388 | H001-7045591 | | 120388 | (support to w/HOUSE) | | |
| | | | | | | WASHER, FLAT, plain, S, cd- or zn-pltd, $\frac{1}{16}$ ID, 1 OD, $\frac{5}{64}$ thk | 3 | ea |

272

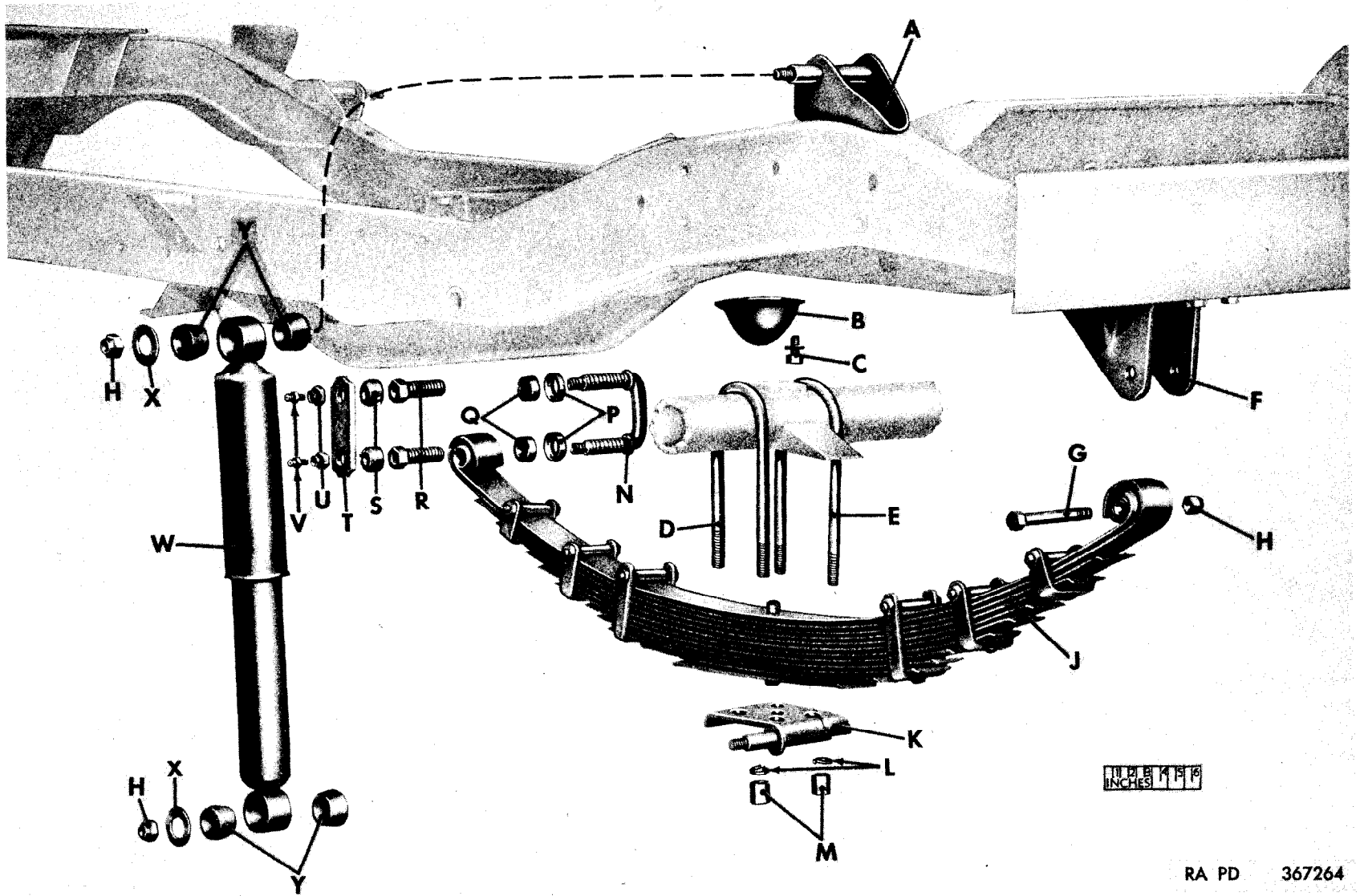

Figure 16-1. Front spring and shock absorber

| <i>Key</i> | <i>Item</i> | <i>Part No.</i> | <i>Group</i> |
|------------|------------------------|-----------------|--------------|
| A | -BRACKET, ASSY..... | 8677505 | 1501 |
| B | -BUMPER..... | WO-802454 | 1601.1 |
| C | -BOLT, w/LOCK WASHER.. | 9409102 | 1601.1 |
| D | -BOLT "U"..... | 8330509 | 1601.1 |
| E | -BOLT "U"..... | 8330510 | 1601.1 |
| F | -BRACKET..... | 8677526 | 1501 |
| G | -BOLT..... | 8332529 | 1601.1 |
| H | -NUT..... | 442830 | { 1601.1 |
| | | | 1604.1 |
| J | -SPRING, ASSY..... | 8333767 | 1601.1 |
| K | -SEAT..... | 7697601 | 1601.1 |
| L | -WASHER..... | 131100 | 1601.1 |
| M | -NUT..... | 7371061 | 1601.1 |
| N | -BOLT "U"..... | 8333138 | 1601.1 |
| P | -RETAINER..... | 7735843 | 1601.1 |
| Q | -SEAL..... | 7697602 | 1601.1 |
| R | -BEARING..... | 8332928 | { 1601.1 |
| | | | 1601.3 |
| S | -SEAL..... | 8333287 | 1601.1 |
| T | -PLATE..... | 8333259 | 1601.1 |
| U | -NUT..... | 443342 | 1601.1 |
| V | -FITTING..... | 504203 | 1601.1 |
| W | -ABSORBER..... | 8330512 | 1604.1 |
| X | -WASHER..... | 120389 | 1604.1 |
| Y | -BUSHING..... | 7343032 | 1604.1 |

Figure 16-1. Front spring and shock absorber—legend

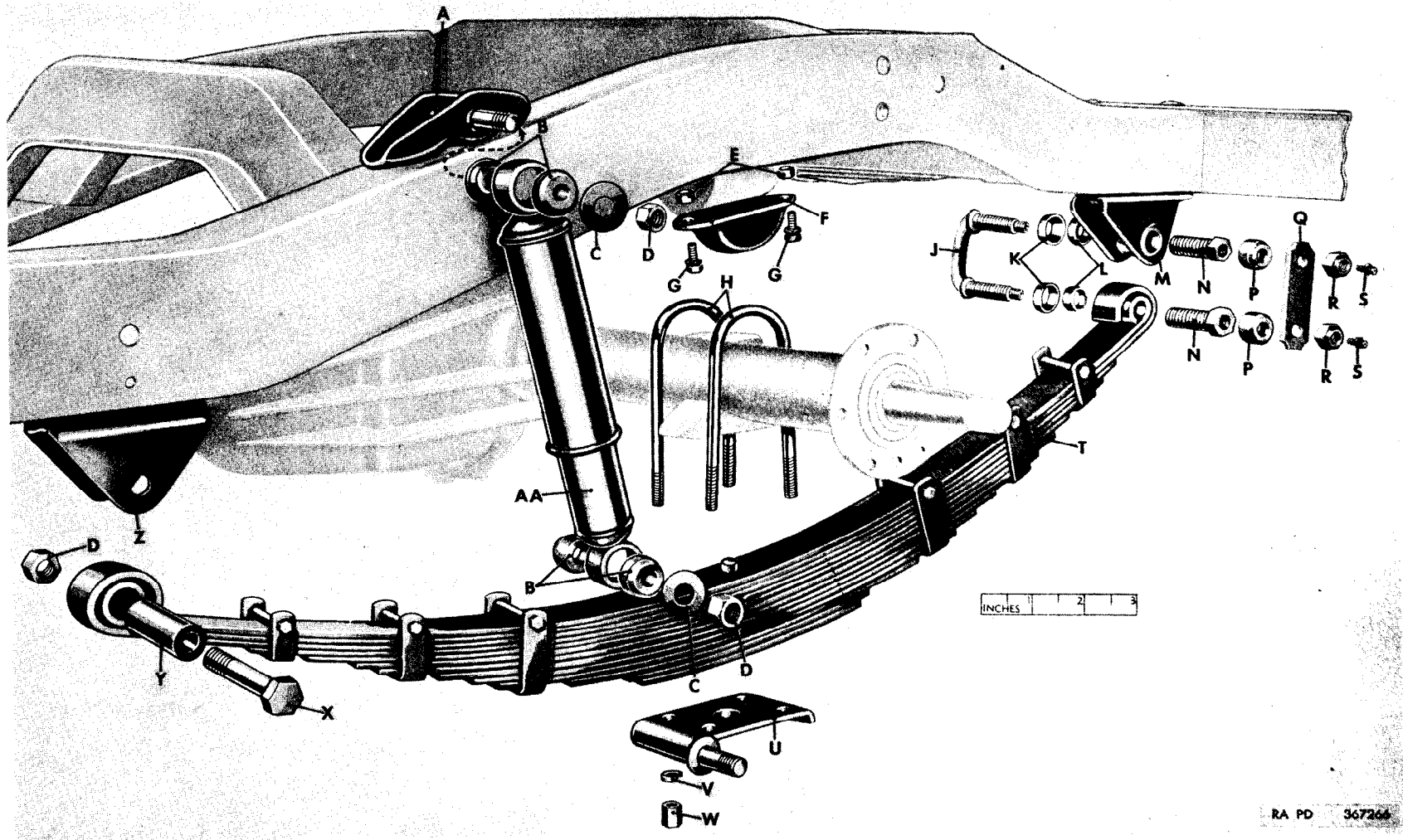
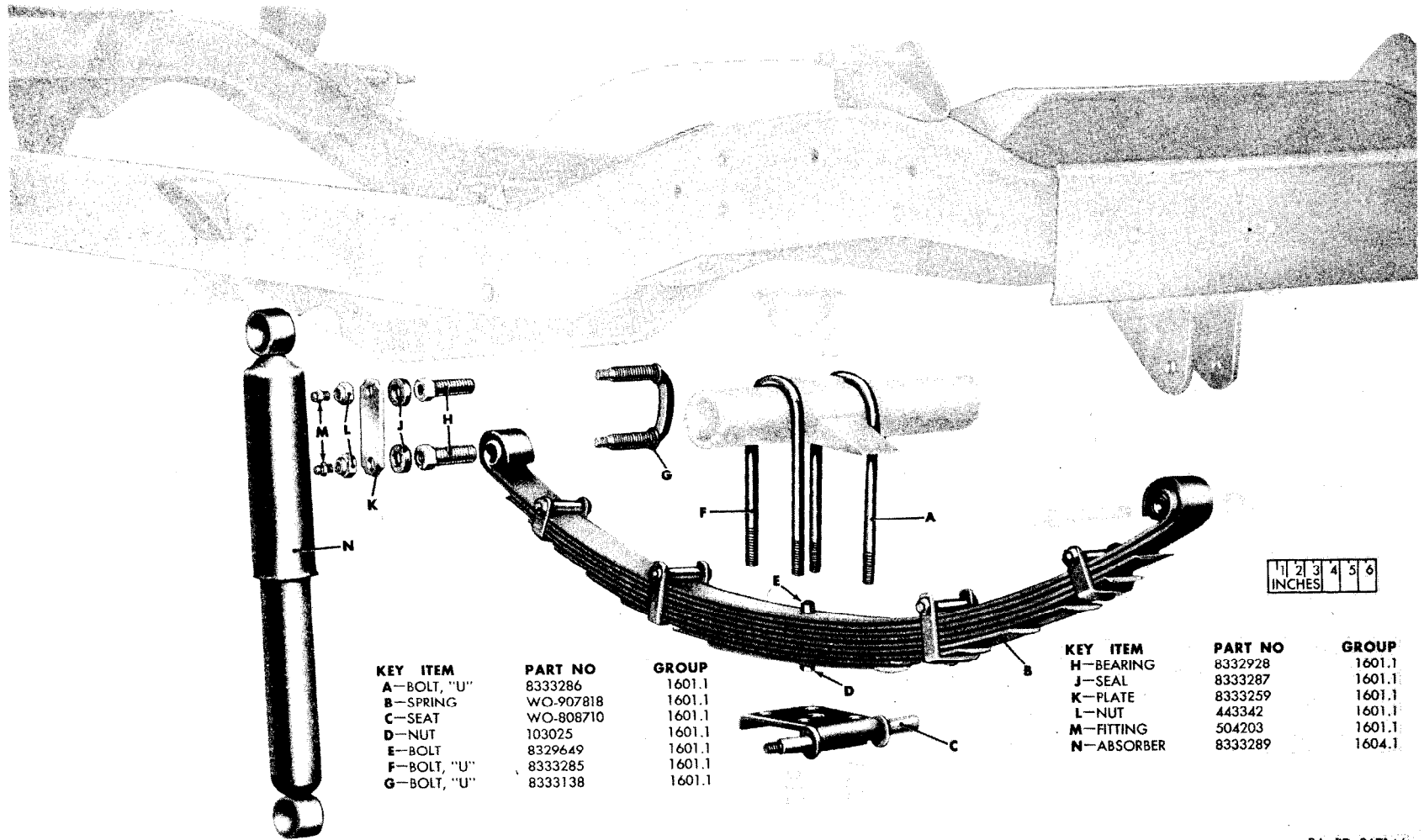

Figure 16-2. Rear spring and shock absorber

| <i>Key</i> | <i>Item</i> | <i>Part No.</i> | <i>Group</i> |
|------------|------------------------|-----------------|--------------------|
| A | —BRACKET..... | 7372506 | 1501 |
| B | —BUSHING..... | 7343032 | 1604.1 |
| C | —WASHER..... | 120389 | 1604.1 |
| D | —NUT..... | 442830 | } 1601.3 1604.1 |
| E | —NUT..... | 120368 | |
| F | —BUMPER..... | WO-802454 | 1601.3 |
| G | —BOLT, w/LOCK WASHER.. | 9409102 | 1601.3 |
| H | —BOLT "U"..... | 8330511 | 1601.3 |
| J | —BOLT "U"..... | 8333138 | 1601.3 |
| K | —RETAINER..... | 7735843 | 1601.3 |
| L | —SEAL..... | 7697602 | 1601.3 |
| M | —BRACKET..... | 7371056 | 1501 |
| N | —BEARING..... | 8332928 | 1601.3 |
| P | —SEAL..... | 8333287 | 1601.3 |
| Q | —PLATE..... | 8333259 | 1601.3 |
| R | —NUT..... | 443342 | 1601.3 |
| S | —FITTING..... | 504203 | 1601.3 |
| T | —SPRING, ASSY..... | 8333800 | 1601.3 |
| U | —SEAT..... | 7375000 | 1601.3 |
| V | —WASHER..... | 131100 | 1601.3 |
| W | —NUT..... | 7371061 | 1601.3 |
| X | —SCREW..... | 124155 | 1601.3 |
| Y | —BEARING..... | 8329602 | 1601.3 |
| Z | —BRACKET..... | 8677526 | 1501 |
| AA | —ABSORBER..... | 8330513 | 1604.1 |

Figure 16-2. Rear spring and shock absorber—legend



| KEY ITEM | PART NO | GROUP |
|-------------|-----------|--------|
| A—BOLT, "U" | 8333286 | 1601.1 |
| B—SPRING | WO-907818 | 1601.1 |
| C—SEAT | WO-808710 | 1601.1 |
| D—NUT | 103025 | 1601.1 |
| E—BOLT | 8329649 | 1601.1 |
| F—BOLT, "U" | 8333285 | 1601.1 |
| G—BOLT, "U" | 8333138 | 1601.1 |

| KEY ITEM | PART NO | GROUP |
|------------|---------|--------|
| H—BEARING | 8332928 | 1601.1 |
| J—SEAL | 8333287 | 1601.1 |
| K—PLATE | 8333259 | 1601.1 |
| L—NUT | 443342 | 1601.1 |
| M—FITTING | 504203 | 1601.1 |
| N—ABSORBER | 8333289 | 1604.1 |

RA PD 367144

Figure 16-3. Front spring and shock absorber (M170)

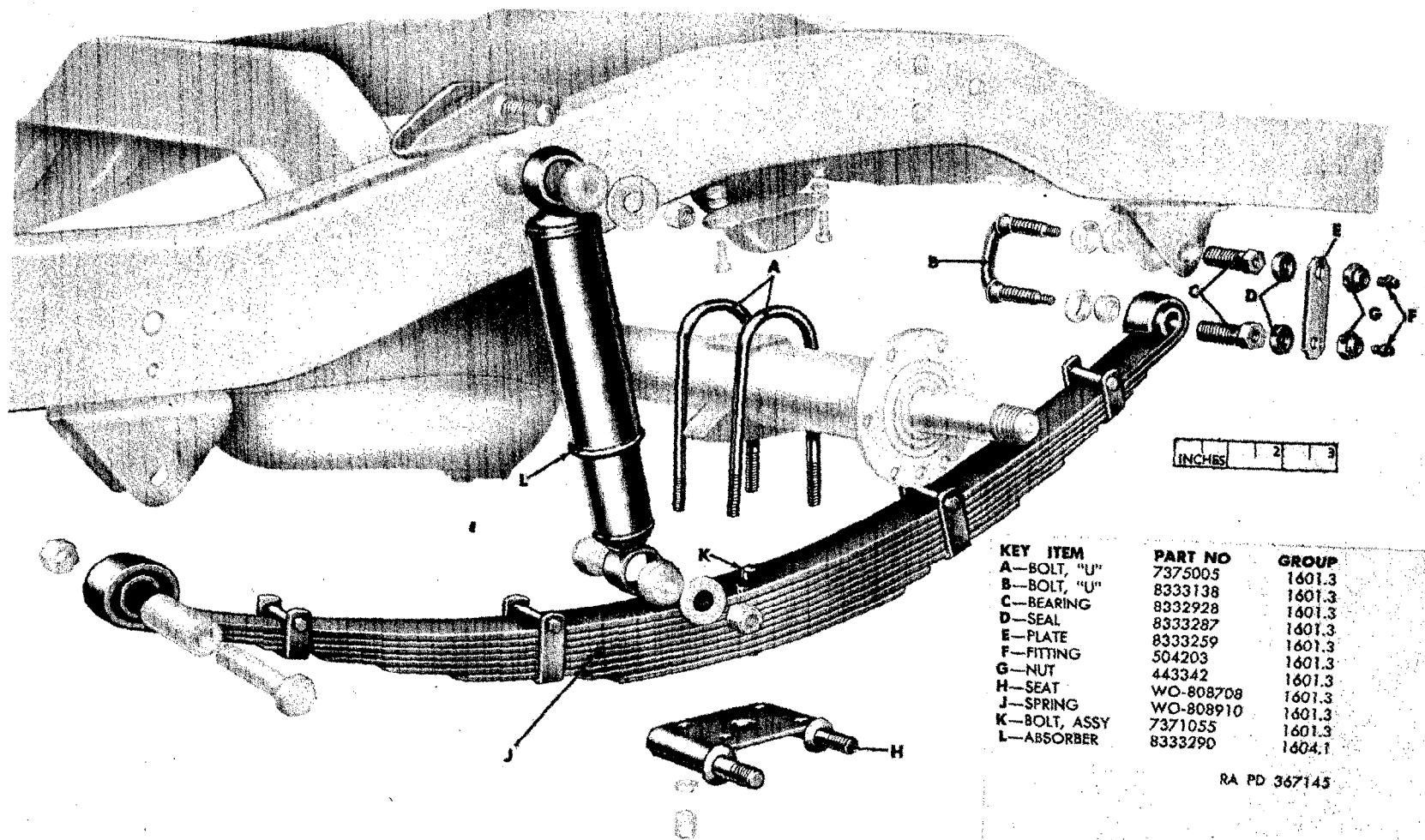
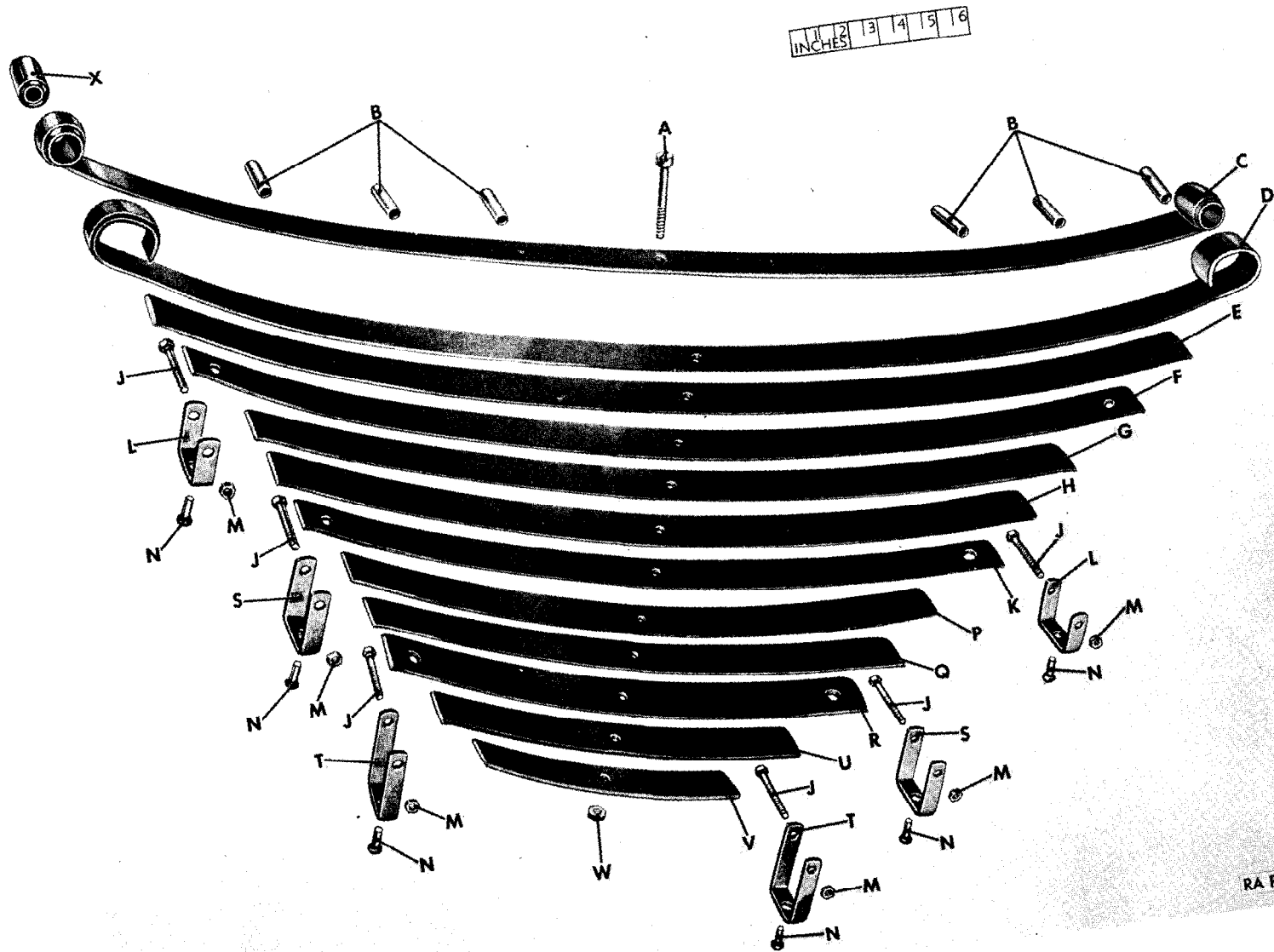

Figure 16-4. Rear spring and shock absorber (M170)

280



RA PD 181646

Figure 16-5. Front spring, assy (8330507) -exploded view

| <i>Key</i> | <i>Item</i> | <i>Part No.</i> |
|------------|----------------|-----------------|
| A | -BOLT..... | 7375006 |
| B | -SPACER..... | MAT-8215-27 |
| C | -LEAF #1..... | MAT-8215-1 |
| D | -LEAF #2..... | MAT-8215-2 |
| E | -LEAF #3..... | MAT-8215-3 |
| F | -LEAF #4..... | MAT-8215-4 |
| G | -LEAF #5..... | MAT-8215-5 |
| H | -LEAF #6..... | MAT-8215-6 |
| J | -BOLT..... | MAT-8215-25 |
| K | -LEAF #7..... | MAT-8215-7 |
| L | -CLIP..... | MAT-8215-22 |
| M | -NUT..... | MAT-8215-26 |
| N | -RIVET..... | MAT-8215-28 |
| P | -LEAF #8..... | MAT-8215-8 |
| Q | -LEAF #9..... | MAT-8215-9 |
| R | -LEAF #10..... | MAT-8215-10 |
| S | -CLIP..... | MAT-8215-23 |
| T | -CLIP..... | MAT-8215-24 |
| U | -LEAF #11..... | MAT-8215-11 |
| V | -LEAF #12..... | MAT-8215-12 |
| W | -NUT..... | 120368 |
| X | -BEARING..... | 8329602 |

Note: All parts listed are in group 1601.1.
Item X not part of assy.

Figure 16-5. Front spring, assy (8330507)—exploded view—legend

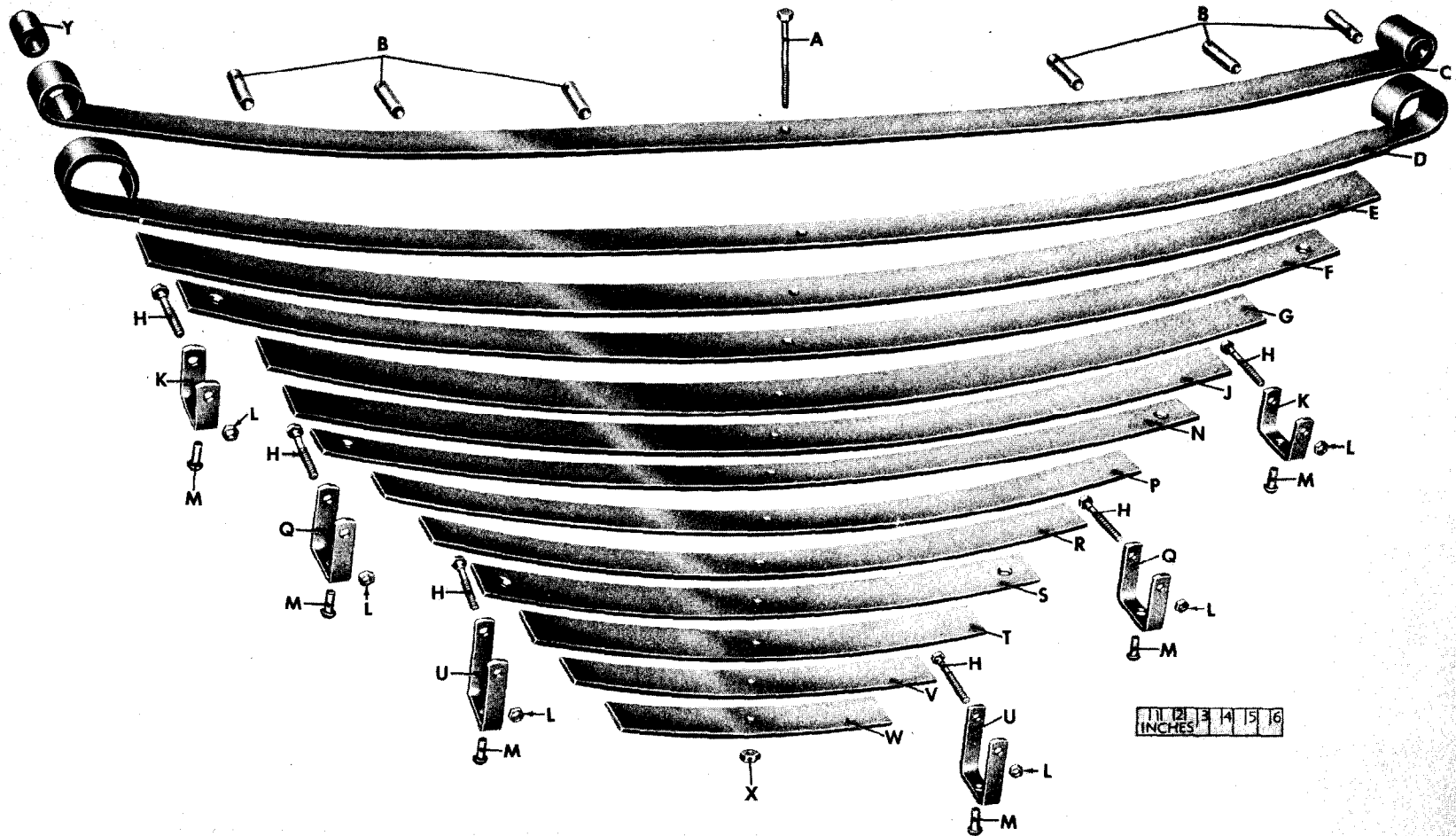

KEY ITEM

A—BOLT
 B—SPACER
 C—LEAF #1
 D—LEAF #2
 E—LEAF #3
 F—LEAF #4
 G—LEAF #5
 H—BOLT
 J—LEAF #6

PART NO

8331239
 MAT-8216-27
 MAT-8216-1
 MAT-8216-2
 MAT-8216-3
 MAT-8216-4
 MAT-8216-5
 MAT-8216-25
 MAT-8216-6

KEY ITEM

K—CLIP
 L—NUT
 M—RIVET
 N—LEAF #7
 P—LEAF #8
 Q—CLIP
 R—LEAF #9
 S—LEAF #10
 T—LEAF #11

PART NO

MAT-8216-22
 MAT-8216-26
 MAT-8216-28
 MAT-8216-7
 MAT-8216-8
 MAT-8216-23
 MAT-8216-9
 MAT-8216-10
 MAT-8216-11

KEY ITEM

U—CLIP
 V—LEAF #12
 W—LEAF #13
 X—NUT
 Y—BEARING

NOTE: ALL PARTS LISTED ARE
 IN GROUP 1601.3
 ITEM Y NOT PART OF ASSY

PART NO

MAT-8216-24
 MAT-8216-12
 MAT-8216-13
 120368
 8329602

1 1/16 1/8 3/16 1/4 5/16 3/8
 INCHES

RA PD 181677

Figure 16-6. Rear spring, assy (8330508)—exploded view

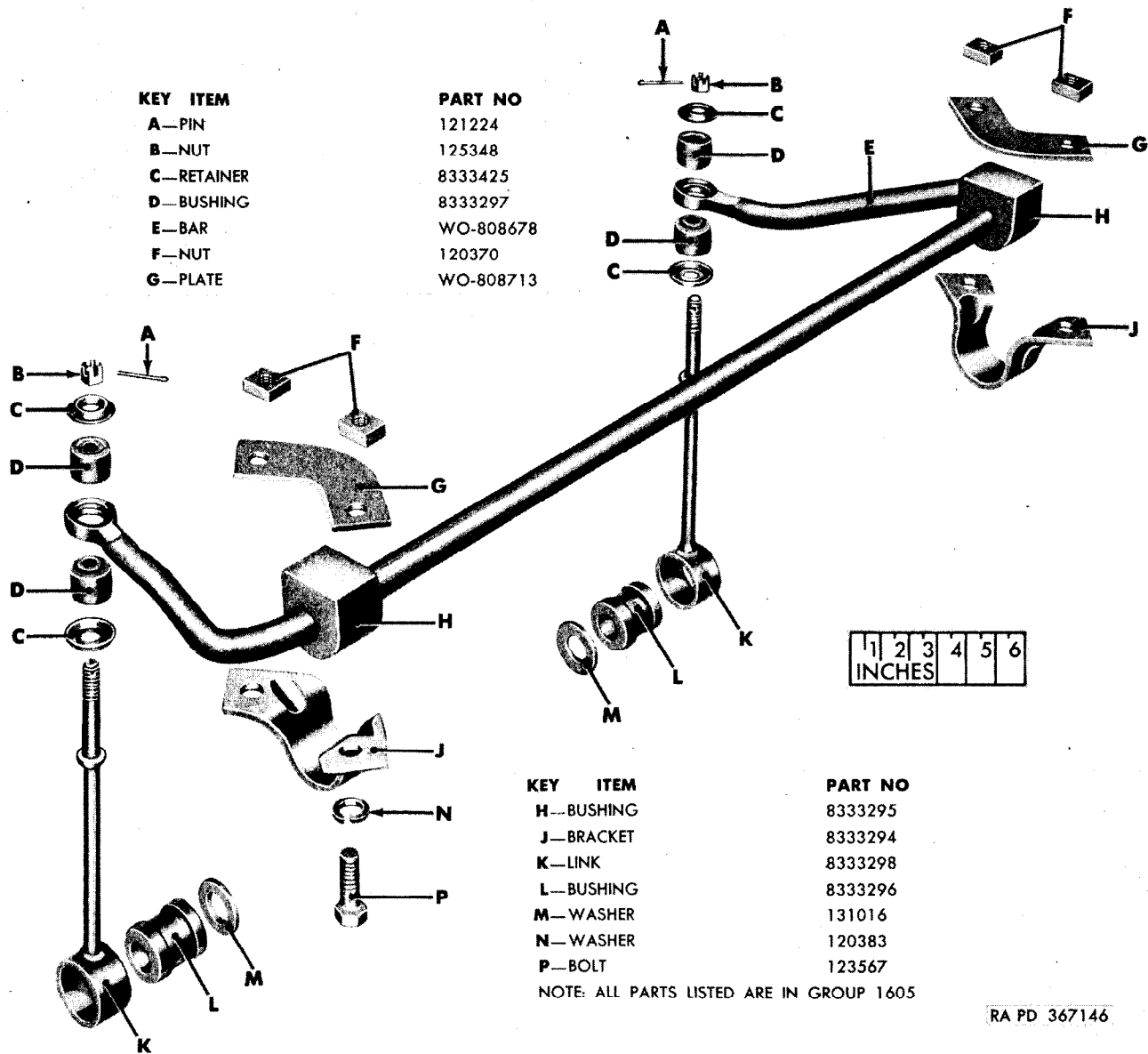

RA PD 367146

Figure 16-7. Front stabilizer (M170)—exploded view

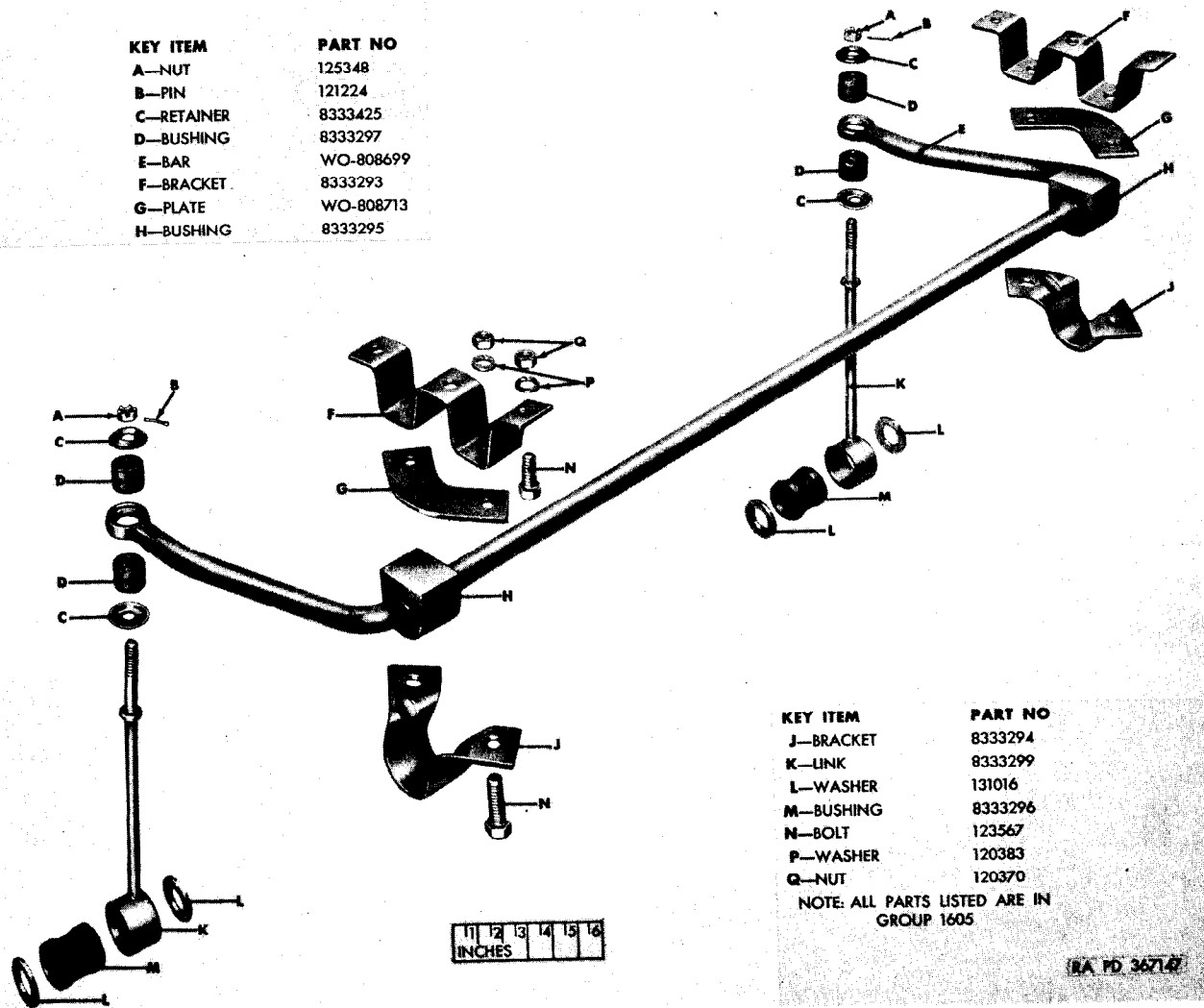

Figure 16-8. Rear stabilizer (M170)—exploded view

| (1) ILLUSTRATION NO. | (2) REFER- ENCE SYMBOLS | (3) FEDERAL STOCK NO. | (4) ORDNANCE STOCK NO. | (5) MFR'S PART NO. | (6) ORDNANCE PART NO. | (7) DESCRIPTION | (8) QUANTITY INCOR- PORATED IN UNIT | (9) UNIT OF ISSUE |
|---|----------------------------------|-----------------------------|------------------------------|---|-----------------------------|---|---|----------------------------|
| GROUP 16—SPRINGS AND SHOCK ABSORBERS | | | | | | | | |
| 1601.1—FRONT SPRINGS | | | | | | | | |
| 16-5 | | | G758-8329602 | WO-806909 | 8329602 | BEARING, bushing type, silent block | 2 | ea |
| | | 3120-769-7598 | G740-7697598 | WO-801244 | 7697598 | BEARING, bushing type, shackle right (front end of right spring (2), front end left front spring (1)) (used on vehicles through serial no. 11440) | 3 | ea |
| | | 3120-769-7596 | G740-7697596 | WO-801245 | 7697596 | BEARING, bushing type, shackle left (front end of front left spring) (used on vehicles through serial no. 11440) | 1 | ea |
| 16-1, 3 | | | G758-8332928 | WO-809807 | 8332928 | BEARING, bushing type, spring shackle, RH thread (used on vehicles after serial no. 11440) | 4 | ea |
| 16-3 | | | G758-8329649 | WO-118952 | 8329649 | BOLT, center, front spring, $\frac{5}{16}$ -24NF-3 x $2\frac{1}{4}$ (super- seded by BOLT 7371055) (M170) | 2 | ea |
| 16-5 | | 5305-737-5006 | G740-7375006 | WO-116715 | 7375006 | BOLT, center, front spring, S, $\frac{5}{16}$ -24NF-3 x $2\frac{3}{4}$ (for 12 leaf) (superseded by BOLT 7371055) | 2 | ea |
| | | | G503-7371055 | | 7371055 | BOLT, center, w/NUT, assy, $\frac{5}{16}$ -24NF x $2\frac{3}{4}$ (super- sedes BOLT 7375006 and 8329649, NUT 103025 and 120368) | 2 | ea |
| 16-3 | H1 | | H001-4167560 | | 103025 | NUT, PLAIN, hex, lt, s-fin, S, $\frac{5}{16}$ -24NF-2 (super- seded by BOLT 7371055) (M170) | 2 | ea |
| 16-5 | H1 | 012-0368 | H001-4167561 | | 120368 | NUT, plain, hex, reg, s-fin, S, $\frac{5}{16}$ -24NF-2 (superseded by BOLT 7371055) (M38A1) | 2 | ea |
| 16-5 | | | | MAT-8215-25 MAT-2816-25 WO-120179 | | BOLT, hex-hd, spec, S, $\frac{5}{16}$ -18NC x $2\frac{1}{2}$ (clip rebound) | 12 | ea |
| 16-1 | | 5305-174-4195 | G758-8332529 | WO-809236 | 8332529 | BOLT, mach, hex-hd, S, cd- or zn-pltd, $\frac{1}{16}$ -20NF-3 x 3 (spring pivot) | 2 | ea |
| 16-1 | H1 | 044-2830 | H101-0442830 | | 442830 | NUT, self-lkg, S, cd- or zn-pltd, $\frac{1}{16}$ -20NF-2 (front spring attaching) | 2 | ea |
| 16-3 | | | G758-8333286 | WO-808988 | 8333286 | BOLT, "U", front spring (right spring over axle tube) (M170) | 1 | ea |
| | H1 | 013-1100 | G503-7371061 | WO-339372 | 7371061 | NUT, PLAIN, sp, hex, $\frac{1}{16}$ -20NF-2 | 2 | ea |
| | | | H101-0131100 | | 131100 | WASHER, lock, hv, S, cd- or zn-pltd, $\frac{1}{16}$ in. | 2 | ea |
| 16-3 | | | G758-8333285 | WO-A1097 | 8333285 | BOLT, "U", front spring (left spring, over axle tube (2), right spring, over axle tube (1)) (M170) | 3 | ea |
| | H1 | | G503-7371061 | WO-339372 | 7371061 | NUT, PLAIN, sp, hex, $\frac{1}{16}$ -20NF-2 | 6 | ea |
| | | | H101-0131100 | | 131100 | WASHER, lock, hv, S, cd- or zn-pltd, $\frac{1}{16}$ in. | 6 | ea |
| 16-1 | | | G758-8330509 | WO-808460 | 8330509 | BOLT, "U", right spring and left spring (over axle tube) | 3 | ea |
| 16-1 | | | G758-8330510 | WO-808461 | 8330510 | BOLT, "U", right spring (over axle tube) | 1 | ea |
| 16-1 | | 5310-495-9542 | G503-7371061 | WO-339372 | 7371061 | NUT, PLAIN, HEXAGON, $\frac{1}{16}$ -20NF-2 | 8 | ea |
| 16-1 | H1 | 013-1100 | H101-0131100 | | 131100 | WASHER, lock, hv, S, cd- or zn-pltd, $\frac{1}{16}$ in. | 8 | ea |

1601.1

| (1) | (2) | (3) | (4) | (5) | (6) | (7) | (8) | (9) |
|------------------|-------------------|-------------------|--------------------|---|-------------------|--|-------------------------------|---------------|
| ILLUSTRATION NO. | REFERENCE SYMBOLS | FEDERAL STOCK NO. | ORDNANCE STOCK NO. | MFR'S PART NO. | ORDNANCE PART NO. | DESCRIPTION | QUANTITY INCORPORATED IN UNIT | UNIT OF ISSUE |
| | | | | | | GROUP 16—SPRINGS AND SHOCK ABSORBERS —Continued | | |
| | | | | | | 1601.1—FRONT SPRINGS—Continued | | |
| 16-3 | | | G758-8333138 | WO-810579 | 8333138 | BOLT, "U", spring shackle, RH thread (used on M38A1 vehicles serial No. 11440) (M170) | 2 | ea |
| 16-3 | | | | | 443342 | NUT, LOCK, hex-hd, S, cd- or zn-pltd, $\frac{5}{16}$ -18NF (Huglock type) | 4 | ea |
| | | | G758-8329600 | WO-805580 | 8329600 | BUMPER, axle, front (superseded by BUMPER WO-802454) | 2 | ea |
| 16-1 | | | | WO-802454 | | BUMPER, axle, front (supersedes BUMPER 8329600) | 2 | ea |
| 16-1 | H1 | | H101-9409102 | | 9409102 | BOLT, mach, hex-hd, w/spring LOCK WASHER, S, cd- or zn-pltd, $\frac{5}{16}$ -24NF-2 x $\frac{3}{4}$ | 4 | ea |
| 16-5 | | | | MAT-8215-23 WO-120184 | | CLIP, rebound, front, intermediate | 4 | ea |
| | | | G758-8331235 | WO-119944 | 8331235 | CLIP, rebound, front, intermediate, assy (includes CLIP, BOLT, SPACER, and NUT) | 4 | ea |
| 16-5 | | | | MAT-8215-24 WO-120185 | | CLIP, rebound, front, large | 4 | ea |
| | | | G758-8331232 | WO-119914 | 8331232 | CLIP, rebound, front, large, assy (includes CLIP, BOLT, SPACER, and NUT) | 4 | ea |
| | | | G758-8329601 | WO-806968 | 8329601 | CLIP, rebound, front, assy (large) (includes CLIP, BOLT, SPACER, and NUT) (M170) | 4 | ea |
| 16-5 | | | | MAT-8215-22 WO-120183 | | CLIP, rebound, front, small | 4 | ea |
| | | | G758-8331234 | WO-119913 | 8331234 | CLIP, rebound, front, small, assy (includes CLIP, BOLT, SPACER, and NUT) | 4 | ea |
| | H16 | 050-4208 | H016-0504208 | | 504208 | CLIP, rebound, front, small, assy (includes CLIP, BOLT, SPACER, and NUT) (M170) | 4 | ea |
| | | | | | | FITTING, lubr, hyd, type, S, cd- or zn-pltd, male thd, $\frac{1}{8}$ -27NPT (ball check valve) (used on vehicles through serial No. 11440) | 4 | ea |
| 16-1, 3 | H16 | 050-4203 | H016-0504203 | | 504203 | FITTING, lubr, hyd, type 1, S, cd- or zn-pltd, $\frac{1}{4}$ -28NF, male (ball check valve) (used on vehicles after serial No. 11440) | 4 | ea |
| 16-5 | | | | MAT-8215-26 MAT-8216-26 WO-120181 | | NUT, hex, S, $\frac{5}{16}$ -18NC (clip rebound) | 12 | ea |
| 16-1, 3 | | | G758-8333259 | WO-810542 | 8333259 | PLATE, side, spring shackle (used on vehicles after serial No. 11440) | 2 | ea |

266

| | | | | | | | | |
|---------|----|---------------|--------------|---|---------|--|----|----|
| 16-1 | | | G503-7735843 | WO-A1252 | 7735843 | RETAINER, shackle grease seal | 4 | ea |
| 16-5 | | | | MAT-8215-28 MAT-8216-28 WO-120182 | | RIVET, button-hd, S (clip rebound) | 12 | ea |
| | HI | 012-4155 | H001-0124155 | | 124155 | SCREW, CAP, HEXAGON-HEAD: low-carb-S, cd- or zn-pltd, 1/16-20UNF-2A x 3 (spring pivot) | 2 | ea |
| 16-1 | | 5330-769-7602 | G740-7697602 | WO-801045 | 7697602 | SEAL, grease, shackle | 4 | ea |
| 16-1, 3 | | | G758-8333287 | WO-811890 | 8333287 | SEAL, spring, shackle (ru) (use on vehicles after serial No. 11440) (M170) | 4 | ea |
| 16-1 | | 2510-769-7601 | G740-7697601 | WO-800821 | 7697601 | SEAT, spring clip, front left, w/SHAFT (welded) (includes SHAFT and WASHER) (M38A1) | 1 | ea |
| | | | | WO-808709 | | SEAT, spring clip, front left, w/SHAFT (welded) (includes SHAFT and WASHER) (M170) | 1 | ea |
| | | 2510-769-7600 | G740-7697600 | WO-800823 | 7697600 | SEAT, spring clip, front right, w/SHAFT (welded) (includes SHAFT and WASHER) (M38A1) | 1 | ea |
| 16-3 | | | | WO-808710 | | SEAT, spring clip, front right, w/SHAFT (welded) (includes SHAFT and WASHER) (M170) | 1 | ea |
| | | 2510-737-1090 | G503-7371090 | WO-A513 | 7371090 | SHACKLE, front, left spring, LH thd (front end left front spring) (used on vehicles through serial no. 11440) | 1 | ea |
| | | 2510-773-5833 | G503-7735833 | WO-A514 | 7735833 | SHACKLE, front, right spring, RH thd (front end right front spring) (used on vehicles through serial no. 11440) | 1 | ea |
| 16-5 | | | | MAT-8215-27 MAT-8216-27 WO-120180 | | SPACER, clip, rebound | 12 | ea |
| | | | G758-8329978 | WO-802825 | 8329978 | SPRING, front, assy (9 leaf) (superseded by SPRING WO-907818) (M170) | 2 | ea |
| 16-3 | | | | WO-907818 | | SPRING, front, assy (9 leaf) (supersedes SPRING 8329978) (M170) | 2 | ea |
| | | | | | 8329649 | Composed of: | | |
| | | | | | 8329601 | 1 BOLT | | |
| | | | | | | 2 CLIP (large) | | |
| | | | | | | 2 CLIP (small) | | |
| | | | | WO-119962 | | 1 LEAF no. 1, 39.25 (between eye centers) | | |
| | | | | WO-120816 | | 1 LEAF no. 2, 39.25 (between eye centers) | | |
| | | | | WO-120817 | | 1 LEAF no. 3, 34.50 | | |
| | | | | WO-119722 | | 1 LEAF no. 4, 30.0 | | |
| | | | | WO-119723 | | 1 LEAF no. 5, 26.0 | | |
| | | | | WO-119724 | | 1 LEAF no. 6, 22.0 | | |
| | | | | WO-119725 | | 1 LEAF no. 7, 18.25 | | |
| | | | | WO-119726 | | 1 LEAF no. 8, 14.0 | | |
| | | | | WO-119727 | | 1 LEAF no. 9, 10.0 | | |
| | | | | WO-119728 | | 1 NUT | | |
| | | | | | 103025 | | | |

1601.1

288

| (1) ILLUSTRATION NO. | (2) REFER- ENCE SYMBOLS | (3) FEDERAL STOCK NO. | (4) ORDNANCE STOCK NO. | (5) MFR'S PART NO. | (6) ORDNANCE PART NO. | (7) DESCRIPTION | (8) QUANTITY INCOR- PORATED IN UNIT | (9) UNIT OF ISSUE |
|--|----------------------------------|-----------------------------|------------------------------|--------------------------|--|--|---|----------------------------|
| GROUP 16—SPRINGS AND SHOCK ABSORBERS —Continued | | | | | | | | |
| 1601.1—FRONT SPRINGS—Continued | | | | | | | | |
| 16-5 | | | G758-8330507 | MAT-8215 WO-808458 | 8330507 | SPRING, front, assy (12 leaf) (M38A1) | 2 | ea |
| | | | | | 7375006 8331235 8331232 8331234 | Composed of: 1 BOLT 2 CLIP, intermediate 2 CLIP, large 2 CLIP, small | | |
| 16-5 | | | | MAT-8215-1 WO-119898 | | 1 LEAF, no. 1, 39.62 (between eye centers) | | |
| 16-5 | | | | MAT-8215-2 WO-119899 | | 1 LEAF, no. 2, 39.38 (between eye centers) | | |
| 16-5 | | | | MAT-8215-3 WO-119900 | | 1 LEAF, no. 3, 37.25 | | |
| 16-5 | | | | MAT-8215-4 WO-119901 | | 1 LEAF, no. 4, 34.38 | | |
| 16-5 | | | | MAT-8215-5 WO-119902 | | 1 LEAF, no. 5, 29.88 | | |
| 16-5 | | | | MAT-8215-6 WO-119903 | | 1 LEAF, no. 6, 28.00 | | |
| 16-5 | | | | MAT-8215-7 WO-119904 | | 1 LEAF, no. 7, 25.88 | | |
| 16-5 | | | | MAT-8215-8 WO-119905 | | 1 LEAF, no. 8, 21.88 | | |
| 16-5 | | | | MAT-8215-9 WO-119906 | | 1 LEAF, no. 9, 20.00 | | |
| 16-5 | | | | MAT-8215-10 WO-119907 | | 1 LEAF, no. 10, 18.25 | | |
| 16-5 | | | | MAT-8215-11 WO-119908 | | 1 LEAF, no. 11, 14.00 | | |
| 16-5 | | | | MAT-8215-12 WO-119909 | | 1 LEAF, no. 12, 10.00 | | |
| 16-5 | | | | | 120368 | 1 NUT | | |
| 16-1 | | | G758-8333767 | WO-808467 | 8333767 | SPRING, front, w/BEARING, assy (M38A1) | 2 | ea |
| | | | G758-8333019 | WO-802954 | 8333019 | SPRING, front, w/BEARING, assy (superseded by SPRING WO-907838) (M170) | 2 | ea |
| | | | | WO-907838 | | SPRING, front, w/BEARING, assy (supersedes SPRING 8333019) | 2 | ea |

| | | | | | 1601.3—REAR SPRINGS | | | |
|------------|----|---------------|------------------------------|---|---------------------|---|---|----|
| | | 3120-769-7598 | G740-7697598 | WO-801244 | 7697598 | BEARING, bushing type, shackle, right (rear end left rear spring (2), rear end right rear spring (1)) (used on vehicles through serial no. 11440) | 3 | ea |
| | | 3120-769-7596 | G740-7697596 | WO-801245 | 7697596 | BEARING, bushing type, shackle, left (rear end right rear spring) (used on vehicles through serial no. 11440) | 1 | ea |
| 16-2, 6 | | | G758-8329602 | WO-806909 | 8329602 | BEARING, bushing type, silent block | 2 | ea |
| 16-1, 2, 4 | | | G758-8332928 | WO-809807 | 8332928 | BEARING, bushing type, spring shackle, RH thread (rear end, left and right rear spring) (used on vehicles after serial no. 11440) | 4 | ea |
| | | | G740-7375006 | WO-116715 | 7375006 | BOLT, center, rear spring, $\frac{5}{16}$ -24NF-3 x 2 $\frac{3}{4}$ (superseded by BOLT 7371055) (M170) | 2 | ea |
| | H1 | 010-3025 | H001-4167560 | | 103025 | NUT, plain, hex, lt, s-fin, S, $\frac{5}{16}$ -24NF-2 (superseded by BOLT 7371055) | 2 | ea |
| 16-6 | | | G758-8331239 | WO-119935 | 8331239 | BOLT, center, rear spring, S, $\frac{5}{16}$ -24NF-3 x 3 $\frac{1}{4}$ (for 13 leaf) (superseded by BOLT 7371055) (M38A1) | 2 | ea |
| 16-6 | H1 | 012-0368 | H001-4167561 | | 120368 | NUT, plain, hex, reg, s-fin, $\frac{5}{16}$ -24NF-2 (superseded by BOLT 7371055) | 2 | ea |
| 16-4 | | | G503-7371055 | WO-116716 | 7371055 | BOLT, center, rear spring, w/NUT, assy, $\frac{5}{16}$ -24NF x 2 $\frac{3}{4}$ (supersedes BOLT 7375006, 8331239, NUT 120368, 103025) (M170) | 2 | ea |
| 16-2 | H1 | 044-2830 | G758-8332529 H101-0442830 | WO-809236 | 8332529 442830 | BOLT, MACH, hex-hd, S, cd- or zn-pltd, $\frac{3}{16}$ -20NF-3 x 3 | 2 | ea |
| 16-6 | | | | MAT-8216-25 MAT-8215-25 WO-120179 | | NUT, self-lkg, hex, S, cd- or zn-pltd, $\frac{1}{16}$ -20NF-2 (rear spring attaching) | 2 | ea |
| 16-2 | | | G758-8330511 | WO-808462 | 8330511 | BOLT, "U" (M38A1) | 4 | ea |
| 16-2 | | 5810-495-9542 | G503-7371061 | WO-339372 | 7371061 | NUT, PLAIN, hex, $\frac{1}{16}$ -20NF-2 | 8 | ea |
| 16-2 | H1 | 013-1100 | H101-0131100 | | 131100 | WASHER, lock, hv, S, cd- or zn-pltd, $\frac{1}{16}$ in. | 8 | ea |
| 16-4 | | | G740-7375005 | WO-642987 | 7375005 | BOLT, "U" (M170) | 4 | ea |
| | | | G503-7371061 | WO-339372 | 7371061 | NUT, sp, hex, $\frac{1}{16}$ -20NF-2 | 8 | ea |
| 16-4 | H1 | 013-1100 | H101-0131100 | | 131100 | WASHER, lock, hv, S, cd- or zn-pltd, $\frac{1}{16}$ in. | 8 | ea |
| 16-4 | | | G758-8333138 | WO-810579 | 8333138 | BOLT, "U", spring shackle, RH thread (used on M38A1 vehicles after serial no. 11440) (M170) | 2 | ea |
| 16-4 | | | | | 443342 | NUT, lock hex-hd, S, cd- or zn-pltd, $\frac{5}{16}$ -18NF ("Hug-lock" type) | 4 | ea |
| | | | G758-8329600 | WO-805580 | 8329600 | BUMPER, axle, rear (superseded by BUMPER WO-802454) | 2 | ea |
| 16-2 | | | | WO-802454 | | BUMPER, axle, rear (supersedes BUMPER 8329600) | 2 | ea |
| 16-2 | H1 | | H101-9409102 | | 9409102 | BOLT, mach, assembled washer, hex-hd, split lock washer, S, cd- or zn-pltd, $\frac{5}{16}$ -24UNF-2A x $\frac{3}{4}$ (rear axle bumper) | 4 | ea |
| 16-2 | H1 | 012-0368 | H001-4167561 | | 120368 | NUT, plain, hex, reg, s-fin, S, $\frac{5}{16}$ -24NF-2 (rear axle bumper) | 4 | ea |

1601.3

290

| (1) ILLUSTRATION NO. | (2) REFER- ENCE SYMBOLS | (3) FEDERAL STOCK NO. | (4) ORDNANCE STOCK NO. | (5) MFR'S PART NO. | (6) ORDNANCE PART NO. | (7) DESCRIPTION | (8) QUANTITY INCOR- PORATED IN UNIT | (9) UNIT OF ISSUE |
|--|----------------------------------|-----------------------------|------------------------------|--|-----------------------------|--|---|----------------------------|
| GROUP 16--SPRINGS AND SHOCK ABSORBERS | | | | | | | | |
| -Continued | | | | | | | | |
| 1601.3--REAR SPRINGS--Continued | | | | | | | | |
| 16-6 | | | | MAT-8216-23 WO-120187 | | CLIP, rebound, rear, intermediate..... | 4 | ea |
| | | | G758-8331238 | WO-119945 | 8331238 | CLIP, rebound, rear, intermediate, assy (includes CLIP, BOLT, SPACER, and NUT) | 4 | ea |
| 16-6 | | | | MAT-8216-24 WO-120188 | | CLIP, rebound, rear, large..... | 4 | ea |
| | | | G758-8331236 | WO-119934 | 8331236 | CLIP, rebound, rear, large, assy (includes CLIP, BOLT, SPACER, and NUT) (M38A1) | 4 | ea |
| | | | G758-8329603 | WO-806969 | | CLIP, rebound, rear, large, assy (includes CLIP, BOLT, SPACER, and NUT) (M170) | 4 | ea |
| | | | G758-8331237 | WO-119933 | 8331237 | CLIP, rebound, rear, small, assy (includes CLIP, BOLT, SPACER, and NUT) (M38A1) | 4 | ea |
| | | | | WO-119963 | | CLIP, rebound, rear, small assy (includes CLIP, BOLT, SPACER, and NUT) (M170) | 4 | ea |
| 16-6 | | | | MAT-8216-22 WO-120186 | | CLIP, rebound, rear, small..... | 4 | ea |
| | H16 | 050-4208 | H016 0504208 | | 504208 | FITTING, LUBRICATION, hyd, surface, check, stght, 1/8-27NPTF short male (ball check valve) (used on vehicles through serial No. 11440) | 4 | ea |
| 16-2, 4 | H16 | 050-4203 | H016-0504203 | | 504203 | FITTING, LUBRICATION, hyd, stght, 1/4-28NF, male (ball check valve) (used on vehicles after serial No. 11440) | 4 | ea |
| 16-6 | | | | MAT-8216-26 MAT-8215-26 WO-120181 WO-808707 | | NUT, hex, S, 5/16-18NC (clip rebound)..... | 12 | ea |
| | | 2510-737-5001 | G740-7375001 | WO-801736 | 7375001 | PLATE, left spring clip, w/SHAFT (welded) (includes SHAFT and WASHER) (M170) | 1 | ea |
| | | | | | | PLATE, right spring clip, w/SHAFT (welded) (includes SHAFT and WASHER) (M38A1) | 1 | ea |
| 16-2, 4 | | | G758-8333259 | WO-810542 | 8333259 | PLATE, side, spring shackle (used on vehicles after serial No. 11440) | 2 | ea |
| 16-2 | | 2510-773-5843 | G503-7735843 | WO-A1252 | 7735843 | RETAINER, grease seal, shackle..... | 4 | ea |
| 16-6 | | | | MAT-8215-28 MAT-8216-28 WO-120182 | | RIVET, button-hd, S (clip rebound)..... | 12 | ea |
| 16-2 | H1 | 012-4155 | H101-0124155 | | 124155 | SCREW, CAP, HEXAGON-HEAD, low-carbon-S, cd- or zn-pltd, 1/16-20UNF-2A x 3 (spring pivot) | 2 | ea |

| | | | | | | | |
|---------|---------------|--------------|-------------|---------|--|----|----|
| 16-2 | 5330-769-7602 | G740-7697602 | WO-801045 | 7697602 | SEAL, grease, shackle | 4 | ea |
| 16-2, 4 | | G758-8333287 | WO-811890 | 8333287 | SEAL, spring shackle (ru) (used on vehicles after serial No. 11440) | 4 | ea |
| 16-2 | | | WO-801735 | 7375000 | SEAT, left spring clip, w/SHAFT (welded) (includes SHAFT and WASHER) (M38A1) | 1 | ea |
| 16-4 | | | WO-808708 | | SEAT, right spring clip, w/SHAFT (welded) (includes SHAFT and WASHER) (M170) | 1 | ea |
| | 2510-737-1090 | G503-7371090 | WO-A513 | 7371090 | SHACKLE, rear, left spring, LH thd (rear end, rear right spring) (used on vehicles through serial No. 11440) | 1 | ea |
| | 2510-773-5833 | G503-7735833 | WO-A514 | 7735833 | SHACKLE, rear, left spring, RH thd (rear end, rear left spring) (used on vehicles through serial No. 11440) | 1 | ea |
| 16-6 | | | MAT-8215-27 | | SPACER, clip, rebound | 12 | ea |
| | | | MAT-8216-27 | | | | |
| | | | WO-120180 | | | | |
| 16-6 | | G758-8330508 | MAT-8216 | 8330508 | SPRING, rear, assy (13 leaves) (M38A1) | 2 | ea |
| | | | WO-808459 | | Composed of: | | |
| | | | | 8331239 | 1 BOLT | | |
| | | | | 8331236 | 2 CLIP (large) | | |
| | | | | 8331237 | 2 CLIP (small) | | |
| | | | | 8331238 | 2 CLIP (intermediate) | | |
| 16-6 | | | MAT-8216-1 | | 1 LEAF, No. 1, 46.12 (between eye centers) | | |
| | | | WO-119920 | | | | |
| 16-6 | | | MAT-8216-2 | | 1 LEAF, No. 2, 45.88 (between eye centers) | | |
| | | | WO-119921 | | | | |
| 16-6 | | | MAT-8216-3 | | 1 LEAF, No. 3, 43.50 | | |
| | | | WO-119922 | | | | |
| 16-6 | | | MAT-8216-4 | | 1 LEAF, No. 4, 36.00 | | |
| | | | WO-119923 | | | | |
| 16-6 | | | MAT-8216-5 | | 1 LEAF, No. 5, 36.00 | | |
| | | | WO-119924 | | | | |
| 16-6 | | | MAT-8216-6 | | 1 LEAF, No. 6, 34.00 | | |
| | | | WO-119925 | | | | |
| 16-6 | | | MAT-8216-7 | | 1 LEAF, No. 7, 32.00 | | |
| | | | WO-119926 | | | | |
| 16-6 | | | MAT-8216-8 | | 1 LEAF, No. 8, 28.00 | | |
| | | | WO-119927 | | | | |
| 16-6 | | | MAT-8216-9 | | 1 LEAF, No. 9, 24.50 | | |
| | | | WO-119928 | | | | |
| 16-6 | | | MAT-8216-10 | | 1 LEAF, No. 10, 21.00 | | |
| | | | WO-119929 | | | | |
| 16-6 | | | MAT-8216-11 | | 1 LEAF, No. 11, 17.31 | | |
| | | | WO-119930 | | | | |
| 16-6 | | | MAT-8216-12 | | 1 LEAF, No. 12, 14.00 | | |
| | | | WO-119931 | | | | |
| 16-6 | | | MAT-8216-13 | | 1 LEAF, No. 13, 10.50 | | |
| | | | WO-119932 | | | | |
| | | | | 120368 | 1 NUT | | |

| (1) ILLUSTRATION NO. | (2) REFER- ENCE SYMBOLS | (3) FEDERAL STOCK NO. | (4) ORDNANCE STOCK NO. | (5) MFR'S PART NO. | (6) ORDNANCE PART NO. | (7) DESCRIPTION | (8) QUANTITY INCOR- PORATED IN UNIT | (9) UNIT OF ISSUE |
|---|----------------------------------|-----------------------------|------------------------------|-----------------------|-----------------------------|--|---|----------------------------|
| GROUP 16—SPRINGS AND SHOCK ABSORBERS —Continued | | | | | | | | |
| 1601.3—REAR SPRINGS—Continued | | | | | | | | |
| 16-4 | | | | WO-808910 | | SPRING, rear, assy (11 leaf) (M170)..... | 2 | ea |
| | | | | | 7375006 | Composed of: | | |
| | | | | WO-806969 | | 1 BOLT | | |
| | | | | WO-119968 | | 2 CLIP | | |
| | | | | WO-120831 | | 2 CLIP | | |
| | | | | WO-120832 | | 1 LEAF, No. 1, 46.0 (between eye centers) | | |
| | | | | WO-119710 | | 1 LEAF, No. 2, 46.0 (between eye centers) | | |
| | | | | WO-119711 | | 1 LEAF, No. 3, 41.0 | | |
| | | | | WO-119712 | | 1 LEAF, No. 4, 36.0 | | |
| | | | | WO-119714 | | 1 LEAF, No. 5, 32.0 | | |
| | | | | WO-119715 | | 1 LEAF, No. 6, 28.0 | | |
| | | | | WO-119716 | | 1 LEAF, No. 7, 24.50 | | |
| | | | | WO-119717 | | 1 LEAF, No. 8, 21.0 | | |
| | | | | WO-119718 | | 1 LEAF, No. 9, 17.5 | | |
| | | | | WO-119719 | | 1 LEAF, No. 10, 14.0 | | |
| | | | | | 103025 | 1 LEAF, No. 11, 10.5 | | |
| | | | | | | 1 NUT | | |
| 16-2 | | | G758-8333800 | WO-808466 | 8333800 | SPRING, rear, w/BEARING, assy (M38A1)..... | 2 | ea |
| | | | G758-8333288 | WO-808906 | 8333288 | SPRING, rear, w/BEARING, assy (M170)..... | 2 | ea |
| 1604.1—SHOCK ABSORBERS | | | | | | | | |
| 16-1 | | | G758-8330512 | MAE-18302 | 8330512 | ABSORBER, shock, front, assy (Monroe) (M38A1)..... | 2 | ea |
| | | | | WO-808450 | | | | |
| 16-3 | | | G758-8333289 | WO-809149 | 8333289 | ABSORBER, shock, front, assy (Monroe) (M170)..... | 2 | ea |
| 16-2 | | | G758-8330513 | MAE-18303 | 8330513 | ABSORBER, shock, rear, assy (Monroe) (M38A1)..... | 2 | ea |
| | | | | WO-808451 | | | | |
| 16-4 | | | G758-8333290 | WO-809161 | 8333290 | ABSORBER, shock, rear, assy (Monroe) (M170)..... | 2 | ea |
| 16-1, 2 | | 3120-734-3032 | G503-7343032 | WO-637936 | 7343032 | BUSHING, mtg pin (ru)..... | 16 | ea |
| 16-1, 2 | H1 | 044-2830 | H101-0442830 | | 442830 | NUT, self-lkg, hex, S, cd- or zn-pltd. 1/6-20NF..... | 8 | ea |
| 16-1, 2 | H1 | 012-0389 | H001-7045621 | | 120389 | WASHER, FLAT, 1/2 ID, 1 1/4 OD, 0.083 thk..... | 8 | ea |
| 1605—STABILIZER BARS (M170) | | | | | | | | |
| 16-7 | | | | WO-808678 | | BAR, stabilizer, front..... | 1 | ea |
| 16-7 | | | | WO-811913 | | BAR, stabilizer, front, assy (complete)..... | 1 | ea |
| | | | | | | Composed of: | | |

293

1605

| | | | | | | | |
|---------|----|---------------|--------------|---------|---|--------|----------|
| | | | | 8333291 | 1 BAR, w/BUSHING | | |
| | | | | 8333297 | 4 BUSHING | | |
| | | | | 8333298 | 2 LINK | | |
| | | | | 125348 | 2 NUT | | |
| | | | | 121224 | 2 PIN | | |
| | | | | 8333425 | 4 RETAINER | | |
| 16-8 | | | WO-808699 | | BAR, stabilizer, rear | 1 | ea |
| 16-8 | | | WO-811914 | | BAR, stabilizer, rear, assy (complete) | 1 | ea |
| | | | | | Composed of: | | |
| | | | | 8333292 | 1 BAR w/BUSHING | | |
| | | | | 8333297 | 4 BUSHING | | |
| | | | | 8333299 | 2 LINK | | |
| | | | | 125348 | 2 NUT | | |
| | | | | 121224 | 2 PIN | | |
| | | | | 8333425 | 4 RETAINER | | |
| | | G758-8333291 | WO-808672 | 8333291 | BAR, stabilizer, w/BUSHING, assy (front) | 1 | ea |
| | | | WO-808678 | | Composed of: | | |
| | | | | | 1 BAR | | |
| | | | | 8333295 | 2 BUSHING | | |
| | | G758-8333292 | WO-808693 | 8333292 | BAR, stabilizer, w/BUSHING, assy (rear) | 1 | ea |
| | | | WO-808699 | | Composed of: | | |
| | | | | | 1 BAR | | |
| | | | | 8333295 | 2 BUSHING | | |
| 16-7, 8 | | G758-8333294 | WO-808714 | 8333294 | BRACKET, stabilizer mounting bar (front and rear) | 4 | ea |
| 16-7, 8 | H1 | 012-3567 | H001-5422921 | 123567 | BOLT, mach, hex-hd, S, cd- or zn-pltd, 1/16-20NF-3 x 1 (mounting bracket to frame (4), mounting bracket to support bracket (4)) | 8 8 | ea ea |
| 16-7, 8 | H1 | 012-0370 | H001-4167641 | 120370 | NUT, PLAIN, hex, lt, s-fin, S, cd- or zn-pltd, 1/16- 20NF-2 | 8 | ea |
| 16-7, 8 | H1 | 5310-012-0383 | H001-7025771 | 120383 | WASHER, LOCK, med, S, cd- or zn-pltd, 1/16 in. | 8 | ea |
| 16-8 | | G758-8333293 | WO-811545 | 8333293 | BRACKET, stabilizer support (rear) | 2 | ea |
| 16-8 | H1 | 012-3567 | H001-5422921 | 123567 | BOLT, mach, hex-hd, S, cd- or zn-pltd, 1/16-20NF-2 x 1 | 6 | ea |
| 16-8 | H1 | 012-0370 | H001-4167641 | 120370 | NUT, PLAIN, hex, lt, s-fin, S, cd- or zn-pltd, 1/16- 20NF-2 | 6 | ea |
| 16-8 | H1 | 5310-012-0383 | H001-7025771 | 120383 | WASHER, LOCK, med, S, cd- or zn-pltd, 1/16 in. (sup- port bracket to frame side rail) | 6 | ea |
| 16-7, 8 | | G758-8333296 | WO-808703 | 8333296 | BUSHING, RUBBER, stabilizer link | 4 | ea |
| 16-7, 8 | | G758-8333297 | WO-642943 | 8333297 | BUSHING, RUBBER, stabilizer link | 8 | ea |
| 16-7, 8 | | G758-8333295 | WO-808668 | 8333295 | BUSHING, stabilizer | 4 | ea |
| 16-7 | | G758-8333298 | WO-808716 | 8333298 | LINK, stabilizer (front) | 2 | ea |
| 16-7 | H1 | 012-5348 | H101-0125348 | 125348 | NUT, SLOTTED, HEXAGON, lt, thk, s-fin, S, cd- or zn-pltd, 3/8-24NF-2 | 2 | ea |
| 16-7 | H1 | 012-1224 | H101-0121224 | 121224 | PIN, COTTER, split, S, pltd, 3/32 x 1 (stabilizer link to stabilizer bar) | 2 | ea |
| | H1 | 013-7185 | H001-4417731 | 137185 | PIN, COTTER, split, S, cd- or zn-pltd, 1/8 x 1 | 2 | ea |
| 16-7 | H1 | 5310-013-1016 | H001-7043861 | 131016 | WASHER, FLAT, SAE, std, S, cd- or zn-pltd, 2 1/32 ID, 1 1/8 OD, 3/32 thk (stabilizer link to shaft) | 2 | ea |

| (1) ILLUSTRATION NO. | (2) REFER- ENCE SYMBOLS | (3) FEDERAL STOCK NO. | (4) ORDNANCE STOCK NO. | (5) MFR'S PART NO. | (6) ORDNANCE PART NO. | (7) DESCRIPTION | (8) QUANTITY INCOR- PORATED IN UNIT | (9) UNIT OF ISSUE |
|-------------------------|----------------------------------|-----------------------------|------------------------------|-----------------------|-----------------------------|--|---|----------------------------|
| | | | | | | GROUP 16—SPRINGS AND SHOCK ABSORBERS —Continued | | |
| | | | | | | 1605—STABILIZER BARS (M170)—Continued | | |
| 16-8 | | | G758-8333299 | WO-808717 | 8333299 | LINK, stabilizer (rear)..... | 2 | ea |
| 16-8 | H1 | 012-5348 | H101-0125348 | | 125348 | NUT, SLOTTED, HEXAGON, lt, thk, s-fin, S, cd- or zn-pltd, 3/8-24NF-2..... | 2 | ea |
| 16-8 | H1 | 012-1224 | H101-0121224 | | 121224 | PIN, COTTER, split, S, pltd, 3/32 x 1 (stabilizer link to stabilizer bar)..... | 2 | ea |
| | H1 | 013-7185 | H001-4417731 | | 137185 | PIN, COTTER, split, S, cd- or zn-pltd, 1/4 x 1 (stabili- zer link to shaft)..... | 2 | ea |
| 16-8 | H1 | 5310-013-1016 | H001-7043861 | | 131016 | WASHER, FLAT, SAE, std, S, cd- or zn-pltd, 2 1/32 ID, 1 5/16 OD, 3/32 thk (stabilizer link to shaft)..... | 2 | ea |
| 16-7, 8 | | | | WO-808713 | | PLATE, mounting bracket..... | 4 | ea |
| 16-7, 8 | | | G758-8333425 | WO-642944 | 8333425 | RETAINER, cushion..... | 8 | ea |
| | | | | | | GROUP 17—FENDERS AND HOOD | | |
| | | | | | | 1701—FENDERS AND APRONS | | |
| | | | | WO-680403 | 8393198 | ANTI-SQUEAK, 1 1/2 wide, 15.94 lg, 1/16 thk (fender to body side panel)..... | 2 | ea |
| | | | | WO-680001 | 8677609 | APRON, splash, left front fender..... | 1 | ea |
| | | | | WO-680002 | | APRON, splash, right front fender..... | 1 | ea |
| | | | | WO-680125 | | BRACE, fender, front (used on vehicles thru serial No. 60406)..... | 2 | ea |
| | | | | WO-684285 | | BRACE, fender, front (used on vehicles after serial No. 60406)..... | 2 | ea |
| | | | G758-8328417 | WO-680475 | 8328417 | BRACE, left fender, front, w/weld NUTS, assy (used on vehicles up to serial No. 60406)..... | 1 | ea |
| | | | | WO-684501 | | BRACE, left fender, front, w/weld NUTS (used on vehicles after serial No. 60406)..... | 1 | ea |
| | | | G758-8328418 | WO-680466 | 8328418 | BRACE, right fender, front, assy..... | 1 | ea |
| | H1 | | H101-9409115 | | 9409115 | BOLT, assembled, washer, hex-hd, split lock washer, S, cd- or zn-pltd, 3/8-24UNF-2A x 1 1/2..... | 4 | ea |
| | H1 | 5310-012-0388 | H001-7045591 | | 120388 | WASHER, flat, S, cd- or zn-pltd, 1/16 ID, 1 OD, 0.083 thk..... | 4 | ea |
| | | | | WO-677927 | | FENDER, front, left, w/NUTS and RETAINERS assy (superseded by FENDER WO-688231) (used on vehicles through serial No. 73455) (M38A1)..... | 1 | ea |

| | | | | | | | |
|------------|---------------|-------------------------|-----------|---|---|----|----|
| 18-1, 2, 3 | | G758-8328420 | WO-688231 | | FENDER, front, left, w/NUTS and RETAINERS, assy (supersedes FENDER WO-677927) (used on M38A1 after serial No. 73455 and at start on M170 production) | 1 | ea |
| | | | WO-680455 | 8328420 | FENDER, front, left, w/weld NUTS, assy (welded) (complete) (superseded by FENDER WO-684565) (used on vehicle through serial No. 60406) (M38A1) | 1 | ea |
| | | | WO-684565 | | FENDER, front, left, w/weld NUTS (welded) (complete) (supersedes FENDER 8328420) (superseded by FENDER WO-688233) (used on vehicles after serial No. 60406) (M38A1) | 1 | ea |
| | | | WO-688233 | | FENDER, front, left, w/weld NUTS, assy (welded) (complete) (supersedes FENDER WO-684565) (used on M38A1 after serial No. 73456 and at start on M170 production) | 1 | ea |
| | | | WO-677928 | | FENDER, front, right, w/NUTS and RETAINERS, assy (superseded by FENDER WO-688232) (used on vehicles through serial No. 73455) (M38A1) | 1 | ea |
| | | | WO-688232 | | FENDER, front, right, w/NUTS and RETAINERS, assy (used on M38A1 after serial No. 73455 and at start on M170 production (supersedes FENDER WO-677928) | 1 | ea |
| 18-1, 2, 3 | 5305-737-2886 | G758-8328421 | WO-680456 | 8328421 | FENDER, front, right, w/weld NUTS, assy (welded) (complete) (superseded by FENDER WO-684566) (used on vehicles through serial No. 60406) (M38A1) | 1 | ea |
| | | | WO-684566 | | FENDER, front, right, w/weld NUTS, assy (welded) (complete) (supersedes FENDER 8328421) (superseded by FENDER WO-688234) (M38A1) | 1 | ea |
| | | | WO-688234 | | FENDER, front, right, w/weld NUTS, assy (welded) (complete) (used on M38A1 after serial No. 73456 and at start on M170 production (supersedes FENDER WO-684566) | 1 | ea |
| | | | WO-673468 | 7372886 | SCREW, int-teeth lock washer, hex-hd, S, cd- or zn-pltd, $\frac{5}{16}$ -18NC x $\frac{3}{8}$ | 8 | ea |
| | | | WO-A2891 | 8393066 | FILLER, front fender brace (used on vehicles through serial No. 60406) | 2 | ea |
| | | ONB-SN2716 WO-680445 | | NUT, weld, S, $\frac{5}{16}$ -18NC (left front fender (6) right front fender (1) engines up to serial No. 29295 left front fender (4) right front fender (3) (used on engines after serial No. 29295) | 14 | ea | |
| | | ONB-SN1610 WO-674898 | 8677317 | NUT, weld, S, No. 10-24NC (left front fender)..... | 1 | ea | |
| | | WO-663858 | | NUT, weld, S, $\frac{1}{4}$ -20NC (left front fender brace)..... | 2 | ea | |
| | | ONB-SN2113 WO-674350 | | NUT, weld, S, $\frac{1}{4}$ -20NC (left front fender (2), right front fender (2)) | 4 | ea | |
| | | WO-682169 | | REINFORCEMENT, front fender rear corner, left and right | 2 | ea | |

1701

25

| (1) ILLUSTRATION NO. | (2) REFERENCE SYMBOLS | (3) FEDERAL STOCK NO. | (4) ORDNANCE STOCK NO. | (5) MFR'S PART NO. | (6) ORDNANCE PART NO. | (7) DESCRIPTION | (8) QUANTITY IN- CORPORATED IN UNIT | (9) UNIT OF ISSUE |
|-------------------------|--------------------------|--------------------------|---------------------------|-----------------------|--------------------------|--|--|-------------------------|
| | | | | | | GROUP 17—FENDERS AND HOOD—Continued | | |
| | | | | | | 1701—FENDERS AND APRONS—Continued | | |
| | | | | WO-A3098 | | REINFORCEMENT, front fender brace, left and right (used on vehicles through serial No. 60406) | 2 | ea |
| | | | | WO-683517 | | REINFORCEMENT (front fender brace, left) | 1 | ea |
| | | | | WO-683518 | | REINFORCEMENT, front fender brace, right (used on vehicles after serial No. 60406) | 1 | ea |
| | | 2510-769-7548 | G740-7697548 | WO-A3549 | 7697548 | RETAINER, sq-nut, 5/16 in. (right front fender to radiator guards (2) left front fender radiator guards (2)) | 4 | ea |
| | H1 | 012-0399 | H001-4139781 | | 120399 | NUT, mach screw, sq, S, cd- or zn-pltd, 5/16-18NC-2 | 4 | ea |
| | | | | | | 1703—HOOD | | |
| | | | G758-8328461 | WO-680577 | 8328461 | BOLT, "U", hood catch, S, cd- or zn-pltd, 1/4-20NC | 1 | ea |
| | H1 | | H101-0271172 | | 271172 | NUT, hex, ext-teeth lock washer, S, cd- or zn-pltd, 1/4-20NC-2B | 2 | ea |
| | | 2510-769-7483 | G740-7697483 | WO-673436 | 7697483 | BRACKET, catch | 2 | ea |
| | H1 | | H101-0191985 | | 191985 | SCREW, ext-teeth-lock washer, cross-recess-pan-hd, S, cd- or zn-pltd, 1/4-20NC-2 x 1/2 | 4 | ea |
| | | | | WO-681233 | 8677400 | BRACKET, support, shovel blade retainer | 1 | ea |
| | | | | WO-681263 | 8393226 | BRACKET, support, shovel blade retainer (panel reinforcement) | 1 | ea |
| | | 2510-769-7487 | G740-7697487 | WO-673631 | 7697487 | CATCH | 2 | ea |
| | H1 | | H101-9409106 | | 9409106 | BOLT, machine, assembled washer, hex-hd, split lock washer, S, cd- or zn-pltd, 1/4-20UNC 2 x 1/2 | 4 | ea |
| | | | G758-8328469 | WO-680664 | 8328469 | COVER, breather tube opening (panel, right side) | 1 | ea |
| | H1 | | H101-0454783 | | 454783 | SCREW, assembled washer, cross-recess-pan-hd, int-teeth-lock washer, header-pt, S, cd- or zn-pltd, No. 10, (0.190)-24NC-2A x 1/2 | 2 | ea |
| | | | G758-8328470 | WO-680935 | 8328470 | HINGE, left, w/PIN, assy (half) | 1 | ea |
| | | | G758-8328471 | WO-680936 | 8328471 | HINGE, right, w/PIN, assy (half) | 1 | ea |
| | | | G740-7697440 | WO-673597 | 7697440 | SCREW, assembled washer, hex-hd, int-teeth lock washer, header-pt, S, cd- or zn-pltd, 5/16-18UNC-2A x 3/4 (superseded by SCREW 425388) | 6 | ea |
| | H1 | | H101-0425388 | | 425388 | SCREW, int-teeth-lock washer, hex-hd, header-pt, S, cd- or zn-pltd, 5/16-18NC-2 x 5/8 (supersedes SCREW 7697440) | 6 | ea |
| | | | | WO-680457 | 8677598 | HOOD, w/weld NUTS, assy (welded) (complete) | 1 | ea |
| 18-1 | | | G758-8328472 | WO-680475 | 8328472 | HOOD, assy (painted) | 1 | ea |

| | | | | | | |
|----|----------|--------------------------|---------|--|---|----|
| H2 | | H002-7697591 | 7697591 | LOOP, footman (windshield hold-down, panel)..... | 1 | ea |
| H1 | 015-5937 | H101-0155937 | 155937 | BOLT, machine, cross-recess fl-hd, S, cd- or zn-pltd, No. 10 (0.190)-24NC-2 x 1/2 | 2 | ea |
| | | | 8676969 | NUT, weld, S, 1/4-20NC (panel)..... | 4 | ea |
| | | ONB-SN2113 WO-674350 | 8677317 | NUT, weld, S, No. 10-24NC (panel (2), reinforcement (2)) | 4 | ea |
| | | ONB-SN-1610 WO-674898 | | NUT, weld, S, 5/16-18NC (panel reinforcement, rear)..... | 6 | ea |
| | | ONB-SN-2716 WO-680445 | | REINFORCEMENT, panel, front..... | 1 | ea |
| | | WO-680270 | | REINFORCEMENT, w/weld NUTS, assy (footman loop) | 1 | ea |
| | | WO-680994 | 8393205 | REINFORCEMENT, w/weld NUTS, assy (panel, rear)..... | 1 | ea |
| | | WO-680293 | | | | |

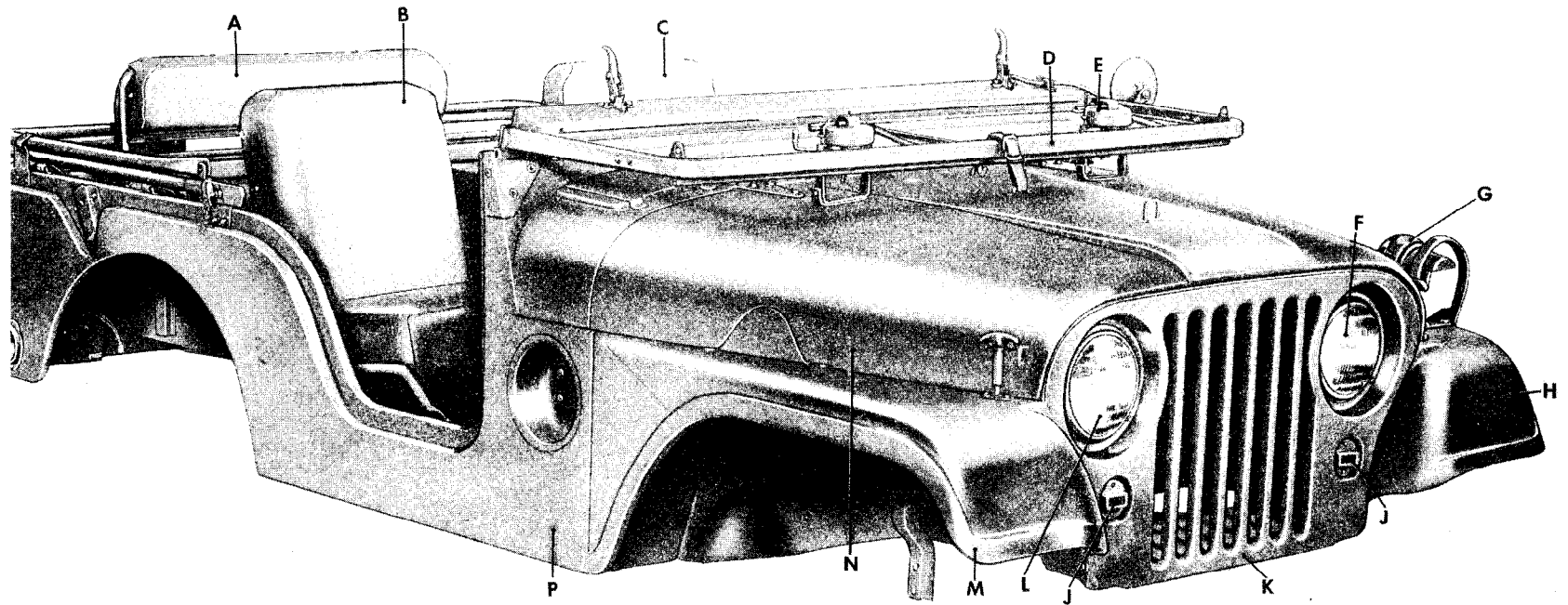

| KEY ITEM | PART NO | GROUP | KEY ITEM | PART NO | GROUP |
|--------------------|---------|--------|---------------|-----------|--------|
| A—SEAT, ASSY | 7697535 | 1806 | H—FENDER | WO-688233 | 1701 |
| B—SEAT, ASSY | 7697534 | 1806 | J—LIGHT, ASSY | 7723899 | 0609.1 |
| C—SEAT, ASSY | 8328489 | 1806 | K—GUARD, ASSY | WO-684569 | 2101 |
| D—WINDSHIELD, ASSY | 8332065 | 1804 | L—LIGHT, ASSY | 7760504 | 0609.1 |
| E—MOTOR, ASSY | 500844 | 2202 | M—FENDER | WO-688234 | 1701 |
| F—LIGHT, ASSY | 8673513 | 0609.1 | N—HOOD | 8328472 | 1703 |
| G—LIGHT, ASSY | 7760505 | 0609.1 | P—BODY, ASSY | WO-680637 | 1800 |

RA PD 367182

Figure 18-1. Body—right front view

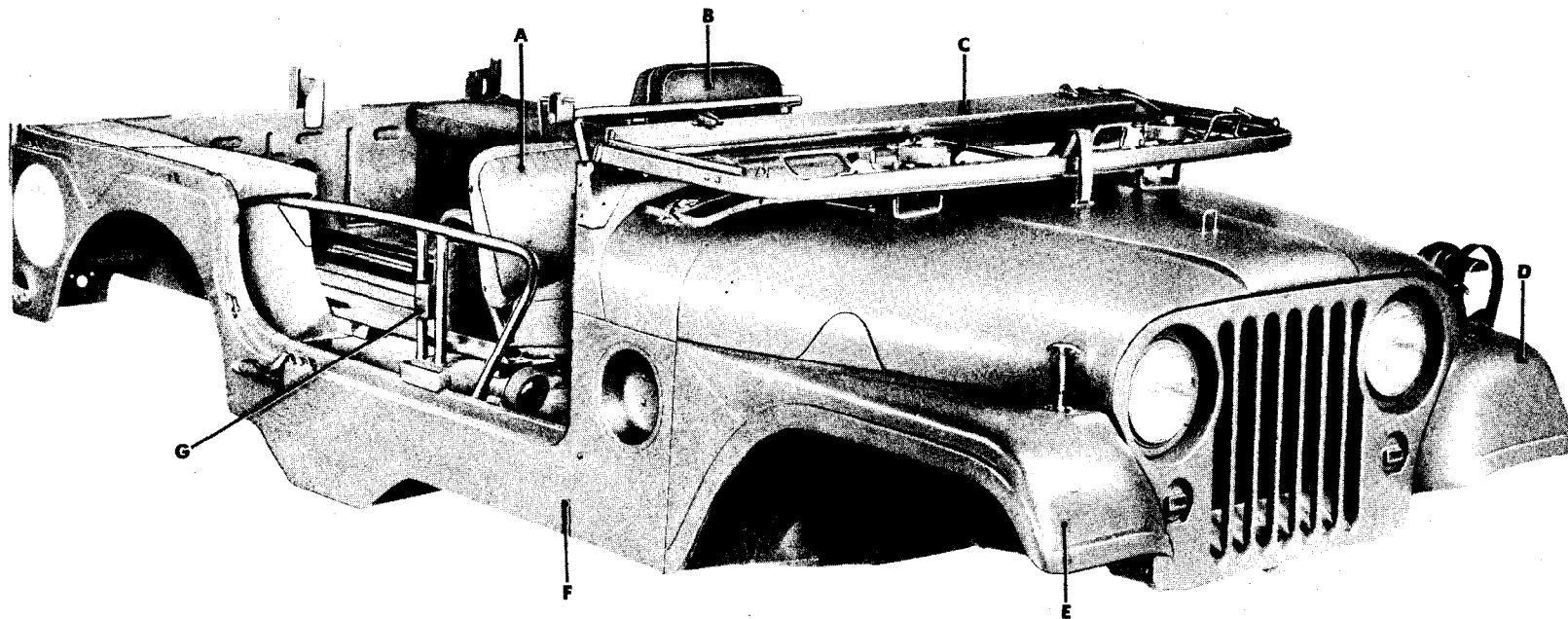

| KEY ITEM | PART NO | GROUP | KEY ITEM | PART NO | GROUP |
|--------------|-----------|-------|-----------|-----------|-------|
| A—CUSHION | WO-691552 | 1806 | E—FENDER | WO-688234 | 1701 |
| B—SEAT | WO-691551 | 1806 | F—BODY | WO-685901 | 1800 |
| C—WINDSHIELD | WO-683937 | 1804 | G—SUPPORT | WO-685380 | 1504 |
| D—FENDER | WO-688233 | 1701 | | | |

RA PD 367184

Figure 18-2. Body—right front view w/spare wheel carrier (M170)

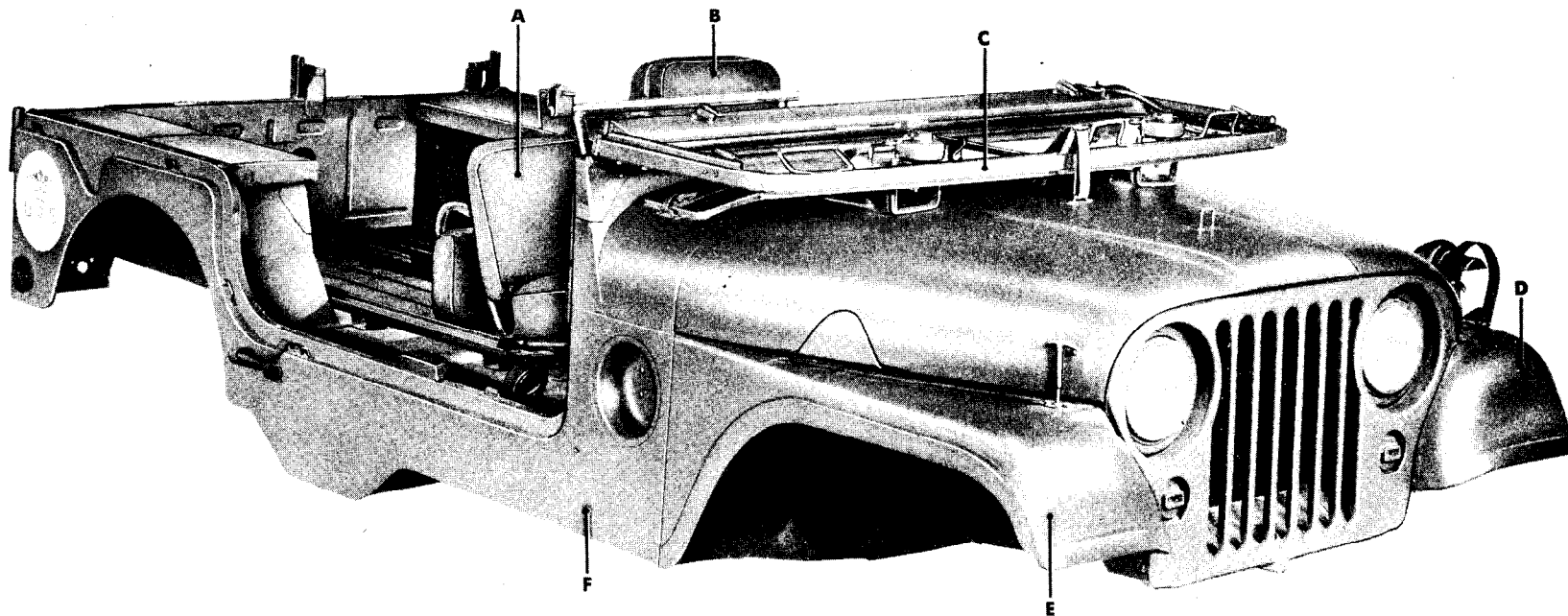

| KEY ITEM | PART NO | GROUP | KEY ITEM | PART NO | GROUP |
|--------------|-----------|-------|----------|-----------|-------|
| A—CUSHION | WO-691552 | 1806 | D—FENDER | WO-688233 | 1701 |
| B—SEAT | WO-691551 | 1806 | E—FENDER | WO-688234 | 1701 |
| C—WINDSHIELD | WO-683937 | 1804 | F—BODY | WO-685901 | 1800 |

RA PD 367168

Figure 18-3. Body—right front view w/o spare wheel carrier (M170)

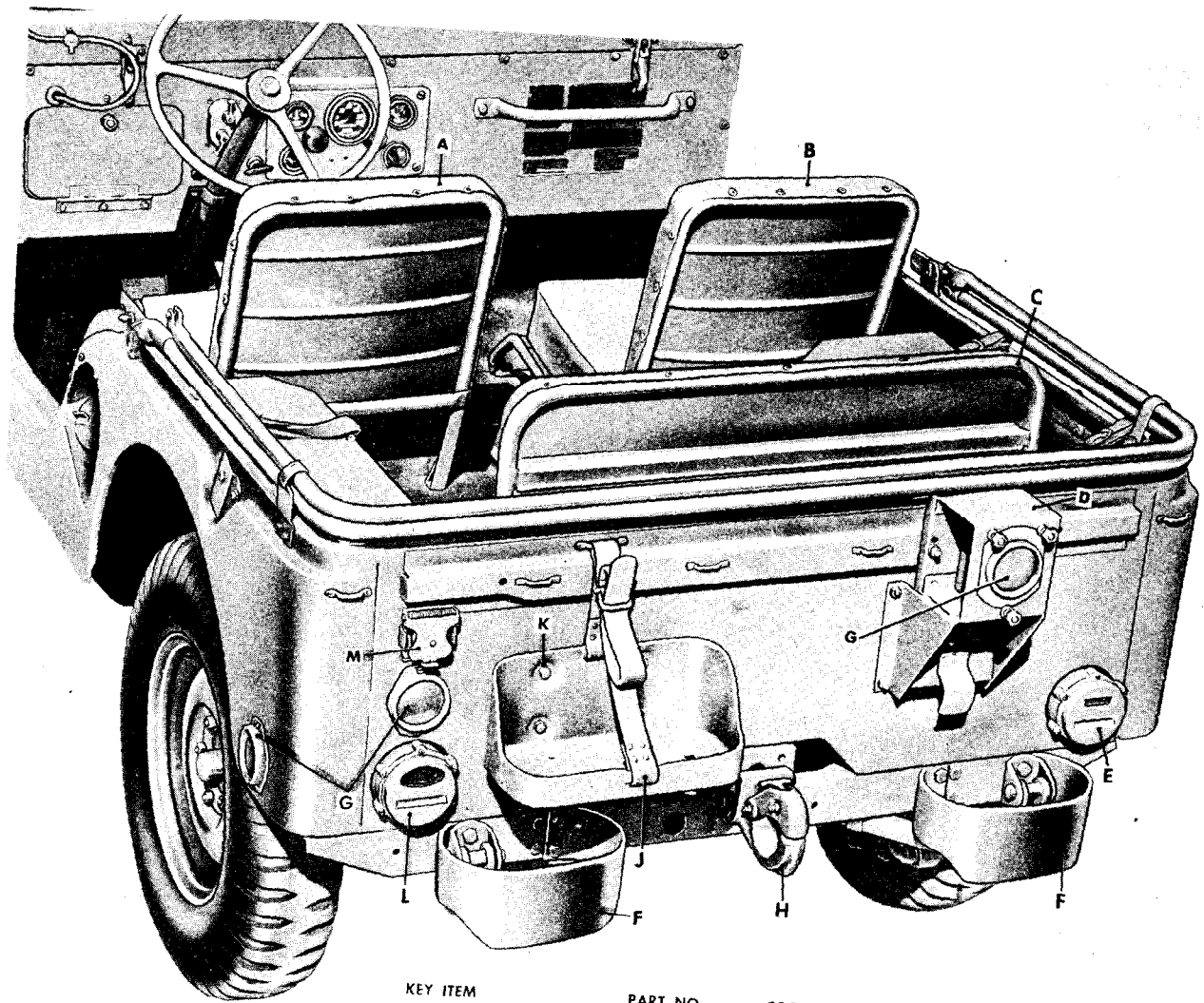

| KEY ITEM | PART NO | GROUP |
|-----------------|-----------|--------|
| A—SEAT, ASSY | 8328489 | 1806 |
| B—SEAT, ASSY | 7697534 | 1806 |
| C—SEAT, ASSY | 7697535 | 1806 |
| D—BRACKET, ASSY | WO-689016 | 1504 |
| E—LIGHT, ASSY | 7760506 | 0609.1 |
| F—BUMPERETTE | 7372819 | 2101 |
| G—REFLECTOR | 506101 | 2202 |
| H—PINTLE, ASSY | 7073209 | 1503 |
| J—STRAP, ASSY | 7698489 | 1808 |
| K—BRACKET, ASSY | 7375163 | 1808 |
| L—LIGHT, ASSY | 7760507 | 0609.1 |
| M—COVER, ASSY | 7731428 | 0617 |

RA PD 367248

Figure 18-4. Body—rear view

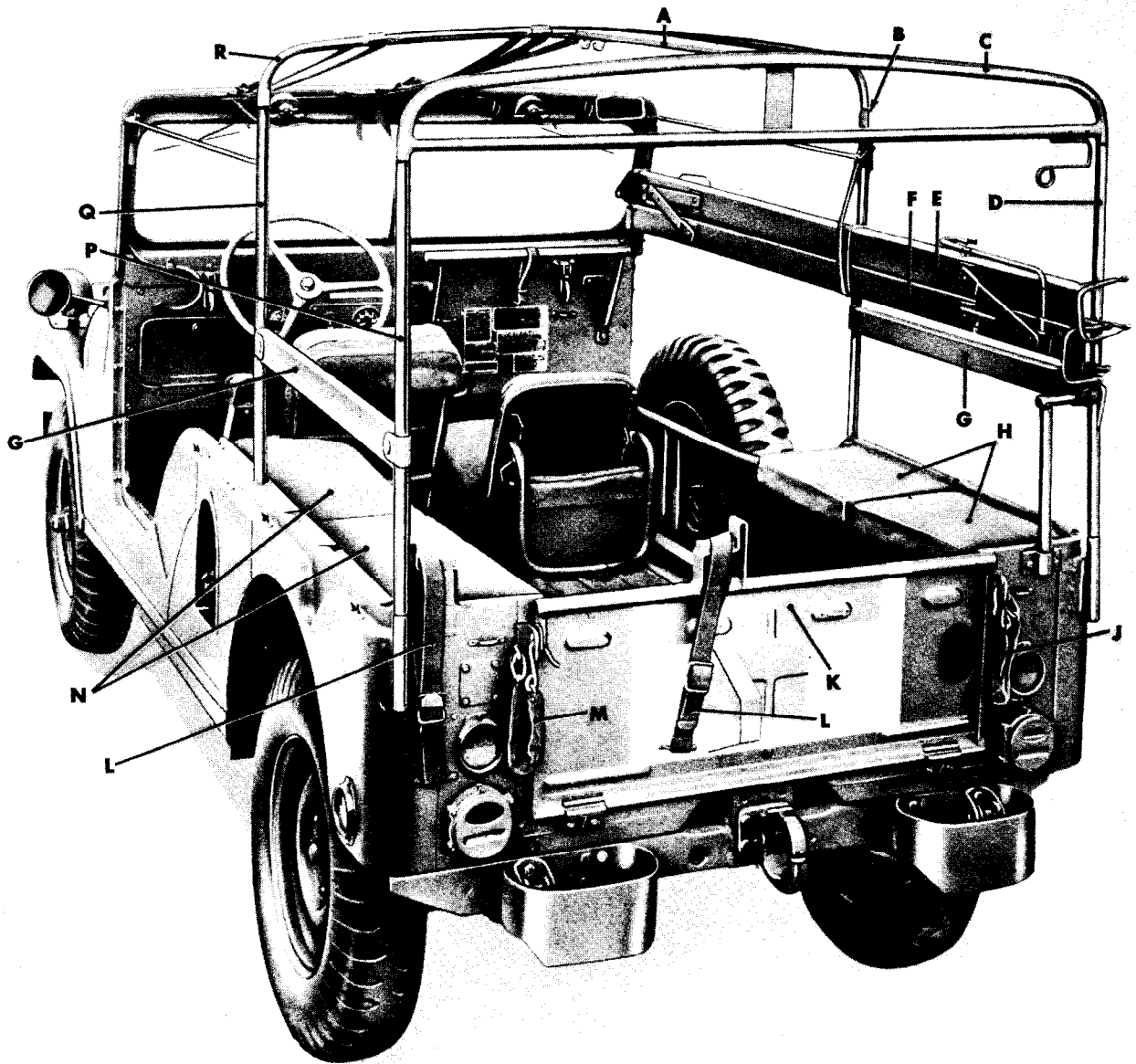

| KEY | ITEM | PART NO | GROUP | KEY | ITEM | PART NO | GROUP |
|-----|---------|-----------|-------|-----|-----------------|-----------|--------|
| A | BOW | WO-683000 | 2201 | J | HOOK, ASSY | WO-684130 | 1803.1 |
| B | BOW | WO-683024 | 2201 | K | TAIL GATE, ASSY | WO-684072 | 1803.1 |
| C | BOW | WO-684988 | 2201 | L | STRAP | WO-685789 | 1808 |
| D | BOW | WO-685000 | 2201 | M | HOOK, ASSY | WO-684129 | 1803.1 |
| E | RACK | WO-684972 | 1812 | N | CUSHION | WO-691543 | 1812 |
| F | RACK | WO-684964 | 1812 | P | BOW | WO-683003 | 2201 |
| G | REST | WO-683013 | 1812 | Q | BOW | WO-683023 | 2201 |
| H | CUSHION | WO-691544 | 1812 | R | BOW | WO-684996 | 2201 |

RA PD 367185

Figure 18-5. Body—rear view (M170)

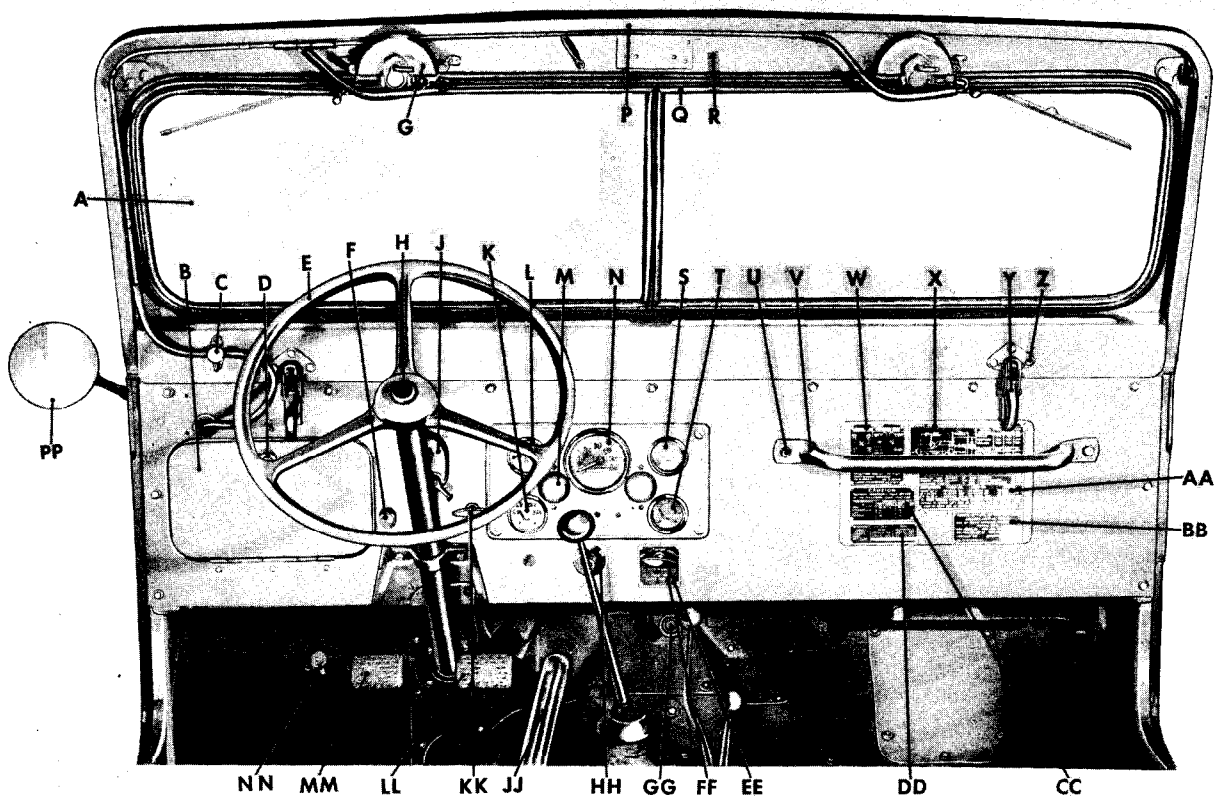

| KEY | ITEM | PART NO | GROUP | KEY | ITEM | PART NO | GROUP |
|-----|---------------------|----------|--------|-----|---------------|---------|--------|
| A | GLASS | 59-G-673 | 1804 | W | PLATE | 8386440 | 2210 |
| B | DOOR | 8329650 | 1808 | X | PLATE | 8386439 | 2210 |
| C | VALVE | 8329996 | 2202 | Y | LOCK, ASSY | 8329653 | 1804 |
| D | LOCK, ASSY | 7375399 | 1808 | Z | BOLT AND L/W | 9409107 | 1804 |
| E | WHEEL, ASSY | 7375336 | 1401 | AA | PLATE | 8673359 | 2210 |
| F | CONTROL, ASSY | 8329760 | 0312 | BB | PLATE | 8677436 | 2210 |
| G | MOTOR, ASSY | 500844 | 2202 | CC | PLATE | 7697562 | 2210 |
| H | CAP | 7412442 | 0611 | DD | PLATE | 7697561 | 2210 |
| J | SWITCH, ASSY | 7368702 | 0607 | EE | CONTROL | 8329636 | 0304.5 |
| K | GAGE, ASSY | 8376379 | 0607 | FF | PLATE | 7697554 | 2210 |
| L | AMMETER, ASSY | 8376378 | 0607 | GG | PEDAL | 7760417 | 0603 |
| M | LIGHT, ASSY | 7760412 | 0607 | HH | SWITCH, ASSY | 7760409 | 0607 |
| N | SPEEDOMETER, ASSY | 8376375 | 2208.1 | JJ | PEDAL, ASSY | 8333364 | 0312 |
| P | FRAME, ASSY | 8329652 | 1804 | KK | CONTROL, ASSY | 8329761 | 0312 |
| Q | WEATHERSEAL | 8329659 | 1804 | LL | PEDAL, ASSY | 7697453 | 1206 |
| R | WINDSHIELD, ASSY | 8332065 | 1804 | MM | PEDAL, ASSY | 7371342 | 0202 |
| S | GAGE, ASSY | 8376374 | 0607 | NN | SWITCH, ASSY | 7728788 | 0608 |
| T | GAGE, ASSY | 8376380 | 0607 | PP | MIRROR, ASSY | 547202 | 2202 |
| U | SCREW AND L/W, ASSY | 451976 | 2101 | | | | |
| V | RAIL | 8677566 | 2101 | | | | |

RA PD 367244

Figure 18-6. Front compartment

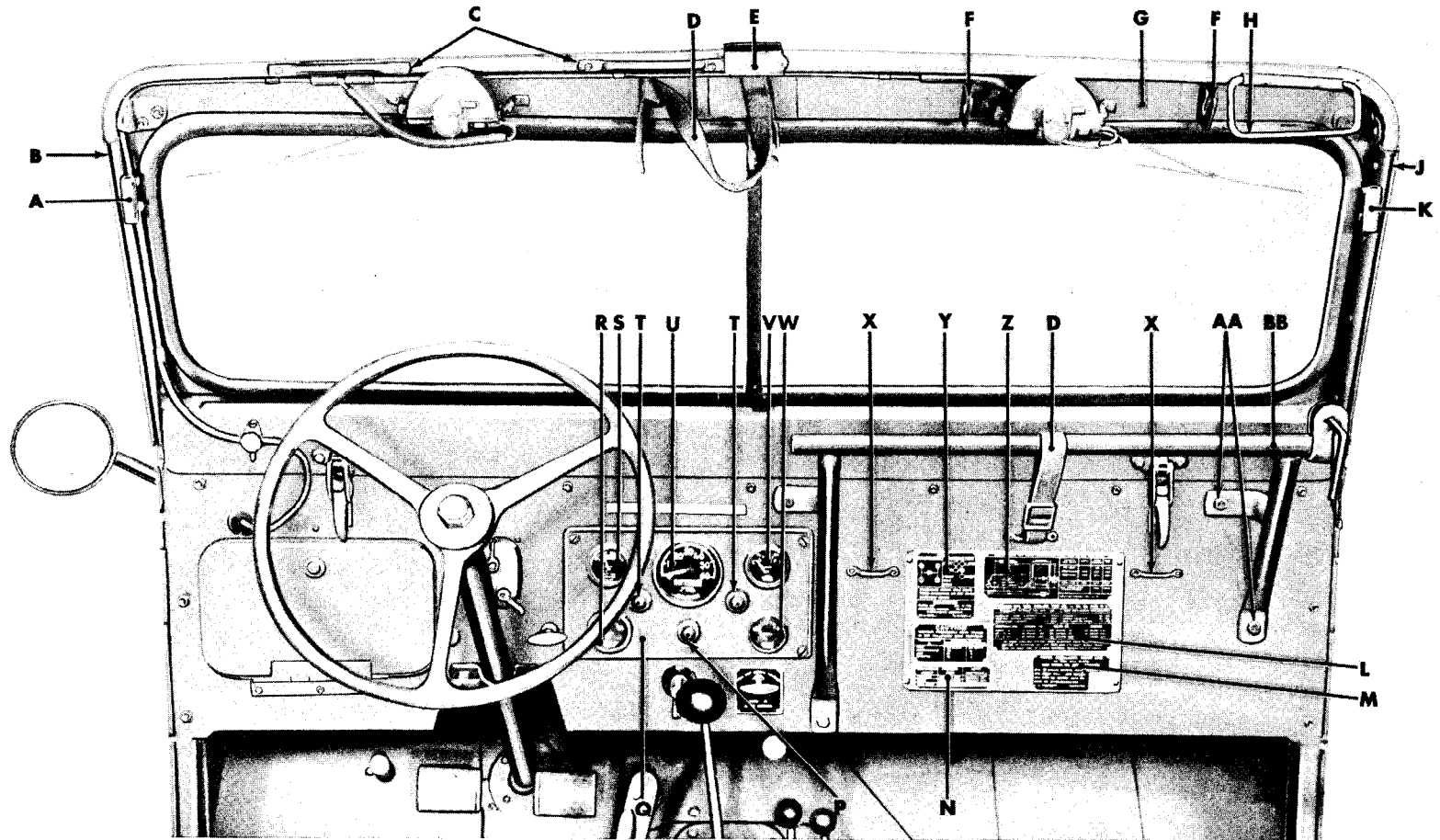

| KEY ITEM | PART NO | GROUP | KEY ITEM | PART NO | GROUP | KEY ITEM | PART NO | GROUP |
|--------------|-----------|-------|-----------|-----------|-------|---------------|-----------|--------|
| A—BRACKET | WO-680751 | 1804 | K—BRACKET | WO-680752 | 1804 | U—SPEEDOMETER | 8376375 | 2208.1 |
| B—RETAINER | 8677552 | 1804 | L—PLATE | 8333427 | 2210 | V—GAGE | 8376374 | 0607 |
| C—LOOP | WO-685721 | 1804 | M—PLATE | 8333426 | 2210 | W—GAGE | 7954230 | 0607 |
| D—STRAP | 8329988 | 1808 | N—PLATE | 7697561 | 2210 | X—LOOP | 7697591 | 1804 |
| E—BRACKET | WO-685456 | 1804 | P—LIGHT | 7358619 | 0607 | Y—PLATE | 8333429 | 2210 |
| F—BRACKET | WO-685468 | 1804 | Q—PLATE | AL-26809 | 0607 | Z—PLATE | 8333428 | 2210 |
| G—WINDSHIELD | WO-683937 | 1804 | R—GAGE | 7954511 | 0607 | AA—SCREW | 451977 | 1808 |
| H—BRACKET | WO-685739 | 1804 | S—GAGE | 8376377 | 0607 | BB—SUPPORT | WO-685299 | 1808 |
| J—RETAINER | WO-680372 | 1804 | T—LIGHT | 7358618 | 0607 | | | |

RA PD 367151

Figure 18-7. Front compartment (M170)

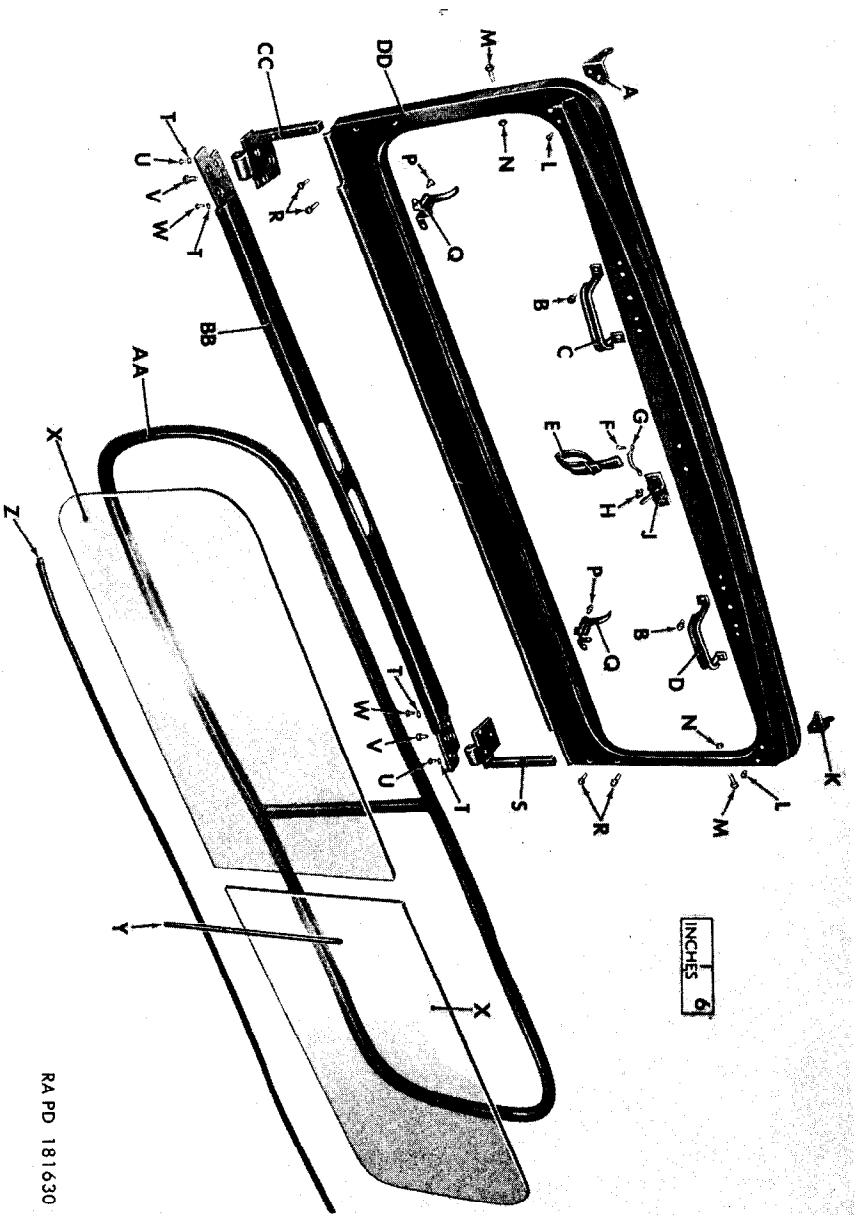

RA PD 181630

Figure 18-8. Windshield and related parts—exploded view

| <i>Key</i> | <i>Item</i> | <i>Part No.</i> | <i>Group</i> |
|------------|-----------------------|-----------------|--------------|
| A | -BRACKET | WO-680822 | 1804 |
| B | -BOLT, w/LOCK WASHER | 425379 | 1804 |
| C | -BUMPER, ASSY | 8328465 | 1804 |
| D | -BUMPER, ASSY | 8328464 | 1804 |
| E | -STRAP, ASSY | 8329655 | 1808 |
| F | -SCREW | 162688 | 1804 |
| G | -LOOP | 7697591 | 1804 |
| H | -SCREW, w/LOCK WASHER | 425380 | 1804 |
| J | -CATCH, ASSY | 8328468 | 1804 |
| K | -BRACKET | 8393203 | 1804 |
| L | -SCREW, w/LOCK WASHER | 454783 | 1804 |
| M | -SCREW, w/LOCK WASHER | 425384 | 1804 |
| N | -NUT | 120375 | 1804 |
| P | -BOLT, w/LOCK WASHER | 9409107 | 1804 |
| Q | -LOCK, ASSY | 8329653 | 1804 |
| R | -BOLT, w/LOCK WASHER | 425338 | 1804 |
| S | -HINGE | 8677403 | 1804 |
| T | -WASHER | 120391 | 1804 |
| U | -BOLT | 159582 | 1804 |
| V | -SCREW, w/LOCK WASHER | 443775 | 1804 |
| W | -SCREW | 161860 | 1804 |
| X | -GLASS | 59-G-673 | 1804 |
| Y | -FILLER | IND-33197R | 1804 |
| Z | -FILLER | 8329651 | 1804 |
| AA | -WEATHERSEAL | 8329659 | 1804 |
| BB | -WEATHERSEAL | 8329658 | 1804 |
| CC | -HINGE | 8392985 | 1804 |
| DD | -FRAME, ASSY | 8329652 | 1804 |

Figure 18-8. Windshield and related parts—exploded view—legend

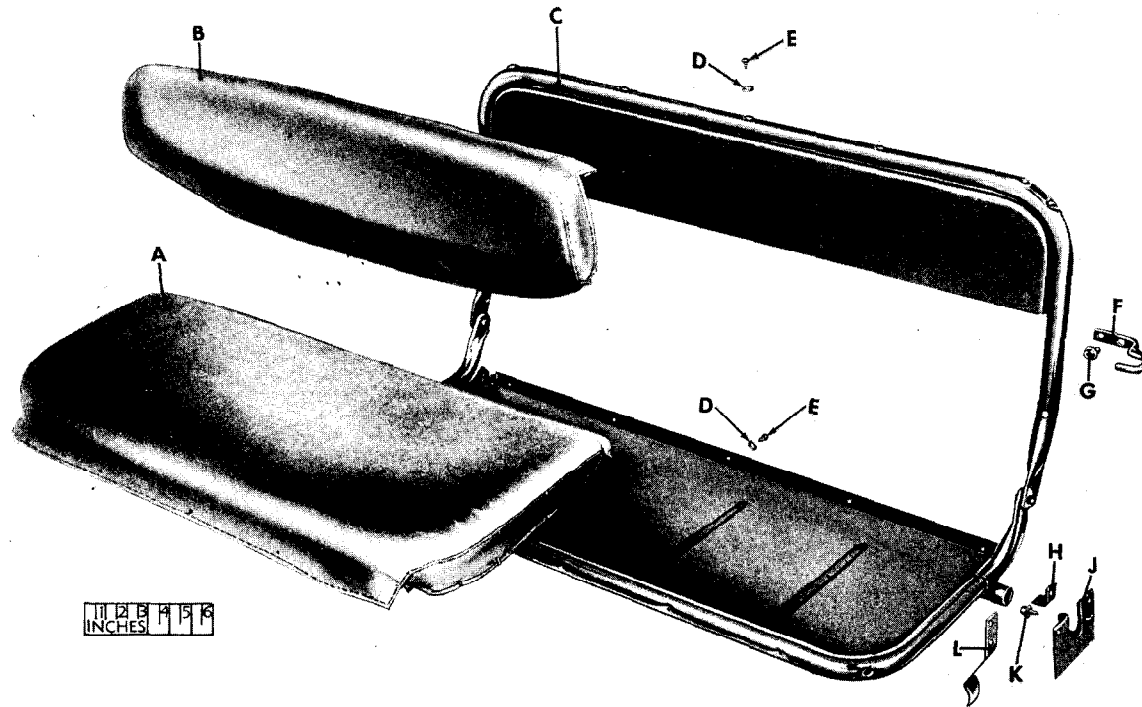

| KEY ITEM | PART NO. | GROUP | KEY ITEM | PART NO. | GROUP |
|-----------------|-----------|-------|-----------------------|----------|--------------|
| A—CUSHION, ASSY | 7697499 | 1806 | D—WASHER | 140241 | 1806 |
| B—CUSHION, ASSY | N.P.N. | 1806 | E—SCREW | 111687 | 1806 |
| CONSISTS OF: | | | F—BRACKET | 8328486 | 1806 |
| TRIM, ASSY | WO-673581 | 1806 | G—SCREW, W/LOCKWASHER | 425380 | 1806 |
| SPRING, ASSY | 7697538 | 1806 | H—RETAINER | 7697510 | 1806 |
| WASHER | 140241 | 1806 | J—BRACKET | 7697497 | 1804 |
| SCREW | 111687 | 1806 | K—BOLT, W/LOCKWASHER | 425379 | 1804 1806 |
| C—FRAME, ASSY | 8673489 | 1806 | L—RETAINER | 7697509 | 1806 |

NOTE: ITEMS F, G, H, J, K AND L ARE NOT PART OF ASSY 7697535

RA PD 367238

Figure 18-9. Seat, rear, assy

| KEY | ITEM | PART NO |
|-----|-------------------------------|-----------|
| A | CUSHION, ASSY | 7375008 |
| B | GROMMET, W/WASHER | 549189 |
| C | CUSHION, ASSY CONSISTS OF: | N.P.N. |
| | TRIM, ASSY | WO-672012 |
| | PAD | WO-671963 |
| | SPRING, ASSY | 7697537 |
| | CLIP | 7697531 |
| | WASHER | 140241 |
| | SCREW | 111687 |

11 12 14 19 19
INCHES

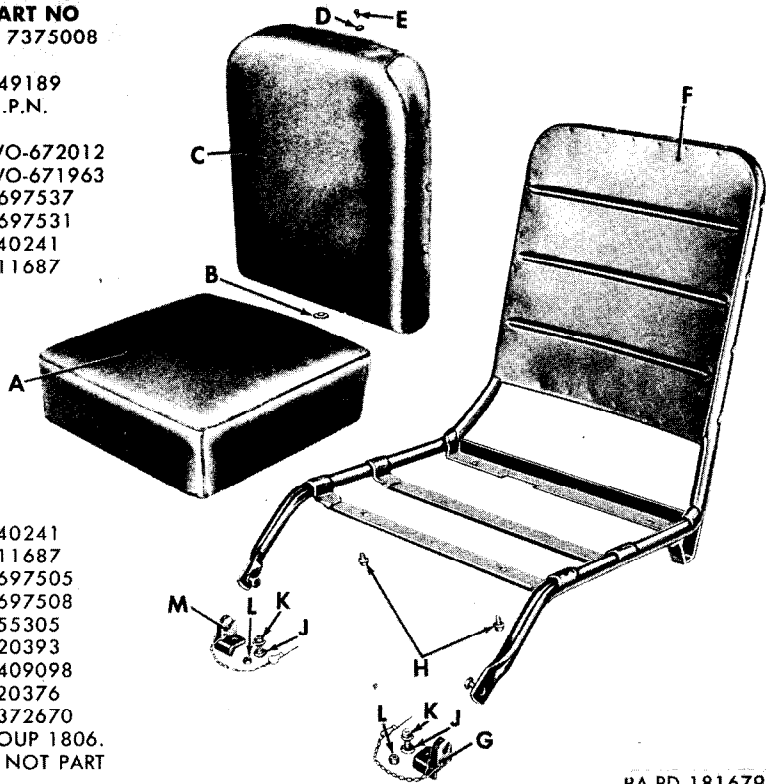

| | | |
|---|----------------|---------|
| D | WASHER | 140241 |
| E | SCREW | 111687 |
| F | FRAME, ASSY | 7697505 |
| G | PIVOT, ASSY | 7697508 |
| H | BOLT, W/WASHER | 455305 |
| J | WASHER | 120393 |
| K | BOLT, W/WASHER | 9409098 |
| L | NUT | 120376 |
| M | PIVOT, ASSY | 7372670 |

NOTE: ALL ITEMS ARE IN GROUP 1806.
ITEMS G, J, K, L AND M ARE NOT PART OF ASSEMBLY.

RA PD 181679

Figure 18-10. Seat, front, passenger, assy (7697534)

| KEY | ITEM | PART NO |
|-----|-------------------------------|-----------|
| A | CUSHION, ASSY | 7375008 |
| B | GROMMET, W/WASHER | 549189 |
| C | CUSHION, ASSY CONSISTS OF: | N.P.N. |
| | TRIM, ASSY | WO-672012 |
| | PAD | WO-671963 |
| | SPRING, ASSY | 7697537 |
| | CLIP | 7697531 |
| | WASHER | 140241 |
| | SCREW | 111687 |

11 12 14 19 19
INCHES

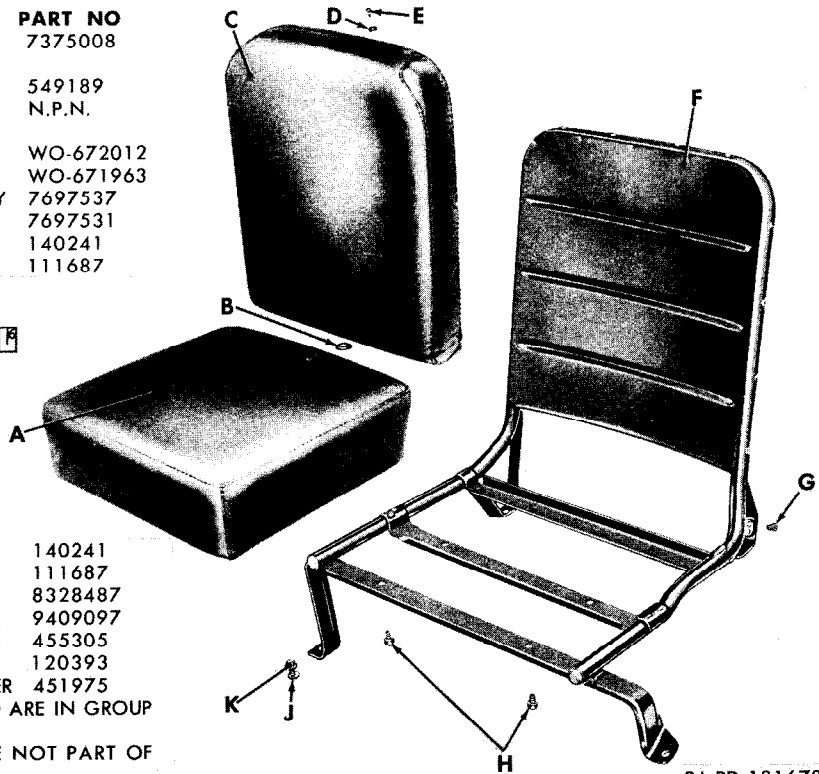

| | | |
|---|-----------------|---------|
| D | WASHER | 140241 |
| E | SCREW | 111687 |
| F | FRAME, ASSY | 8328487 |
| G | BOLT, W/WASHER | 9409097 |
| H | BOLT, W/WASHER | 455305 |
| J | WASHER | 120393 |
| K | SCREW, W/WASHER | 451975 |

NOTE: ALL PARTS LISTED ARE IN GROUP 1806.
ITEMS G, J AND K ARE NOT PART OF ASSEMBLY.

RA PD 181678

Figure 18-11. Seat, driver's, assy (8328489)

KEY ITEM

- A—BACK, ASSY
- B—WASHER
- C—SCREW
- D—FRAME
- E—PAD, ASSY
- F—SCREW W/LOCK WASHER
- G—WASHER
- H—SCREW
- J—FRAME

PART NO

- WO-691553
- 140241
- 111687
- WO-685154
- WO-691545
- 451975
- 446363
- 162487
- WO-685158

KEY ITEM

- K—PIVOT
- L—NUT W/LOCK WASHER
- M—SCREW
- N—STRAP
- P—SCREW
- Q—LOOP
- R—CUSHION

PART NO

- 7697506
- 271187
- 120213
- WO-685789
- 162457
- 7697591
- WO-691549

NOTE: ALL PARTS LISTED ARE IN GROUP 1806
ITEMS F, G, K, L AND M ARE NOT PART OF
ASSEMBLY

310

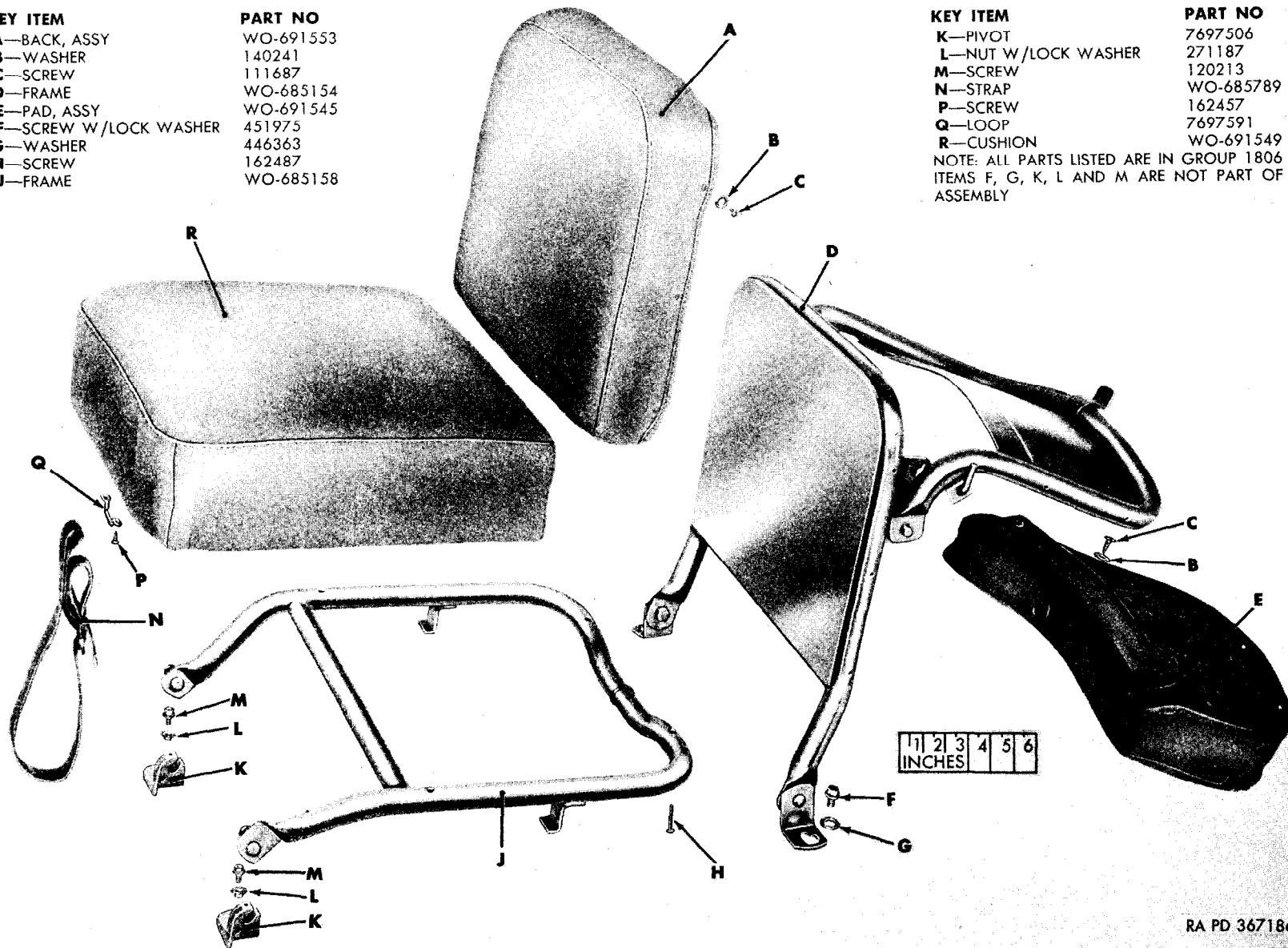

RA PD 367186

Figure 18-12. Seat, front, passenger, assy (7697534) and related parts (M170)

KEY ITEM
A—BACK, SEAT, ASSY
 CONSISTS OF:

PAD
 PAD
 RING
 SPRING
 TRIM

B—SCREW
C—WASHER
D—PAD W/COVER

PART NO
 WO-691550

WO-691537
 WO-691540
 WO-K300159
 WO-685521
 WO-685507

111687
 140241
 WO-691547

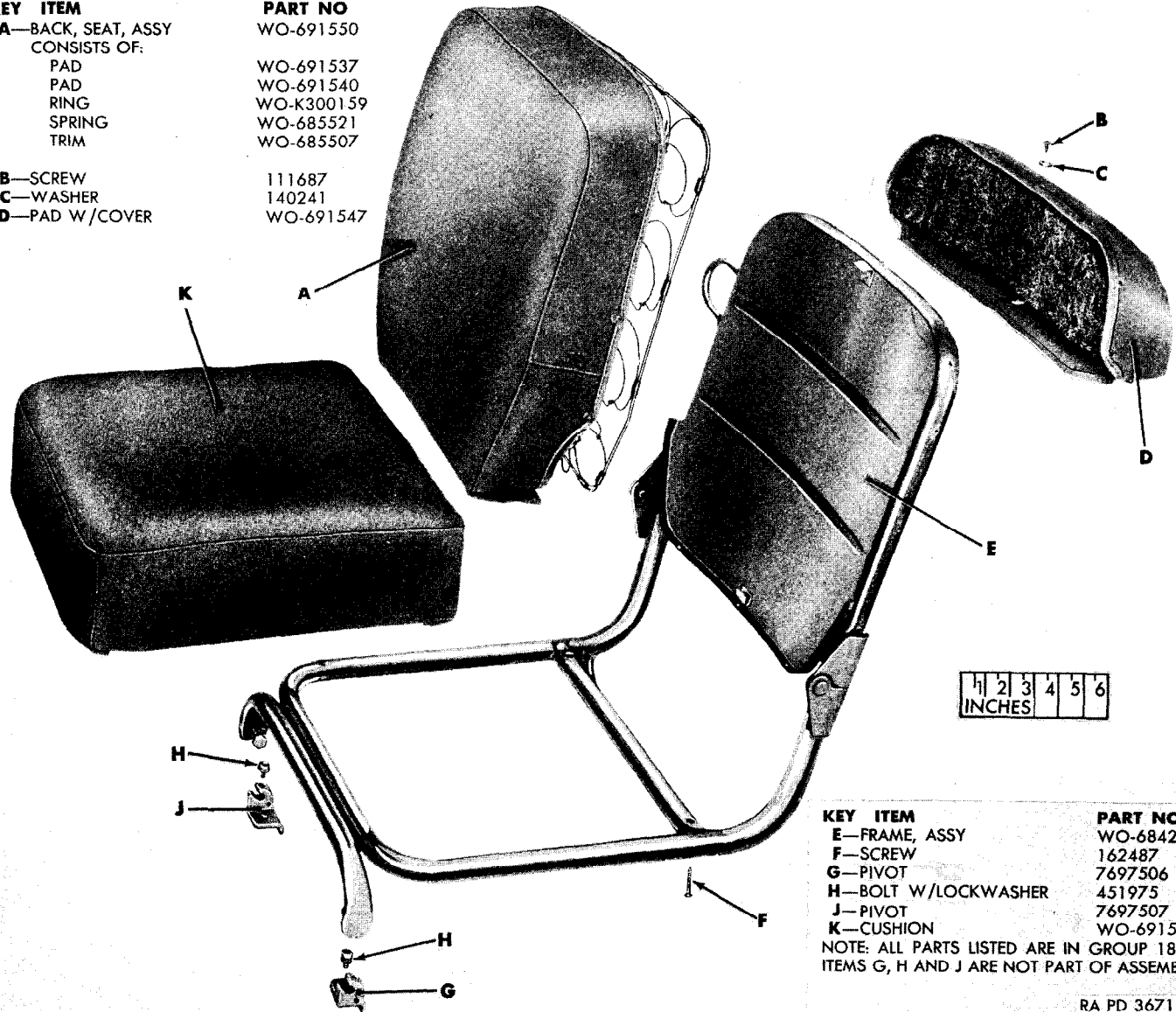

KEY ITEM

E—FRAME, ASSY
F—SCREW
G—PIVOT
H—BOLT W/LOCKWASHER
J—PIVOT
K—CUSHION

PART NO

WO-684250
 162487
 7697506
 451975
 7697507
 WO-691549

NOTE: ALL PARTS LISTED ARE IN GROUP 1806
 ITEMS G, H AND J ARE NOT PART OF ASSEMBLY

RA PD 367187

Figure 18-13. Seat, driver's, assy (8328489) (M170)

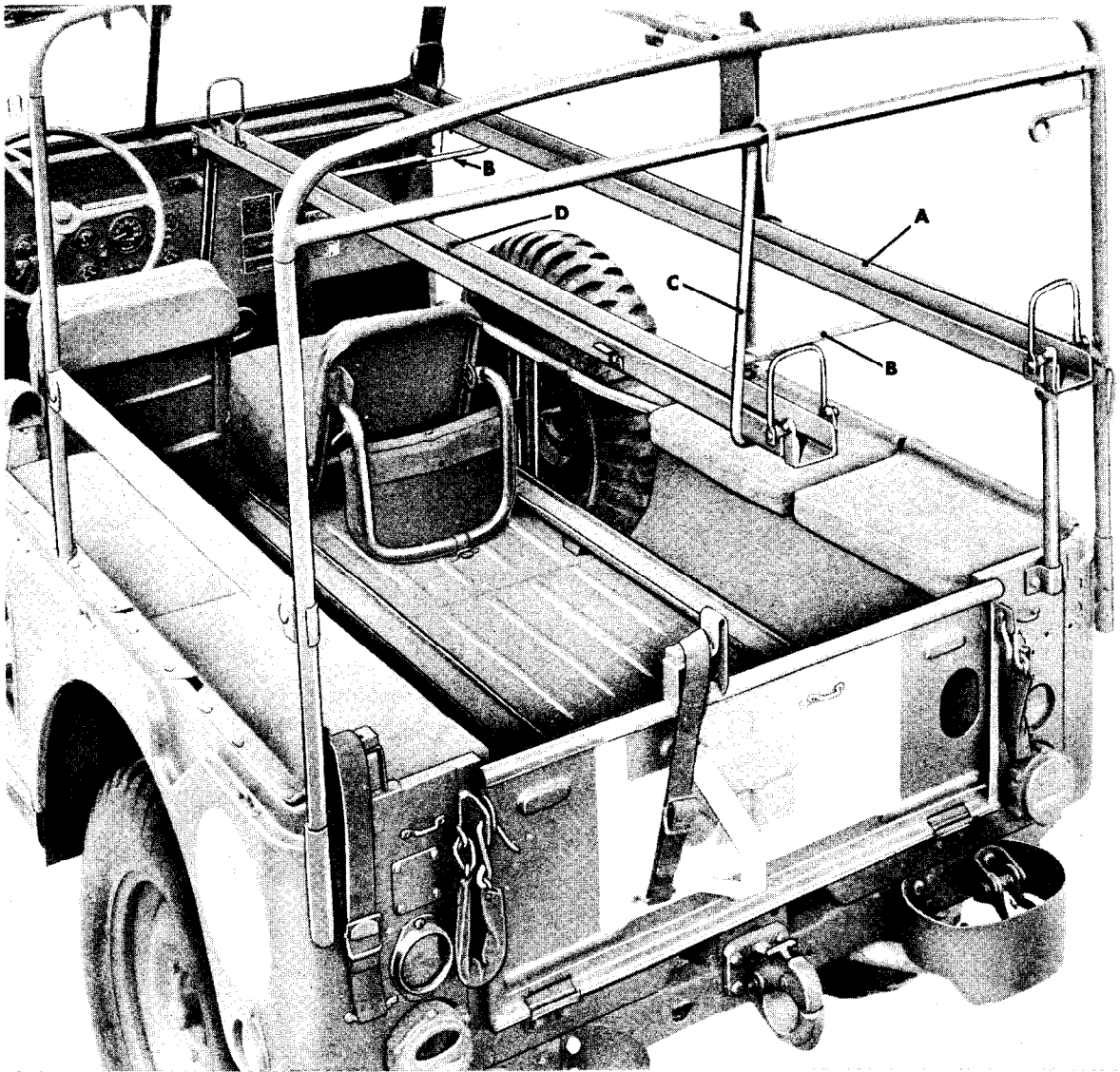

| KEY | ITEM | PART NO | KEY | ITEM | PART NO |
|-----|-------------|-----------|-----|-------------|-----------|
| A | RACK, OUTER | WO-684964 | C | ROD | WO-685785 |
| B | ARM | WO-685858 | D | RACK, INNER | WO-684972 |

NOTE: ALL PARTS LISTED ARE IN GROUP 1812 RA PD 367154

Figure 18-14. Litter racks (M170)

| KEY | ITEM | PART NO |
|-----|---------------|-----------|
| A | REST | WO-683013 |
| B | CUSHION, ASSY | WO-691543 |
| C | WASHER | 140241 |
| D | SCREW | 7418660 |

NOTE: ALL PARTS LISTED ARE IN GROUP 1812

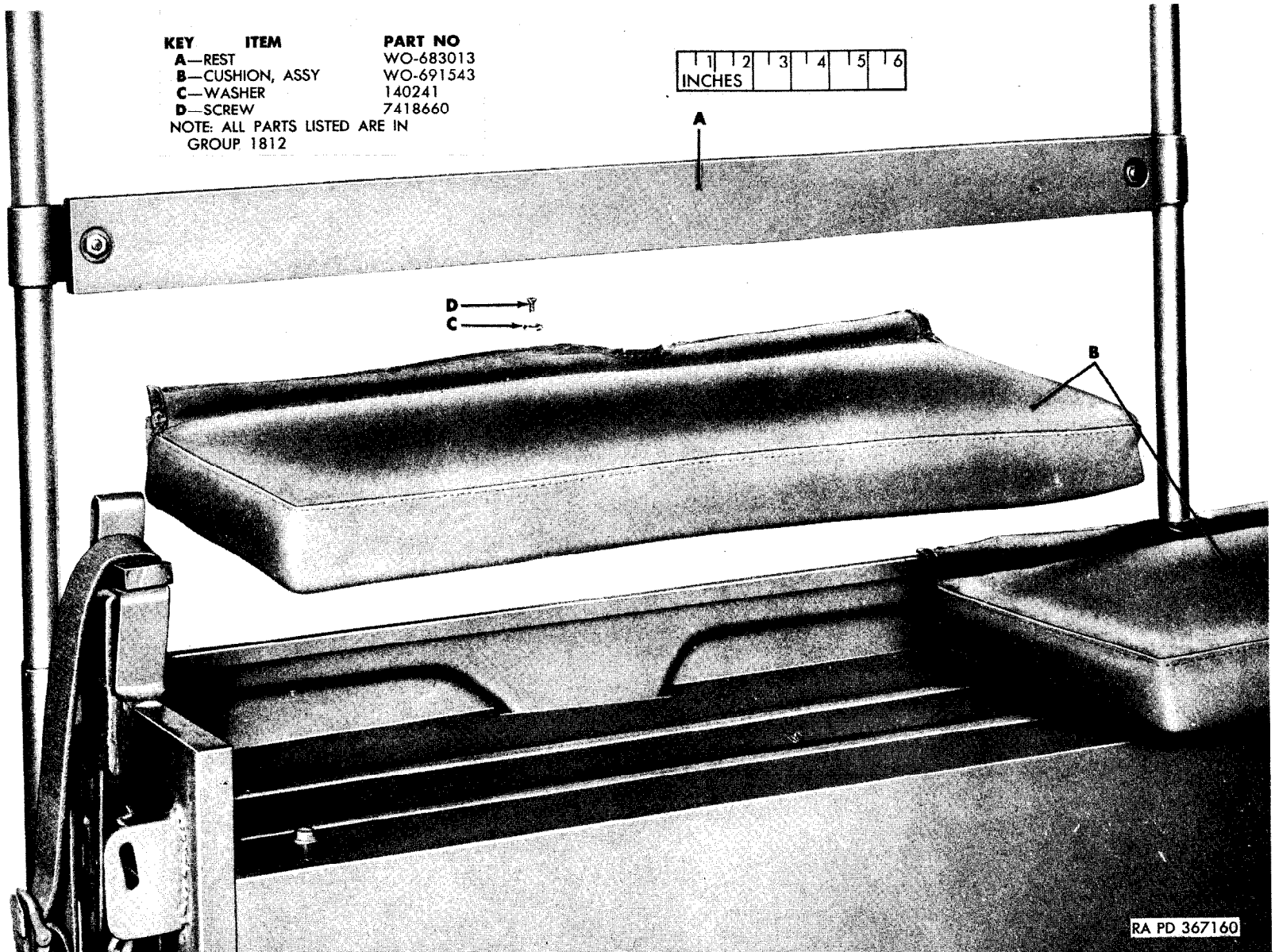
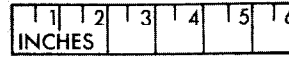

313

RA PD 367160

Figure 18-15. Wheel house cushion (M170)

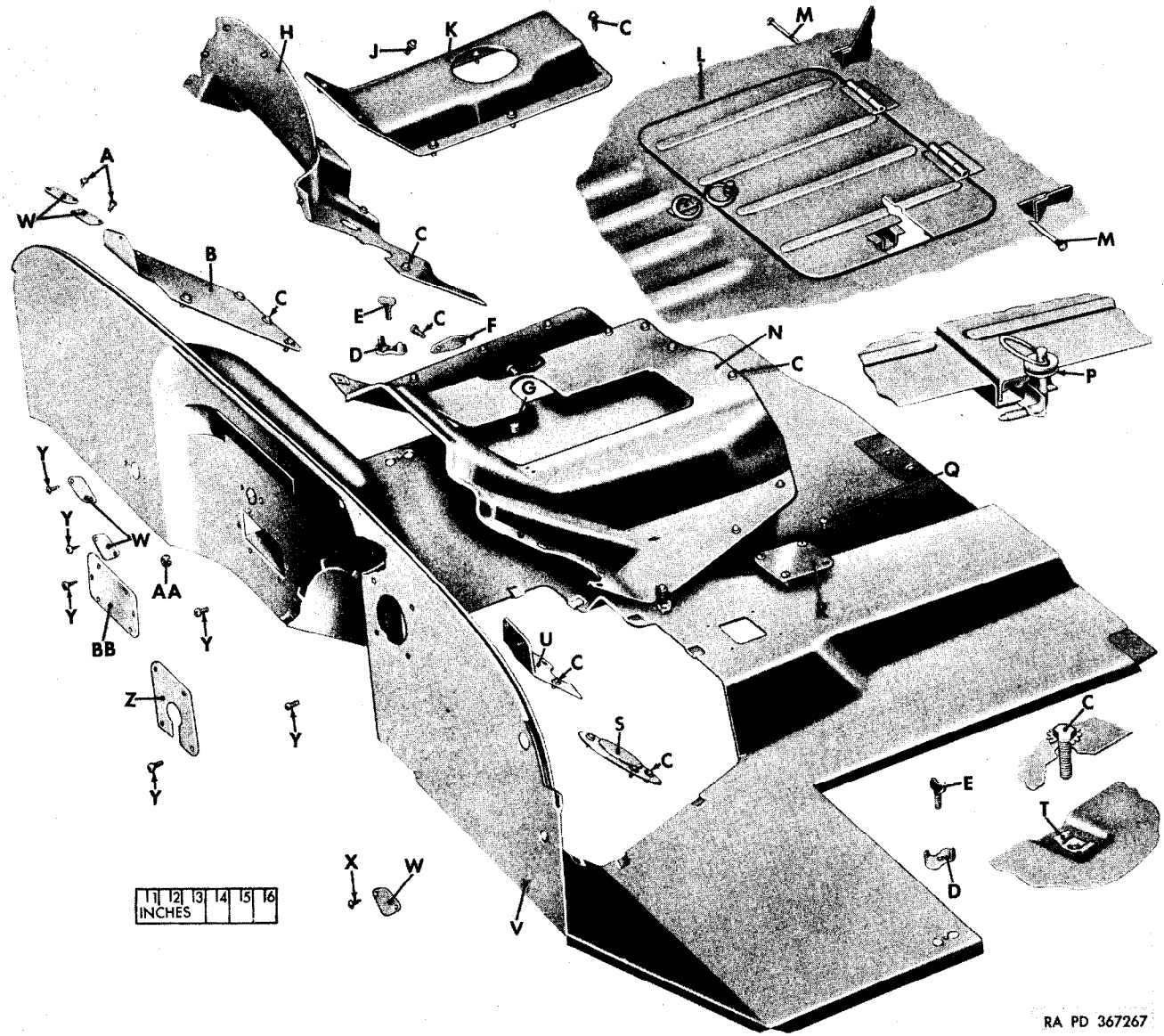

RA PD 367267

Figure 18-16. Floor plates and related parts

| <i>Key</i> | <i>Item</i> | <i>Part No.</i> | <i>Group</i> |
|------------|-------------------------|-----------------|--------------|
| A | —SCREW | 443882 | 1804 |
| B | —PLATE | 7697523 | 1805 |
| C | —BOLT, w/LOCK WASHER .. | 425380 | 1805 |
| D | —COVER, ASSY | 8331954 | 1805 |
| E | —SCREW | 7351314 | 1805 |
| F | —PLATE | 7697519 | 1805 |
| G | —PLUG | 7697581 | 1805 |
| H | —PLATE | WO-680506 | 1805 |
| J | —BOLT, w/LOCK WASHER .. | 425899 | 1805 |
| K | —COVER | 7697578 | 1805 |
| L | —LID | 8673345 | 1808 |
| M | —PIN | 7375166 | 1808 |
| N | —COVER | 7697525 | 1805 |
| P | —CATCH | 7375169 | 1808 |
| Q | —SCREW | 161895 | 1805 |
| R | —PLATE | 7375158 | 1805 |
| S | —COVER | 7697522 | 1805 |
| T | —NUT | 8329735 | 1805 |
| U | —PLATE | WO-685679 | 1805 |
| V | —PANEL | 8677606 | 1805 |
| W | —PLATE | 7418147 | 1804 |
| X | —SCREW | 161857 | 1804 |
| Y | —SCREW, w/LOCK WASHER | 454783 | 1804 |
| Z | —PLATE | 7418148 | 1804 |
| AA | —PLUG | 142083 | 1804 |
| BB | —PLATE | 8393228 | 1804 |

Figure 18-16. Floor plates and related parts—legend

1800

316

| (1) ILLUSTRATION NO. | (2) REFER- ENCE SYMBOLS | (3) FEDERAL STOCK NO. | (4) ORDNANCE STOCK NO. | (5) MFR'S PART NO. | (6) ORDNANCE PART NO. | (7) DESCRIPTION | (8) QUANTITY INCOR- PORATED IN UNIT | (9) UNIT OF ISSUE |
|---------------------------------|----------------------------------|-----------------------------|------------------------------|-----------------------|-----------------------------|---|---|----------------------------|
| GROUP 18-BODY | | | | | | | | |
| 1800-BODY ASSEMBLY | | | | | | | | |
| 18-1 | | | | WO-680637 | | BODY, complete, assy (includes BOWS, BRACES, BRACKETS, CLAMPS, COMPARTMENTS, HANDLES, tail LIGHTS, MIRROR, SEALS, SEATS, FLOORS, and PANELS) (painted) (M38A1) | 1 | ea |
| | | | | WO-685447 | | BODY, complete, painted, assy (includes BOWS, BRACES, BRACKETS, CLAMPS, COMPARTMENTS, HANDLES, tail LIGHTS, MIRROR, SEALS, SEATS, FLOOR, litter RACKS, and PANELS) (M170) | 1 | ea |
| 18-2, 3 | | | | WO-684560 | | BODY, assy (welded) (M170) | 1 | ea |
| | | | | WO-680956 | 8680884 | BODY (welded parts only) (painted) (M38A1) | 1 | ea |
| | | | | WO-685901 | | BODY, assy (painted) (M170) | 1 | ea |
| | | | | WO-684560 | | Composed of: | | |
| | | | | WO-684072 | | 1 BODY | | |
| | | | | | 7697592 | 1 GATE, tail | | |
| | | | | | 120377 | 2 HINGE | | |
| | | | | | 7697446 | 4 NUT | | |
| | | | | PEE-261 | 8673998 | 4 SCREW, w/lockwasher | | |
| | | | | WO-666197 | | SEALER, spot, body joints | † | ea |
| | | | | PEE-144.4 | 8676956 | SEALER, welding, body joints | † | ea |
| | | | | WO-671829 | | | | |
| 1801-BODY MOUNTING PARTS | | | | | | | | |
| | | 2530-770-1327 | G503-7701327 | WO-A4413 | 7701327 | CUSHION, ru, 3 lg, 1½ wide, ⅜ thk (No. 1 body hold-down) | 2 | ea |
| | | 2510-770-1328 | G503-7701328 | WO-A4414 | 7701328 | CUSHION, ru, 3 lg, 1½ wide, ⅛ thk (No. 2 body hold-down) | 2 | ea |
| | H1 | 012-0608 | H101-0120608 | | 120608 | BOLT, MACHINE, cap, hex-hd, S, cd- or zn-pltd, ⅜-24NF-3 x 2¼ | 2 | ea |
| | H1 | 012-0369 | H001-4167601 | | 120369 | NUT, PLAIN, HEXAGON, light, s-fin, S, cd- or zn-pltd, ⅜-24NF-2 | 2 | ea |
| | H1 | | H001-4040541 | | 503351 | NUT, safety, S, elastic stop, cd- or zn-pltd, ⅜-24NF-3 | 2 | ea |
| | H1 | 5310-012-0388 | H001-7045591 | | 120388 | WASHER, FLAT, pl, S, cd- or zn-pltd, ⅜ ID, 1 OD, 0.083 thk | 4 | ea |
| | | 2530-770-1327 | G503-7701327 | WO-A4413 | 7701327 | CUSHION, ru, 3 lg, 1½ wide, ⅜ thk (No. 4 body hold-down, left side only) | 1 | ea |

| | | | | | | | |
|----|---------------|--------------|----------|---------|--|---|----|
| | 2510-770-1328 | G503-7701328 | WO-A4414 | 7701328 | CUSHION, ru, 3 lg, 1½ wide, ⅛ thk (No. 4 body hold-down, right side only) | 1 | ea |
| H1 | | | | 442828 | NUT, self-locking, hex, "Huglock," S, cd- or zn-pltd, ⅜-24UNC-24B, ⅝ wide, 13 ₃₂ thk | 2 | ea |
| H1 | | H001-5421301 | | 121C15 | SCREW, cap, hex-hd, S, cd- or zn-pltd, ⅜-24NF-3 x 1¼ | 2 | ea |
| H1 | 5310-012-0388 | H001-7045591 | | 120388 | WASHER, FLAT, S, cd- or zn-pltd, ⅜ ID, 1 OD, 0.083 thk | 4 | ea |
| | 2510-770-1328 | G503-7701328 | WO-A4414 | 7701328 | CUSHION, ru, 3 lg, 1½ wide, ⅛ thk (No. 5 body hold-down) | 2 | ea |
| | 2530-770-1327 | G503-7701327 | WO-A4413 | 7701327 | CUSHION, ru, 3 lg, 1½ wide, ⅜ thk (No. 5 body hold-down) | 2 | ea |
| H1 | | H001-5421341 | | 120677 | BOLT, hex-hd, S, cd- or zn-pltd, ⅜-24NF-3 x 1½ | 4 | ea |
| H1 | | H001-4167601 | | 120369 | NUT, PLAIN, HEXAGON, light, s-fin, S, cd- or zn-pltd, ⅜-24NF-2 | 4 | ea |
| H1 | | H001-4040541 | | 503351 | NUT, SELF-LOCKING, S, elastic stop, cd- or zn-pltd, ⅜-24NF-3 | 4 | ea |
| H1 | 5310-012-0388 | H001-7045591 | | 120388 | WASHER, FLAT, S, cd- or zn-pltd, ⅜ ID, 1 OD, 0.083 thk | 4 | ea |
| | 2510-770-1328 | G503-7701328 | WO-A4414 | 7701328 | CUSHION, ru, 3 lg, 1½ wide, ⅛ thk (No. 6 body hold-down, inner and outer) | 4 | ea |
| H1 | 012-0232 | H001-3056951 | | 120232 | BOLT, sq, neck, step, S, cd- or zn-pltd, ⅝-18NC-2 x 1¾ | 2 | ea |
| H1 | | H001-4038521 | | 503271 | NUT, SELF-LOCKING, HEX, elastic stop, safety, S, cd- or zn-pltd, ⅝-18NC-3 | 2 | ea |
| H1 | 5310-010-7815 | H001-4056621 | | 107815 | NUT, STAMPED STEEL, jam, hex, reg, 6-notch, S, cd- or zn-pltd, ⅝-18NC | 2 | ea |
| H1 | 044-6363 | H101-0446363 | | 446363 | WASHER, FLAT, S, cd- or zn-pltd, ⅜ ID, ⅜ OD, 0.083 thk | 2 | ea |
| | 2510-770-1328 | G503-7701328 | WO-A4414 | 7701328 | CUSHION, ru, 3 lg, 1½ wide, ⅛ thk (No. 7 body hold-down, inner and outer) | 4 | ea |
| H1 | | H101-0213513 | | 213513 | NUT, PLAIN, hex, hv, s-fin, S, cd- or zn-pltd, ⅝-18NC-2 | 4 | ea |
| H1 | | H001-4038521 | | 503271 | NUT, SELF-LOCKING, safety, elastic stop, S, cd- or zn-pltd, ⅝-18NC-3 | 4 | ea |
| H1 | | H101-0122040 | | 122040 | SCREW, cap, hex-hd, S, cd- or zn-pltd, ⅝-18NC-3 x 1½ | 4 | ea |
| H1 | 044-6363 | H101-0446363 | | 446363 | WASHER, flat, S, cd- or zn-pltd, ⅜ ID, ⅜ OD, 0.083 thk | 8 | ea |
| | 2510-769-7513 | G740-7697513 | WO-A4416 | 7697513 | SHIM, ru, 2⅝ in. lg, 1½ in. wide, ⅛ in thk (No. 1 body hold-down) (use through vehicle serial No. 60406) | 2 | ea |
| H1 | | H001-5421261 | | 120647 | SCREW, cap, hex-hd, S, cd- or zn-pltd, ⅜-24NF-3 x 1 | 2 | ea |
| H1 | 5310-012-0382 | H001-7025741 | | 120382 | WASHER, lock, med, S, cd- or zn-pltd, ⅜ in. | 2 | ea |
| H1 | 5310-012-0388 | H001-7045591 | | 120388 | WASHER, FLAT, S, cd- or zn-pltd, ⅜ ID, 1 OD, 0.083 thk | 2 | ea |

1801

318

| (1) ILLUSTRATION NO. | (2) REFERENCE SYMBOLS | (3) FEDERAL STOCK NO. | (4) ORDNANCE STOCK NO. | (5) MFR'S PART NO. | (6) ORDNANCE PART NO. | (7) DESCRIPTION | (8) QUANTITY INCORPORATED IN UNIT | (9) UNIT OF ISSUE |
|---|--------------------------|--------------------------|---------------------------|-----------------------|--------------------------|--|--------------------------------------|----------------------|
| GROUP 18—BODY—Continued | | | | | | | | |
| 1801—BODY MOUNTING PARTS—Continued | | | | | | | | |
| | | 2510-769-7514 | G740-7697514 | WO-670540 | 7697514 | SHIM, ru, 3 lg, 1 1/2 wide, 1/4 thk (No. 3 body hold-down, right side only) | 1 | ea |
| | H1 | 012-0678 | H001-5421441 | | 120678 | BOLT, MACHINE, cap, hex-hd, S, cd- or zn-pltd, 3/8-24NF-3 x 2 | 1 | ea |
| | H1 | | | | 442828 | NUT, self-locking, hex, "Huglock," S, cd- or zn-pltd, 3/8-24UNF-2B, 9/16 wide, 13/32 thk | 1 | ea |
| | H1 | 5310-012-0388 | H001-7045591 | | 120388 | WASHER, flat, S, cd- or zn-pltd, 7/16 ID, 1 OD, 0.083 thk | 2 | ea |
| | | 2510-769-7514 | G740-7697514 | WO-670540 | 7697514 | SHIM, ru, 3 lg, 1 1/2 wide, 1/4 thk (No. 3 body hold-down, right side only) | 1 | ea |
| | H1 | 012-0608 | H101-0120608 | | 120608 | BOLT, MACHINE, cap, hex-hd, S, cd- or zn-pltd, 3/8-24NF-3 x 2 1/4 | 1 | ea |
| | H1 | | H001-4167601 | | 120369 | NUT, PLAIN, hex, light, s-fin, S, cd- or zn-pltd, 3/8-24NF-2 | 1 | ea |
| | H1 | | H001-4040541 | | 503351 | NUT, SELF-LOCKING, S, elastic stop, cd- or zn-pltd, 3/8-24NF-3 | 1 | ea |
| | H1 | 5310-012-0388 | H001-7045591 | | 120388 | WASHER, FLAT, S, cd- or zn-pltd, 7/16 ID, 1 OD, 0.083 thk | 1 | ea |
| | | | | WO-689537 | | STUD, drive, No. 6 x 7/16 (body sill cushion to front floor diagonal sill extension) | 4 | ea |
| 1803.1—TAILGATE (M170) | | | | | | | | |
| | | | | WO-672592 | | COVER, hook w/CHAIN | 2 | ea |
| | | | G740-7697592 | WO-673621 | 7697592 | HINGE, tailgate | 2 | ea |
| | H1 | | H001-4167581 | | 120377 | NUT, hex, lt, s-fin, cd- or zn-pltd, 3/8-16NC-2 | 4 | ea |
| | | | G740-7697446 | WO-673501 | 7697446 | SCREW, lock washer, hex-hd, S, cd- or zn-pltd, 3/8-16NC x 1 | 4 | ea |
| | | | | WO-684131 | | HOOK, w/CHAIN, left | 1 | ea |
| | | | | WO-684132 | | HOOK, w/CHAIN, right | 1 | ea |
| | | | | | 111893 | RIVET, tubular, oval-hd, S, plain, 9/64 x 1/2 | 4 | ea |
| | H1 | 5310-013-1014 | H001-7043561 | | 131014 | WASHER, FLAT, S, cd- or zn-pltd, 5/32 ID, 3/8 OD, 0.049 thk | 4 | ea |
| 18-5 | | | | WO-684129 | | HOOK, w/CHAIN, tailgate left, assy | 1 | ea |
| | | | | WO-672592 | | Composed of: | | |
| | | | | WO-684131 | | 1 COVER | | |
| | | | | | | 1 HOOK, w/CHAIN | | |
| | | | | | 111893 | 2 RIVET | | |

| | | | | | | | |
|------|---------------|--------------|--|--------------------|---|------------------|----------------------|
| 18-5 | | | WO-684130 | 131014 | 2 WASHER HOOK, w/CHAIN, tailgate right, assy | 1 | ea |
| | | | WO-672592 WO-684132 | | Composed of: 1 COVER 1 HOOK, w/CHAIN 2 RIVET 2 WASHER | | |
| | | | WO-663194 WO-663195 | 111893 131014 | LOCK, half, tailgate, gate half, left LOCK, half, tailgate, gate half, right | 1 1 | ea ea |
| H2 | | H002-7697591 | | 7697591 | LOOP, footman (tailgate) | 2 | ea |
| H1 | 015-5937 | H101-0155937 | | 155937 | BOLT, mach, cross-recess, fl-hd, S, cd- or zn-pltd, No. 10 (0.190)-24NC-2 x 1/2 | 4 | ea |
| H1 | | H101-0271166 | | 271166 | NUT, hex, ext-teeth lock washer, S, cd- or zn-pltd, No. 10-24NC-2A | 4 | ea |
| H2 | | H002-8328423 | | 8328423 | LOOP, footman, 1 1/2 in. strap size (tailgate) | 1 | ea |
| H1 | | H101-0155937 | | 155937 | BOLT, mach, cross-recess, fl-hd, S, cd- or zn-pltd, No. 10 (0.190)-24NC-2 x 1/2 | 2 | ea |
| H1 | | H101-0271166 | | 271166 | NUT, hex, ext-teeth lock washer, S, cd- or zn-pltd, No. 10-24NC-2A | 2 | ea |
| | | G740-7697447 | WO-663428 WO-685838 WO-684155 WO-684072 | 7697447 | PIN, S, 3/16 dia, 7 lg (tailgate hinge) STOP, lower, litter tail gate (welded) SUPPORT, inner rear, auxiliary, litter (welded) TAILGATE (welded) | 2 1 1 1 | ea ea ea ea |
| 18-5 | | | | | 1804—BODY PANELS, PILLARS, AND WINDSHIELD | | |
| | | | WO-680565 WO-680751 WO-680752 | | BRACKET, catch, hood to windshield BRACKET, door hinge upper left (M170) BRACKET, door hinge upper right (M170) | 1 1 1 | ea ea ea |
| | | | H101-0425384 | 425384 | SCREW, int-teeth-lock washer, hex-hd, header-pt, S, cd- or zn-pltd, 1/4-20NC-2 x 1 1/4 | 4 | ea |
| | | | WO-673325 WO-673339 | 8680526 7697497 | BRACKET, No. 6 body hold-down outer and tail light BRACKET, pivot rear seat | 2 2 | ea ea |
| 18-9 | 2510-769-7497 | G740-7697497 | | 7697497 | | | |
| 18-9 | H1 042-5379 | H101-0425379 | | 425379 | BOLT, int-teeth lock washer, hex-hd, header-pt, S, cd- or zn-pltd, 1/4-20NC-2 x 1/2 | 4 | ea |
| 18-7 | | | WO-685739 | | BRACKET, stowage, litter (windshield) (welded) (M170) | 1 | ea |
| 18-7 | | | WO-685468 | | BRACKET, stowage, passenger seat cushion (windshield) (welded) (M170) | 2 | ea |
| | | | WO-684914 | | BRACKET, support, hood hinge, w/weld NUTS (used on vehicles after serial No. 60406) | 1 | ea |
| | 5305-769-7440 | G740-7697440 | WO-673597 | 7697440 | BOLT, INTEGRAL LOCK WASHER, ext-teeth, hex-hd, S, cd- or zn-pltd, 5/16-18NC-2 x 5/8 (superseded by SCREW 425388) (hood hinge support bracket and rad tie rod) | 3 | ea |
| | | | | 425388 | SCREW, int-teeth-lock washer, hex-hd, header-pt, S, cd- or zn-pltd, 5/16-18NC-2 x 5/8 (supersedes BOLT 7697440) | 3 | ea |

1804

| (1) ILLUSTRATION NO. | (2) REFER- ENCE SYMBOLS | (3) FEDERAL STOCK NO. | (4) ORDNANCE STOCK NO. | (5) MFR'S PART NO. | (6) ORDNANCE PART NO. | (7) DESCRIPTION | (8) QUANTITY INCOR- PORATED IN UNIT | (9) UNIT OF ISSUE |
|--|----------------------------------|-----------------------------|------------------------------|-----------------------|-----------------------------|--|---|----------------------------|
| GROUP 18—BODY—Continued | | | | | | | | |
| 1804—BODY PANELS, PILLARS, AND WINDSHIELD—Continued | | | | | | | | |
| 18-8 | | | | WO-680821 | 8393203 | BRACKET, support, side rail, left, top to windshield..... | 1 | ea |
| 18-8 | | | | WO-680822 | | BRACKET, support, side rail, right, top to windshield..... | 1 | ea |
| 18-8 | H1 | | H101-0454783 | | 454783 | SCREW, assembled washer, cross-recess-pan-hd, int- teeth lock washer, header-pt, S, cd- or zn-pltd, No. 10 (0.190)-24NC-2A x 1/2 | 4 | ea |
| 18-7 | | | | WO-685456 | | BRACKET, support, stabilizer board (welded) (M170)..... | 1 | ea |
| | | | | WO-680239 | 8393194 | BRACKET, tail light and trailer connection to body side panel | 1 | ea |
| | | | | WO-684917 | | BRACKET, tie rod, dash, left (welded) (used on vehicles after serial No. 60406) | 1 | ea |
| | | | | WO-684918 | | BRACKET, tie rod, dash, right (welded) (used on vehicles after serial No. 60406) | 1 | ea |
| | | | | WO-681005 | | BRACKET, windshield to hood bumper, left..... | 1 | ea |
| | | | | WO-681006 | | BRACKET, windshield to hood bumper, right..... | 1 | ea |
| | H2 | | H002-0585861 | | 585861 | BUCKLE, tongueless, S, 1 in. (windshield hold-down strap) | 1 | ea |
| 18-8 | | | G758-8328464 | WO-681003 | 8328464 | BUMPER, windshield to hood, left, assy..... | 1 | ea |
| | | | | WO-681005 | | Composed of: | | |
| | | | | WO-680641 | | 1 BRACKET | | |
| | | | | | 113454 | 1 LINER | | |
| | | | | | 8328465 | 4 RIVET | | |
| 18-8 | | | G758-8328465 | WO-681004 | 8328465 | BUMPER, windshield to hood, right, assy..... | 1 | ea |
| | | | | WO-681006 | | Composed of: | | |
| | | | | WO-680641 | | 1 BRACKET | | |
| | | | | | 113454 | 1 LINER | | |
| | | | | | 425379 | 4 RIVET | | |
| 18-8 | H1 | 042-5379 | H101-0425379 | | 425379 | BOLT, int-teeth lock washer, hex-hd, header-pt, S, cd- or zn-pltd, 1/4-20NC-2 x 1/2 | 4 | ea |
| | | | | WO-680566 | | CATCH, hood to windshield..... | 1 | ea |
| 18-8 | | | G758-8328468 | WO-680607 | 8328468 | CATCH, hood to windshield, assy..... | 1 | ea |
| | | 5805-737-2885 | G740-7372885 | WO-673600 | 7372885 | SCREW, int-teeth-lock washer, hex-hd, header-pt, S, cd- or zn-pltd, 1/4-20NC-2 x 5/8 (superseded by SCREW 425380) | 2 | ea |
| 18-8 | H1 | | H101-0425380 | | 425380 | SCREW, int-teeth-lock washer, hex-hd, header-pt, S, cd- or zn-pltd, 1/4-20NC-2 x 5/8 (supersedes SCREW 7372885) | 2 | ea |

320

| | | | | | | | | |
|---------|----|---------------------------|------------------------------|-------------------------|-------------------|--|---|----|
| | H1 | 2510-737-5312 015-6253 | G740-7375312 H101-0156253 | WO-673553 | 7375312 156253 | CATCH, windshield clamp..... | 2 | ea |
| | H1 | | G758-8329779 H101-0454789 | WO-680130 | 8329779 454789 | SCREW, mach, cross-recess-fl-hd, S, cd- or zn-pltd, 1/4-20NC-2 x 3/4 | 4 | ea |
| | | | | | | CUP, opening, fuel tank filler neck..... | 1 | ea |
| 18-8 | | | | IND-33197R WO-680993 | | SCREW, assembled washer, cross-recess-pan-hd, int- teeth-lock washer, header-pt, S, cd- or zn-pltd, 1/4-20UNC-2A x 1/2 | 7 | ea |
| 18-8 | | | G758-8329651 | WO-680427 | 8329651 | FILLER, windshield glass center bar weatherstrip (ru) (approx 13 in. lg) | 1 | ea |
| 18-6, 8 | | | G758-8329652 | WO-680559 | 8329652 | FILLER, windshield glass weatherstrip (ru) (approx 134 in. lg) | 1 | ea |
| 18-6, 8 | H9 | | H009-0837045 | WO-680559 | 59-G-673 | FRAME, windshield, assy..... | 1 | ea |
| | | | | | | GLASS, safety, vinyl plastic shatterproof, plate, dble strength, 1/4 in. thk, 16 in. width, 50 in. lg | 2 | ea |
| | | | | WO-680146 | | HINGE, glove box, instrument panel half..... | 1 | ea |
| | | | | WO-680951 | 8393204 | HINGE, hood, cowl half, left..... | 1 | ea |
| | | | | WO-680952 | | HINGE, hood, cowl half, right..... | 1 | ea |
| | | 5305-769-7440 | G740-7697440 | WO-673597 | 7697440 | BOLT, INTEGRAL LOCK WASHER, ext-teeth, hex- hd, S, cd- or zn-pltd, 5/16-18NC-2 x 5/8 (pt) (super- seded by SCREW 425388) | 4 | ea |
| | H1 | | H101-0425388 | | 425388 | SCREW, int-teeth-lock washer, hex-hd, header-pt, S, cd- or zn-pltd, 5/16-18NC-2 x 5/8 (supersedes BOLT 7697440) | 4 | ea |
| 18-8 | | | | WO-681457 | 8677403 | HINGE, windshield (windshield half, left)..... | 1 | ea |
| 18-8 | | | | WO-681458 | 8392985 | HINGE, windshield (windshield half, right)..... | 1 | ea |
| 18-8 | H1 | 042-5338 | H101-0425338 | | 425338 | BOLT, int-teeth-lock washer, hex hd, S, cd- or zn- pltd, 5/16-18NC-2 x 1 | 4 | ea |
| 18-8 | H1 | | | | 443775 | SCREW, assembled washer, cross-recess-pan-hd, ext- teeth lock washer, S, cd- or zn-pltd, 5/16-18UNC-2A x 3/4 | 6 | ea |
| | | | | WO-681455 | 8677402 | HINGE, windshield, w/PIN, assy (cowl half, left)..... | 1 | ea |
| | | | | WO-681456 | | HINGE, windshield, w/PIN, assy (cowl half, right)..... | 1 | ea |
| | | | | WO-680439 | | SCREW, mach, special, cross recess-spiral-ribbed-flat- hd, S, cd- or zn-pltd, 5/16-24NF-3 x 3/4 | 8 | ea |
| | | | | WO-680641 | | LINER, channel anti-squeak, 6.38 lg, 3/4 wide, 5/16 thk (windshield to hood bumper) | 2 | ea |
| | H1 | | | | 113454 | RIVET, split, oval-hd, S, blk-enmld, 5/64 x 1/16, 5/16 hd dia | 8 | ea |
| 18-6, 8 | | | G758-8329653 | WO-680398 | 8329653 | LOCK, windshield, assy (clamp type)..... | 2 | ea |
| 18-6, 8 | H1 | | H101-9409107 | | 9409107 | BOLT, MACHINE, assembled washer, hex-hd, split lock washer, S, cd- or zn-pltd, 1/4-20UNC-2A x 5/8 | 6 | ea |

| (1) ILLUSTRATION NO. | (2) REFER- ENCE SYMBOLS | (3) FEDERAL STOCK NO. | (4) ORDNANCE STOCK NO. | (5) MFR'S PART NO. | (6) ORDNANCE PART NO. | (7) DESCRIPTION | (8) QUANTITY INCOR- PORATED IN UNIT | (9) UNIT OF ISSUE |
|--|----------------------------------|-----------------------------|------------------------------|--------------------------------------|-----------------------------|---|---|----------------------------|
| GROUP 18—BODY—Continued | | | | | | | | |
| 1804—BODY PANELS, PILLARS, AND WINDSHIELD—Continued | | | | | | | | |
| 18-7, 8 | H2 | | H002-7697591 | | 7697591 | LOOP, footman, drilled, 1 $\frac{3}{32}$ in., 1 in. strap size (instru- ment panel (3) body side panel (10) windshield frame (1) cowl panel (1) (used on vehicles after serial No. 63252 only) | 15 | ea |
| | H1 | 015-5937 | H101-0155937 | | 155937 | BOLT, MACHINE, cross-recess, fl-hd, S, cd- or zn- pltd, No. 10 (0.190)-24NC-2 x $\frac{1}{2}$ (2 required per loop) | 30 | ea |
| | H1 | | H101-0271166 | | 271166 | NUT, hex, ext-teeth lock washer, S, cd- or zn-pltd, No. 10-24NC-2A (2 required per loop) | 30 | ea |
| | H1 | 015-5937 | H101-0155937 | WO-681786 | 155937 | LOOP, footman (body side panel, rear) | 2 | ea |
| | H1 | | H101-0271166 | | 271166 | BOLT, MACHINE, cross-recess, fl-hd, S, cd- or zn- pltd, No. 10 (0.190)-24NC-2 x $\frac{1}{2}$ | 4 | ea |
| | H1 | | H101-0271166 | | 271166 | NUT, hex, ext-teeth lock washer, S, cd- or zn-pltd, No. 10-24NC-2A | 4 | ea |
| | H1 | 015-5937 | H101-0155937 | EB-6411G WO-684730 | 155937 | LOOP, footman, drilled, 2.120 in. (battery box cowl lid) (used on vehicles after serial No. 63252) | 1 | ea |
| | H1 | | H101-0271166 | | 271166 | BOLT, MACHINE, cross recess-fl-hd, S, cd- or zn- pltd, No. 10 (0.190)-24NC-2 x $\frac{1}{2}$ | 2 | ea |
| | H2 | | H002-8328423 | | 8328423 | NUT, hex, ext-teeth-lock washer, S, cd- or zn-pltd, No. 10-24NC-2A | 2 | ea |
| | H1 | 015-5937 | H101-0155937 | | 155937 | LOOP, footman (rear body panel) | 1 | ea |
| | H1 | | H101-0271166 | | 271166 | BOLT, MACHINE, cross-recess, fl-hd, S, cd- or zn- pltd, No. 10 (0.190)-24NC-2 x $\frac{1}{2}$ | 2 | ea |
| 18-7 | | | | WO-685721 | | NUT, hex, ext-teeth lock washer, S, cd- or zn-pltd, No. 10-24NC-2A | 2 | ea |
| 18-8 | H1 | | | | 162688 | LOOP, footman, w/SHIELD, door stowage (welded) (M170) | 2 | ea |
| | | | | WO-680569 | | SCREW, tapping, cross-recess, fl-hd, blunt-pt, sh-met- thd, S, cd- or zn-pltd, No. 10 (0.186) x $\frac{5}{8}$ in. | 2 | ea |
| | | | | WO-669904 | 8673999 | NUT, sq, S, cd- or zn-pltd, $\frac{5}{16}$ -24NF (cowl pillar, left (2), cowl pillar, right (3), rear cowl panel (4)) | 9 | ea |
| | | | | ONB-SN2716 WO-680445 WO-682637 | | NUT, weld, S, $\frac{5}{16}$ -18NC (body side panel left (3), right (3)) | 6 | ea |
| | | | | | | NUT, weld, S, $\frac{5}{16}$ -18NC (body side panel, left (1), body side panel, right (1)) | 2 | ea |
| | | | | | | NUT, weld, S, $\frac{5}{16}$ -18NC (body side panel left top channel reinforcement) | 1 | ea |

| | | | | | | | |
|--|--|--|------------|---------|---|----|----|
| | | | ONB-SN3318 | | NUT, weld, S, 3/4-16NC (instrument panel)..... | 2 | ea |
| | | | WO-680446 | | | | |
| | | | WO-674267 | | NUT, weld, S, 1/4-20NC (rear body panel)..... | 6 | ea |
| | | | ONB-SN1610 | 8677317 | NUT, weld, S, No. 10-24NC (side rail support bracket | 6 | ea |
| | | | WO-674898 | | (4), defrost chamber windshield top panel (2)) | | |
| | | | ONB-SN2113 | | NUT, weld, S, 1/4-20NC (wheelhouse panel, left (5), | 68 | ea |
| | | | WO-674350 | | wheelhouse panel, right (7), body side panel, left (13), | | |
| | | | | | body side panel, right (10), rear body panel inner rein- | | |
| | | | | | forcement (4), cowl pillar, left (2), cowl pillar, right (2), | | |
| | | | | | front cowl panel (8), rear cowl panel reinforcement (7), | | |
| | | | | | windshield clamp reinforcement (6), windshield frame | | |
| | | | | | (4)) | | |
| | | | | 451748 | NUT, weld, S, 5/16-18NC (side panel reinforcement, | 2 | ea |
| | | | | | left (1), right (1)) (used on vehicles after serial No. | | |
| | | | | | 60406) | | |
| | | | WO-680629 | 8677629 | PANEL, body, left side (welded) (M38A1)..... | 1 | ea |
| | | | WO-684253 | | PANEL, body, left side, assy (welded) (M170)..... | 1 | ea |
| | | | WO-681184 | | PANEL, body, rear, w/weld NUTS, assy..... | 1 | ea |
| | | | WO-680630 | | PANEL, body, right side (welded) (M38A1)..... | 1 | ea |
| | | | WO-684241 | | PANEL, body, right side, assy (welded) (M170)..... | 1 | ea |
| | | | WO-680634 | 8677594 | PANEL, cowl, assy (welded) (includes front and rear | 1 | ea |
| | | | | | PANELS) (used through vehicles serial No. 60406) | | |
| | | | WO-685071 | | PANEL, cowl, assy (welded) (includes front and rear | 1 | ea |
| | | | | | PANELS) (used on vehicles after serial No. 60406 and | | |
| | | | | | through serial No. 63252) | | |
| | | | WO-684810 | | PANEL, cowl, assy (welded) (includes front and rear | 1 | ea |
| | | | | | PANELS) (used on vehicles after serial No. 63252) | | |
| | | | WO-680632 | 8677558 | PANEL, cowl, front (includes tapping PLATES and weld | 1 | ea |
| | | | | | NUTS) (used through vehicles serial No. 60406) | | |
| | | | WO-685056 | | PANEL, cowl, front (includes tapping PLATE and weld | 1 | ea |
| | | | | | NUTS) (used after vehicles serial No. 60406 and | | |
| | | | | | through serial No. 63252) | | |
| | | | WO-684834 | | PANEL, cowl, front (includes tapping PLATE and weld | 1 | ea |
| | | | | | NUTS) (used on vehicles after serial No. 63252) | | |
| | | | WO-680241 | | PANEL, cowl, rear..... | 1 | ea |
| | | | WO-680633 | 8677559 | PANEL, cowl, rear (includes RETAINER and NUTS).... | 1 | ea |
| | | | WO-680416 | 8677599 | PANEL, instrument, assy..... | 1 | ea |
| | | | WO-673600 | 7372885 | SCREW, int-teeth-lock washer, hex-hd, header-pt, S, | 11 | ea |
| | | | | | cd- or zn-pltd, 1/4-20NC-2 x 5/8 (superseded by | | |
| | | | | | SCREW 425380) | | |
| | | | | | SCREW, int-teeth-lock washer, hex-hd, header-pt, S, | 11 | ea |
| | | | | | cd- or zn-pltd, 1/4-20NC-2 x 5/8 (supersedes SCREW | | |
| | | | | | 7372885) | | |
| | | | WO-683955 | | PANEL, instrument, assy (M170)..... | 1 | ea |
| | | | WO-680627 | 8677557 | PANEL, wheelhouse, left (welded) (M38A1)..... | 1 | ea |
| | | | WO-684189 | | PANEL, wheelhouse, left (welded) (M170)..... | 1 | ea |
| | | | WO-680628 | | PANEL, wheelhouse, right (welded) (M38A1)..... | 1 | ea |

H1

5305-737-2885

G740-7372885

H101-0425380

| (1) ILLUSTRATION NO. | (2) REFER- ENCE SYMBOLS | (3) FEDERAL STOCK NO. | (4) ORDNANCE STOCK NO. | (5) MFR'S PART NO. | (6) ORDNANCE PART NO. | (7) DESCRIPTION | (8) QUANTITY INCOR- PORATED IN UNIT | (9) UNIT OF ISSUE |
|--|----------------------------------|-----------------------------|------------------------------|-----------------------|-----------------------------|---|---|----------------------------|
| GROUP 18—BODY—Continued | | | | | | | | |
| 1804—BODY PANELS, PILLARS, AND WINDSHIELD—Continued | | | | | | | | |
| | | | | WO-684190 | | PANEL, wheelhouse, right (welded) (M170)..... | 1 | ea |
| | | | | WO-680283 | 8677639 | PILLAR, cowl, left, w/NUTS and RETAINERS, assy (M38A1) | 1 | ea |
| | | | | WO-685434 | | PILLAR, cowl, left, w/NUTS and RETAINERS, assy (M170) | 1 | ea |
| | | | | WO-680284 | | PILLAR, cowl, right, w/NUTS and RETAINERS, assy. | 1 | ea |
| | | | | WO-681440 | | PIN, hinge, S, cd- or zn-pltd, 0.437 dia x 3.75 lg (wind- shield hinge) | 2 | ea |
| | | | | WO-680568 | | PIN, roll, S, cd- or zn-pltd, 0.250 dia x 1.12 lg (windshield hood catch) | 1 | ea |
| 18-16 | | 2510-741-8148 | G740-7418148 | WO-677712 | 7418148 | PLATE, cover, dash panel (cable opening)..... | 1 | ea |
| 18-16 | H1 | | H101-0454783 | | 454783 | SCREW, assembled washer, cross-recess-pan-hd, int- teeth lock washer, header-pt, S, cd- or zn-pltd, No. 10 (0.190)-24NC-2A x 1/2 | 4 | ea |
| 18-16 | | | | WO-681268 | 8393228 | PLATE, cover, dash panel (personnel heater)..... | 1 | ea |
| 18-16 | H1 | 5305-016-1857 | H101-0161857 | | 161857 | SCREW, tapping, cross-recess-pan-hd, gimlet-pt, sh- met-thds, S, cd- or zn-pltd, No. 8 (0.165) x 3/8 | 6 | ea |
| 18-16 | | 2510-741-8147 | G740-7418147 | WO-677277 | 7418147 | PLATE, cover, dash panel (water tube holes (2), con- veyor hole (1), and slave receptacle wiring holes (2)) | 5 | ea |
| 18-16 | H1 | 5305-016-1857 | H101-0161857 | | 161857 | SCREW, tapping, cross-recess-pan-hd, gimlet-pt, sh- met-thd, S, cd- or zn-pltd, No. 8 (0.165) x 3/8 (water tube cover plate (4) and conveyor hole cover plate (2)) | 6 | ea |
| 18-16 | | | | | 443882 | SCREW, tapping, hex-hd, gimlet-pt, sh-met-thd, S, cd- or zn-pltd, No. 8 (0.165) x 3/8 (slave receptacle cover plate) | 4 | ea |
| | | | | WO-685388 | | PLATE, cover, trailer receptacle opening (body rear panel) (M170) | 1 | ea |
| | H1 | | H101-0454789 | | 454789 | SCREW, int-teeth lock washer, truss head, cross-recess, S, cd- or zn-pltd, 1/4-20NC x 1/2 (cover plate to left hand rear body panel) | 4 | ea |
| | | | | WO-680402 | | PLATE, tapping, hood hinge, cowl half (1) (used after vehicle serial No. 60406 left side only) | 2 | ea |
| | | | | WO-680406 | | PLATE, tapping, rear view mirror (in cowl)..... | 1 | ea |
| | | | | WO-672616 | 7954266 | PLATE, tapping, windshield clamp catch (to instrument panel) | 2 | ea |

| | | | | | | | | |
|-------|----|---------------|--------------|-----------|--|--|----|----|
| | | | WO-680266 | | PLATE, tapping, windshield hinge (defrost chamber windshield bottom panel) | 2 | ea | |
| | H2 | | H102-0492487 | 432487 | PLUG, button, S, cd- or zn-pltd, 1 $\frac{1}{16}$ dia hole size (for 0.037 to 0.062 thk material) (dual control on instrument panel) (superseded by PLUG 8332574) (used on vehicles after serial No. 23359 and through serial No. 43035) | 1 | ea | |
| | | | G758-8332574 | WO-809596 | 8332574 | PLUG, button, S, 1 $\frac{1}{16}$ dia hole size (for 0.037 to 0.062 thk material) (painted) (dual control on instrument panel) (supersedes PLUG 432487) (used on vehicles after serial No. 43035) | 1 | ea |
| 18-16 | | | UC-48155 | 142083 | PLUG, button, S, 7 $\frac{1}{8}$ dia hole size (for 0.047 to 0.093 thk material) (painted) (primer hole in dash panel) | 1 | ea | |
| | | | WO-806673 | | | | | |
| | | | WO-806674 | | PLUG, button, S, 3 $\frac{1}{4}$ dia hole size (for 0.037 to 0.093 thk material) (painted) (primer hole in instrument panel) | 1 | ea | |
| | | | WO-681181 | | REINFORCEMENT, channel, body side panel top rear corner | 2 | ea | |
| | | | WO-681512 | | REINFORCEMENT, hood catch (windshield panel)..... | 1 | ea | |
| | | | WO-681037 | | REINFORCEMENT, passenger seat safety rail, w/weld NUTS, assy (on instrument panel) | 2 | ea | |
| | | | WO-680302 | | REINFORCEMENT, rear cowl panel, w/weld NUTS, assy | 1 | ea | |
| | | | WO-684555 | | REINFORCEMENT, rear cowl panel, w/weld NUTS, assy (M170) | 1 | ea | |
| | | | WO-683573 | | REINFORCEMENT, spare wheel mtg bolt (rear panel) (used on vehicles after serial No. 35896) | 1 | ea | |
| | | | G758-8329756 | 8329756 | RETAINER, canvas top to windshield frame (welded).... | 1 | ea | |
| 18-7 | | | WO-680128 | 8677552 | RETAINER, door curtain, left (M170)..... | 1 | ea | |
| | | | WO-680371 | 163600 | SCREW, tapping, cross-recess-pan-hd, conical, pilot-pt, sh-met-thd, S, cd- or zn-pltd, No. 10 (0.186) x 1 $\frac{1}{2}$ (retainer to windshield frame) | 4 | ea | |
| 18-7 | | | WO-680372 | | RETAINER, door curtain, right (M170)..... | 1 | ea | |
| | | | | 163600 | SCREW, tapping, cross-recess-pan-hd, conical pilot-pt, sh-met-thd, S, cd- or zn-pltd, No. 10 (0.186) x 1 $\frac{1}{2}$ (retainer to windshield frame) | 4 | ea | |
| | | 2510-769-7548 | G740-7697548 | WO-A3549 | 7697548 | RETAINER, sq-nut, 5 $\frac{1}{16}$ (cowl pillar, left (2), cowl pillar, right (3), rear cowl panel (4)) | 9 | ea |
| | H1 | | H101-0454783 | | 454783 | SCREW, assembled washer, cross-recess-pan-hd, int-teeth lock washer, header-pt, S, cd- or zn-pltd, No. 10 (0.190)-24NC-2A x 1 $\frac{1}{2}$ (door fastener hole plug in left rear cowl panel (2)), deep water vent system holes in dash (2) (used on vehicles after serial No. 23359)) | 4 | ea |
| | H1 | 012-0361 | H001-4135661 | | 120361 | NUT, mach screw, hex, S, cd- or zn-pltd, No. 10 (0.190)-24NC-2 (door fastener hole plug only) | 2 | ea |

| (1) ILLUSTRATION NO. | (2) REFERENCE SYMBOLS | (3) FEDERAL STOCK NO. | (4) ORDNANCE STOCK NO. | (5) MFR'S PART NO. | (6) ORDNANCE PART NO. | (7) DESCRIPTION | (8) QUANTITY INCORPORATED IN UNIT | (9) UNIT OF ISSUE |
|--|--------------------------|---------------------------|------------------------------|--|-----------------------------|--|--------------------------------------|----------------------|
| GROUP 18—BODY—Continued | | | | | | | | |
| 1804—BODY PANELS, PILLARS, AND WINDSHIELD—Continued | | | | | | | | |
| 18-8 | H1 | | H101-0425384 | | 425384 | SCREW, int-teeth lock washer, hex-hd, header-pt, S, cd- or zn-pltd, ¼-20NC-2 x 1 ⅛ (upper door hinge hole plugs) | 4 | ea |
| 18-8 | H1 | 012-0375 5330-734-8567 | H001-4167501 G740-7348567 | PEE-577-2 WO-94096 WO-680575 WO-663079 WO-681275 | 120375 7348567 | NUT, hex, lt, s-fin, S, cd- or zn-pltd, ¼-20NC-2 SEAL, strip type, ⅜ dia bead x 80 ft lg (windshield) | 4 ‡ | ea ft |
| | | | G758-8329988 | WO-681274 | 8329988 | SPRING, catch, hood to windshield STRAINER, inner rear body panel to frame STRAP, hold-down, windshield (M170) STRAP, hold-down windshield, w/BUCKLE, assy (M170) | 1 2 1 1 | ea ea ea ea |
| | H1 | | G758-8329656 H101-0454783 | WO-681275 WO-A2602 WO-680144 | 585861 8329656 454783 | Composed of: 1 BUCKLE 1 STRAP 1 TIP STRIKER, glove box door SCREW, assembled washer, cross-recess-pan-hd, int-teeth-lock washer, header-pt, S, cd- or zn-pltd, No. 10 (0.190)-24NC-2A x ½ | 1 1 | ea ea |
| | | | | UC-78316 WO-687682 WO-A2602 WO-804373 | | STUD, turn button (canvas top) (M170) TIP, strap end (windshield hold-down strap) WASHER, FLAT, S, ⅝ ID, 1 ⅛ OD, ⅛ thk (rear body panel) (used on vehicles through serial No. 35896) | 2 1 2 | ea ea ea |
| 18-8 | H1 | 5310-012-0391 | H001-7043621 | | 120391 | WASHER, FLAT, S, cd- or zn-pltd, ⅞ ID, ½ OD, 0.049 thk | 13 | ea |
| 18-6, 8 | | | G758-8329659 | WO-680430 | 8329659 | WEATHERSEAL, ru, 134.74 in. lg (windshield glass) | 1 | ea |
| 18-8 | | | G758-8329658 | WO-680505 | 8329658 | WEATHERSEAL, ru, 58.92 in. lg (windshield to cowl) | 1 | ea |
| 18-8 | H1 | 5305-015-9582 | H101-0159582 | | 159582 | BOLT, MACHINE, cross-recess-pan-hd, S, cd- or zn-pltd, No. 8 (0.164)-32NC-2 x ⅜ | 2 | ea |
| 18-8 | H1 | 5305-016-1860 | H101-0161860 | | 161860 | SCREW, tapping cross-recess-pan-hd, gimlet-pt, sh-met-thd, S, cd- or zn-pltd, No. 8 (0.165) x ½ | 11 | ea |
| | | | | WO-691357 WO-691358 | | WINDSHIELD ASSY, w/o GLASS (M38A1) | 1 | ea |
| 18-1, 6 | | | G758-8332065 | WO-681406 | 8332065 | WINDSHIELD ASSY, w/o GLASS (M170) | 1 | ea |
| 18-2, 3, 7 | | | | WO-683937 | | WINDSHIELD, w/GLASS, complete, assy (M38A1) WINDSHIELD, w/GLASS, complete, assy (M170) | 1 1 | ea ea |

1805—FLOOR PANS AND ACCESS PANELS

| | | | | | | | | |
|-------|----|---------------|--------------|-------------|---------|---|----|----|
| | | 2520-769-7515 | G740-7697515 | WO-647574 | 7697515 | BOOT, gear shift lever | 1 | ea |
| | | 2520-769-7527 | G740-7697527 | WO-801058 | 7697527 | BOOT, transfer gear shift lever (ru) | 1 | ea |
| | | | | WO-685867 | | BRACKET, gas tank support front, assy (w/weld NUTS) (M170) | 1 | ea |
| | H1 | | H101-0271187 | | 271187 | NUT, hex, lt, ext-teeth lock washer, S, cd- or zn-pltd, $\frac{5}{16}$ -24NF-2B (bracket to center floor pan) | 3 | ea |
| | | | | WO-683909 | | BRACKET, gas tank support rear, assy (w/weld NUTS) | 1 | ea |
| | H1 | | H101-0271187 | | 271187 | NUT, hex, lt, ext-teeth lock washer, S, cd- or zn-pltd, $\frac{5}{16}$ -24NF-2B | 3 | ea |
| | | | | WO-680991 | 8677448 | BRACKET, No. 1, hold-down, body, left (used on vehicles through serial No. 60406) | 1 | ea |
| | | | | WO-680992 | | BRACKET, No. 1, hold-down, body, right (used on vehicles through serial No. 60406) | 1 | ea |
| | H6 | | H006-8330945 | | 8330945 | CLAMP, hose (Tinnerman), S, phos-ctd, $\frac{1}{2}$ ID | 1 | ea |
| | H6 | | H106-0111627 | | 111627 | CLAMP, hose, S, rustproof, 2 $\frac{1}{2}$ in. (lower) (gear shift lever boot) | 1 | ea |
| 18-16 | | 2510-769-7578 | G740-7697578 | WO-673474 | 7697578 | COVER, floor (access, transmission) | 1 | ea |
| 18-16 | H1 | 042-5899 | H101-0425899 | | 425899 | BOLT, ASSEMBLED WASHER, hex-hd, int-teeth-lock washer, header-pt, S, cd- or zn-pltd, $\frac{5}{16}$ -24UNC-2A x $\frac{1}{2}$ (supersedes REST 7375392 listed in subgroup 0312) (used on vehicles after serial No. 34021) | 1 | ea |
| | | | | | | BOLT, ASSEMBLED WASHER int-teeth lock washer, hex-hd, header-pt, S, cd- or zn-pltd, $\frac{1}{4}$ -20NC-2 x $\frac{5}{8}$ | 7 | ea |
| | | 2510-769-7520 | G740-7697520 | WO-674364 | 7697520 | COVER, front floor pan drain hole | 2 | ea |
| | | | | WO-674408 | 8677314 | COVER, front floor pan drain hole, w/GASKET, assy (superseded by COVER 8331954) | 2 | ea |
| 18-16 | | 5305-735-1314 | G740-7351314 | WO-675567 | 7351314 | SCREW, thumb, br, $\frac{1}{4}$ -20NC-2 x $\frac{5}{8}$ | 2 | ea |
| 18-16 | | | G758-8331954 | WO-682197 | 8331954 | COVER, front floor pan drain hole (supersedes COVER 8677314) | 2 | ea |
| 18-16 | | 2510-769-7522 | G740-7697522 | WO-674882 | 7697522 | COVER, inspection, floor, brake cylinder | 1 | ea |
| 18-16 | H1 | 042-5380 | H101-0425380 | | 425380 | BOLT, int-teeth, lock washer, hex-hd, header-pt, S, cd- or zn-pltd, $\frac{1}{4}$ -20NC-2 x $\frac{5}{8}$ | 4 | ea |
| 18-16 | | 2510-769-7525 | G740-7697525 | WO-674910 | 7697525 | COVER, w/weld NUTS (welded) (front floor pan, lower) | 1 | ea |
| 18-16 | H1 | 042-5380 | H101-0425380 | | 425380 | BOLT, int-teeth lock washer, hex-hd, header-pt, S, cd- or zn-pltd, $\frac{1}{4}$ -20NC-2 x $\frac{5}{8}$ | 11 | ea |
| | | 2510-769-7521 | G740-7697521 | WO-674365 | 7697521 | GASKET, floor, drain hole cover (ru) | 2 | ea |
| | H1 | 013-6603 | H101-0136603 | | 136603 | RIVET, split, oval-hd, S, $\frac{1}{8}$ x $\frac{1}{4}$ | 4 | ea |
| | | | | ONB-SN-2113 | 8676969 | NUT, weld, S, $\frac{1}{4}$ -20NC (front floor pan and dash panel (7), lower cover plate, front floor pan (14)) | 21 | ea |
| 18-16 | | | G758-8329735 | WO-672846 | 8329735 | NUT, S, $\frac{1}{4}$ -20NC w/RETAINER, (upper cover plate to dash panel (10), lower cover plate to front floor panel (13)) | 23 | ea |
| | | | | ONB-SN1610 | 8677317 | NUT, weld, S, No. 10-24NC (front floor pan and dash panel (13), gussets, left and right (2)) | 15 | ea |
| | | | | WO-674898 | | | | |

| (1) ILLUSTRATION NO. | (2) REFER- ENCE SYMBOLS | (3) FEDERAL STOCK NO. | (4) ORDNANCE STOCK NO. | (5) MFR'S PART NO. | (6) ORDNANCE PART NO. | (7) DESCRIPTION | (8) QUANTITY INCOR- PORATED IN UNIT | (9) UNIT OF ISSUE |
|---|----------------------------------|-----------------------------|------------------------------|-----------------------|-----------------------------|--|---|----------------------------|
| GROUP 18--BODY--Continued | | | | | | | | |
| 1805--FLOOR PANS AND ACCESS PANELS | | | | | | | | |
| --Continued | | | | | | | | |
| | | | | WO-680445 | | NUT, weld, S, $\frac{5}{16}$ -18NC (front floor pan and dash panel (9), rear floor pan (1)) | 10 | ea |
| | | | | WO-674939 | | NUT, weld, S, $\frac{5}{16}$ -24NF (upper cover plate, front floor pan) | 1 | ea |
| | | | | WO-684117 | | PAN, center floor, complete, assy (welded) (M170) | 1 | ea |
| | | | | WO-680631 | | PAN, floor, w/weld NUTS (welded) | 1 | ea |
| | | | | WO-684248 | | PAN, floor, w/weld NUTS (welded) (M170) | 1 | ea |
| | | | | WO-680624 | | PAN, front floor, w/weld NUTS (welded) | 1 | ea |
| | | | | WO-684004 | | PAN, front floor, w/weld NUTS (welded) (M170) | 1 | ea |
| | | | | WO-680003 | 8677608 | PAN, rear floor (welded) | 1 | ea |
| | | | | WO-684192 | | PAN, rear floor (welded) (M170) | 1 | ea |
| | | | | WO-680625 | 8677630 | PAN, rear floor w/PAN, cross SILL, RISER, and weld NUT (welded) | 1 | ea |
| | | | | WO-684246 | | PAN, rear floor, w/HOUSE and rear PANELS, assy (welded) (M170) | 1 | ea |
| 18-16 | | | | WO-680159 | 8677606 | PANEL, front floor, w/DASH (welded) | 1 | ea |
| | | | | WO-683009 | | PANEL, front floor, w/DASH (welded) (M170) | 1 | ea |
| | | | | WO-685257 | | PLATE, access, gas tank unit (M170) | 1 | ea |
| | H1 | 042-5379 | H101-0425379 | | 425379 | BOLT, integral lock washer, int-teeth, hex-hd, header-pt, S, cd- or zn-pltd, $\frac{1}{4}$ -20NC-2 x $\frac{1}{2}$ | 7 | ea |
| 18-16 | | 2540-769-7523 | G740-7697523 | WO-674884 | 7697523 | PLATE, access, motor heater cutout | 1 | ea |
| 18-16 | H1 | 042-5380 | H101-0425380 | | 425380 | BOLT, ASSEMBLED WASHER, int-teeth lock washer, hex-hd, header-pt, S, cd- or zn-pltd, $\frac{1}{4}$ -20NC-2 x $\frac{5}{8}$ | 5 | ea |
| | | 2530-769-7526 | G740-7697526 | WO-674919 | 7697526 | PLATE, access, steering column (superseded by PLATE WO-685679) | 1 | ea |
| 18-16 | H1 | 042-5380 | H101-0425380 | | 425380 | BOLT, ASSEMBLED WASHER, int-teeth lock washer, hex-hd, header-pt, S, cd- or zn-pltd, $\frac{1}{4}$ -20NC-2 x $\frac{5}{8}$ | 2 | ea |
| 18-16 | | | | WO-685679 | | PLATE, access, steering column (supersedes PLATE 7697526) | 1 | ea |
| 18-16 | | 2520-769-7519 | G740-7697519 | WO-674316 | 7697519 | PLATE, access, transfer case bolt | 1 | ea |
| 18-16 | H1 | 042-5380 | H101-0425380 | | 425380 | BOLT, ASSEMBLED WASHER int-teeth lock washer, hex-hd, header-pt, S, cd- or zn-pltd, $\frac{1}{4}$ -20NC-2 x $\frac{5}{8}$ | 2 | ea |
| | | 2510-737-5170 | G740-7375170 | WO-674953 | 7375170 | PLATE, catch, tool box lid | 1 | ea |
| 18-16 | | 2510-737-5158 | G740-7375158 | WO-673483 | 7375158 | PLATE, cover, power-take-off shift | 1 | ea |

| | | | | | | | | |
|-------|----|---------------|--------------|-----------------------|---------|--|----|----|
| 18-16 | H1 | 5305-016-1895 | H101-0161895 | | 161895 | SCREW, tapping, cross-recess, pan-hd, gimlet-pt, sheet-thd, S, cd- or zn-pltd, No. 10 (0.191) x 1/2 | 4 | ea |
| | | 2510-769-7579 | G740-7697579 | WO-673481 | 7697579 | PLATE, cover, toe board (used on vehicles through serial No. 71065) | 2 | ea |
| | H1 | 042-5380 | H101-0425380 | | 425380 | BOLT, ASSEMBLED WASHER, int-teeth lock washer, hex-hd, header-pt, S, cd- or zn-pltd, 1/4-20NC-2 x 5/8 | 4 | ea |
| | | | G758-8329733 | WO-680509 | 8329733 | PLATE, cover, w/weld NUTS (welded) (front floor pan, upper) (superseded by PLATE WO-680506) | 1 | ea |
| 18-16 | H1 | 042-5380 | H101-0425380 | | 425380 | BOLT, ASSEMBLED WASHER, int-teeth lock washer, hex-hd, header-pt, S, cd- or zn-pltd, 1/4-20NC-2 x 5/8 | 11 | ea |
| 18-16 | | | | WO-680506 | | PLATE, cover (front floor pan, upper) (supersedes PLATE 8329733) | 1 | ea |
| 18-16 | | 5340-769-7581 | G740-7697581 | WO-674230 | 7697581 | PLUG, button, ru, 3/4 in (drain, front floor pan) | 1 | ea |
| | | 2520-769-7577 | G740-7697577 | WO-801568 | 7697577 | RING, gear shift lever housing cover | 1 | ea |
| | H1 | 5305-016-1895 | H101-0161895 | | 161895 | SCREW, tapping, pan-hd, cross-recess, gimlet-pt, sheet metal thread, S, cd- or zn-pltd, No. 10 (0.191) x 1/2 | 4 | ea |
| | | | | WO-680399 | | RISER, front to rear floor | 1 | ea |
| | H1 | 5320-010-4080 | H001-0924139 | | 104080 | RIVET, b-hd, S, 1/4 x 3/8 (No. 1 body hold-down bracket, left and right) | 2 | ea |
| | | 5330-734-8567 | G740-7348567 | PEE-577.2 WO-94096 | 7348567 | SEAL (WEATHERSTRIP), soft, pliable compound, 3/16 dia, 80 ft | † | ea |
| | | | | WO-674743 | | SILL, cross, rear floor pan, rear, assy (superseded by SILL WO-691593 for M38A1 only) | 1 | ea |
| | | | | WO-691593 | | SILL, cross, rear floor pan, rear, assy (supersedes SILL WO-674743) | 1 | ea |
| | | | | WO-681167 | 8677588 | WELL, gas tank, front floor, pan-shaped | 1 | ea |
| | | | | | | 1806—SEATS, CRASH PADS, TRIM, AND UPHOLSTERY | | |
| | | | | WO-685513 | | BACK, assy (driver's seat) (supersedes BACK WO-691550) (M170) | 1 | ea |
| | | | | WO-685387 | | Composed of: | | |
| | | | | WO-685521 | | 1 PAD | | |
| | | | | WO-685507 | | 1 SPRING | | |
| | | | | WO-691550 | | 1 TRIM | | |
| 18-13 | | | | | | BACK, assy (driver's seat) (supersedes BACK WO-685513) (M170) | 1 | ea |
| | | | | | | Composed of: | | |
| | | | | WO-691537 | | 1 PAD | | |
| | | | | WO-691540 | | 1 PAD | | |
| | | | | WO-300159 | | 1 RING | | |
| | | | | WO-685521 | | 1 SPRING | | |
| | | | | WO-685507 | | 1 TRIM | | |

| (1) ILLUSTRATION NO. | (2) REFER- ENCE SYMBOLS | (3) FEDERAL STOCK NO. | (4) ORDNANCE STOCK NO. | (5) MFR'S PART NO. | (6) ORDNANCE PART NO. | (7) DESCRIPTION | (8) QUANTITY INCOR- PORATED IN UNIT | (9) UNIT OF ISSUE |
|---|----------------------------------|-----------------------------|------------------------------|-----------------------|-----------------------------|--|---|----------------------------|
| GROUP 18—BODY—Continued | | | | | | | | |
| 1806—SEATS, CRASH PADS, TRIM, AND UPHOLSTERY—Continued | | | | | | | | |
| 18-12 | | | | WO-685517 | | BACK, front passenger seat, assy (complete w/TRIM) (superseded by BACK WO-691553) (M170) | 1 | ea |
| | | | | WO-691553 | | BACK, front passenger seat assy (complete w/TRIM) (supersedes BACK WO-685517) (M170) | 1 | ea |
| | H1 | 011-8073 | H001-0926281 | WO-685149 | | BRACE, front passenger seat back frame (M170) | 1 | ea |
| | H1 | 5310-012-0394 | H001-7043741 | | 118073 | RIVET, solid, fl-hd, S, $\frac{3}{8}$ x $\frac{15}{16}$ | 2 | ea |
| | | | | | 120394 | WASHER, FLAT, light series, S, cd- or zn-pltd, $\frac{13}{32}$ ID, $\frac{13}{16}$ OD, 0.065 thk (brace to front passenger seat back) | 4 | ea |
| | | | | WO-685286 | | BRACKET, locking, front passenger seat frame (M170) | 1 | ea |
| | | | | WO-664595 | | BRACKET, pivot, front passenger seat (M170) | 1 | ea |
| 18-12, 13 | H1 | | H101-0451975 | | 451975 | BOLT, mach, hex-hd, w/spring lock washer, S, cd- or zn-pltd, $\frac{5}{16}$ -18NC x $\frac{3}{4}$ (seat pivot bracket to center floor pan) | 2 | ea |
| | H1 | 011-8073 | H001-0926281 | | 118073 | RIVET, solid, fl-hd, S, $\frac{3}{8}$ x $\frac{15}{16}$ (front passenger seat back frame to front passenger seat pivot bracket) | 2 | ea |
| | H1 | 5310-012-0394 | H001-7043741 | | 120394 | WASHER, FLAT, light series, S, cd- or zn-pltd, $\frac{13}{32}$ ID, $\frac{13}{16}$ OD, 0.065 thk (front passenger seat back frame to front passenger seat pivot bracket) | 2 | ea |
| 18-12 | H1 | 5310-044-6363 | H101-0446363 | | 446363 | WASHER, FLAT, S, cd- or zn-pltd, $\frac{3}{8}$ ID, $\frac{1}{8}$ OD, 0.083 thk (seat pivot bracket to center floor pan) | 2 | ea |
| 18-9 | | | G758-8328486 | WO-681161 | 8328486 | BRACKET, retaining, seat (rear passenger) (M38A1) | 2 | ea |
| | | 5305-737-2885 | G740-7372885 | WO-673600 | 7372885 | SCREW, int-teeth lock washer, hex-hd, S, cd- or zn- pltd, $\frac{1}{4}$ -20NC-2 x $\frac{5}{8}$ (superseded by SCREW 425380) | 4 | ea |
| 18-9 | H1 | | H101-0425380 | | 425380 | SCREW, int-teeth-lock washer, hex-hd, header-pt, S, cd- or zn-pltd, $\frac{1}{4}$ -20NC-2 x $\frac{5}{8}$ (supersedes SCREW 7372885) | 4 | ea |
| | | | | WO-684185 | | BRACKET, retainer spring, front seat frame (use after vehicles serial No. 61809) (M38A1) | 1 | ea |
| | | | | WO-673775 | | CHAIN, retaining (seat hinge pivot) (M38A1) | 1 | ea |
| | | 4030-737-5007 | G740-7375007 | WO-674418 | 7375007 | CHAIN, retn, seat hinge pivot, w/RING and PIN, assy (M38A1) | 2 | ea |
| | | | | WO-673775 | | Composed of: 1 CHAIN | | |
| | | | | | 8676970 | 1 PIN | | |
| | | | | WO-673774 | | 2 RING | | |

| | | | | | | | | |
|-----------|----|---------------|--------------|------------|---------|---|---|----|
| 18-10, 11 | H2 | | H002-7697531 | | 7697531 | CLIP, seat cushion spring, hog, $1\frac{1}{16}$ -14 ga | † | ea |
| | | | | WO-685514 | | COVER, crash pad (driver's seat frame) (M170) | 1 | ea |
| | | | | WO-685500 | | CUSHION, front driver's seat, assy (complete) (super- seded by CUSHION WO-691549) (M170) | 1 | ea |
| | | | | WO-687079 | | CUSHION, front passenger seat, assy (complete) (super- seded by CUSHION WO-691549) (M170) | 1 | ea |
| 18-12, 13 | | | | WO-691549 | | CUSHION, front passenger and driver's seat, assy (part of CUSHION WO-691550) (supersedes CUSHION WO-685500 and WO-687079) | 2 | ea |
| | | | | | | Composed of: | | |
| | | | | WO-685501 | | 1 COVER | | |
| | | | | WO-691539 | | 1 PAD | | |
| | | | | WO-691541 | | 1 PAD | | |
| | | | | WO-687255 | | 1 PAN | | |
| | | | | WO-K300159 | | 1 RING | | |
| | | | | WO-685449 | | 1 SPRING | | |
| | | | | WO-685525 | | CUSHION, front passenger, assy (complete w/TRIM and FRAME) (superseded by CUSHION WO-691552) (M170) | 1 | ea |
| 18-2, 3 | | | | WO-691552 | | CUSHION, front passenger, assy (complete w/TRIM and FRAME) (supersedes CUSHION WO-685525) (M170) | 1 | ea |
| 18-10, 11 | | 2540-737-5008 | G740-7375008 | WO-672000 | 7375008 | CUSHION, driver's and front passenger seat, assy (M38A1) | 2 | ea |
| 18-10, 11 | H1 | | H101-0455305 | | 455305 | BOLT, MACHINE, assembled washer, hex-hd, split lock washer, header-pt, S, cd- or zn-pltd, $\frac{3}{16}$ -24UNF- 2A x $\frac{5}{8}$ | 4 | ea |
| 18-10, 11 | | | | WO-NPN* | | CUSHION, driver's and front passenger seat back, assy (part of SEAT, 8328489) (built-up on SEAT frame 8328487 at assy) (M38A1) | 2 | ea |
| | | | | | 7697531 | Composed of: | | |
| | | | | WO-671963 | | † CLIP | | |
| | | | | | 111687 | 1 PAD | | |
| | | | | | 7697537 | 24 SCREW | | |
| | | | | WO-672012 | | 1 SPRING | | |
| | | | | | | 1 TRIM | | |
| | | | | | 140241 | 24 WASHER | | |
| 18-9 | | 2540-769-7499 | G740-7697499 | WO-673586 | 7697499 | CUSHION, rear seat, assy (M38A1) | 1 | ea |
| 18-11 | | | G758-8328487 | WO-680257 | 8328487 | FRAME, driver's seat (welded) (M38A1) | 1 | ea |
| 18-11 | H1 | | H101-0451975 | | 451975 | SCREW, lock washer, sltd-hex-hd, S, cd- or zn-pltd, $\frac{3}{16}$ -18NC-3 x $\frac{3}{4}$ | 2 | ea |
| 18-11 | H1 | 5310-012-0393 | H001-7043711 | | 120393 | WASHER, FLAT, S, cd- or zn-pltd, $1\frac{1}{32}$ ID, $1\frac{1}{16}$ OD, 0.065 thk | 2 | ea |
| 18-13 | | | | WO-684250 | | FRAME, driver's seat (welded) (M170) | 1 | ea |
| 18-10 | | 2510-769-7505 | G740-7697505 | WO-673511 | 7697505 | FRAME, front passenger seat (welded) (M38A1) | 1 | ea |
| 18-12 | | | | WO-685154 | | FRAME, front passenger seat (welded) | 1 | ea |

| (1) | (2) | (3) | (4) | (5) | (6) | (7) | (8) | (9) |
|---|-------------------|---------------------------|------------------------------|----------------|-------------------|--|-------------------------------|---------------|
| ILLUSTRATION NO. | REFERENCE SYMBOLS | FEDERAL STOCK NO. | ORDNANCE STOCK NO. | MFR'S PART NO. | ORDNANCE PART NO. | DESCRIPTION | QUANTITY INCORPORATED IN UNIT | UNIT OF ISSUE |
| GROUP 18—BODY—Continued | | | | | | | | |
| 1806—SEATS, CRASH PADS, TRIM, AND UPHOLSTERY—Continued | | | | | | | | |
| 18-12 | | | | WO-685158 | | FRAME, front passenger seat cushion (welded) (M170)..... | 1 | ea |
| 18-9 | | | | WO-673408 | 8673489 | FRAME, rear seat, assy (M38A1)..... | 1 | ea |
| | | | | WO-673387 | 7697502 | FRAME, rear seat, back (M38A1)..... | 1 | ea |
| | H1 | 2510-769-7502 010-4111 | G740-7697502 H001-0924288 | | 104111 | RIVET, b-hd, S, $\frac{3}{8}$ x $\frac{3}{4}$ | 2 | ea |
| | | 2510-769-7501 | G740-7697501 | WO-673371 | 7697501 | FRAME, rear seat, bottom half (M38A1)..... | 1 | ea |
| 18-10, 11 | H2 | | H002-0103277 | | 549189 | GROMMET, w/WASHER, plain, br, black, No. 4 ($\frac{1}{2}$ in) (front passenger seat back) (front driver's seat back) | 2 | ea |
| | H2 | | H102-0120041 | | 120041 | GROMMET, plain, br, black, No. 4, $\frac{1}{2}$ in. (front passenger seat back) (front driver's seat back) | 2 | ea |
| | | | | WO-681207 | | LEG, driver's seat, left rear (welded to frame) (M38A1)..... | 1 | ea |
| 18-11 | H1 | | H101-9409097 | | 9409097 | BOLT, MACHINE, assembled washer, hex-hd, split lock washer, header-pt, S, cd- or zn-pltd, $\frac{5}{8}$ -18UNC-2A x $\frac{5}{8}$ (attaches seat leg to wheel housing) | 1 | ea |
| | | | | WO-681206 | | LEG, driver's seat, right rear (welded to frame) (M38A1)..... | 1 | ea |
| 18-11 | H1 | | H101-9409097 | | 9409097 | BOLT, MACHINE, assembled washer, hex-hd, split lock washer, header-pt, S, cd- or zn-pltd, $\frac{5}{16}$ -18UNC-2A x $\frac{5}{8}$ (seat leg to floor) | 1 | ea |
| | | | | WO-684249 | | LEG, rear, front driver's seat, (welded to frame) (M170)..... | 1 | ea |
| | | | | WO-685262 | | LEG, front driver's seat (welded to frame) (M170)..... | 1 | ea |
| 18-12 | H2 | | G758-8328488 H002-7697591 | WO-681189 | 8328488 | LEG, front passenger seat (welded) (M38A1)..... | 1 | ea |
| | | | | WO-664933 | 7697591 | LOOP, footman (footman loop to front passenger seat cushion pan) (M170) | 1 | ea |
| | | | | WO-664934 | | NUT, clip, No. 10-A thd (optional w/NUT, WO-664934) | 2 | ea |
| | | | | WO-664934 | | NUT, speed, No. 10-A thd (optional w/NUT, WO-664933) | 2 | ea |
| 18-12 | | | | | 162457 | SCREW, tapping, oval-hd, cross-recess, cd- or zn-pltd, No. 10-12 x $\frac{5}{8}$ | 2 | ea |
| | | | | WO-685369 | | PAD, crash (driver's seat frame) (superseded by PAD WO-691394) (M170) | 1 | ea |
| | | | | WO-691394 | | PAD, crash (driver's seat frame) (supersedes PAD WO-685369) (M170) | 1 | ea |
| | | | | WO-685143 | | PAD, crash (front passenger seat frame) (superseded by PAD WO-691395) (M170) | 1 | ea |
| | | | | WO-691395 | | PAD, crash (front passenger seat frame) (supersedes PAD WO-685143) (M170) | 1 | ea |

| | | | | | | |
|-----------|-----------|-----------|---|--|----|----|
| 18-10, 11 | | WO-671963 | | PAD, driver's and front passenger seat back (M38A1)..... | 2 | ea |
| | | WO-671962 | 8677256 | PAD, driver's and passenger seat cushion spring (M38A1)... | 2 | ea |
| | | WO-673504 | 8673988 | PAD, rear seat cushion spring (M38A1)..... | 1 | ea |
| | | WO-685384 | | PAD, seat back (front passenger) (rubberized steel padding) (superseded by PAD WO-691393) (M170) | 1 | ea |
| | | WO-691393 | | PAD, seat back (front passenger) (Tapatco) (supersedes PAD WO-685384) (M170) | 1 | ea |
| 18-13 | | WO-685387 | | PAD, seat back spring (driver's and front passenger) (superseded by PAD WO-691540) (M170) | 2 | ea |
| | | WO-691540 | | PAD, seat back spring (Tapatco) (driver's and front passenger) (supersedes PAD WO-685387) (M170) | 2 | ea |
| | | WO-691537 | | PAD, seat back spring, assy (Corofelt) (driver's) (M170) | 1 | ea |
| | | WO-685386 | | PAD, seat cushion spring (driver's and front passenger) (superseded by PAD WO-691541) (M170) | 2 | ea |
| | | WO-691541 | | PAD, seat cushion spring (front passenger and driver's seat) (Tapatco) (supersedes PAD WO-685386) (M170) | 2 | ea |
| | | WO-691539 | | PAD, seat cushion spring, assy (driver's and front passenger) (M170) | 2 | ea |
| | | WO-685567 | | PAD w/COVER, assy (driver's seat frame) (superseded by PAD WO-691547) (M170) | 1 | ea |
| | | WO-685514 | | Composed of: | | |
| | | WO-685369 | | 1 COVER | | |
| | | WO-691547 | | 1 PAD | | |
| | | | | PAD w/COVER, assy (driver's seat frame) (supersedes PAD WO-685567) (M170) | 1 | ea |
| | | | | Composed of: | | |
| | | WO-685514 | | 1 COVER | | |
| | | WO-691394 | | 1 PAD | | |
| | | WO-685568 | | PAD, w/COVER, assy (front passenger seat) (superseded by PAD WO-691546) (M170) | 1 | ea |
| | | | Composed of: | | | |
| | WO-685518 | | 1 COVER | | | |
| | WO-685384 | | 1 PAD | | | |
| | WO-691546 | | PAD, w/COVER, assy (front passenger seat) (supersedes PAD WO-685568) (M170) | 1 | ea | |
| | | | Composed of: | | | |
| | WO-685518 | | 1 COVER | | | |
| | WO-691393 | | 1 PAD | | | |
| | WO-685566 | | PAD w/COVER, assy (front passenger seat frame) (superseded by PAD WO-691545) (M170) | 1 | ea | |
| 18-12 | | WO-691545 | | PAD w/COVER, assy (front passenger seat frame) (supersedes PAD WO-685566) (M170) | 1 | ea |
| | | WO-685522 | | Composed of: | | |
| | | WO-691395 | | 1 COVER | | |
| | | | 1 PAD | | | |

| (1) | (2) | (3) | (4) | (5) | (6) | (7) | (8) | (9) |
|------------------|-------------------|-------------------|--------------------|----------------|-------------------|--|-------------------------------|---------------|
| ILLUSTRATION NO. | REFERENCE SYMBOLS | FEDERAL STOCK NO. | ORDNANCE STOCK NO. | MFR'S PART NO. | ORDNANCE PART NO. | DESCRIPTION | QUANTITY INCORPORATED IN UNIT | UNIT OF ISSUE |
| | | | | | | GROUP 18—BODY—Continued | | |
| | | | | | | 1806—SEATS, CRASH PADS, TRIM, AND UPHOLSTERY—Continued | | |
| | | | | WO-685569 | | PAN, driver's seat back (M170)..... | 1 | ea |
| | | | | WO-664933 | | NUT, clip, No. 10-A thd (optional w/NUT WO-664934) | 4 | ea |
| | | | | WO-664934 | | NUT, speed, No. 10-A-thd (optional w/NUT WO-664933) | 4 | ea |
| | | | | | 162487 | SCREW, tapping, cross-recess, oval-hd, S, cd- or zn-pltd, No. 10-12 x 1 1/2 (driver's seat back pan to seat frame) | 4 | ea |
| | | | | WO-685290 | | PAN, driver's seat, crash pad seat back (M170)..... | 1 | ea |
| | | | | WO-673557 | | PAN, driver's and front passenger seat (includes weld NUTS and CLIPS) (welded) (M38A1) | 2 | ea |
| | | | | WO-687255 | | PAN, driver's seat, front passenger seat (welded) (includes seat cushion spring RETAINER) (M170) | 2 | ea |
| | | | | WO-664933 | | NUT, clip, No. 10-A thd (optional w/NUT WO-664934) | 4 | ea |
| | | | | WO-664934 | | NUT, speed, No. 10-A thd (optional w/NUT WO-664933) | 4 | ea |
| | | | | | 162487 | SCREW, tapping, cross-recess-oval-hd, S, cd- or zn-pltd, No. 10 (0.190) x 1 1/2 (cushion pan to frame) | 4 | ea |
| | | | | WO-670372 | | PANEL, front seat back (driver's seat (1), passenger seat (1)) (M38A1) | 2 | ea |
| | | | | | 443120 | PIN, grooved, S, cd- or zn-pltd, 1/2 x 3/32 (front passenger seat frame) (M170) | 1 | ea |
| | | | | WO-685285 | | PIN, locking, front passenger seat frame (M170)..... | 1 | ea |
| | | 5315-737-6905 | G740-7376905 | WO-677836 | 7376905 | PIN, 1 3/32 x 5/16 (pivot, front passenger seat)..... | 2 | ea |
| | | | | WO-674427 | 8676970 | PIN, retaining chain (seat hinge pivot) (M38A1)..... | 1 | ea |
| 18-12, 13 | | 2510-769-7506 | G740-7697506 | WO-673561 | 7697506 | PIVOT, front seat hinge, left (driver's seat (1), passenger's seat (2) for M170, passenger seat (1) M38A1) | 3 | ea |
| | | | | | | M170 | 1 | ea |
| | | | | | | M38A1 | 1 | ea |
| 18-12 | H1 | | H101-0271187 | | 271187 | NUT, hex, lt, ext-teeth-lock washer, S, cd- or zn-pltd, 5/16-24NF-2B | 2 | ea |
| 18-12 | H1 | 012-0213 | H001-5419841 | | 120213 | SCREW, cap, hex-hd, S, cd- or zn-pltd, 5/16-24NF-3 x 7/8 | 2 | ea |
| 18-10 | | | G740-7697508 | WO-674425 | 7697508 | PIVOT, front seat hinge, left, w/CHAIN, assy (M38A1) | 1 | ea |
| 18-13 | | 2510-769-7507 | G740-7697507 | WO-673562 | 7697507 | PIVOT, front seat hinge, right (driver's seat (1) M170, passenger seat (1) (M38A1) | 1 | ea |
| 18-10 | | 2520-737-2670 | G740-7372670 | WO-674426 | 7372670 | PIVOT, front seat hinge, right, w/CHAIN, assy (M38A1) | 1 | ea |

| | | | | | | | | |
|-------------|----|---------------|--------------|------------------------|---------|--|---|----|
| 18-10 | H1 | | H101-9409898 | | 9409098 | BOLT, MACHINE, assembled washer, hex-hd, split lock washer, header-pt, S, cd- or zn-pltd, $\frac{5}{16}$ -18UNC-2A x $\frac{7}{8}$ (front passenger seat pivot to floor) | 2 | ea |
| | | | | | | | 2 | ea |
| 18-10 | H1 | 012-0376 | H001-4167541 | | 120376 | NUT, hex, lt, s-fin, S, cd- or zn-pltd, $\frac{5}{16}$ -18NC-2 | 2 | ea |
| 18-10 | H1 | 5310-012-0393 | H001-7043711 | | 120393 | WASHER, FLAT, S, cd- or zn-pltd, $\frac{11}{32}$ ID, $\frac{11}{16}$ OD, 0.065 thk | 2 | ea |
| | | | | UC-51210 WO-675137 | | PLUG, button, S, zn-pltd, 0.965 to 0.980 dia (driver's seat frame (M38A1)) | 2 | ea |
| 18-9 | | 2510-769-7509 | G740-7697509 | WO-673593 | 7697509 | RETAINER, rear seat frame spring (M38A1) | 2 | ea |
| 18-9 | H1 | 042-5379 | H101-0425379 | | 425379 | BOLT, int-teeth lock washer, hex-hd, header-pt, S, cd- or zn-pltd, $\frac{1}{4}$ -20NC-2 x $\frac{1}{2}$ | 4 | ea |
| 18-9 | | 2510-769-7510 | G740-7697510 | WO-673577 | 7697510 | RETAINER, rear seat pivot tube (M38A1) | 2 | ea |
| 18-9 | H1 | 042-5379 | H101-0425379 | | 425379 | BOLT, int-teeth lock washer, hex-hd, header-pt, S, cd- or zn-pltd, $\frac{1}{4}$ -20NC-2 x $\frac{1}{2}$ | 2 | ea |
| | | | | WO-673774 WO-685506 | | RING, retn chain (seat hinge pivot) (M38A1) | 2 | ea |
| | | | | | | SEAT, driver's assy (complete w/TRIM) (superseded by SEAT WO-691551) (M170) | 1 | ea |
| 18-2, 3 | | | | WO-691551 | | SEAT, driver's, assy (complete w/TRIM) (supersedes SEAT WO-685506) (M170) | 1 | ea |
| 18-1, 4, 11 | | | G758-8328489 | WO-680156 | 8328489 | SEAT, driver's, assy (complete w/TRIM) (M38A1) | 1 | ea |
| 18-1, 4, 10 | | 2510-769-7534 | G740-7697534 | WO-673579 | 7697534 | SEAT, front passenger, assy (complete w/TRIM) (M38A1) | 1 | ea |
| 18-1, 4, 9 | | 2510-769-7535 | G740-7697535 | WO-673580 | 7697535 | SEAT, rear, assy (complete w/TRIM) (M38A1) | 1 | ea |
| 18-9 | | 5340-769-7538 | G740-7697538 | WO-673497 | 7697538 | SPRING, coil, rear seat back, assy (M38A1) | 1 | ea |
| | | 5340-769-7539 | G740-7697539 | WO-673498 | 7697539 | SPRING, coil, rear seat cushion, assy (M38A1) | 1 | ea |
| 18-10, 11 | | 5340-769-7537 | G740-7697537 | WO-671961 | 7697537 | SPRING, coil, seat back, assy (driver's (1), front passenger (1)) (M38A1) | 2 | ea |
| | | 5340-769-7536 | G740-7697536 | WO-671960 | 7697536 | SPRING, coil, seat cushion, assy (driver's (1), front passenger (1)) (superseded by SPRING, WO-685467) (M38A1) | 2 | ea |
| | | | | WO-685467 | | SPRING, coil, seat cushion, assy (driver's (1), front passenger (1)) (supersedes SPRING 7697536) (M38A1) | 2 | ea |
| | | | | WO-685449 WO-687869 | | SPRING, driver's and passenger seat, assy (M170) | 2 | ea |
| | | | | | | SPRING, driver's seat back, assy (coil type) (optional SPRING WO-685521) (M170) | 1 | ea |
| | | | G758-8332513 | WO-684184 | 8332513 | SPRING, retaining, front passenger seat (used on vehicles after serial No. 61809) (M38A1) | 1 | ea |
| | H1 | 012-0375 | H001-4167501 | | 120375 | NUT, hex, lt, s-fin, S, cd- or zn-pltd, $\frac{1}{4}$ -20NC-2 | 2 | ea |
| | | 5305-737-2885 | G740-7372885 | WO-673600 | 7372885 | SCREW, int-teeth-lock washer, hex-hd, header-pt, S, cd- or zn-pltd, $\frac{1}{4}$ -20NC-2 x $\frac{5}{8}$ (superseded by SCREW 425380) | 2 | ea |
| | H1 | | H101-0425380 | | 425380 | SCREW, int-teeth-lock washer, hex-hd, header-pt, S, cd- or zn-pltd, $\frac{1}{4}$ -20NC-2 x $\frac{5}{8}$ (supersedes SCREW 7372885) | 2 | ea |
| 18-13 | | | | WO-685521 | | SPRING, seat back, assy (coil type, driver's) (optional w/SPRING WO-687869) (M170) | 1 | ea |
| 18-12 | | | | WO-685789 | | STRAP, upper litter rack stowage (M170) | 2 | ea |

| (1) ILLUSTRATION NO. | (2) REFERENCE SYMBOLS | (3) FEDERAL STOCK NO. | (4) ORDNANCE STOCK NO. | (5) MFR'S PART NO. | (6) ORDNANCE PART NO. | (7) DESCRIPTION | (8) QUANTITY INCORPORATED IN UNIT | (9) UNIT OF ISSUE |
|---|--------------------------|--------------------------|---------------------------|-----------------------|--------------------------|--|--------------------------------------|----------------------|
| GROUP 18—BODY—Continued | | | | | | | | |
| 1806—SEATS, CRASH PADS, TRIM, AND UPHOLSTERY—Continued | | | | | | | | |
| 18-9 | | | | WO-684177 | | SUPPORT, front, auxiliary litter, inner (M170) | 1 | ea |
| 18-9 | H1 | 5305-011-1687 | H101-0111687 | WO-673581 | 111687 | TRIM, rear seat back, assy (M38A1) | 1 | ea |
| 18-9 | H1 | 5310-014-0241 | H101-0140241 | | 140241 | SCREW, tapping, oval-hd, gimlet-pt, sh-met-thd, S, cd- or zn-pltd, No. 10 (0.191) x 1/2 | 10 | ea |
| | | | | WO-673587 | | WASHER, FINISHING, S, cd- or zn-pltd, No. 10 (0.190) | 10 | ea |
| | H1 | 5305-011-1687 | H101-0111687 | | 111687 | TRIM, rear seat cushion, assy (M38A1) | 1 | ea |
| | H1 | 5310-014-0241 | H101-0140241 | | 140241 | SCREW, tapping, oval-hd, gimlet-pt, sh-met-thd, S, cd- or zn-pltd, No. 10 (0.191) x 1/2 in. | 10 | ea |
| 18-10, 11 | | | | WO-672012 | | WASHER, FINISHING, S, cd- or zn-pltd, No. 10 (0.190) | 10 | ea |
| 18-10, 11 | H1 | 5305-011-1687 | H101-0111687 | | 111687 | TRIM, seat back, assy (driver's (1), front passenger (1)) (M38A1) | 2 | ea |
| 18-10, 11 | H1 | 5310-014-0241 | H101-0140241 | | 140241 | SCREW, tapping, oval-hd, gimlet-pt, sh-met-thd, S, cd- or zn-pltd, No. 10 (0.191) x 1/2 | 24 | ea |
| 18-13 | | | | WO-685507 | | WASHER, FINISHING, S, cd- or zn-pltd, No. 10 (0.190) | 24 | ea |
| 18-12, 13 | H1 | 011-1687 | H101-0111687 | | 111687 | TRIM, seat back, assy (driver's (1), front passenger (1)) (M170) | 2 | ea |
| 18-12, 13 | H1 | 5310-014-0241 | H101-0140241 | | 140241 | SCREW, TAPPING, OVAL-HD, gimlet-pt, sh-met-thd, S, cd- or zn-pltd, No. 10 (0.191) x 1/2 | 22 | ea |
| | | | | WO-672016 | | WASHER, FINISHING, S, cd- or zn-pltd, No. 10 (0.190) | 22 | ea |
| | H2 | | H102-0120044 | | 120044 | TRIM, seat cushion, assy (driver's (1), front passenger (1)) (M38A1) | 2 | ea |
| | H1 | 012-0394 | H001-7043741 | | 120394 | WASHER, FLAT, br, black, No. 4, 1/2 (front passenger seat back) (front driver's seat back) | 2 | ea |
| | | | | | | WASHER, FLAT, S, cd- or zn-pltd, 1 3/8 ID, 1 3/16 OD, 0.065 thk (used as hinge bearing on rear seat) | 2 | ea |
| 1808—STOWAGE AND STRAPS | | | | | | | | |
| | | | | WO-674086 | | BODY, spare gas can bracket | 1 | ea |
| | | | | ONB-SK3851C | | BOSS, weld, flanged (tool box) (used on vehicles through serial No. 29213) | 1 | ea |
| | | | | WO-675071 | | | | |
| | | | | WO-680404 | 8677601 | BOX, glove, side and bottom, assy | 1 | ea |

| | | | | | | | | | |
|-------|----|---------------|---------------|------------------------------|------------------------|---|--|----|----|
| 18-4 | H1 | | H101-0454783 | | 454783 | SCREW, assembled washer, cross-recess-pan-hd, int-teeth lock washer, header-pt, S, cd- or zn-pltd, No. 10 (0.190)-24NC-2A x 1/2 | 9 | ea | |
| | | | | WO-683107 | | BRACKET, guide, tool box lid catch (used on vehicles after serial No. 29213) | 1 | ea | |
| | | | | WO-681266 | 8677401 | BRACKET, shovel stowage, w/weld NUTS and footman LOOP, assy | 1 | ea | |
| | | | G740-7375163 | WO-673457 | 7375163 | BRACKET, spare gasoline can, assy | 1 | ea | |
| | | | H101-0455319 | | 455319 | BOLT, assembled washer, hex-hd, split lock washer, header-pt, S, cd- or zn-pltd, 3/8-16UNC-2A x 2 1/8 | 4 | ea | |
| | | H1 | 012-0377 | H001-4167581 | | 120377 | NUT, hex, lt, s-fin, S, cd- or zn-pltd 3/8-16NC-2 | 4 | ea |
| | | | | WO-680310 | | | BRACKET, stowage, top bow, front (used on vehicles through serial No. 83545) | 2 | ea |
| | | | | G758-8329983 | WO-680309 | 8329983 | BRACKET, stowage, top bow, front, w/weld NUTS, assy (superseded by BRACKET WO-684296) | 2 | ea |
| | | | | WO-684295 | | | BRACKET, stowage, top bow, left, front (used on vehicles after serial No. 83545) | 1 | ea |
| | | | 5305-737-2885 | G758-8329982 G740-7372885 | WO-680312 WO-673600 | 8329982 7372885 | BRACKET, stowage, top bow, rear | 2 | ea |
| 18-16 | | | | WO-684296 | | SCREW, int-teeth lock washer, hex-hd, S, cd- or zn-pltd, 1/4-20NC-2 x 5/8 (stowage bracket and top chain thumb screw (4), top bow stowage bracket rear to side panel (4)) | 8 | ea | |
| | | | | | | BRACKET, stowage, top bow, right, front (supersedes BRACKET 8329983) | 1 | ea | |
| | | H2 | | H002-0543496 | | 543496 | BUCKLE, spare gas can strap | 1 | ea |
| | | H2 | | H002-0543486 | | 543486 | BUCKLE, tongueless, S, 1 in. (windshield hold-down strap (1), spare gas can strap (1), axe strap (1), shovel strap (1), top bow stowage strap (2), top stowage strap (4)) | 10 | ea |
| | | H2 | | H002-0585861 | | 585861 | BUCKLE, tongueless, web strap, S, cd- or zn-pltd 1 in. (auxiliary litter stowage strap (1), passenger seat stowage strap (2), axe strap (1), litter rack hold-down strap (1)) (M170) | 5 | ea |
| | | H2 | | H002-0543496 | | 543496 | BUCKLE, web strap, S, cd- or zn-pltd, 1 1/2 in. (rear litter hold-down strap (2), spare gas can strap (1)) (M170) | 3 | ea |
| | | | 2510-737-5169 | G740-7375169 | WO-674957 | 7375169 | CATCH, tool box lid | 1 | ea |
| | | | | | WO-680150 | 8677546 | DOOR, glove box, assy (complete) | 1 | ea |
| | | | | G758-8329650 | WO-680149 | 8329650 | DOOR, glove box, w HINGE (welded) | 1 | ea |
| | | H1 | 012-0361 | H001-4135661 | | 120361 | NUT, mach screw, hex, S, cd- or zn-pltd, No. 10 (0.190)-24NC-2 | 3 | ea |
| 18-6 | H1 | | | | 188926 | SCREW, ext-teeth lock washer, hex-hd, S, cd- or zn-pltd, No. 10 (0.190) 24NC 2 x 5/8 | 3 | ea | |
| | H1 | 5310-012-0391 | H001-7043621 | | 120391 | WASHER, flat, S, cd- or zn-pltd, 7/32 ID, 1/2 OD, 0.049 thk | 3 | ea | |
| | H2 | | H102-0426687 | | 426687 | EYELET, lg turn-button fastener, br, black, 5/16 lg prong | 2 | ea | |
| | | | | WO-663493 | | | HINGE, half, female (lid, tool box) | 2 | ea |

| (1) ILLUSTRATION NO. | (2) REFERENCE SYMBOLS | (3) FEDERAL STOCK NO. | (4) ORDNANCE STOCK NO. | (5) MFR'S PART NO. | (6) ORDNANCE PART NO. | (7) DESCRIPTION | (8) QUANTITY INCORPORATED IN UNIT | (9) UNIT OF ISSUE |
|--|--------------------------|--------------------------|---------------------------|-----------------------|--------------------------|---|--------------------------------------|----------------------|
| GROUP 18—BODY—Continued | | | | | | | | |
| 1808—STOWAGE AND STRAPS—Continued | | | | | | | | |
| 18-16 | | 2510-737-5350 | G740-7375350 | WO-663492 | | HINGE, half, male (body, tool box)..... | 2 | ea |
| | | | | WO-674959 | 7375350 | LID, tool box, assy (complete)..... | 1 | ea |
| 18-6 | | | | WO-674967 | 8673345 | LID, tool box, w/HINGE (welded)..... | 1 | ea |
| | | 2540-737-5399 | G740-7375399 | WO-673708 | 7375399 | LOCK, glove box door, assy..... | 1 | ea |
| | H2 | | H002-7697591 | | 7697591 | LOOP, footman (axe stowage strap (1), shovel stowage strap (1)) | 2 | ea |
| | H1 | 015-5937 | H101-0155937 | | 155937 | BOLT, MACHINE, cross-recess-fl-hd, S, cd- or zn-pltd, No. 10 (0.190)-24NC-2 x 1/2 | 4 | ea |
| | H1 | | H101-0271166 | | 271166 | NUT, hex, ext-teeth-lock washer, S, cd- or zn-pltd, No. 10-24NC-2A | 4 | ea |
| | H2 | | H002-8328423 | | | LOOP, footman (spare gas can strap) (M170)..... | 1 | ea |
| | H1 | 015-5937 | H101-0155937 | | 155937 | BOLT, MACHINE, cross-recess, fl-hd, S, cd- or zn-pltd, No. 10 (0.190)-24NC-2 x 1/2 | 2 | ea |
| | H1 | | H101-0271166 | | 271166 | NUT, hex, ext-teeth lock washer, S, cd- or zn-pltd, No. 10-24NC-2A (loop to center floor pan) | 2 | ea |
| | | | | WO-670953 | 8676953 | LOOP, footman (weld type) (shovel stowage bracket (1), axe retainer (1)) | 2 | ea |
| | | | | ONB-SN1610 | 8677317 | NUT, weld, S, No. 10-24NC (glove box panel (4), shovel stowage bracket (2)) | 6 | ea |
| | | | | WO-674898 | | | | |
| | | | | ONB-SN2113 | 8676969 | NUT, weld, S, 1/4-20NC (shovel blade retainer)..... | 2 | ea |
| | | | | WO-674350 | | | | |
| | | | | WO-680446 | | NUT, weld, S, 3/8-16NC (top bow stowage bracket, front) (use through vehicles serial No. 83545) | 2 | ea |
| | | | | WO-683864 | | PANEL, stowage compartment lid (M170)..... | 1 | ea |
| | | | | WO-677999 | | PANEL, tool box, front floor..... | 1 | ea |
| | | | G758-8329734 | WO-677963 | 8329734 | PANEL, tool box, front floor, w/HINGE, assy..... | 1 | ea |
| | | | | WO-680819 | | PIN, hinge, S, 0.125 dia x 7 in. lg (glove box door)..... | 1 | ea |
| 18-16 | | 5315-737-5166 | G740-7375166 | WO-663476 | 7375166 | PIN, hinge, S, 0.125 dia x 3 in. lg (tool box lid)..... | 2 | ea |
| | | 5340-769-7581 | G740-7697581 | WO-674230 | 7697581 | PLUG, button, 3/4 in. (ru) (glove box drain)..... | 1 | ea |
| | | | G758-8329987 | WO-681264 | 8329987 | RETAINER, axe, assy (axe blade)..... | 1 | ea |
| | | | | WO-670953 | | Composed of: | | |
| | | | | WO-681265 | | 1 LOOP | | |
| | | | | | | 1 RETAINER | | |
| | H1 | 042-5379 | H101-0425379 | | 425379 | BOLT, int-teeth lock washer, hex-hd, header-pt, S, cd- or zn-pltd, 1/4-20NC-2 x 1/2 | 2 | ea |
| | | 2510-737-5358 | G740-7375358 | WO-673709 | 7375358 | RETAINER, glove box door lock..... | 1 | ea |
| | H1 | 013-1885 | H101-0131885 | | 131885 | SCREW, mach, fil-hd, S, cd- or zn-pltd, No. 6 (0.138)-32NC-2 x 3/16 | 1 | ea |

18-5

18-8

| | | | | | | | | |
|----|---------------|--------------|--------------|-----------|---|--|----|----|
| H1 | 2540-737-5351 | H101-0425379 | WO-681261 | 8393225 | RETAINER, shovel blade, w/weld NUTS (welded) | 1 | ea | |
| | | | | 425379 | BOLT, int-teeth lock washer, hex-hd, header-pt, S, cd- or zn-pltd, 1/4-20NC-2 x 1/2 | 2 | ea | |
| H1 | 5310-012-0393 | H001-7043711 | WO-670929 | | RETAINER, tool box lid ring | 1 | ea | |
| | | | WO-950984 | | RING, tool box lid (on floor panel) | 1 | ea | |
| H1 | 2540-737-5353 | G740-7375351 | WO-674956 | 7375351 | RING, tool box lid (used on vehicles through serial No. 57255) (superseded by RING WO-684845) | 1 | ea | |
| | | | WO-684845 | | RING, tool box lid (used on vehicles after serial No. 57255) (supersedes RING 7375351) | 1 | ea | |
| H1 | 010-4052 | H001-0924028 | | 120393 | WASHER, FLAT, S, cd- or zn-pltd, 1 1/2 ID, 1 1/16 OD, 0.065 thk | 2 | ea | |
| | | | G758-8329984 | WO-674993 | 8329984 | WASHER, spring, S, cd- or zn-pltd, 2 1/64 ID, 5/8 OD | 1 | ea |
| H1 | 2510-737-5354 | G740-7375354 | G740-7375353 | WO-670926 | 7375353 | RING, tool box lid, w/RETAINER, assy | 1 | ea |
| | | | H001-0924028 | | 104052 | RIVET, b-hd, S, 1/8 x 3/8 | 2 | ea |
| | | | WO-673472 | 7375354 | SPACER, S, 1 3/32 ID, 1 OD, 5/8 lg (spare gasoline can bracket) | 4 | ea | |
| | | | WO-685786 | | STRAP, auxiliary, hold-down litter (rear (M170)) | 2 | ea | |
| | | | | 543496 | Composed of: 1 BUCKLE 1 STRAP | | | |
| | | | WO-685787 | | 1 TIP | | | |
| | | | WO-681275 | | STRAP, axe (26 in. dev-lg) | 1 | ea | |
| | | G758-8329988 | WO-681274 | 8329988 | STRAP, axe, w/BUCKLE, assy | 1 | ea | |
| | | | | 543486 | Composed of: 1 BUCKLE 1 STRAP | | | |
| | | | WO-681275 | | 1 TIP | | | |
| | | G758-8329655 | WO-680974 | 8329655 | STRAP, axe, w/BUCKLE, assy (M170) | 1 | ea | |
| | | | | 585861 | Composed of: 1 BUCKLE 1 STRAP | | | |
| | | | WO-680987 | | 1 TIP | | | |
| | | | WO-A2602 | | STRAP, hold-down, upper litter rack, assy (M170) | 2 | ea | |
| | | | WO-685789 | | Composed of: 1 BUCKLE 1 STRAP | | | |
| | | | | 585861 | 1 TIP | | | |
| | | | WO-685790 | | STRAP, hold-down, windshield (16 in. dev-lg) | 1 | ea | |
| | | G758-8329655 | WO-A2602 | | STRAP, hold-down, windshield, w/BUCKLE, assy (M38A1) | 1 | ea | |
| | | | WO-680978 | 8329655 | Composed of: 1 BUCKLE | | | |
| | | | WO-680974 | | 1 STRAP | | | |
| | | | N&J-1055 | 543486 | 1 TIP | | | |
| | | | WO-A2601 | | STRAP, hold-down, windshield, w/BUCKLE, assy (M38A1) | 1 | ea | |
| | | | WO-680987 | | Composed of: 1 BUCKLE | | | |
| | | | N&J-1 | | 1 STRAP | | | |
| | | | WO-A2602 | | 1 TIP | | | |

| (1) ILLUSTRATION NO. | (2) REFER- ENCE SYMBOLS | (3) FEDERAL STOCK NO. | (4) ORDNANCE STOCK NO. | (5) MFR'S PART NO. | (6) ORDNANCE PART NO. | (7) DESCRIPTION | (8) QUANTITY INCOR- PORATED IN UNIT | (9) UNIT OF ISSUE | |
|--|----------------------------------|-----------------------------|------------------------------|---|-----------------------------|---|---|----------------------------|--|
| GROUP 18—BODY—Continued | | | | | | | | | |
| 1808—STOWAGE AND STRAPS—Continued | | | | | | | | | |
| 18-7 | | | G758-8329988 | WO-685809 | | STRAP, passenger seat stowage (seat to toe board) (M170) | 1 | ea | |
| | | | | | 585861 | Composed of: 1 BUCKLE 1 STRAP 1 TIP | | | |
| | | | | WO-685810 WO-A2602 | | | | | |
| | | | | WO-681274 | 8329988 | STRAP, passenger seat stowage (seat to instrument panel) (M170) | 1 | ea | |
| 18-4 | H1 | 5340-769-8489 | G503-7698489 | WO-681275 WO-A2602 WO-674078 WO-674081 | | Composed of: 1 BUCKLE 1 STRAP 1 TIP | | | |
| | | | | WO-A4127 | 7698489 | STRAP, spare gas can, tip end (used w/STRAP 7698490) | 1 | ea | |
| | | | | | 543496 | STRAP, spare gas can, buckle end, 1½ in. webbing, 31 in lg (used w/STRAP 7698489) | 1 | ea | |
| | | | | WO-674081 | | STRAP, spare gas can, assy (M38A1) | 1 | ea | |
| | | | | | 113338 | Composed of: 1 BUCKLE 1 STRAP | | | |
| | | | | WO-53057 WO-685913 | | RIVET, TUBULAR, oval-hd, br, plain fin, 9/64 x 1 1/32, 1 5/64 hd dia | 4 | ea | |
| | | | | | | WASHER, FLAT, S, 5/32 ID, 7/16 OD, 0.040 thk | 4 | ea | |
| | | | | | | STRAP, spare gas can, w/BUCKLE, assy (M170) | 1 | ea | |
| | | | | | | Composed of: 1 BUCKLE 1 STRAP | | | |
| | | | | | | STRAP, spare gas can, w/end TIP, assy | 1 | ea | |
| | | 5340-769-8490 | G503-7698490 | WO-674078 | | Composed of: 1 STRAP 1 TIP | | | |
| | | | | WO-685911 | 549605 | STRAP, spare gas can, w/end TIP, assy (M170) | 1 | ea | |
| | | | | | | Composed of: 1 STRAP 1 TIP | | | |
| | | | | WO-685912 | | STRAP, spare gas can, w/end TIP, assy (M170) | 1 | ea | |
| | | | | WO-685813 | 549605 | Composed of: 1 STRAP 1 TIP | | | |
| | | | | STRAP, stowage, litter (M170) | 1 | ea | | | |
| | | | | Composed of: 1 BUCKLE | | | | | |
| | | | | | 585861 | | | | |

| | | | | | |
|----|--------------|--|---|----|----|
| H3 | H003-8329991 | WO-685815 | 1 STRAP | | |
| | | WO-A2602 | 1 TIP | | |
| | | WO-681273 | STRAP, stowage, shovel | 1 | ea |
| | | | STRAP, stowage, shovel, w/BUCKLE, assy | 1 | ea |
| | | | Composed of: | | |
| | | | 1 BUCKLE | | |
| | | | 1 STRAP | | |
| | | | 1 TIP | | |
| | | | STRAP, stowage, top (49 in. dev-lg) | 4 | ea |
| | | | STRAP, stowage, top bow (22 in. dev-lg) | 2 | ea |
| | 8329991 | STRAP, stowage, top, w/BUCKLE, assy (wheelhouse) (M38A1) | 4 | ea | |
| | | Composed of: | | | |
| | 543486 | 1 BUCKLE | | | |
| | | 1 STRAP | | | |
| | | 1 TIP | | | |
| | | STRAP, web, deck to front top bow | 2 | ea | |
| | | STRAP, web, deck to front top bow, left and right, assy (M38A1) | 2 | ea | |
| | | Composed of: | | | |
| | | 1 EYELET | | | |
| | | 1 STRAP | | | |
| | | 1 TIP | | | |
| | | 1 WASHER | | | |
| | | STRAP, web, 1 in. wide (16 in. dev-lg) (axe strap) (M170) | 1 | ea | |
| | | STRAP, web, 1 in. wide (26 in. dev-lg) (passenger seat stowage) | 1 | ea | |
| | | 426687 | STRAP, web, 1 x 25 in. (stowage top bow) (M38A1) | 2 | ea |
| | | | Composed of: | | |
| | | 543486 | 2 BUCKLE | | |
| | | | 2 STRAP | | |
| | | | 2 TIP | | |
| | | WO-681956 | STRAP, web, 1 in. wide (41½ in. dev-lg) (passenger seat stowage) (M170) | 1 | ea |
| | | N&J-1 | STRAP, web, 1 in. wide (72 in. dev-lg) (auxiliary litter stowage) (M170) | 1 | ea |
| | | WO-A2602 | STRAP, web, 1½ in. wide (67½ in. dev-lg) (rear litter hold-down) (M170) | 2 | ea |
| | | WO-685810 | STRAP, web, 1½ in. wide (33¼ in. dev-lg) (upper litter rack) (M170) | 1 | ea |
| | | WO-685815 | STRAP, web, 1½ in. wide (6.125 in. dev-lg) (spare gas can) (M170) | 1 | ea |
| | | WO-685787 | STRAP, web, 1½ in. wide (37.0 in. dev-lg) (spare gas can) (M170) | 1 | ea |
| | | WO-685790 | | | |
| | | WO-685914 | | | |
| | | WO-685912 | | | |
| H3 | H003-0592637 | | | | |
| | | | | | |
| | | | | | |
| | | | | | |
| | | | | | |
| | | | | | |
| | | | | | |
| | | | | | |
| | | | | | |
| | | | | | |

| (1) ILLUSTRATION NO. | (2) REFER- ENCE SYMBOLS | (3) FEDERAL STOCK NO. | (4) ORDNANCE STOCK NO. | (5) MFR'S PART NO. | (6) ORDNANCE PART NO. | (7) DESCRIPTION | (8) QUANTITY INCOR- PORATED IN UNIT | (9) UNIT OF ISSUE | | |
|--|----------------------------------|-----------------------------|--|-----------------------|-----------------------------|--|--|---|----|----|
| GROUP 18—BODY—Continued | | | | | | | | | | |
| 1808—STOWAGE AND STRAPS—Continued | | | | | | | | | | |
| 18-7 18-7 | H1 | | H101-0271187 | WO-685077 | | SUPPORT, auxiliary litter outer, front (M170)..... | 1 | ea | | |
| | | | | | 271187 | NUT, hex-ext-teeth lock washer, S, cd- or zn-pltd, 5/16-24NF-2B (support to retainer) | 2 | ea | | |
| | H1 | | H101-0451975 | | | 451975 | SCREW, lock washer, sltd-hex-hd, S, cd- or zn-pltd, 5/16-18NC-3 x 3/4 (support to LH w/house panel) | 2 | ea | |
| | | | | | | WO-685299 | | SUPPORT, upper litter, front, assy (M170)..... | 1 | ea |
| | H1 | 5310-012-0394 | H001-7043741 | | | 451977 | SCREW, mach, hex-hd, spring lock washer, S, cd- or zn-pltd, 3/8-16NC x 7/8 | 4 | ea | |
| | | | | | | 120394 | WASHER, FLAT, S, cd- or zn-pltd, 11/32 ID, 13/16 OD, 0.065 thk | 4 | ea | |
| | | | | | | WO-685277 | SUPPORT, spare wheel well, assy (includes weld NUTS) (welded) (M170) | 2 | ea | |
| | | | | | | WO-807971 | BOLT, assembled washer, hex hd, split lock washer, S, cd- or zn-pltd, 3/8-24UNF-2A x 3/4 (support to frame) | 4 | ea | |
| | | | | | | 451975 | SCREW, lock washer, sltd- hex-hd, S, cd- or zn-pltd, 5/16-18NC-3 x 3/4 (support to wheel well) | 4 | ea | |
| | H1 | 5310-012-0388 | H001-7045591 | | | 120388 | WASHER, FLAT, S, cd- or zn-pltd, 1/16 ID, 1 OD, 0.083 thk (support to frame) | 4 | ea | |
| | | | | | | 446470 | WASHER, FLAT, S, cd- or zn-pltd, 3/8 ID, 1 1/8 OD, 0.065 thk (support to wheel well) | 4 | ea | |
| | H2 | | H002-0549605 | | | WO-685471 | SUPPORT, top bow stabilizer boards..... | 1 | ea | |
| | | | | | | | 549605 | TIP, end, S, 1 1/2 in. (rear litter hold-down strap (2), spare gas can strap (1)) | 3 | ea |
| | | | | | | N&J-1 WO-A2602 | | TIP, strap end (windshield hold-down strap (1), spare gas can strap (1), axe strap (1), shovel strap (1), top bow stowage strap (2), top stowage strap (4)) | 10 | ea |
| | H2 | 2510-737-5355 | H102-0426686 G740-7375355 G758-8329654 | | | | N&J-1 WO-A2602 | TIP, strap end, S, 1 in. (auxiliary litter stowage strap (1), passenger seat stowage strap (2), axe strap (1), litter rack hold-down strap (1)) (M170) | 5 | ea |
| | | | | | | 426686 | WASHER, large turn button fastener eyelet, br, black..... | 2 | ea | |
| | | | | | | WO-674232 | WEATHERSTRIP, ru (tool box lid)..... | 1 | ea | |
| WO-680143 | | | | | | WEATHERSTRIP, ru, 0.44 wide, 32.65 lg, 0.22 thk (glove box door) | 1 | ea | | |
| WO-683911 | | | | | | WEATHERSTRIP, stowage compartment lid (M170)..... | 2 | ea | | |
| 1812—SPECIAL PURPOSE BODY (M170) | | | | | | | | | | |
| | | | | WO-685856 | | ARM, half, spreader, lower, upper litter rack..... | 2 | ea | | |
| | | | | WO-685853 | | ARM, half, spreader, upper, upper litter rack..... | 2 | ea | | |

| | | | | | | | |
|----|---------------|--------------|-----------|---------|--|---|----|
| | | | WO-685854 | | ARM, half, spreader, upper, upper litter rack, assy | 2 | ea |
| | | | WO-685858 | | ARM, spreader, upper litter rack, assy | 2 | ea |
| H1 | 010-4084 | H001-0924148 | | 104084 | RIVET, solid, b-hd, S, $\frac{1}{4}$ x $\frac{7}{8}$ | 2 | ea |
| | | G758-8329984 | WO-674993 | 8329984 | WASHER, spring, S, cd- or zn-pltd, $\frac{21}{64}$ ID, $\frac{5}{8}$ OD (superseded by WASHER WO-676729) | 2 | ea |
| | | | WO-676729 | | WASHER, spring tension, S, cd- or zn-pltd, $\frac{1}{4}$ ID, $\frac{5}{8}$ OD (supersedes WASHER 8329984) | 2 | ea |
| | | | WO-684937 | | BRACKET, hinge, upper litter, front | 1 | ea |
| | | | WO-687889 | | BRACKET, hinge, upper outer litter rack, assy (front and rear support half) | 1 | ea |
| | | | WO-684949 | | BRACKET, hinge, upper outer litter rack, rack half | 1 | ea |
| | | | WO-687914 | | BRACKET, hinge, upper outer litter rack, rack half, assy (front) | 2 | ea |
| | | | WO-684949 | | Composed of: | | |
| | | | WO-687912 | | 1 BRACKET | | |
| | | | WO-805002 | | 2 SPACER | | |
| | | | | | NUT, hex, ext-teeth-lock washer, S, cd- or zn-pltd, $\frac{3}{16}$ -18NC-2A | 2 | ea |
| | | | | 160693 | SCREW, mach-cross-recess, pan-hd, S, cd- or zn-pltd, $\frac{3}{16}$ -18NF x $\frac{7}{8}$ | 2 | ea |
| H1 | 5310-044-6363 | H101-0446363 | | 446363 | WASHER, flat, S, cd- or zn-pltd, $\frac{3}{8}$ ID, $\frac{7}{8}$ OD, 0.083 thk | 2 | ea |
| | | | WO-684953 | | BRACKET, retainer and pivot, upper inner litter rack | 1 | ea |
| | | | WO-805002 | | NUT, hex-ext-teeth lock washer, S, cd- or zn-pltd, No. 10-18NF-2A | 2 | ea |
| | | | | 160693 | SCREW, mach, cross-recess, pan-hd, S, cd- or zn-pltd, $\frac{3}{16}$ -18NC x $\frac{7}{8}$ | 2 | ea |
| H1 | 5310-044-6363 | H101-0446363 | | 446363 | WASHER, FLAT, S, cd- or zn-pltd, $\frac{3}{8}$ ID, $\frac{7}{8}$ OD, 0.083 thk | 2 | ea |
| | | | WO-683029 | | BRACKET, stop, upper litter rack | 2 | ea |
| | | | WO-683982 | | BRACKET, support, lower litter rack, assy | 8 | ea |
| | | | WO-685452 | | CHAIN w/retaining PIN, assy, (top side rail to windshield (2); front side curtain rod to top side rail (2)) | 4 | ea |
| | | | WO-685451 | | Composed of: | | |
| | | | WO-683850 | | 2 CHAIN | | |
| | | | WO-685451 | | 2 PIN | | |
| | | | | | CHAIN, locking pin retaining (top side rail to w/shield (2); front side curtain rod to top side rail (2)) | 4 | ea |
| H1 | 014-5371 | H001-5614921 | WO-685424 | | CHAIN, locking pin retaining | 2 | ea |
| | | | | 145371 | SCREW, DRIVE, metallic, rd-hd, S, cd- or zn-pltd, No. 2 (0.100) x $\frac{1}{4}$ (chain to locking pin) | 2 | ea |
| H1 | | H101-0271166 | WO-685781 | | CLIP, retaining, hanging support | 1 | ea |
| | | | | 271166 | NUT, hex, ext-teeth lock washer, S, cd- or zn-pltd, No. 10-24NC-2A | 2 | ea |
| H1 | | H101-0157684 | | 157684 | SCREW, MACHINE, truss hd, cross-recess, S, cd- or zn-pltd, No. 10-24NC-2 x $\frac{1}{2}$ | 2 | ea |

| (1) ILLUSTRATION NO. | (2) REFERENCE SYMBOLS | (3) FEDERAL STOCK NO. | (4) ORDNANCE STOCK NO. | (5) MFR'S PART NO. | (6) ORDNANCE PART NO. | (7) DESCRIPTION | (8) QUANTITY INCORPORATED IN UNIT | (9) UNIT OF ISSUE | |
|---|--------------------------|--------------------------|--------------------------------|-------------------------------------|-------------------------------------|--|--|----------------------|----|
| GROUP 18—BODY—Continued | | | | | | | | | |
| 1812—SPECIAL PURPOSE BODY (M170)—Continued | | | | | | | | | |
| 18-5, 15 | H1 | 010-4137 | H001-0925030 | WO-685850 | 104137 | CLIP, spring, spreader arm | 2 | ea | |
| | | | | | | RIVET, SOLID, ck-hd, S, $\frac{1}{8}$ x $\frac{1}{2}$ | 4 | ea | |
| | H1 | | | H101-0454789 | WO-685388 | 454789 | COVER, plate, trailer receptacle (body rear panel) | 1 | ea |
| | | | | | | | SCREW, assembled washer, cross-recess-pan-hd, inter-teeth lock washer, header-pt, S, cd- or zn-pltd, $\frac{1}{4}$ -20UNC-2A x $\frac{1}{2}$ (body rear panel) | 4 | ea |
| | | | | | WO-685527 | | CUSHION, wheelhouse, left side, assy (superseded by CUSHION WO-691543) | 2 | ea |
| | | | | | WO-685529 WO-685366 WO-691543 | | Composed of: 1 COVER 1 PAD | | |
| | | | | | WO-685529 WO-691396 WO-52990 | 7418660 | CUSHION, wheelhouse, left side, assy (supersedes CUSHION WO-685527) | 2 | ea |
| | | | | | | | Composed of: 1 COVER 1 PAD | | |
| | | H1 | 2510-495-3672 5310-014-0241 | G503-7418660 H101-0140241 | WO-52990 | 140241 | SCREW, tapping, oval-hd, S, cd- or zn-pltd, No. 10-12 x $\frac{1}{2}$ | 10 | ea |
| | | | | | | | WASHER, FINISHING, S, cd- or zn-pltd, No. 10 (0.190) | 10 | ea |
| | | | | WO-685528 | | CUSHION, wheelhouse, right side, assy (superseded by CUSHION WO-691544) | 2 | ea | |
| | | | | WO-685530 WO-685361 WO-691544 | | Composed of: 1 COVER 1 PAD | | | |
| 18-5 | | | | | | CUSHION, wheelhouse, right side, assy (supersedes CUSHION WO-685528) | 2 | ea | |
| | | | | | | Composed of: 1 COVER 1 PAD | | | |
| 18-15 | | 2510-495-3672 | G503-7418660 | WO-52990 | 7418660 | SCREW, tapping, oval-hd, S, cd- or zn-pltd, No. 10-12 x $\frac{1}{2}$ | 10 | ea | |
| 18-15 | H1 | 5310-014-0241 | H101-0140241 | | 140241 | WASHER, FINISHING, S, cd- or zn-pltd, No. 10 (0.190) | 10 | ea | |
| | H1 | | | WO-685785 | | HANGER, rear, inner litter rack | 1 | ea | |
| | H1 | | H101-0137168 | | 137168 | PIN, COTTER, split, S, cd- or zn-pltd, $\frac{3}{32}$ x $\frac{7}{8}$ | 1 | ea | |
| | H1 | | H001-7043801 | | 120396 | WASHER, S, cd- or zn-pltd, $\frac{1}{32}$ ID, $1\frac{1}{16}$ OD, $\frac{3}{32}$ thk | 1 | ea | |

| | | | | | | | |
|----|---------------|--------------|-----------|---------|--|---|----|
| | | | WO-684999 | | HINGE, half, litter rack, front, upper, outer | 1 | ea |
| | | | WO-805002 | | NUT, hex, ext-teeth-lock washer, S, cd- or zn-pltd, 5/16-18NC-2A | 2 | ea |
| | | | | 160693 | SCREW, mach, cross-recess, pan-hd, S, cd- or zn-pltd, 5/16-18NF x 7/8 | 2 | ea |
| H1 | | H101-0446363 | | 446363 | WASHER, flat, S, cd- or zn-pltd, 3/8 ID, 7/8 OD, 0.083 thk | 2 | ea |
| | | | WO-684949 | | HINGE, half, litter rack, rear, upper, outer | 1 | ea |
| | | | WO-685433 | | HINGE, locking pin w CHAIN (upper litter rack hinge, front and rear) | 2 | ea |
| | | | WO-685424 | | Composed of: | | |
| | | | WO-684957 | | 1 CHAIN | | |
| | | | | | 1 HINGE and PIN | | |
| | | | | 145371 | 1 SCREW | | |
| | | | WO-684957 | | HINGE, w locking PIN (upper litter rack hinge, front and rear) | 2 | ea |
| | | | WO-684975 | | HOOK, plasma container | 2 | ea |
| H1 | 012-1893 | H101-0121893 | | 121893 | BOLT, MACHINE, S, cd- or zn-pltd, 1/4-20NC-2B x 7/8 | 4 | ea |
| H1 | | H101-0271172 | | 271172 | NUT, mach screw, hex, ext-teeth lock washer, S, cd- or zn-pltd, 1/4 20NC-2B | 4 | ea |
| H1 | 5310-012-0393 | H001-7043711 | | 120393 | WASHER, FLAT, S, cd- or zn-pltd, 9/32 ID, 5/8 OD, 0.065 thk (plasma container hook to stabilizer board) | 4 | ea |
| | | | WO-685930 | | INSERT, upper litter support | 4 | ea |
| | | | WO-683913 | | LID, stowage compartment, assy (complete) | 1 | ea |
| | | | WO-683912 | | LID, stowage compartment w HINGE (welded) | 1 | ea |
| | | | WO-685366 | | PAD, wheelhouse cushion, left side (superseded by PAD WO 691396) | 1 | ea |
| | | | WO-691396 | | PAD, wheelhouse cushion, left side (Tapatco) (super- sedes PAD WO 685366) | 1 | ea |
| | | | WO-685361 | | PAD, wheelhouse cushion, right side (superseded by PAD WO 691397) | 2 | ea |
| | | | WO-691397 | | PAD, wheelhouse cushion, right side (Tapatco) (super- sedes PAD WO 685361) | 2 | ea |
| | | | WO-684962 | | PIN, locking, litter rack, upper, inner | 1 | ea |
| | | | | 443126 | PIN, grooved, S, cd- or zn-pltd, 5/8 x 7/64 | 1 | ea |
| | | | WO-683850 | | PIN, retaining (top side rail to w shield (2), front side curtain rod to top side rail (2)) | 4 | ea |
| | | | WO-685851 | | PLATE, spreader arm | 4 | ea |
| H1 | 5320-010-4167 | H001-0925162 | | 104167 | RIVET, SOLID, ck-hd, S, 1/4 x 3/4 | 2 | ea |
| | | G758-8329984 | | 8329984 | WASHER, spring, S, cd- or zn-pltd, 21/64 ID, 5/8 OD (superseded by WASHER WO 676729) | 4 | ea |
| | | | WO-676729 | | WASHER, spring tension, S, cd- or zn-pltd, 1/4 ID, 5/8 OD (supersedes WASHER 8329984) (upper lower spreader arm) | 2 | ea |
| | | | WO-685783 | | PLATE, support, inner upper litter rack | 1 | ea |
| | | | WO-684972 | | RACK, litter, inner upper (welded) | 1 | ea |

| (1) ILLUSTRATION NO. | (2) REFER- ENCE SYMBOLS | (3) FEDERAL STOCK NO. | (4) ORDNANCE STOCK NO. | (5) MFR'S PART NO. | (6) ORDNANCE PART NO. | (7) DESCRIPTION | (8) QUANTITY INCOR- PORATED IN UNIT | (9) UNIT OF ISSUE |
|---|----------------------------------|-----------------------------|------------------------------|-----------------------|-----------------------------|--|---|----------------------------|
| GROUP 18—BODY—Continued | | | | | | | | |
| 1812—SPECIAL PURPOSE BODY (M170)—Continued | | | | | | | | |
| 18-5, 14 | H1 | | H101-0451975 | WO-684940 | 451975 | RACK, litter lower, assy..... | 2 | ea |
| | H1 | 5310-044-6470 | H101-0446470 | | | SCREW, lock washer, sltd, hex-hd, S, cd- or zn-pltd, 5/16-18NC-3 x 3/4 | 8 | ea |
| | | | | | | WASHER, FLAT, S, cd- or zn-pltd, 3/8 ID, 1 1/8 OD, 0.065 thk (lower litter rack to floor pan) | 8 | ea |
| | | | | | | RACK, litter, outer upper, assy..... | 1 | ea |
| 18-5, 15 | | | | | | RACK, litter, upper, inner and outer..... | 2 | ea |
| | | | | | | RACK, upper litter, assy..... | 1 | ea |
| | | | | | | REST, back, wheelhouse seat..... | 2 | ea |
| | H1 | 012-8417 | H001-3057051 | | 128417 | BOLT, SQUARE NECK, step, S, cd- or zn-pltd, 5/16-18NC-2 x 7/8 | 4 | ea |
| | | | | | | NUT, PLAIN, HEXAGON, lt, s-fin, S, cd- or zn-pltd, 5/16-18NC-2 | 4 | ea |
| | | | | | | WASHER, FLAT, plain, S, cd- or zn-pltd, 3/8 ID, 7/8 OD, 0.083 thk (back rest to front and right rear top bow) | 4 | ea |
| | | | | | | RETAINER, auxiliary litter outer front, assy..... | 1 | ea |
| | | | | | | NUT, hex, lt, ext-teeth lock washer, S, cd- or zn-pltd, 5/16-24NF-2B | 2 | ea |
| | | | | | | RETAINER, front litter..... | 2 | ea |
| | | | | | | RIVET, SOLID, b-hd, S, 1/4 x 1 1/16..... | 4 | ea |
| | | | | | | RETAINER, hanger, litter rack, upper, inner..... | 1 | ea |
| | | | | | | RETAINER, lower front litter, assy..... | 1 | ea |
| | | | | | | BOLT, MACHINE, assembled washer, hex-hd, split lock washer, header-pt, S, cd- or zn-pltd, 5/16-18UNC- 2A x 5/8 | 2 | ea |
| | | | | | | NUT, PLAIN, HEXAGON, lt, s-fin, S, cd- or zn-pltd, 5/16-18NC-2 | 2 | ea |
| 18-14 | | | | | | ROD, support, hanging, litter rack, upper, inner..... | 1 | ea |
| | | | | | | PIN, COTTER, split, S, pltd, 3/32 x 7/8..... | 1 | ea |
| | | | | | | WASHER, FLAT, S, cd- or zn-pltd, 1 1/32 ID, 1 1/16 OD, 0.095 thk | 1 | ea |
| | | | | | | SCREW, DRIVE, metallic, rd-hd, S, No. 2 (0.100) x 1/4 (upper litter rack hinge, front and rear) | 2 | ea |
| | | | | | | SPACER, hinge bracket, upper outer litter rack, rack half | 2 | ea |
| | | | | | | STOP, rear, upper and inner, litter rack..... | 2 | ea |
| | | | | | | SUPPORT, auxiliary litter, outer, front..... | 1 | ea |
| | | | | | | WO-687912 | | |
| | | | | | | WO-688119 | | |
| | | | | | | WO-687887 | | |

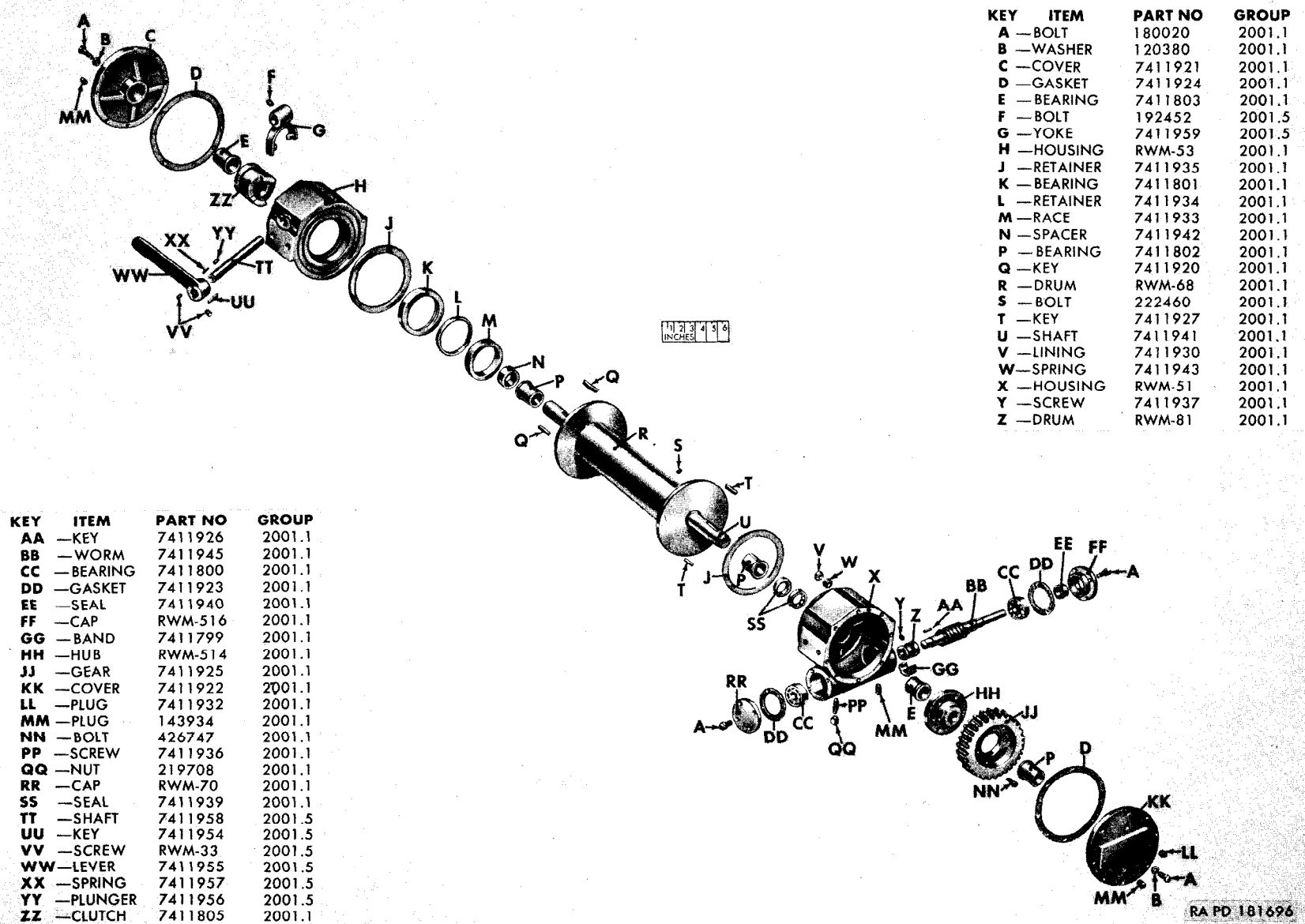

Figure 20-1. Winch, assy (7411944)—exploded view

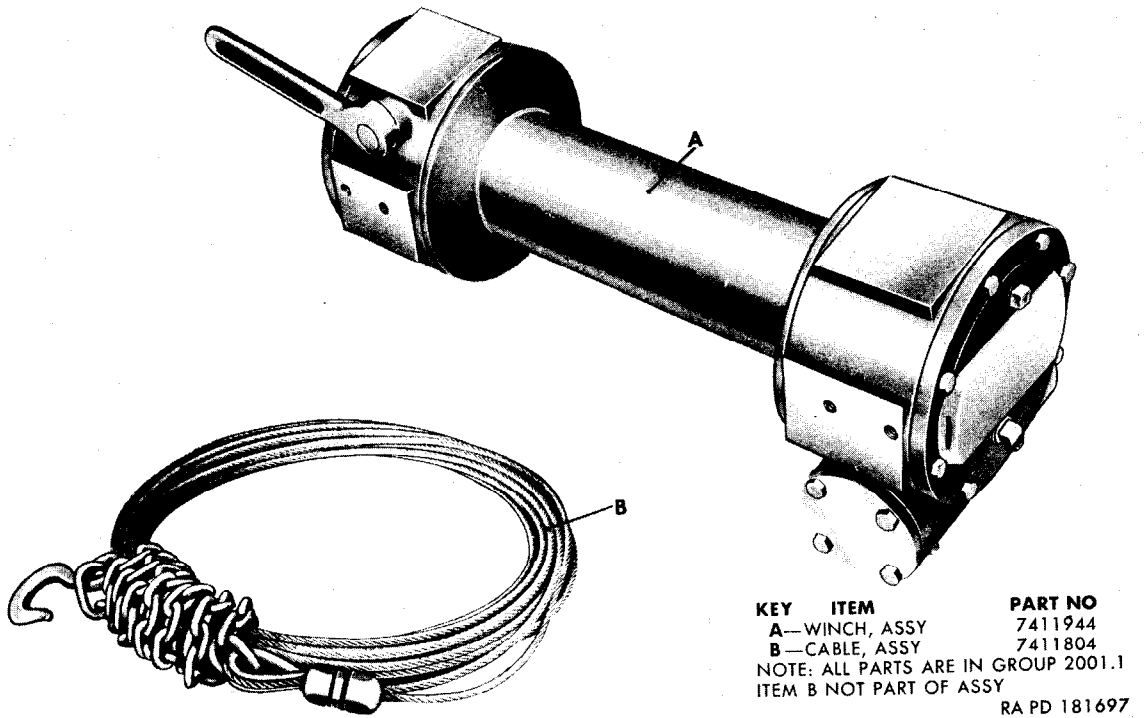

Figure 20-2. Winch, assy and related parts

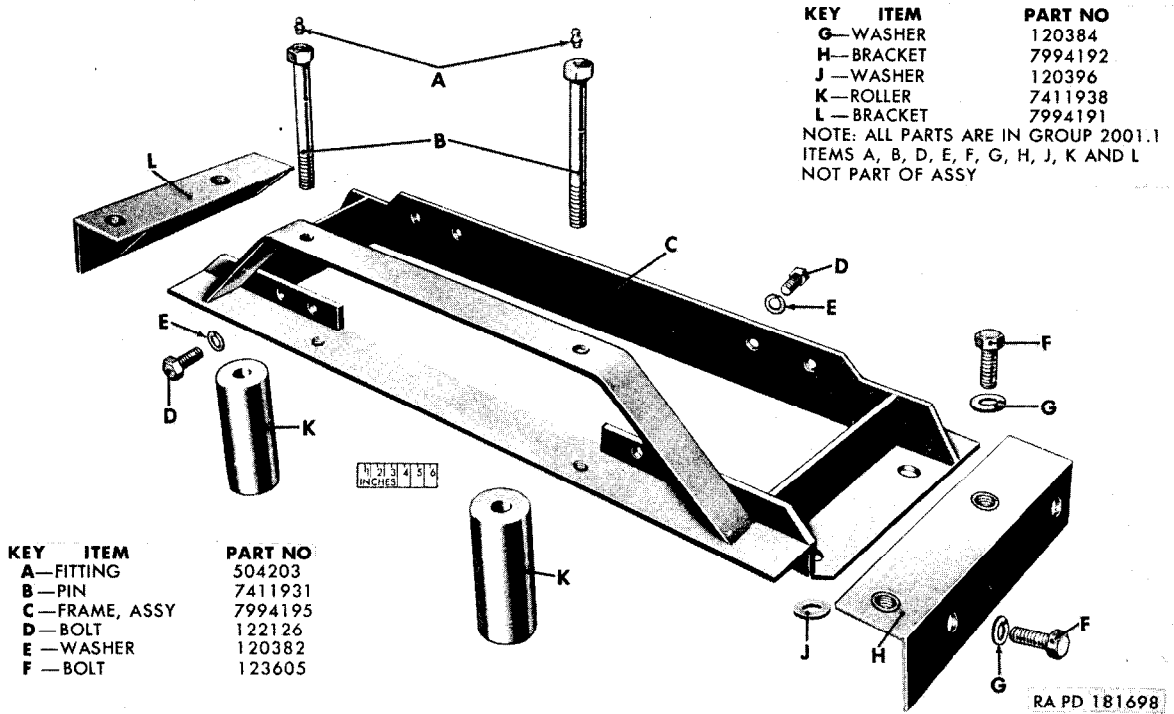
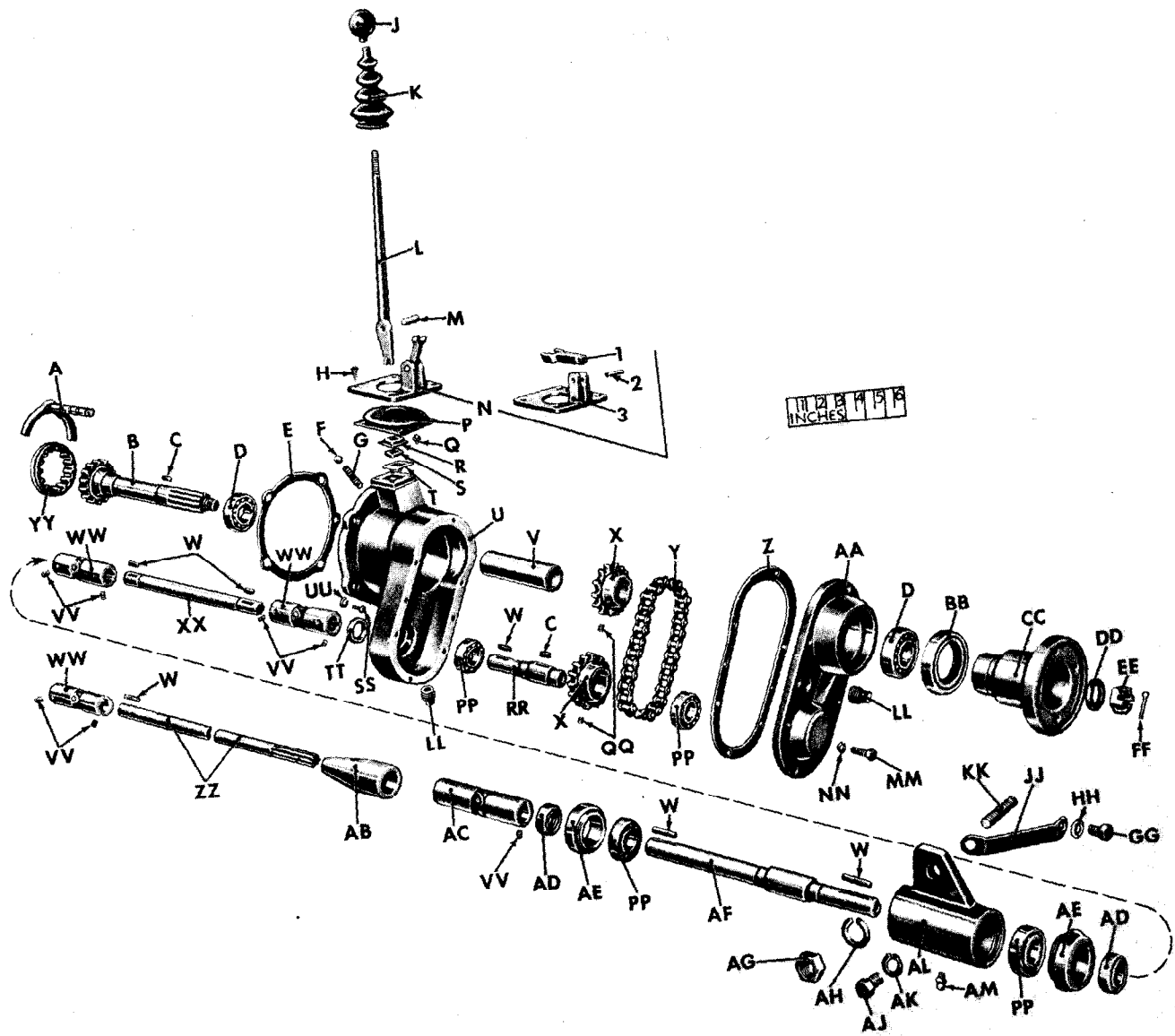

Figure 20-3. Winch frame and related parts



RA PD 367161

Figure 20-4. Power-take-off and controls

| Key | Item | Part No. | Group | Key | Item | Part No. | Group |
|-----|--------------|-----------|--------|-----|----------|-----------|--------|
| A | -SHAFT, ASSY | SP-6510X | 2002.5 | FF | -PIN | 103387 | 2002.1 |
| B | -GEAR | 7411963 | 2002.1 | GG | -BOLT | 122279 | 2001.3 |
| C | -KEY | RWM-133 | 2002.1 | HH | -WASHER | 8332514 | 2001.3 |
| D | -BEARING | 700078 | 2002.1 | JJ | -BRACE | 7994190 | 2001.3 |
| E | -GASKET | 7373162 | 0801 | KK | -STUD | 103260 | 0103 |
| F | -BALL | 7411974 | 2002.5 | LL | -PLUG | 143934 | 2002.1 |
| G | -SPRING | 7411983 | 2002.5 | MM | -BOLT | 120854 | 2002.1 |
| H | -SCREW | 161901 | 2002.5 | NN | -WASHER | 120380 | 2002.1 |
| J | -KNOB | 7696491 | 2002.5 | PP | -BEARING | 701170 | 2001.3 |
| K | -SEAL | 7361994 | 2002.5 | | | | 2002.1 |
| L | -LEVER | 7411977 | 2002.5 | QQ | -BOLT | 192452 | 2002.1 |
| M | -PIN | 117877 | 2002.5 | RR | -SHAFT | 7411967 | 2002.1 |
| N | -LATCH, ASSY | 8329889 | 2002.5 | SS | -BOLT | 120233 | 2002.1 |
| | 1-BRACKET | WO-804765 | 2002.5 | TT | -SEAL | 7411940 | 2002.1 |
| | 2-PIN | 7411980 | 2002.5 | UU | -WASHER | 120930 | 2002.1 |
| | 3-LATCH | 7411976 | 2002.5 | VV | -SCREW | RWM-87 | 2001.3 |
| P | -BOOT | 7375153 | 2002.5 | WW | -JOINT | 7994196 | 2001.3 |
| Q | -SCREW | RWM-129 | 2002.5 | XX | -SHAFT | RWM-95A | 2001.3 |
| R | -COVER | 7411975 | 2002.5 | YY | -GEAR | 7411964 | 2002.1 |
| S | -RETAINER | 7411981 | 2002.5 | ZZ | -SHAFT | WO-119277 | 2001.3 |
| T | -PLATE | RWM-130 | 2002.5 | AB | -SEAL | 7411687 | 2001.3 |
| U | -HOUSING | RWM-96 | 2002.1 | AC | -JOINT | 7994197 | 2001.3 |
| V | -SPACER | 7411970 | 2002.1 | AD | -SEAL | 7411950 | 2001.3 |
| W | -KEY | 7411690 | 2001.3 | AE | -CAP | RWM-76 | 2001.3 |
| | | | 2002.1 | AF | -SHAFT | RWM-77 | 2001.3 |
| X | -SPROCKET | 7411971 | 2002.1 | AG | -NUT | 124634 | 2001.3 |
| Y | -CHAIN | 7411961 | 2002.1 | AH | -WASHER | 120898 | 2001.3 |
| Z | -GASKET | 7411962 | 2002.1 | AJ | -BOLT | 123520 | 2001.3 |
| AA | -COVER | RWM-97 | 2002.1 | AK | -WASHER | 120382 | 2001.3 |
| BB | -SEAL | 7411966 | 2002.1 | AL | -CASE | RWM-75 | 2001.3 |
| CC | -ADAPTER | RWM-138 | 2002.1 | AM | -FITTING | RWM-80 | 2001.3 |
| DD | -WASHER | 7411972 | 2002.1 | | | | |
| EE | -NUT | RWM-140 | 2002.1 | | | | |

Figure 20-4. Power-take-off and controls—legend

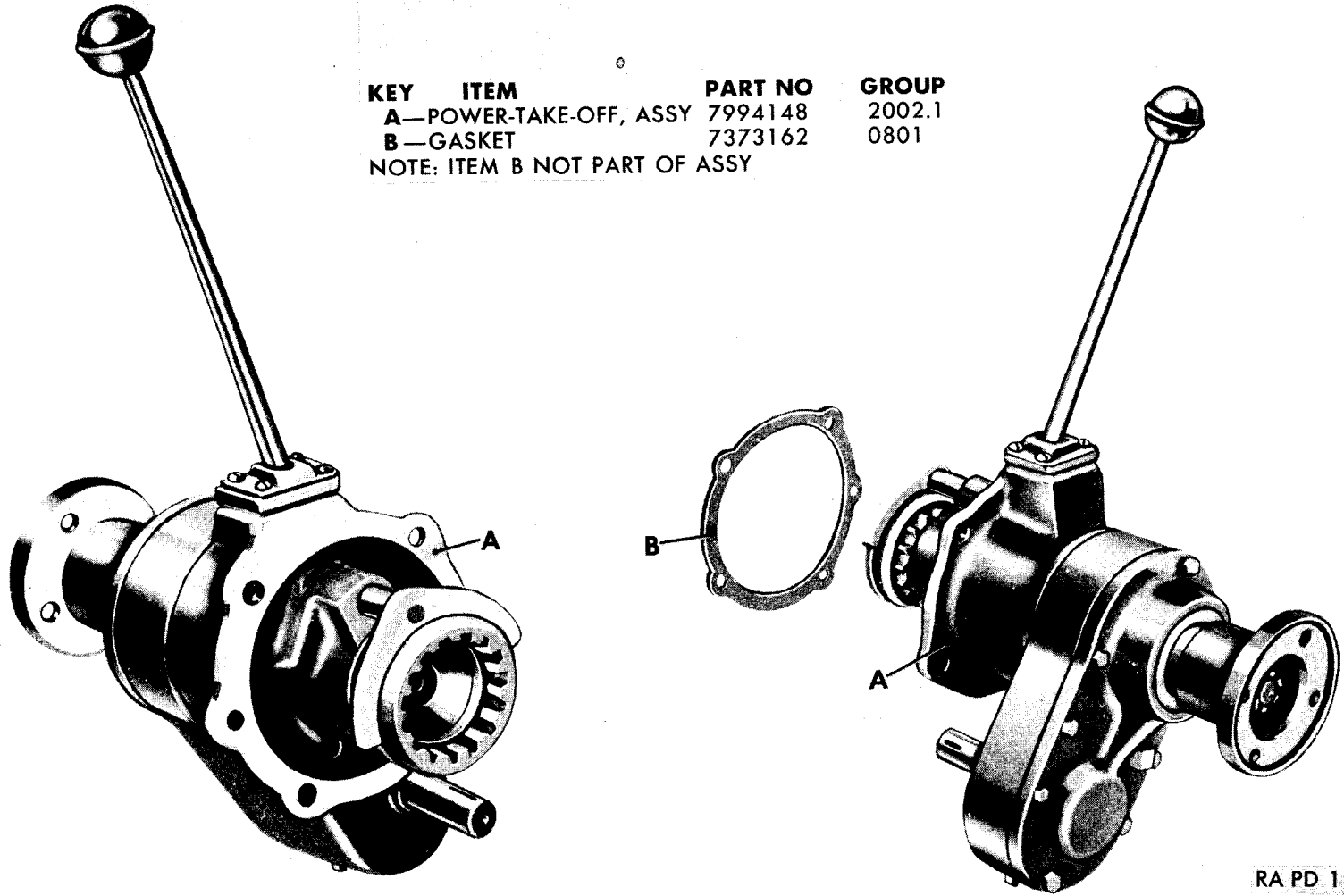

RA PD 181699

Figure 20-5. Power-take-off (7994148) and related parts

| (1) | (2) | (3) | (4) | (5) | (6) | (7) | (8) | (9) |
|--|-------------------|-------------------|--------------------|----------------------|-------------------|--|-------------------------------|---------------|
| ILLUSTRATION NO. | REFERENCE SYMBOLS | FEDERAL STOCK NO. | ORDNANCE STOCK NO. | MFR'S PART NO. | ORDNANCE PART NO. | DESCRIPTION | QUANTITY INCORPORATED IN UNIT | UNIT OF ISSUE |
| GROUP 20—WINCH AND POWER-TAKE-OFF | | | | | | | | |
| 2001.1—WINCH ASSEMBLY AND DRUM | | | | | | | | |
| 20-1 | | 2520-741-1799 | G740-7411799 | RWM-82 WO-118237 | 7411799 | BAND, brake worm..... | 1 | ea |
| 20-1 | | 3110-741-1800 | G740-7411800 | RWM-517 WO-118235 | 7411800 | BEARING, ball, worm shaft..... | 2 | ea |
| 20-1 | | 3120-741-1801 | G740-7411801 | RWM-62 WO-118253 | 7411801 | BEARING, clutch housing..... | 1 | ea |
| 20-1 | | 3120-741-1802 | G740-7411802 | RWM-511 WO-118232 | 7411802 | BEARING, bz, 1¼ ID, 1 ²³ / ₃₂ OD, 1¼ lg (drum shaft (2), worm gear housing cover (1)) | 3 | ea |
| 20-1 | | 3120-741-1803 | G740-7411803 | RWM-98 WO-118233 | 7411803 | BEARING, 1¼ ID, 1 ²³ / ₃₂ OD, 1 lg (worm gear housing)... | 2 | ea |
| 20-3 | | | | WO-802255 | 7994192 | BRACKET ASSY, winch frame support, LH..... | 1 | ea |
| 20-3 | | | | RWM-143 WO-801768 | 7994191 | BRACKET ASSY, winch frame support, RH..... | 1 | ea |
| 20-3 | H1 | 012-3605 | H101-0123605 | | 123605 | BOLT, MACHINE, cap, hex-hd, S, cd- or zn-pltd, ½- 20NF-3 x 1 | 4 | ea, |
| 20-3 | H1 | 5310-012-0384 | H001-7025801 | | 120384 | WASHER, lock, med, S, cd- or zn-pltd, ½ in..... | 4 | ea |
| 20-2 | | 4010-741-1804 | G740-7411804 | WO-800580 | 7411804 | CABLE, w/HOOK, assy..... | 1 | ea |
| 20-1 | | | | RWM-70 WO-118241 | | CAP, closed end bearing..... | 1 | ea |
| 20-1 | | | | RWM-516 WO-118242 | | CAP, worm shaft bearing..... | 1 | ea |
| 20-1 | H1 | 018-0020 | H001-5451641 | | 180020 | BOLT, MACHINE, hex-hd, S, 85,000 psi yield strength, cd- or zn-pltd, ¼-20NC-3 x ¾ | 8 | ea |
| | H8 | | H008-0819775 | | 42-C-14761 -10 | CHAIN, welded, stght link, high carbon, high test, S, natural, nom size 5/16 in. | † | ft |
| 20-1 | | 2520-741-1805 | G740-7411805 | RWM-60 WO-118256 | 7411805 | CLUTCH, winch..... | 1 | ea |
| 20-1 | | 5315-741-1920 | G740-7411920 | RWM-512 WO-118257 | 7411920 | KEY, sq, rd ends, dl-rd, 5/16 sq x 1½..... | 2 | ea |
| 20-1 | | 2520-741-1921 | G740-7411921 | RWM-57 WO-118251 | 7411921 | COVER, clutch housing..... | 1 | ea |
| 20-1 | H1 | 018-0020 | H001-5451641 | | 180020 | BOLT, MACHINE, hex-hd, S, 85,000 psi yield strength, cd- or zn-pltd, ¼-20NC-3 x ¾ | 8 | ea |
| 20-1 | H1 | 5310-012-0380 | H001-7025681 | | 120380 | WASHER, lock, med, S, cd- or zn-pltd, ¼ in..... | 8 | ea |
| 20-1 | | 2520-741-1922 | G740-7411922 | RWM-52 WO-118222 | 7411922 | COVER, worm gear housing..... | 1 | ea |
| 20-1 | H1 | 018-0020 | H001-5451641 | | 180020 | BOLT, MACHINE, hex-hd, S, 85,000 psi yield strength, cd- or zn-pltd, ¼-20NC-3 x ¾ | 8 | ea |
| 20-1 | H1 | 5310-012-0380 | H001-7025681 | | 120380 | WASHER, lock, med, S, cd- or zn-pltd, ¼ in..... | 8 | ea |

353

2001.1

2001.1

354

| (1) | (2) | (3) | (4) | (5) | (6) | (7) | (8) | (9) |
|------------------|-------------------|-------------------|--------------------|-----------------------|-------------------|---|-------------------------------|---------------|
| ILLUSTRATION NO. | REFERENCE SYMBOLS | FEDERAL STOCK NO. | ORDNANCE STOCK NO. | MFR'S PART NO. | ORDNANCE PART NO. | DESCRIPTION | QUANTITY INCORPORATED IN UNIT | UNIT OF ISSUE |
| | | | | | | GROUP 20—WINCH AND POWER-TAKE-OFF—Continued | | |
| | | | | | | 2001.1—WINCH ASSEMBLY AND DRUM—Continued | | |
| 20-1 | | | | RWM-81 WO-118236 | | DRUM, brake, worm..... | 1 | ea |
| 20-1 | | | | RWM-68 WO-118246 | | DRUM, winch..... | 1 | ea |
| 20-1 | H1 | 022-2460 | H101-0222460 | | 222460 | BOLT, set, hex-socket, fl-pt, alloy-S, $\frac{5}{16}$ -18NC 3 x $\frac{3}{8}$ | 1 | ea |
| 20-3 | H16 | 050-4203 | H016-0504203 | | 504203 | FITTING, LUBRICATION, type, stght, $\frac{1}{4}$ -28NF, male (vertical roller guide pin) | 2 | ea |
| | | | | RWM-166B WO-801767 | 7994193 | FRAME ASSY, complete, winch (includes FRAME 7994195) | 1 | ea |
| 20-3 | | | | RWM-100 WO-118267 | 7994195 | FRAME, winch, assy (welded)..... | 1 | ea |
| 20-3 | H1 | 012-3605 | H101-0123605 | | 123605 | BOLT, mach, hex-hd, S, cd- or zn-pltd, $\frac{1}{2}$ -20NF-3 x 1..... | 4 | ea |
| 20-3 | H1 | 5310-012-0384 | H001-7025801 | | 120384 | WASHER, lock, med, S, cd- or zn-pltd, $\frac{1}{2}$ in..... | 4 | ea |
| 20-1 | | 2520-741-1923 | G740-7411923 | RWM-556 WO-118243 | 7411923 | GASKET, bearing cap, 2.062 ID, 3.000 OD, 0.016 thk..... | 2 | ea |
| 20-1 | | 2520-741-1924 | G740-7411924 | RWM-56 WO-118223 | 7411924 | GASKET, worm gear housing cover, 5.406 ID, 6.438 OD, 0.625 thk | 2 | ea |
| 20-1 | | 2520-741-1925 | G740-7411925 | RWM-55 WO-118229 | 7411925 | GEAR, 2.250 ID, 50-T, 5.200 OD, 1.000 face, bz, helical (drum shaft drive) | 1 | ea |
| 20-1 | H1 | 042-6747 | H101-0426747 | | 426747 | BOLT, mach, socket-hd, alloy-S, cd- or zn-pltd, $\frac{1}{4}$ - 20NC-3 x $\frac{5}{8}$ | 6 | ea |
| | H8 | | H008-0591193 | | 591193 | HOOK, winch cable..... | 1 | ea |
| 20-1 | | | | RWM-53 WO-118250 | | HOUSING, clutch..... | 1 | ea |
| 20-1 | | | | RWM-51 WO-118221 | | HOUSING, worm gear..... | 1 | ea |
| 20-1 | | | | RWM-514 WO-118230 | | HUB, worm gear..... | 1 | ea |
| | | | | RWM-89 WO-118266 | | KEY, winch..... | 1 | ea |
| 20-1 | | 5315-741-1926 | G740-7411926 | RWM-577 WO-118240 | 7411926 | KEY, worm brake drum..... | 1 | ea |
| 20-1 | | 5315-741-1927 | G740-7411927 | RWM-513 WO-118231 | 7411927 | KEY, worm gear..... | 2 | ea |
| 20-1 | | 2530-741-1930 | G740-7411930 | RWM-519 WO-118244 | 7411930 | LINING, brake drum..... | 1 | ea |
| | H8 | | H008-7717021 | | 7717021 | LINK, repair (winch cable chain)..... | 2 | ea |

| | | | | | | | | |
|---------|----|---------------|--------------|----------------------|---------|--|---|----|
| 20-3 | | 5315-741-1931 | G740-7411931 | RWM-558 WO-118282 | 7411931 | PIN, guide, vertical roller..... | 2 | ea |
| 20-1 | | 2540-741-1932 | G740-7411932 | RWM-39 WO-118224 | 7411932 | PLUG, breather..... | 1 | ea |
| 20-1 | H6 | 014-3934 | H106-0143934 | | 143934 | PLUG, PIPE, sq-hd, CI, cd- or zn-pltd, 3/8 in. (gear housing filler (1), drain (2)) | 3 | ea |
| 20-1 | | 3110-741-1933 | G740-7411933 | RWM-61 WO-118252 | 7411933 | RACE, intermediate bearing..... | 1 | ea |
| 20-1 | | 2520-741-1934 | G740-7411934 | RWM-63 WO-118254 | 7411934 | RETAINER, grease, clutch housing bearing..... | 1 | ea |
| 20-1 | | 2520-741-1935 | G740-7411935 | RWM-64 WO-118249 | 7411935 | RETAINER, grease, drum..... | 2 | ea |
| 20-3 | | 2530-741-1938 | G740-7411938 | RWM-557 WO-118281 | 7411938 | ROLLER, vertical (guide pin)..... | 2 | ea |
| 20-1 | | 5305-741-1936 | G740-7411936 | RWM-83 WO-118238 | 7411936 | SCREW, adjusting, worm brake..... | 1 | ea |
| 20-1 | H1 | 021-9708 | H001-4019541 | | 219708 | NUT, plain, hexagon, reg, s-fin, S, cd- or zn-pltd, 3/8-24NF-2 | 1 | ea |
| 20-1 | | 5305-741-1937 | G740-7411937 | RWM-153 WO-118239 | 7411937 | SCREW, set, 1/4-20NC x 1/4 (worm brake)..... | 1 | ea |
| 20-1 | | 5330-741-1939 | G740-7411939 | RWM-99 WO-118248 | 7411939 | SEAL, grease, drum shaft..... | 2 | ea |
| 20-1 | | 5330-741-1940 | G740-7411940 | RWM-515 WO-118205 | 7411940 | SEAL, grease, worm gear..... | 1 | ea |
| 20-1 | | 2520-741-1941 | G740-7411941 | RWM-69 WO-118247 | 7411941 | SHAFT, drum..... | 1 | ea |
| 20-1 | | 2520-741-1942 | G740-7411942 | RWM-506 WO-118255 | 7411942 | SPACER, clutch..... | 1 | ea |
| 20-1 | | 5340-741-1943 | G740-7411943 | RWM-520 WO-118245 | 7411943 | SPRING, drum brake lining..... | 1 | ea |
| 20-3 | H1 | 5310-012-0396 | H001-7043801 | | 120396 | WASHER, flat, S, cd- or zn-pltd, 17/32 ID, 1 1/16 OD, 0.095 thk (winch frame to support bracket) | 1 | ea |
| | | | | WO-801766 | 7994200 | WINCH, w/KEY, assy..... Composed of: | 1 | ea |
| | | | | RWM-89 | 7411944 | 1 KEY | | |
| | | | | | 122126 | 1 WINCH | | |
| 20-3 | H1 | 012-2126 | H001-5420541 | | 122126 | BOLT, mach, hex-hd, S, cd- or zn-pltd, 3/8-16NC-3 x 7/8 | 8 | ea |
| 20-3 | H1 | 5310-012-0382 | H001-7025741 | | 120382 | WASHER, lock, med, S, cd- or zn-pltd, 3/8 in | 8 | ea |
| 20-1, 2 | | 3830-741-1944 | G740-7411944 | RWM-73A WO-118220 | 7411944 | WINCH, w/o KEY, assy..... | 1 | ea |
| 20-1 | | 2520-741-1945 | G740-7411945 | RWM-67 WO-118234 | 7411945 | WORM (gear housing)..... | 1 | ea |

| (1) ILLUSTRATION NO. | (2) REFERENCE SYMBOLS | (3) FEDERAL STOCK NO. | (4) ORDNANCE STOCK NO. | (5) MFR'S PART NO. | (6) ORDNANCE PART NO. | (7) DESCRIPTION | (8) QUANTITY INCORPORATED IN UNIT | (9) UNIT OF ISSUE |
|--|--------------------------|--------------------------|---------------------------|-----------------------|--------------------------|---|--------------------------------------|----------------------|
| GROUP 20—WINCH AND POWER-TAKE-OFF—Continued | | | | | | | | |
| 2001.3—WINCH DRIVE SHAFT | | | | | | | | |
| 20-4 | H12 | | H012-1306020 | | 701170 | BEARING, ball, MIL-STD-CODE 111-02010-0000 (rad, SR, extra lt, non-loading groove, type 1, 0.7874 bore, 1.6535 OD, 0.4724 width) (hanger) | 2 | ea |
| 20-4 | | | G740-7994190 | RWM-148 WO-801869 | 7994190 | BRACE, hanger bearing | 1 | ea |
| 20-4 | H1 | 5305-012-3520 | H001-5421221 | | 123520 | BOLT, MACHINE, hex-hd, S, cd- or zn-pltd, $\frac{3}{8}$ -24NF-3 x $\frac{3}{4}$ | 1 | ea |
| 20-4 | H1 | 6550-012-2279 | H101-0122279 | | 122279 | BOLT, mach, hex-hd, S, cd- or zn-pltd, $\frac{1}{16}$ -14NC-3 x 1 $\frac{1}{2}$ | 1 | ea |
| | H1 | 5310-011-6104 | H001-1525020 | | 116104 | WASHER, FLAT, cop, $\frac{15}{32}$ ID, $\frac{59}{64}$ OD, 0.065 thk (superseded by WASHER 8332514) | 2 | ea |
| 20-4 | | | G758-8332514 | WO-809706 | 8332514 | WASHER, LOCK, ext-teeth, S, blk-oiled-fin, $\frac{1}{16}$ ID, $\frac{3}{4}$ OD, 0.020 thk (supersedes WASHER 116104) | 1 | ea |
| 20-4 | H1 | 5310-012-0382 | H001-7025741 | | 120382 | WASHER, lock, med, S, cd- or zn-pltd, $\frac{3}{8}$ in | 1 | ea |
| 20-4 | | | | RWM-76 WO-118274 | | CAP, hanger bearing | 2 | ea |
| 20-4 | | | | RWM-75 WO-118273 | | CASE, hanger bearing | 1 | ea |
| 20-4 | | | | RWM-80 WO-118277 | | FITTING, grease, $\frac{1}{4}$ -28NF (hanger bearing) | 1 | ea |
| | | | G740-7994194 | TWM-74A WO-118272 | 7994194 | HANGER, ASSY | 1 | ea |
| | | | | | 701170 | Composed of: 2 BEARING 2 CAP 1 CASE 1 FITTING 2 SEAL 1 SHAFT | | |
| 20-4 | H1 | 5310-012-4634 | H001-4167721 | RWM-76 | 124634 | NUT, plain, hex, lt, s-fin, S, cd- or zn-pltd, $\frac{9}{16}$ -18NF-2 | 1 | ea |
| 20-4 | H1 | 5310-012-0898 | H001-7025831 | RWM-75 | 120898 | WASHER, lock, med, S, cd- or zn-pltd, $\frac{1}{16}$ in | 1 | ea |
| | | 2520-741-1681 | G740-7411681 | RWM-167B WO-801770 | 7411681 | HANGER, complete, assy | 1 | ea |
| | | | | | 123520 | Composed of: 1 BOLT | | |
| | | | | | 122279 | 1 BOLT | | |
| | | | | | 7994190 | 1 BRACE | | |
| | | | | | 7994194 | 1 HANGER | | |

357

2001.3

| | | | | | | | |
|------|---------------|--------------|-----------------------------------|---|---|---|----|
| 20-4 | | | RWM-SK109 WO-118213 | 7411690 124634 120898 120382 8332514 7994197 | 2 KEY 1 NUT 1 WASHER 1 WASHER 1 WASHER JOINT, slip, universal, assy..... | 1 | ea |
| | 2520-741-1677 | G740-7411677 | RWM-169B WO-801772 | 7411677 | JOINT, slip, universal, w/set SCREW, assy..... | 1 | ea |
| 20-4 | | | RWM-87 RWM-SK108 WO-118219 | 7994197 | Composed of: 1 JOINT 1 SCREW | | |
| | 2520-741-1685 | G740-7411685 | RWM-168B WO-801771 | 7994196 | JOINT, universal, assy..... | 1 | ea |
| | 5315-741-1646 | G740-7411646 | RWM-87 RWM-151 WO-118280 | 7411685 | JOINT, universal, w/set SCREW, assy..... | 3 | ea |
| 20-4 | 5315-741-1690 | G740-7411690 | RWM-87 RWM-88 WO-118211 | 7994196 | Composed of: 1 JOINT 2 SCREW | | |
| 20-4 | | | RWM-87 WO-118214 | 7411646 | KEY, hanger bearing shaft (superseded by KEY 7411690)..... | 2 | ea |
| 20-4 | 5330-741-1687 | G740-7411687 | WO-801868 | 7411690 | KEY (drive shaft (3), hanger bearing cap (2)) (super- sedes KEY 7411646) | 5 | ea |
| 20-4 | 5330-741-1950 | G740-7411950 | RWM-79 WO-118276 | 7411687 | SCREW, SET (universal slip joint (1), universal joint (6)) | 7 | ea |
| 20-4 | | | WO-119277 | 7411950 | SEAL, drive shaft..... | 1 | ea |
| | | G758-8332124 | WO-806009 | 8332124 | SEAL, grease, hanger bearing..... | 2 | ea |
| 20-4 | | | WO-119277 RWM-95A WO-118218 | 7411690 | SHAFT, drive, long..... | 1 | ea |
| | 2520-741-1953 | G740-7411953 | RWM-95 WO-801773 | 8332124 | SHAFT, drive, long, assy..... | 1 | ea |
| | | | RWM-95A | 7411953 | Composed of: 1 KEY 1 SHAFT | | |
| 20-4 | | | RWM-95A RWM-77 WO-118275 | 7411953 | SHAFT, drive, short..... | 1 | ea |
| | | | | 7411690 | SHAFT, drive, short, assy..... | 1 | ea |
| | | | | | Composed of: 2 KEY 1 SHAFT | | |
| | | | | | SHAFT, hanger bearing..... | 1 | ea |

| (1) ILLUSTRATION NO. | (2) REFERENCE SYMBOLS | (3) FEDERAL STOCK NO. | (4) ORDNANCE STOCK NO. | (5) MFR'S PART NO. | (6) ORDNANCE PART NO. | (7) DESCRIPTION | (8) QUANTITY INCORPORATED IN UNIT | (9) UNIT OF ISSUE |
|--|--------------------------|--------------------------|---------------------------|----------------------------------|--------------------------|---|--------------------------------------|----------------------|
| GROUP 20—WINCH AND POWER-TAKE-OFF—Continued | | | | | | | | |
| 2001.5—WINCH CONTROLS | | | | | | | | |
| 20-1 | | 5315-741-1954 | G740-7411954 | RWM-152 WO-118265 | 7411954 | KEY, clutch shifting lever..... | 1 | ea |
| 20-1 | | 2520-741-1955 | G740-7411955 | RWM-54 WO-118260 | 7411955 | LEVER, shifting, clutch..... | 1 | ea |
| 20-1 | | 2520-741-1956 | G740-7411956 | RWM-65 WO-118261 | 7411956 | PLUNGER, poppet (clutch shifting lever)..... | 2 | ea |
| 20-1 | | | | RWM-33 | | SCREW, set, $\frac{5}{16}$ -18NC x $\frac{1}{4}$ (poppet plunger (2), lever shaft (1)) | 3 | ea |
| 20-1 | | 2520-741-1958 | G740-7411958 | RWM-59 WO-118259 | 7411958 | SHAFT, clutch shifting yoke..... | 1 | ea |
| 20-1 | | 5340-741-1957 | G740-7411957 | RWM-66 WO-118262 | 7411957 | SPRING, poppet (clutch shifting lever)..... | 2 | ea |
| 20-1 | | 2520-741-1959 | G740-7411959 | RWM-58 WO-118258 | 7411959 | YOKE, shifting, clutch..... | 1 | ea |
| 20-1 | H1 | 019-2452 | H101-0192452 | | 192452 | BOLT, set, hex-socket, conc-pt, S, cd- or zn-pltd, $\frac{1}{4}$ -20NC x $\frac{3}{8}$ | 1 | ea |
| 2002.1—POWER-TAKE-OFF ASSEMBLY | | | | | | | | |
| 20-4 | | | | RWM-138 WO-118207 | | ADAPTER, gear housing..... | 1 | ea |
| 20-4 | | | | RWM-140 SP-S1103 WO-640632 | | NUT, hex, slotted, S, $\frac{5}{8}$ -18NC-3..... | 1 | ea |
| 20-4 | H1 | 010-3387 | H001-0811054 | | 103387 | PIN, cotter, split, S, $\frac{1}{8}$ x $1\frac{1}{2}$ | 1 | ea |
| 20-4 | | 5310-741-1972 | G740-7411972 | RWM-141 SP-872W WO-640622 | 7411972 | WASHER, FLAT, S, 0.68 ID, 1.28 OD, 0.125 thk..... | 1 | ea |
| 20-4 | H12 | | H012-1306020 | | 701170 | BEARING, ball, MIL-STD-CODE 111-02010-0000 (rad, SR, extra lt, non-loading groove, type 1, 0.7874 bore, 1.6535 OD, 0.4724 width) (output shaft) | 2 | ea |
| 20-4 | H12 | | H012-1303025 | | 700078 | BEARING, ball, MIL-STD-CODE 111-02502-0000 (rad, SR, lt, non-loading groove, 0.9843 bore, 2.0472 OD, 0.5906 width) (main drive gear) | 2 | ea |
| 20-4 | | 3020-741-1961 | G740-7411961 | RWM-135 WO-118202 | 7411961 | CHAIN, roller (main drive gear)..... | 1 | ea |
| 20-4 | | | | RWM-97 WO-118182 | | COVER, housing..... | 1 | ea |

| | | | | | | | | |
|---------|----|---------------|--------------|-----------------------|---------|---|---|----|
| 20-4 | H1 | 012-0854 | H001-5417601 | | 120854 | BOLT, mach, hex-hd, S, cd- or zn-pltd, ¼-20NC-3 x ⅝ | 8 | ea |
| 20-4 | H1 | 5310-012-0380 | H001-7025681 | | 120380 | WASHER, lock, med, S, cd- or zn-pltd, ¼ in | 8 | ea |
| 20-4 | | 2520-741-1962 | G740-7411962 | RWM-142 WO-118183 | 7411962 | GASKET, housing cover | 1 | ea |
| 20-4 | | 2520-741-1963 | G740-7411963 | RWM-117 WO-118184 | 7411963 | GEAR, main drive | 1 | ea |
| 20-4 | | 2520-741-1964 | G740-7411964 | RWM-119 WO-640343 | 7411964 | GEAR, sliding | 1 | ea |
| 20-4 | | | | RWM-96 WO-118181 | | HOUSING, power-take-off | 1 | ea |
| 20-4 | | 5315-741-1690 | G740-7411690 | RWM-88 WO-118211 | 7411690 | KEY, output shaft | 1 | ea |
| 20-4 | | | | RWM-133 WO-118201 | | KEY, sprocket | 2 | ea |
| 20-4 | H6 | 014-3934 | H106-0143934 | | 143934 | PLUG, PIPE, sq-hd, CI, cd- or zn-pltd, ⅜ in. (filler in. cover (1), drain in housing (1)) | 2 | ea |
| 20-4, 5 | | | G758-7994148 | RWM-105A WO-118212 | 7994148 | POWER-TAKE-OFF, w/o KEY, assy | 1 | ea |
| 20-4 | H1 | 012-0233 | H001-5420561 | | 120233 | BOLT, mach, hex-hd, S, cd- or zn-pltd, ⅜-16NC-3 x 1 | 5 | ea |
| 20-4 | H1 | 012-0930 | H001-7017685 | | 120930 | WASHER, lock, ext-teeth, ⅜ in | 5 | ea |
| 20-4 | | 2520-741-1965 | G740-7411965 | RWM-170B WO-801774 | 7411965 | POWER-TAKE-OFF, w/KEY, assy | 1 | ea |
| | | | | | 120233 | Composed of: | | |
| | | | | | 7411690 | 5 BOLT | | |
| | | | | | 7994148 | 1 KEY | | |
| | | | | | 120930 | 1 POWER-TAKE-OFF, assy | | |
| | | | | | 7411966 | 5 WASHER | | |
| 20-4 | | 5330-741-1966 | G740-7411966 | RWM-137 WO-118206 | 7411966 | SEAL, grease, main drive gear | 1 | ea |
| 20-4 | | 5330-741-1940 | G740-7411940 | RWM-515 WO-118205 | 7411940 | SEAL, grease, output shaft | 1 | ea |
| 20-4 | | 2520-741-1967 | G740-7411967 | RWM-134 WO-118203 | 7411967 | SHAFT, output | 1 | ea |
| 20-4 | | 2520-741-1970 | G740-7411970 | RWM-116 WO-118198 | 7411970 | SPACER, bearing, main drive gear | 1 | ea |
| 20-4 | | 2520-741-1971 | G740-7411971 | RWM-132 WO-118200 | 7411971 | SPROCKET | 2 | ea |
| 20-4 | H1 | 019-2452 | H101-0192452 | | 192452 | BOLT, set, hex-socket, cone-pt, S, cd- or zn-pltd, ¼-20-NC x ⅜ | 2 | ea |
| | | | | | | 2002.5 - POWER-TAKE-OFF CONTROLS | | |
| 20-4 | | 2520-741-1974 | G740-7411974 | RWM-123 WO-640627 | 7411974 | BALL, poppet (shifter shaft) | 1 | ea |
| 20-4 | | 2520-737-5153 | G740-7375153 | WO-801848 | 7375153 | BOOT, shift lever, outer | 1 | ea |
| 20-4 | | | | WO-804765 | | BRACKET, latch | 1 | ea |

2002.5

360

| (1) ILLUSTRATION NO. | (2) REFERENCE SYMBOLS | (3) FEDERAL STOCK NO. | (4) ORDNANCE STOCK NO. | (5) MFR'S PART NO. | (6) ORDNANCE PART NO. | (7) DESCRIPTION | (8) QUANTITY INCORPORATED IN UNIT | (9) UNIT OF ISSUE |
|--|--------------------------|--------------------------|---------------------------|----------------------------------|------------------------------|--|--------------------------------------|----------------------|
| GROUP 20—WINCH AND POWER-TAKE-OFF—Continued | | | | | | | | |
| 2002.5—POWER-TAKE-OFF CONTROLS—Continued | | | | | | | | |
| 20-4 | | 2520-741-1975 | G740-7411975 | RWM-126 WO-640624 | 7411975 | COVER, LEVER, SHIFT, grease retainer..... | 1 | ea |
| 20-4 | | | | RWM-129 SP-920D WO-640623 | | SCREW, ext-teeth-lock washer, rd-hd, S, No. 10-32NF-2 x 3/8 | 4 | ea |
| 20-4 | | | G503-7696491 | RWM-128 WO-A971 | 7696491 | KNOB, shift lever..... | 1 | ea |
| 20-4 | | 2520-741-1976 | G740-7411976 | WO-804764 | 7411976 | LATCH, winch power-take-off..... | 1 | ea |
| 20-4 | | | G740-8329889 | WO-804611 | 8329889 | LATCH, winch power-take-off, assy..... | 1 | ea |
| | | | | WO-804765 | | Composed of: 1 BRACKET | | |
| 20-4 | H1 | 5305-016-1901 | H101-0161901 | | 7411976 7411980 161901 | 1 LATCH 1 PIN SCREW, tapping, thread forming, recess, pan-hd, gimlet-pt, sh-met-thd, S, cd- or zn-pltd, No. 10 x 5/8 | 4 | ea |
| 20-4 | | 2520-741-1977 | G740-7411977 | RWM-121 WO-640659 | 7411977 | LEVER, shift..... | 1 | ea |
| 20-4 | | 5315-741-1980 | G740-7411980 | WO-804041 | 7411980 | PIN, latch, winch power-take-off..... | 1 | ea |
| | | 5315-741-1979 | G740-7411979 | RWM-118 WO-640629 | 7411979 | PIN, shift lever (shifter shaft end) (superseded by PIN 137486) | 1 | ea |
| | | | | | 137486 | PIN, straight, plain finish 7/32 x 1/2 (supersedes PIN 7411979) | 1 | ea |
| 20-4 | H1 | 011-7877 | H101-0117877 | | 117877 | PIN, straight, headless, pivot, shift lever..... | 1 | ea |
| 20-4 | | | | RWM-130 SP-31P10 WO-640626 | | PLATE, shift lever..... | 1 | ea |
| 20-4 | | 5330-741-1981 | G740-7411981 | RWM-127 WO-640625 | 7411981 | RETAINER, grease, shift lever..... | 1 | ea |
| 20-4 | | 2510-736-1994 | G503-7361994 | WO-646073 | 7361994 | SEAL, shift lever..... | 1 | ea |
| | | 2520-741-1982 | G740-7411982 | RWM-124 WO-640619 | 7411982 | SHAFT, shifter (peened)..... | 1 | ea |
| 20-4 | | | | SP-6510X WO-640617 | | SHAFT, shifter w/YOKE, assy (peened)..... | 1 | ea |
| | | | | | 137486 7411982 7411973 | Composed of: 1 PIN 1 SHAFT 1 YOKE | | |

| | | | | | | | | |
|------------------------------------|----|---------------|--------------|----------------------|---------|--|---|----|
| 20-4 | | 5340-741-1983 | G740-7411983 | RWM-122 WO-640628 | 7411983 | SPRING, poppet (shifter shaft)..... | 1 | ea |
| | | 2520-741-1973 | G740-7411973 | RWM-120 WO-640618 | 7411973 | YOKE, sliding gear (peened)..... | 1 | ea |
| GROUP 21—BUMPERS AND GUARDS | | | | | | | | |
| 2101—BUMPERS AND GUARDS | | | | | | | | |
| 15-1 | | 2510-737-2818 | G740-7372818 | WO-801386 | 7372818 | BAR, bumper (front) (superseded by BAR 8331831)..... | 1 | ea |
| | H1 | | G758-8331831 | WO-808969 | 8331831 | BAR, bumper (front) (supersedes BAR 7372818)..... | 1 | ea |
| | | | H101-0271193 | | 271193 | NUT, hex, lt, ext-teeth lock washer, S, cd- or zn-pltd, 3/8-24NF-2B | 6 | ea |
| 18-4 | H1 | 012-0758 | H001-5421241 | | 120758 | SCREW, cap, hex-hd, S, cd- or zn-pltd, 3/8-24NF-3 x 7/8 | 6 | ea |
| | | 2510-737-2819 | G740-7372819 | WO-800078 | 7372819 | BUMPERETTE, rear..... | 2 | ea |
| | H1 | 012-0371 | H001-4167681 | | 120371 | NUT, hex, lt, s-fin, S, cd- or zn-pltd, 1/2-20NF-2..... | 4 | ea |
| | H1 | 012-3605 | H101-0123605 | | 123605 | SCREW, cap, hex-hd, S, cd- or zn-pltd, 1/2-20NF-3 x 1 | 4 | ea |
| | H1 | 5310-012-0384 | H001-7025801 | | 120384 | WASHER, lock, med, S, cd- or zn-pltd, 1/2 in..... | 4 | ea |
| | | 6220-737-2820 | G740-7372820 | WO-800390 | 7372820 | GUARD, blackout driving light, w/SUPPORT (welded)..... | 1 | ea |
| | H1 | 018-7993 | H101-0187993 | | 187993 | BOLT, ext-teeth lock washer, hex-hd, S, cd- or zn-pltd, 5/16-18NC-2 x 3/4 | 1 | ea |
| | H1 | 042-3560 | H101-0423560 | | 423560 | BOLT, INTEGRAL LOCK WASHER, ext-teeth lock washer, hex-hd, S, cd- or zn-pltd, 5/16-18NC-2 x 1/2 | 2 | ea |
| | | | G758-8329975 | WO-680450 | 8329975 | GUARD, radiator w/DEFLECTORS, HINGES, and hood LINER, assy (used on vehicles through serial No. 60406) | 1 | ea |
| 05-1 | | 5305-737-2886 | G740-7372886 | WO-673468 | 7372886 | SCREW, int-teeth lock washer, hex-hd, S, cd- or zn-pltd, 5/16-18NC x 7/8 | 6 | ea |
| 18-1 | | | | WO-684569 | | GUARD, radiator, w/DEFLECTORS, HINGES, and hood LINER, assy (used on vehicles after serial No. 60406) | 1 | ea |
| 05-1 | H1 | | H101-0442830 | | 442830 | NUT, hex, "Huglock," alloy-S, cd- or zn-pltd, 7/16- 20NF | 1 | ea |
| 05-1 | H1 | | H001-5423121 | | 124139 | SCREW, cap, hex-hd, S, cd- or zn-pltd, 7/16-20NF-3 x 2 1/4 | 1 | ea |
| 05-1 | | | | WO-683574 | | SPACER, S, cd- or zn-pltd, 3/4 OD, 1.120 lg..... | 1 | ea |
| 05-1 | | | | WO-683576 | | WASHER, flat, ru, 2 5/32 ID, 2.000 OD, 0.560 thk..... | 2 | ea |
| 05-1 | | | | WO-683575 | | WASHER, flat, S, cd- or zn-pltd, 1 5/32 ID, 2.000 OD, 0.120 thk | 1 | ea |
| 05-1 | H1 | 5310-012-0395 | H001-7043771 | | 120395 | WASHER, flat, S, cd- or zn-pltd, 1 5/32 ID, 5 9/64 OD, 0.065 thk | 1 | ea |
| | | | | WO-680409 | 8677600 | GUARD, radiator, w/RETAINERS and NUTS, assy (use through vehicles serial No. 60406) | 1 | ea |
| 05-1 | | | | WO-684570 | | GUARD, radiator, w/RETAINERS and NUTS, assy (use after vehicles serial No. 60406) | 1 | ea |

2101

362

| (1) ILLUSTRATION NO. | (2) REFERENCE SYMBOLS | (3) FEDERAL STOCK NO. | (4) ORDNANCE STOCK NO. | (5) MFR'S PART NO. | (6) ORDNANCE PART NO. | (7) DESCRIPTION | (8) QUANTITY INCORPORATED IN UNIT | (9) UNIT OF ISSUE |
|-------------------------|--------------------------|--------------------------|---------------------------|-----------------------|--------------------------|---|--------------------------------------|----------------------|
| | | | | | | GROUP 21—BUMPERS AND GUARDS—Continued | | |
| | | | | | | 2101—BUMPERS AND GUARDS—Continued | | |
| | | | | WO-680292 | | GUARD, tail light and trailer connection..... | 1 | ea |
| | | | | ONB-SN2113 | 8676969 | NUT, weld, S, 1/4-20NC (tail light and trailer connection guard) | 5 | ea |
| | | | G758-8329976 | WO-674350 | | | | |
| | | | | WO-680291 | 8329976 | GUARD, tail light and trailer connection, w/weld NUTS (welded) | 1 | ea |
| | H1 | | H101-0425380 | | 425380 | BOLT, int-teeth lock washer, hex-hd, S, cd- or zn-pltd, 1/4-20NC-2 x 5/8 in. | 5 | ea |
| | | 5340-769-7592 | G740-7697592 | WO-673621 | 7697592 | HINGE, panel, radiator guard (use up to vehicles serial No. 60406) | 2 | ea |
| | | 5305-769-7446 | G740-7697446 | WO-673501 | 7697446 | SCREW, lock washer, hex-hd, S, cd- or zn-pltd, 3/8-16NC x 1 | 4 | ea |
| 05-1 | | | | WO-680420 | | LINER, hood, radiator guard..... | 1 | ea |
| 05-1 | H1 | | | | 113454 | RIVET, split, oval-hd, S, blk-enmld, 9/4 x 1/16, 5/16 hd dia | 13 | ea |
| | | | | WO-680679 | | NUT, clinch, S, No. 10-24NC (head light mounting rings) | 16 | ea |
| | | | | ONB-SN2113 | 8676969 | NUT, SPOTWELD, S, 1/2-20NC (radiator guard)..... | 4 | ea |
| | | | | WO-674350 | | | | |
| | | | | WO-681439 | 8393232 | PIN, hinge, radiator guard (used through vehicle serial No. 60406) | 2 | ea |
| | | | G758-8329977 | WO-681443 | 8329977 | PIN, hinge, radiator guard, w/BRACKET, left (welded) (used through vehicle serial No. 60406) | 1 | ea |
| | | | G758 8329979 | WO-681444 | 8329979 | PIN, hinge, radiator guard, w/BRACKET, right (welded) (used through vehicle serial No. 60406) | 1 | ea |
| | H1 | | H101-9409102 | | 7697550 | BOLT, MACHINE, assembled washer, hex-hd, split lock washer, S, cd- or zn-pltd, 5/16-24UNF-2A x 3/4 | 4 | ea |
| | | | | WO-675141 | | PLATE, tapping, two-holes, 3/8-16NC-2 (radiator guard hinge) (used through vehicles serial No. 60406) | 2 | ea |
| 18-6 | | | | WO-681039 | 8677566 | RAIL, hand, safety, front passenger seat..... | 1 | ea |
| 18-6 | H1 | | H101-0451976 | | 451976 | SCREW, lock washer, hex-hd, S, cd- or zn-pltd, 3/8-16NC-3 x 3/4 | 2 | ea |
| | | 2510-769-7548 | G740-7697548 | WO-A3549 | 7697548 | RETAINER, sq-nut, 5/16 in. (radiator guard)..... | 2 | ea |
| | H1 | 012-0399 | H001-4139781 | | 120399 | NUT, mach screw, sq, S, cd- or zn-pltd, 5/16-18NC-2.... | 2 | ea |
| | | | | WO-681347 | | RETAINER, tapping plate, radiator guard hinge, left (used through vehicles serial No. 60406) | 1 | ea |
| | | | | WO-681348 | | RETAINER, tapping plate, radiator guard hinge, right (used through vehicles serial No. 60406) | 1 | ea |

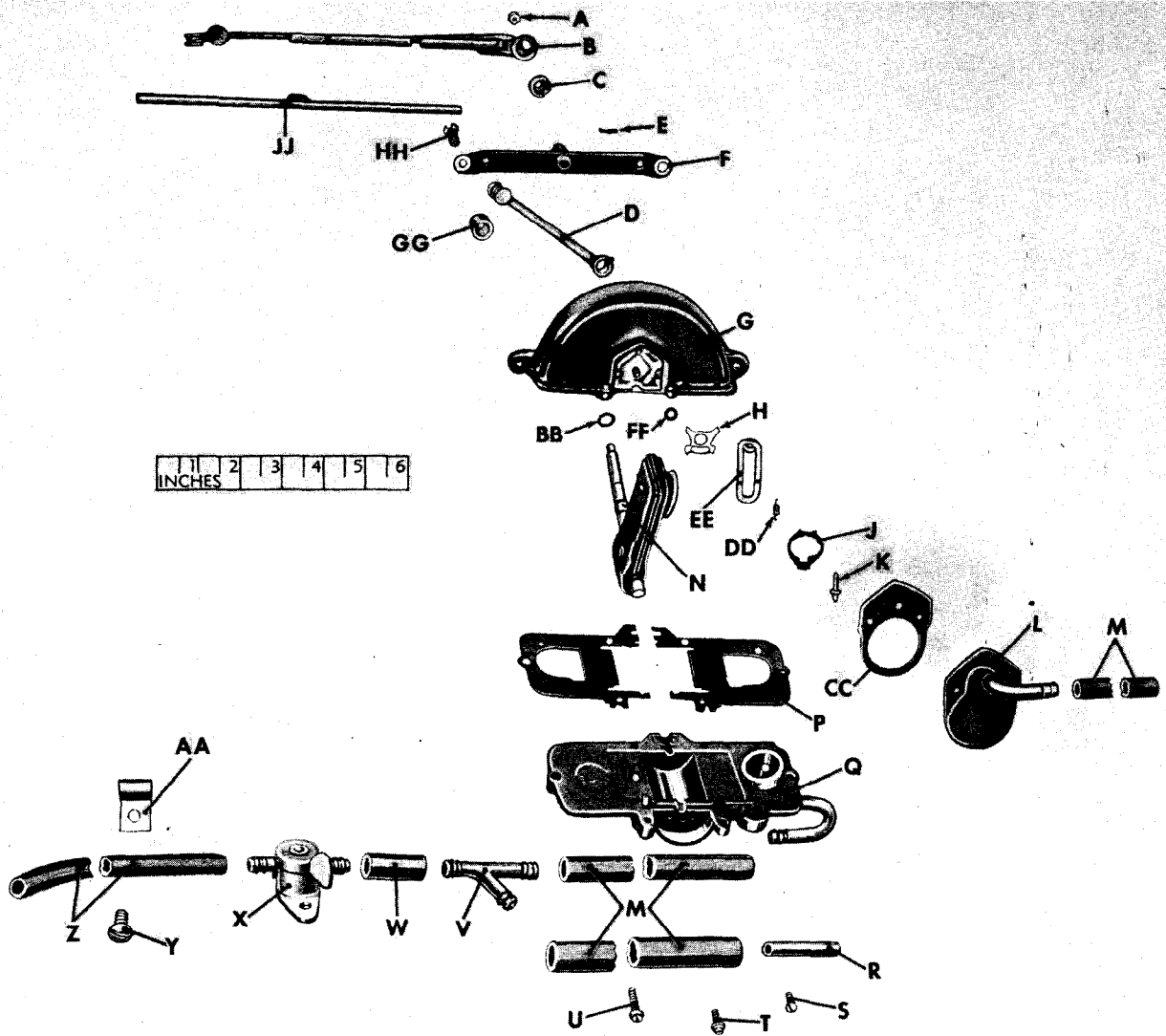

KEY ITEM
 A—NUT
 B—ARM
 C—DRIVER
 D—HANDLE, ASSY
 E—PIN
 F—PLATE
 G—HOUSING
 H—VALVE
 J—YOKE
 K—KICKER
 L—COVER
 M—TUBE
 N—PADDLE, ASSY
 P—GASKET
 Q—COVER
 R—TUBE
 S—SCREW

PART NO
 7058965
 500810
 7372262
 TRI-809-14
 TRI-87453
 TRI-82812-41
 TRI-86520-1
 TRI-2631-1
 A327340
 TRI-2618-17
 TRI-8896-1
 WO-674651
 TRI-P87350-1J
 TRI-8735-2
 TRI-86521-3
 WO-677153
 TRI-1863-8

KEY ITEM
 T—SCREW
 U—SCREW
 V—TEE
 W—TUBE
 X—VALVE
 Y—SCREW
 Z—TUBE
 AA—CLIP
 BB—GASKET
 CC—GASKET
 DD—SPRING
 EE—RETAINER
 FF—WASHER
 GG—SPACER
 HH—SCREW
 JJ—BLADE

PART NO
 TRI-1900
 TRI-1900-1R
 7099460
 8677266
 8329996
 163600
 8677565
 WO-673622
 TRI-F1140
 TRI-8894-3
 A327341
 5327338
 A327342
 TRI-1895
 TRI-1727-28
 500813

NOTE: ALL PARTS LISTED ARE IN GROUP 2202

RA PD 367162

Figure 22-1. Windshield wiper motor and related parts—exploded view

2201

| (1) ILLUSTRATION NO. | (2) REFER- ENCE SYMBOLS | (3) FEDERAL STOCK NO. | (4) ORDNANCE STOCK NO. | (5) MFR'S PART NO. | (6) ORDNANCE PART NO. | (7) DESCRIPTION | (8) QUANTITY INCOR- PORATED IN UNIT | (9) UNIT OF ISSUE |
|--|----------------------------------|-----------------------------|------------------------------|-----------------------|-----------------------------|--|---|----------------------------|
| GROUP 22—MISCELLANEOUS ACCESSORIES | | | | | | | | |
| 2201—CANVAS ITEMS, BOWS, AND CURTAINS | | | | | | | | |
| | | | | WO-684980 | | BOARD, stabilizer (front to right rear top bow) (M170) | 1 | ea |
| | H1 | 012-8417 | H001-3057051 | | 128417 | BOLT, SQUARE NECK, step, S, cd- or zn-pltd, $\frac{5}{16}$ -18NC-2 x $\frac{1}{8}$ | 4 | ea |
| | H1 | 012-0376 | H001-4167541 | | 120376 | NUT, PLAIN, HEXAGON, lt, s-fin, S, cd- or zn-pltd $\frac{5}{16}$ -18NC-2 | 4 | ea |
| | H1 | 5310-044-6363 | H101-0446363 | | 446363 | WASHER, FLAT, S, cd- or zn-pltd, $\frac{3}{8}$ ID, $\frac{7}{8}$ OD, 0.083 thk | 4 | ea |
| | | 2510-737-2889 | G740-7372889 | WO-685716 | | BOARD, stabilizer (windshield to front top bow) (M170) | 1 | ea |
| | | | | WO-673803 | 7372889 | BOW, top, assy (includes front and rear) (M38A1) | 1 | ea |
| 18-5 | | | | WO-683000 | | BOW, top, center (M170) | 1 | ea |
| 18-5 | | | | WO-684996 | | BOW, top, center front (welded) (M170) | 1 | ea |
| 18-5 | | | | WO-684988 | | BOW, top center rear (welded) (M170) | 1 | ea |
| | | 2510-737-2890 | G740-7372890 | WO-673791 | 7372890 | BOW, top, front, assy (M38A1) | 1 | ea |
| | H1 | 010-4099 | H001-0924222 | | 104099 | RIVET, b-hd, S, $\frac{5}{16}$ x 1 | 2 | ea |
| | H1 | 5310-050-2246 | H101-0502246 | | 502246 | WASHER, flat, S, cd- or zn-pltd, $\frac{11}{32}$ ID, 1 OD, 0.094 thk | 2 | ea |
| | | 2510-737-2891 | G740-7372891 | WO-673794 | 7372891 | BOW, top, rear (welded) (includes top bow PIVOT) (M38A1) | 1 | ea |
| 18-5 | | | | WO-683023 | | BOW, top side front, left (welded) (M170) | 1 | ea |
| 18-5 | | | | WO-683024 | | BOW, top side front, right (welded) (M170) | 1 | ea |
| 18-5 | | | | WO-683003 | | BOW, top side rear, left (welded) (M170) | 1 | ea |
| 18-5 | | | | WO-685000 | | BOW, top side rear, right (complete) (welded) (M170) | 1 | ea |
| | H1 | | H101-0451975 | | 451975 | SCREW, lock washer, sltd-hex-hd, S, cd- or zn-pltd, $\frac{5}{16}$ -18NC-3 x $\frac{3}{4}$ | 2 | ea |
| | H1 | 5310-012-0393 | H001-7043711 | | 120393 | WASHER, FLAT, S, cd- or zn-pltd, $\frac{11}{32}$ ID, $\frac{11}{16}$ OD, 0.065 thk | 2 | ea |
| | H2 | | H002-0585861 | | 585861 | BUCKLE, tongueless, web strap, S, cd- or zn-pltd, 1 in. (curtain stowage (10), top strap (11) (M170) | 21 | ea |
| | H2 | | H002-0543496 | | 543496 | BUCKLE, web strap, S, cd- or zn-pltd, 1 $\frac{1}{2}$ in. (door stowage strap) (M170) | 2 | ea |
| | | 2540-737-5324 | G740-7375324 | WO-674622 | 7375324 | CHAIN, w/RING and retaining PIN, assy (top rail) (used on vehicles thru serial No. 83545) (M38A1) | 2 | ea |
| | | | | | 42-C-16600 | Composed of: 2 CHAIN 2 PIN 4 RING | | |
| | | | | WO-674621 | | | | |
| | | | | WO-673774 | | | | |

364

| | | | | | | | |
|----|---------------|--------------|-----------|------------|--|----|----|
| H8 | | H008-0819985 | | 42-C-16600 | CHAIN, weldless, safety, S, 0.018 in., coml No. 00 (13 links, 6 in. lg) (thumb screw (2), retaining pin (2)) (used on vehicles through serial No. 83545) | 4 | ea |
| | | G758-8329754 | WO-680320 | 8329754 | COVER, TOP, assy (includes DECK, rear CURTAIN, and STRAPS) (M38A1) | 1 | ea |
| | | | WO-685536 | | COVER, top, assy (includes top DECK) (M170) | 1 | ea |
| | | | WO-680351 | | CURTAIN, door, left, assy (M170) | 1 | ea |
| | | | WO-684278 | | CURTAIN, door, right, assy (M170) | 1 | ea |
| | | | WO-680940 | | CURTAIN, rear, assy (includes LIGHT, STRAPS, and FASTENERS) (M38A1) | 1 | ea |
| | | | WO-685560 | | CURTAIN, side, left, assy (M170) | 1 | ea |
| | | | WO-685555 | | CURTAIN, side, right, assy (M170) | 1 | ea |
| | | | WO-685865 | | DOOR, left, assy (includes TRIM and FRAME complete (M170)) | 1 | ea |
| | | | WO-684258 | | DOOR, right, assy (includes TRIM and FRAME complete (M170)) | 1 | ea |
| | | | WO-680330 | | EXTENSION, top deck header, front, assy | 1 | ea |
| | | | WO-685537 | | EXTENSION, top deck rear, assy (M170) | 1 | ea |
| | | | WO-685539 | | EXTENSION, top deck side, left (M170) | 1 | ea |
| | | | WO-685540 | | EXTENSION, top deck side, right (M170) | 1 | ea |
| H2 | | H102-0426687 | | 426687 | EYELET, large turn button fastener, br, black, $\frac{3}{16}$ in. lg prong (front top bow flat (6), top deck (22)) (M38A1) | 30 | ea |
| H2 | | H102-0426687 | | 426687 | EYELET, large turn button fastener br, black, $\frac{3}{16}$ lg prong (M170) | 62 | ea |
| | | | WO-674176 | | FLAP, canvas, center bow, top (M38A1) | 3 | ea |
| | | | WO-680333 | | FLAP, canvas, wind break, deck side, left, assy (M38A1) | 1 | ea |
| | | | WO-680334 | | FLAP, canvas, wind break, deck side, right, assy (M38A1) | 1 | ea |
| | | | WO-685545 | | FLAP, deck side wind break, left, assy (M170) | 1 | ea |
| | | | WO-685544 | | FLAP, deck side wind break, right, assy (M170) | 1 | ea |
| | | | WO-686135 | | HANDLE, door, w/STUD (welded) (M170) | 2 | ea |
| | | | WO-680503 | | HINGE, door (M170) | 2 | ea |
| | | | WO-670953 | 8676953 | LOOP, footman (auxiliary litter stowage) (M170) | 1 | ea |
| H2 | | H002-8328423 | | 8328423 | LOOP, footman (front center bow (2), front right side bow (1), right side bow (1)) (M170) | 4 | ea |
| | | | | 163470 | SCREW, cross-recess-oval-hd, S, ed- or zn-pltd, No. 10 (0.190)-16 x $\frac{5}{8}$ | 8 | ea |
| | | | WO-673782 | | NUT, weld, S, $\frac{3}{8}$ -16NC (rear top bow socket) (used on vehicles through serial No. 83545) (M38A1) | 2 | ea |
| | 2510-736-9951 | G740-7369951 | WO-673158 | 7369951 | PANE, clear, flexible vinyl, 0.040 thk, (rear curtain) (M38A1) | 1 | ea |
| | 2510-734-8325 | G740-7348525 | WO-674621 | 7348525 | PIN, retaining, chain, S, 0.091 dia 2 $\frac{1}{2}$ dev lg (M38A1) | 2 | ea |
| | | | WO-673797 | | PIVOT, front top bow (M38A1) | 2 | ea |
| | | | WO-677417 | | PLATE, latch, left (M170) | 1 | ea |
| | | | WO-677418 | | PLATE, latch, right (M170) | 1 | ea |
| | | | WO-677412 | | PLATE, rub (M170) | 2 | ea |
| | | | WO-683991 | | RAIL, top left, assy (M170) | 1 | ea |
| | | | WO-683992 | | RAIL, top right, assy (M170) | 1 | ea |

| (1) ILLUSTRATION NO. | (2) REFER- ENCE SYMBOLS | (3) FEDERAL STOCK NO. | (4) ORDNANCE STOCK NO. | (5) MFR'S PART NO. | (6) ORDNANCE PART NO. | (7) DESCRIPTION | (8) QUANTITY INCOR- PORATED IN UNIT | (9) UNIT OF ISSUE |
|-------------------------|----------------------------------|-----------------------------|------------------------------|-----------------------|-----------------------------|--|---|----------------------------|
| | | | | | | GROUP 22—MISCELLANEOUS ACCESSORIES—Continued | | |
| | | | | | | 2201—CANVAS ITEMS, BOWS, AND CURTAINS | | |
| | | | | | | —Continued | | |
| | | | | WO-680437 | | RAIL, top (welded) (includes BRACKET) (M38A1)..... | 2 | ea |
| | | | | WO-673774 | | RING, thumb screw chain, S, 0.047 dia, 3 1/8 dev-lg (thumb screw (2), retaining pin (4)) (used on vehicles through serial No. 83545) (M38A1) | 8 | ea |
| | | | | WO-685453 | | ROD, front side curtain, left (M170)..... | 1 | ea |
| | | | | WO-682884 | | ROD, front side curtain, right (M170)..... | 1 | ea |
| | | | | WO-674789 | 8677315 | SCREW, thumb, MCI, cd- or zn-pltd, 3/8-16NC (used on vehicles through serial No. 83545) (M38A1) | 2 | ea |
| | | 5305-769-7593 | G740-7697593 | WO-674790 | 7697593 | SCREW, thumb, w/CHAIN and RING, assy (used on vehicles through serial No. 83545) (M38A1) | 2 | ea |
| | | | | | 42-C-16600 | Composed of: 2 CHAIN 4 RING | | |
| | | | | WO-673774 | | 2 SCREW | | |
| | | | | WO-674789 | 8677315 | SOCKET, rear top bow (superseded by SOCKET WO-684239) (M38A1) | 2 | ea |
| | | | | WO-673777 | | SOCKET, rear top bow (supersedes SOCKET WO- 673777) (M38A1) | 2 | ea |
| | | | | WO-684239 | | SCREW, ext-teeth lock washer, hex-hd, S, cd- or zn- pltd, 5/16-18NC-2 x 3/4 in. (superseded by SCREW 425388) | 6 | ea |
| | | 5305-769-7440 | G740-7697440 | WO-673597 | 7697440 | SCREW, int-teeth lock washer, hex-hd, header-pt, S, cd- or zn-pltd, 5/16-18NC-2 x 5/8 (supersedes SCREW 7697440) | 6 | ea |
| | H1 | | H101-0425388 | | 425388 | SOCKET, rear top bow w/weld NUT (welded) (used on vehicles through serial No. 83545) (M38A1) | 2 | ea |
| | | 2510-737-2898 | G740-7372898 | WO-673771 | 7372898 | SOCKET, side curtain rod w/door HINGE (welded) (M170) | 4 | ea |
| | | | | WO-682803 | | STRAP, stowage, door (M170)..... | 2 | ea |
| | | | | WO-685910 | | Composed of: 1 BUCKLE 1 STRAP | | |
| | | | | WO-685902 | 543496 | 1 TIP | | |
| | | | | WO-686145 | 549605 | STRAP, w/BUCKLE, assy (curtain stowage) (M170)..... | 10 | ea |
| | | | | WO-686146 | 585861 | Composed of: 1 BUCKLE 1 STRAP | | |

| | | | | | | | |
|----|---------------|--------------|---------------|---------|--|----|----|
| | | | WO-686143 | | STRAP, w/end TIP, assy (curtain stowage) (M170)..... | 10 | ea |
| | | | WO-686144 | | Composed of: | | |
| | | | WO-A2602 | | 1 STRAP | | |
| | | | WO-671968 | 7697594 | 1 TIP | | |
| | 5340-769-7594 | G740-7697594 | | | STRAP, w/BUCKLE, assy (top strap)..... | 11 | ea |
| | | | | | Composed of: | | |
| | | | WO-671979 | 585861 | 1 BUCKLE | | |
| | | | WO-A2602 | | 1 STRAP | | |
| | | | WO-685902 | | 1 TIP | | |
| | | | | | STRAP, web, 1½ in. wd (111 in. approx dev lg) (door stowage) (M170) | 2 | ea |
| | | | WO-686146 | | STRAP, web, 1 in., wide (curtain stowage) (M170)..... | 10 | ea |
| | | | WO-686144 | | STRAP, web, 1 in. wide, 22 in. lg (curtain stowage) (M170) | 10 | ea |
| | | | WO-671979 | | STRAP, web, 1 in. wide (21½ in. dev-lg) (top strap)..... | 11 | ea |
| | | | UC-78318-K352 | | STUD, large turn button fastener, dble, br, black, eyelet base (top hold-down (6), top deck side reinforcement (16, front top bow flap (6))) (M38A1) | 28 | ea |
| | | | WO-663596 | | | | |
| H2 | | H002-7697417 | | 7697417 | STUD, large turn button fastener, dble, br, black eyelet base (M170) | 42 | ea |
| | | | UC-78317 | | STUD, large turn button fastener, sgle, br, black, eyelet base (top deck) | 2 | ea |
| | | | WO-663595 | | STUD, single turn button (door curtain to body) (M170) | 8 | ea |
| | | | WO-680686 | | NUT, hex, ext-teeth lock washer, S, cd- or zn-pltd, No. 10-32NC | 8 | ea |
| | | | WO-680769 | | | | |
| H2 | | H002-0549605 | | 549605 | TIP, end, web strap, S, 1½ in. (door stowage strap) (M170) | 2 | ea |
| | | | N&J-1 | | TIP, strap end, S, 1 in. (top strap (11) curtain stowage (10)) (M170) | 21 | ea |
| | | | WO-A2602 | | | | |
| | 5325-769-7418 | G740-7697418 | UC-78502 | 7697418 | WASHER, curtain, large turn buckle fastener eyelet, bezel, br, black 0.240 ID, wd 0.510, 0.780 lg (top hold-down (6), top deck (2), top deck side reinforcement (16), center bow flap (6)) (M38A1) | 30 | ea |
| | | | WO-663597 | | | | |
| | | G740-7697418 | WO-663597 | 7697418 | WASHER, curtain, large turn button fastener eyelet, bezel, br, black 0.240 ID, 0.510 wd 0.780 lg (M170) | 44 | ea |
| H2 | | H102-0426686 | | 426686 | WASHER, large turn button fastener eyelet, br, black (front top bow strap (2), top deck (22), front top bow flap (6)) (M38A1) | 30 | ea |
| | | | | | | | |
| H2 | | H102-0426686 | | 426686 | WASHER, large turn button fastener eyelet, br, black (M170) | 62 | ea |
| | | | WO-686152 | | ZIPPER, 33½ in. lg (M170) | 1 | ea |
| | | | G740-7697595 | 7697595 | ZIPPER, hand opening in left door, 16 in. (superseded by ZIPPER 538442) (M170) | 1 | ea |
| | | | WO-674004 | | | | |
| H2 | | H002-0212606 | | 538442 | ZIPPER, slide, conventional, non-separating, hv, sgle action, open top, closed bottom, non-locking sgle pull non-rvrs slider, 16 in. (supersedes ZIPPER 7697595) (M170) | 1 | ea |

| (1) ILLUSTRATION NO. | (2) REFERENCE SYMBOLS | (3) FEDERAL STOCK NO. | (4) ORDNANCE STOCK NO. | (5) MFR'S PART NO. | (6) ORDNANCE PART NO. | (7) DESCRIPTION | (8) QUANTITY INCORPORATED IN UNIT | (9) UNIT OF ISSUE |
|--|--------------------------|--------------------------|---------------------------|------------------------|--------------------------|--|--------------------------------------|----------------------|
| GROUP 22—MISCELLANEOUS ACCESSORIES—Continued | | | | | | | | |
| 2202—MIRRORS, REFLECTORS, AND WINDSHIELD WIPERS | | | | | | | | |
| | H2 | 2540-054-7250 | H002-0547250 | | 547250 | ARM, adjustable, outside rear view mirror, assy (8 to 11 in.) Composed of: 1 ARM 1 ARM 1 CLAMP 1 NUT 1 SCREW | 1 | ea |
| | | | | WO-118139 | | ARM, extension, mirror (adjustable) | 1 | ea |
| | | | | WO-118140 | | ARM, extension, mirror (fixed) | 1 | ea |
| | H1 | 012-0647 | H001-5421261 | | 120647 | BOLT, MACHINE, cap, hex-hd, S, cd- or zn-pltd, 3/8-24NF-3 x 1 | 1 | ea |
| | H1 | 012-0369 | H001-4167601 | | 120369 | NUT, PLAIN, HEXAGON, lt, s-fin, S, cd- or zn-pltd, 3/8-24NF-2 | 1 | ea |
| | | | | WO-118146 | | WASHER, fiber, 3/8 ID, 1/32 thk | 2 | ea |
| 22-1 | H17 | 5310-012-0381 | H001-7023741 | | 120381 | WASHER, lock, lt, S, cd- or zn-pltd, 3/8 in | 1 | ea |
| 22-1 | | 5310-705-8965 | G509-7058965 | TRI-75072 WO-673569 | 500810 7058965 | ARM, windshield wiper, adjustable, 7 1/2 to 12 in | 2 | ea |
| 22-1 | H17 | | H017-0500813 | | 500813 | NUT, PLAIN, CAP, blind, S, No. 10-32NF-2 (windshield wiper arm to shaft) | 2 | ea |
| | | 2540-737-5190 | G740-7375190 | WO-118143 | 7375190 | BLADE, windshield wiper, 9 in. lg | 2 | ea |
| | | 5325-737-1195 | G503-7371195 | WO-347002 | 7371195 | BRACKET, mounting, rear view mirror | 2 | ea |
| | | | | WO-118141 | | BUSHING, ru, split, 1/16 ID (windshield wiper tube hole in instrument panel) (used on vehicles through serial No. 74272) | 1 | ea |
| | | | | WO-118141 | | CLAMP, collar, S, 0.771 ID, 1/16 OD (rear view mirror extension arm) | 1 | ea |
| | | | | WO-A11862 | | NUT, jam, hex, thin, S, 1/4-28NF | 1 | ea |
| | | | | WO-118142 | | SCREW, set, sq-hd, cup-pt, S, 1/4-28NF x 1/2 | 1 | ea |
| | | | | WO-118149 | | CLAMP, pivot, rear view mirror | 1 | ea |
| | H1 | 012-0677 | H001-5421341 | | 120677 | BOLT, MACHINE, cap, hex-hd, S, cd- or zn-pltd, 3/8-24NF-3 x 1 1/2 | 1 | ea |
| | H1 | 022-5831 | H001-4027541 | | 225831 | NUT, PLAIN, HEXAGON, reg, s-fin, S, cd- or zn-pltd, 3/8-24NF-2 | 1 | ea |
| | | | | WO-118146 | | WASHER, fibre, 3/8 ID, 1/32 thk | 2 | ea |
| | H1 | 5310-012-0381 | H001-7023741 | | 120381 | WASHER, lock, lt, S, cd- or zn-pltd, 3/8 in | 1 | ea |

| | | | | | | | | |
|------|----|---------------|--------------|-------------|------------|--|---|----|
| 22-1 | | | | WO-673622 | | CLIP, closed, S, zn-pltd, 1/4 OD tube, hole for No. 10 screw (windshield wiper hose) | 5 | ea |
| 22-1 | H1 | | | | 163600 | SCREW, tapping, cross-recess-pan-hd, conical pilot-pt, sh-met-thd, S, cd- or zn-pltd, No. 10 (0.186) x 1/2 | 5 | ea |
| 03-8 | | 350-5667 | G184-5229645 | WO-633948 | 5229645 | CLIP, closed, S, 1/4 OD tube, hole for 3/8 screw (vacuum pump to tee tube) | 1 | ea |
| | H1 | | H101-9409110 | | 9409110 | BOLT, assembled washer, hex-hd, split lock washer, S, cd- or zn-pltd, 3/8-16UNC-2A x 5/8 | 1 | ea |
| | H2 | | H002-8329624 | | 8329624 | CLIP, S, type, S, phos-ctd, 5/16 in. (vacuum pump to tee tube) | 3 | ea |
| 22-1 | | | | TRI-86521-3 | | COVER, top (windshield wiper motor) | 1 | ea |
| | | | | WO-118553 | | | | |
| 22-1 | | | | TRI-1900 | | SCREW, sp, br or S, No. 6-32NC x 3/32 | 2 | ea |
| | | | | WO-118556 | | | | |
| 22-1 | | | | TRI-1900-1R | | SCREW, sp, br or S, No. 6-32NC x 1/2 | 4 | ea |
| | | | | WO-118555 | | | | |
| 22-1 | | | | TRI-8896-1 | | COVER, valve (windshield wiper motor) | 1 | ea |
| | | | | WO-119999 | | | | |
| 22-1 | | | | TRI-1863-8 | | SCREW, mach, rd-hd, S, No. 4-40NC x 1/4 | 2 | ea |
| | | | | WO-120000 | | | | |
| 22-1 | | 2540-737-2262 | G160-7372262 | TRI-79016-4 | 7372262 | DRIVER, knurled, windshield wiper arm | 2 | ea |
| | | | | WO-A12863 | | | | |
| 22-1 | | | | TRI-F1140 | | GASKET PACKING, "O" ring, class A material (low flexibility) 0.048 thk, 0.250 ID (windshield wiper motor) | 1 | ea |
| | | | | WO-118552 | | | | |
| 22-1 | | | | TRI-8735-2 | | GASKET, top cover (ru) (windshield wiper motor) | 1 | ea |
| | | | | WO-120001 | | | | |
| 22-1 | | | | TRI-8894-3 | | GASKET, valve cover (ru) (windshield wiper motor) | 1 | ea |
| | | | | WO-120109 | | | | |
| | | 5325-700-0997 | G518-7000997 | WO-800802 | 7000997 | GROMMET, ru, split, 1 1/2 ID (windshield wiper tube hole in dash panel) | 1 | ea |
| | | | | WO-808774 | | GROMMET, ru, split, 1/16 ID (windshield wiper tube hole in instrument panel) (used on vehicles after serial No. 74272) | 1 | ea |
| 22-1 | | | | TRI-809-14 | | HANDLE, w/KNOB, assy (windshield wiper motor) | 1 | ea |
| | | | | WO-118568 | | | | |
| 22-1 | | | | TRI-87453 | | PIN, sp, dowel, ribbed, S, 0.105 x 1/2 | 1 | ea |
| | | | | WO-120002 | | | | |
| 22-1 | | | | TRI-86520-1 | | HOUSING, windshield wiper motor | 1 | ea |
| | | | | WO-118550 | | | | |
| 22-1 | | | | TRI-2618-17 | | KICKER, valve (windshield wiper motor) | 1 | ea |
| | | | | WO-120108 | | | | |
| 03-8 | | | G758-8332076 | WO-807845 | 8332076 | LINE, tee to windshield wiper, assy | 1 | ea |
| | | | | | | Composed of: | | |
| | | | | | 142432 | 1 NUT | | |
| | | | | | 44-T-5080- | 1 TUBE (3 3/8 in.) | | |
| | | | | | 15 | | | |

| (1) ILLUSTRATION NO. | (2) REFERENCE SYMBOLS | (3) FEDERAL STOCK NO. | (4) ORDNANCE STOCK NO. | (5) MFR'S PART NO. | (6) ORDNANCE PART NO. | (7) DESCRIPTION | (8) QUANTITY INCORPORATED IN UNIT | (9) UNIT OF ISSUE |
|--|--------------------------|--------------------------|---------------------------|-----------------------|--------------------------|---|--------------------------------------|----------------------|
| GROUP 22—MISCELLANEOUS ACCESSORIES—Continued | | | | | | | | |
| 2202—MIRRORS, REFLECTORS, AND WINDSHIELD WIPERS—Continued | | | | | | | | |
| 03-8 | | | G758-8330238 | WO-807846 | 8330238 | LINE, vacuum pump to tee, assy..... Composed of: | 1 | ea |
| | | | | | 142432 | 2 NUT | | |
| | | | | | 44-T-5080-15 | 1 TUBE (21 $\frac{5}{16}$ in.) | | |
| 18-6 | H17 | 2540-054-7202 | H017-0547202 | | 547202 | MIRROR, rear view, w/ARM, assy..... | 1 | ea |
| | H1 | | H101-0454789 | | 454789 | SCREW, assembled washer, cross-recess-pan-hd, int-teeth lock washer, header-pt, S, cd- or zn-pltd, $\frac{1}{4}$ -20UNC-2A x $\frac{1}{2}$ | 4 | ea |
| | | | | WO-A11860 | | MIRROR, rear view, w/ball pivot STUD, assy..... | 1 | ea |
| | | | | WO-A11862 | | NUT, hex, S, $\frac{1}{4}$ -28NF..... | 1 | ea |
| | | | | WO-A11861 | | WASHER, lock, $\frac{1}{4}$ in..... | 1 | ea |
| | | 2540-737-5189 | G740-7375189 | TRI-63527 | 7375189 | MOTOR, wiper, windshield, assy (superseded by MOTOR 500844) | 1 | ea |
| | | | | WO-681080 | | | | |
| 18-1, 6; 22-1 | H17 | | H017-0500844 | | 500844 | MOTOR, vacuum, windshield wiper, assy (supersedes MOTOR 7375189) | 1 | ea |
| | H1 | | H101-0454788 | | 454788 | SCREW, assembled washer, cross-recess-pan-hd, int-teeth lock washer, header-pt, S, cd- or zn-pltd, No. 10 (0.190)-32NF-2A x $\frac{7}{8}$ | 4 | ea |
| | | | | WO-A11862 | | NUT, hex, S, $\frac{1}{4}$ -28NF (rear view mirror extension arm)..... | 1 | ea |
| 22-1 | | | | TRI-P87350-1J | | PADDLE, w/SHAFT, assy (windshield wiper motor)..... | 1 | ea |
| | | | | WO-120003 | | | | |
| 22-1 | | | | TRI-82812-41 | | PLATE, w/BEARING (windshield wiper motor)..... | 1 | ea |
| | | | | WO-118566 | | | | |
| 22-1 | | | | TRI-1727-28 | | SCREW, mach, flat-hd, br or S, No. 10-32NF-2 x $\frac{7}{8}$ | 2 | ea |
| | | | | WO-118567 | | | | |
| 18-4 | H17 | | H017-0506101 | | 506101 | REFLECTOR, ruby, 4 $\frac{1}{2}$ in dia..... | 4 | ea |
| | H1 | | H101-0191985 | | 191985 | SCREW, int-teeth-lock washer, cross-recess-pan-hd, S, cd- or zn-pltd, $\frac{1}{4}$ -20NC-2 x $\frac{1}{2}$ (used on vehicles through serial No. 55467) | 6 | ea |
| 22-1 | | 5330 532 7338 | G502 5327338 | TRI 2630-3 | 5327338 | RETAINER, valve (windshield wiper motor)..... | 1 | ea |
| | | | | WO-118559 | | | | |
| | | | | WO-118142 | | SCREW, sq-hd, S, cup-pt, $\frac{1}{4}$ -28NF x $\frac{1}{2}$ (rear view mirror extension arm) | 1 | ea |
| | | | | WO-118148 | | SPACER, S, $\frac{25}{64}$ ID, $\frac{5}{8}$ OD, $\frac{1}{16}$ lg (rear view mirror pivot clamp) | 1 | ea |

| | | | | | | | |
|------------|----|---------------|------------------------------|------------------------|---|---|----|
| 22-1 | | | TRI-1895 WO-118570 | | SPACER, windshield wiper motor, plate to housing..... | 2 | ea |
| 22-1 | | 5340-385-4198 | G758-8329997 G502-0389787 | 8329997 A327341 | SPACER, windshield wiper motor to windshield..... | 4 | ea |
| 22-1 | | 2540-709-9460 | G503-7099460 | TRI-2620 WO-118561 | SPRING, windshield wiper motor..... | 1 | ea |
| 22-1 | | | | TRI-79513 WO-673623 | TEE, hose, Y-pattern, 1/4 in. (windshield wiper)..... | 1 | ea |
| 03-8 | H6 | | | 178910 | TEE, flared tube, inverted, 1/4 tube, 1/8 female pipe side (distributor vent tube) | 1 | ea |
| 22-1 | | | | WO-673719 | TUBE, ru, compounded, heavy wall, 1/32 ID, wall thk 3/32, 1 1/4 lg (windshield wiper vacuum line to tee (1), tee to center windshield wiper center tube (1)) (use TUBING 33-T-233) | 2 | ea |
| | | | | WO-677149 | TUBE, ru, compounded, heavy wall, 1/32 ID, wall thick- ness 3/32, 6 1/2 lg (shut-off valve to vacuum tube) (use TUBING 33-T-233) | 1 | ea |
| 22-1 | | | | WO-674651 | TUBE, ru, compounded, heavy wall, 1/32 ID, wall thk 3/32, 8 lg (tee to left windshield wiper) (use TUBING 33-T-233) | 1 | ea |
| | | | | WO-677150 | TUBE, ru, compounded, heavy wall, 1/32 ID, wall thk 3/32, 9 1/2 lg (windshield wiper center tube to right wiper) (use TUBING 33-T-233) | 1 | ea |
| | | | | WO-680768 | TUBE, ru, compounded, heavy wall, 1/32 ID, wall thk 3/32, 55 lg (windshield wiper, under hood to shutoff valve) (use TUBING 33-T-233) | 1 | ea |
| 22-1 | | | | WO-677153 | TUBE, S, seamless, pltd, 1/4 OD, 0.030 thk of wall, dev-lg 25 31/32 (windshield wiper, center) (use TUBING 44-T- 5080-15) | 1 | ea |
| 22-1 | | | | WO-681026 | TUBE, S, seamless, pltd, 1/4 OD, 0.030 thk of wall, dev-lg 22 1/2 (upper corner, windshield wiper) (use TUBING 44-T-5080-15) | 1 | ea |
| | H4 | | H004-0121600 | 120871 | CLAMP, open, cable, conduit or pipe, S or MI, cd- or zn-pltd, 1/8 pipe size, hole for 3/16 bolt | 1 | ea |
| | H1 | | H101-0454783 | 454783 | SCREW, assembled washer, cross-recess, pan-hd, int- teeth lock washer, header-pt, S, cd- or zn-pltd, No. 10 (0.190)-24NC-2A x 1/2 | 1 | ea |
| | H7 | | H007-0218065 | 44-T-5080- 15 | TUBING, cop, seamless, soft annealed, size 1/4, 0.250 OD, 0.035 thk of wall | † | ft |
| | H7 | | H007-0878000 | 33-T-233 | TUBING, ru, compounded, heavy wall, 1/32 ID, 3/32 wall thk | † | ft |
| 18-6; 22-1 | | | G758-8329996 | 8329996 | VALVE, shutoff, windshield wiper..... | 1 | ea |
| | H1 | | H101-0454783 | 454783 | SCREW, assembled washer, cross-recess, pan-hd, int- teeth lock washer, header-pt, S, cd- or zn-pltd, No. 10 (0.190)-24NC-2A x 1/2 | 2 | ea |

| (1) ILLUSTRATION NO. | (2) REFER- ENCE SYMBOLS | (3) FEDERAL STOCK NO. | (4) ORDNANCE STOCK NO. | (5) MFR'S PART NO. | (6) ORDNANCE PART NO. | (7) DESCRIPTION | (8) QUANTITY INCOR- PORATED IN UNIT | (9) UNIT OF ISSUE |
|-------------------------|----------------------------------|-----------------------------|------------------------------|---|-----------------------------|--|---|----------------------------|
| | | | | | | GROUP 22—MISCELLANEOUS ACCESSORIES—Continued | | |
| | | | | | | 2202—MIRRORS, REFLECTORS, AND WINDSHIELD WIPERS—Continued | | |
| 22-1 | | | | TRI-2631-1 WO-118558 | | VALVE, slide valve (windshield wiper motor)..... | 1 | ea |
| 22-1 | | 5330-885-4165 | G502-0180653 | TRI-8741-3 WO-118557 | A327342 | WASHER, felt, 0.189 ID, $\frac{3}{8}$ OD, $\frac{1}{32}$ thk (windshield wiper motor) | 1 | ea |
| 22-1 | | 2520-885-4216 | G502-0482430 | TRI-2617 WO-118560 | A327340 | YOKE, valve kicker (windshield wiper motor)..... | 1 | ea |
| | | | | | | 2208.1—SPEEDOMETER | | |
| | | 6680-740-9702 | G744-7409702 | AC-1581449 SW-G418041 WO-805130 | 7409702 | CASING, shaft, assy..... | 1 | ea |
| | | 6680-832-7565 | G744-7355830 | AC-1581351 SW-G418049 WO-119212 | 7355830 | CORE, shaft, assy..... | 1 | ea |
| | | 5330-753-9689 | G742-7539689 | AC-1568362 SW-418046 WO-118444 | 7539689 | GASKET, ru, flex shaft, $1\frac{13}{32}$ ID, $\frac{1}{4}$ OD, $\frac{1}{16}$ thk..... | 1 | ea |
| | | 5330-753-9688 | G742-7539688 | AC-1568220 SW-418045 WO-118443 | 7539688 | GASKET, ru, $\frac{1}{4}$ ID, $\frac{57}{64}$ OD, $\frac{9}{64}$ thk..... | 1 | ea |
| 08-2; 12-3 | | | G758-8328480 | SP-18-453-10 WO-806718 | 8328480 | GEAR, driven, w/integral SHAFT (15T)..... | 1 | ea |
| | | 5325-734-6945 | G740-7346945 | WO-801809 | 7346945 | GROMMET, split, ru, $\frac{3}{4}$ ID (shaft in dash)..... | 1 | ea |
| | | 6680-832-7566 | G744-7389881 | AC-1581436 SW-446125 WO-805129 | 7389881 | SHAFT, flexible, assy (includes CASING and CORE)..... | 1 | ea |
| | H4 | | H004-0327736 | | 120527 | CLIP, closed, S, $\frac{5}{8}$, No. 10 screw hole (speedometer shaft to frame side member) | 1 | ea |
| | H1 | 5310-012-0361 | H001-4135661 | | 120361 | NUT, mach screw, hex, S, cd- or zn-pltd, No. 10 (0.190)-24NC-2 | 1 | ea |
| | H1 | | H101-0454782 | | 454782 | SCREW, assembled washer, cross-recess-pan-pd, int- teeth lock washer, header-pt, S, cd- or zn-pltd, No. 10 (0.190)-24NC-2A x $\frac{5}{8}$ | 1 | ea |
| 08-2; 12-3 | | | G758-8328481 | SP-55-454-3 SP-18-454-3 WO-806719 | 8328481 | SLEEVE, driven gear..... | 1 | ea |

| | | | | | | | | | | | | |
|----------------------|----|---------------|--------------|---|---|---|---------------|--------------|---------|--|---|----|
| 06-9, 10; 18-6, 7 | H1 | 5310-043-1680 | G742-7760396 | AC-1580260 SW-503A WO-118101 | 7760396 | SPEEDOMETER, waterproof, assy (used w/CLUSTER 7418835 listed in subgroup 0607 (luminous dial) (superseded by SPEEDOMETER 8376375) (M38A1) | 1 | ea | | | | |
| | | | G742-8376375 | WO-808913 SW-503C AC-1582373 AL-EO-12205 WO-809819 AL-2235 | 8376375 | SPEEDOMETER, waterproof (non-luminous), assy (supersedes SPEEDOMETER 7760396) (used w/CLUSTER 8376619, 7954878 and 7954879 listed in subgroup 0607) | 1 | ea | | | | |
| 373 | H1 | 5310-043-1680 | H101-0431680 | WO-801790 WO-807466 WO-801820 WO-800537 WO-806857 WO-811286 WO-909342 WO-802634 WO-800766 | 431680 | NUT, plain, hex, S, cd- or zn-pltd, No. 10-32NC | 2 | ea | | | | |
| | | | | | | WASHER, lock, S, cd- or zn-fin, No. 10 | 2 | ea | | | | |
| | | | | | 2210-VEHICULAR DATA PLATES | | | | | | | |
| | | | | | | | | | 8677069 | DECAL, battery box cover warning right front fender and splash apron) (M170) | 1 | ea |
| | | | | | 18-6 | | 2540-769-7562 | G740-7697562 | 7697562 | DECAL, bell housing drain plug locating | 1 | ea |
| | | | | | 18-6 | | 2540-769-7554 | G740-7697554 | 7697554 | PLATE, caution, vehicle road speed | 1 | ea |
| | | | | | 18-6 | | | | 8677436 | PLATE, fording ventilator valve | 1 | ea |
| | | | | | 18-7 | | | G758-8333426 | 8333426 | PLATE, general information, assy | 1 | ea |
| | | | | | | | 2540-741-2583 | G740-7412583 | 7412583 | PLATE, identification (army) (M170) | 1 | ea |
| | | | | | | | 2540-796-7555 | G740-7697555 | 7697555 | PLATE, identification (w/o WINCH) (M170) | 1 | ea |
| | | | | | | | | | | PLATE, mounting vehicular data | 1 | ea |
| | | | | | 18-6, 7 | | 2540-769-7561 | G740-7697561 | 7697561 | PLATE, name, patent and serial number right wheel-house panel) | 1 | ea |
| | | | | | 18-6 | | | G758-8673359 | 8673359 | PLATE, responsible agency | 1 | ea |
| | | | | | 18-7 | | | G758-8333427 | 8333427 | PLATE, servicing data (M38A1) | 1 | ea |
| | | | | | 18-6 | | | G758-8386440 | 8386440 | PLATE, servicing data (M170) | 1 | ea |
| | | | | | 18-7 | | | G758-8333429 | 8333429 | PLATE, shifting instructions and publication data | 1 | ea |
| | | | | | | | | | | PLATE, shifting instruction and publication date (marine corps) | 1 | ea |
| | | | | | 18-6 | | | G758-8386439 | 8386439 | PLATE, weight and dimension data (M38A1) | 1 | ea |
| | | | | | 18-7 | | | G758-8333428 | 8333428 | PLATE, weight and dimension data (M170) | 1 | ea |
| | | | | | | H1 | 5320-010-9953 | H001-0932002 | 109953 | RIVET, tubular, oval-hd, br, 1/8 x 1/8 (data plates to mounting plate) | ‡ | ea |
| | H1 | 5305-016-1790 | H101-0161790 | 161790 | SCREW, THREADED, tapping, cross-recess, pan-hd, gimlet-pt, sh-met-thd, S, cd- or zn-pltd, No. 6 (0.138) x 3/8 (mounting plates) | ‡ | ea | | | | | |

ALPHABETICAL INDEX

This index does not include standardized hardware, attaching, or associated parts which are indented under the primary item and which are not otherwise listed in their own alphabetical order in the supply manual. Such parts are readily found by referring to the item which requires their use. To find the attaching parts for the starter switch, for example, locate the "SWITCH, starter" in this index and refer to referenced subgroup (0603), where the indented attaching parts for the switch (SCREW and WASHER), will be found.

| ITEM | SUBGROUP | ITEM | SUBGROUP |
|---|----------|---|----------|
| ABSORBER, shock | 1604.1 | BANDS | |
| ACID, storage battery | 0612 | Clamp, air cleaner | 0304.1 |
| ADAPTERS | | Worm, winch brake | 2001.1 |
| Air vent, fuel pump | 0302.1 | BARS | |
| Horn switch | 0611 | Bumper | 2101 |
| Power-take-off | 2002.1 | Stabilizer | 1605 |
| Transmission main shaft bearing..... | 0702.3 | Tie, brake master cylinder..... | 1204.1 |
| AMMETER, instrument panel | 0607 | Tie, universal joint | 0900 |
| ANTI-RATTLE, hand brake pawl rod..... | 1201 | BASES | |
| ANTI-SQUEAK | | Distributor | 0604.1 |
| Fender to body side panel..... | 1701 | Generator regulator | 0602 |
| Fuel tank | 0306 | Starter | 0603 |
| APRON, splash, fender..... | 1701 | BATTERY | 0612 |
| ARMATURES | | BEARINGS | |
| Generator | {0601.1 | Ball, | |
| | }0601.3 | Commutator end | 0601.1 |
| Generator regulator | 0602 | Drive end, generator | 0601.1 |
| Starter | 0603 | Power-take-off | 2002.1 |
| ARMS | | Transfer case (output clutch shaft)..... | 0802.5 |
| Distributor | 0604.1 | Transmission main drive gear | 0702.1 |
| Generator brush | 0601.1 | Winch | 2001.3 |
| Pitman steering gear | 1401 | Winch worm shaft | 2001.1 |
| Rear view mirror | 2202 | Brake pedal shaft bracket | 1206 |
| Rocker, engine | 0105.2 | Bushing type, | |
| Rocker, fuel pump | 0302.1 | Front and rear spring bracket..... | 1501 |
| Spreader, litter rack | 1812 | Front spring shackle | 1601.1 |
| Windshield wiper | 2202 | Pilot, output clutch gear shaft..... | 0802.7 |
| AXLES | | Rocker arm pin | 0302.1 |
| Carburetor float lever | 0301 | Speedometer drive gear | 0802.7 |
| Front | 1000 | Steering gear | 1401 |
| Rear | 1100 | Steering knuckle, front axle..... | 1004 |
| BACKS, driver's and passenger seat..... | 1806 | Pilot transfer output clutch gear shaft | 0802.7 |
| BAFFLE, transmission input shaft oil..... | 0702.1 | Camshaft | 0105.3 |
| BALLS | | Clutch winch housing | 2001.1 |
| Check, carburetor | 0301 | Connecting rod | 0104.2 |
| Detent, shifter shaft | 0804 | Drum, winch shaft | 2001.1 |
| Fulcrum, transmission gear shift lever..... | 0704 | Engine oil pump | 0106.1 |
| Poppet, gear shifter shaft..... | 0704 | Generator | {0601.1 |
| Steering control | 1401 | | }0601.3 |
| Universal joint | 1006 | Main, engine crankshaft | 0102.2 |
| | | Pilot, engine clutch | 0201 |
| | | Pin, fuel pump rocker arm | 0302.1 |
| | | Rear spring | 1601.3 |
| | | Release, clutch | 0202 |
| | | Roller, journal, transfer countershaft | 0802.3 |
| | | Starter | 0603 |
| | | Steering control | 1401.1 |
| | | Transmission idler gear | 0702.5 |

ALPHABETICAL INDEX—Continued

| ITEM | SUBGROUP | ITEM | SUBGROUP |
|--|-------------|--|-------------|
| BEARINGS—Continued | | BOLTS—Continued | |
| Universal joint | 0900 | Oil filter support bracket | 0106.2 |
| Water pump | 0504 | Rear axle bumper | 1601.3 |
| Winch worm gear housing | 2001.1 | Rear spring | 1601.3 |
| BELLCRANK, steering gear | 1401 | Set, power-take-off | 2002.1 |
| BELT, drive, fan and generator | 0505 | Transfer case support | 0800 |
| BLADES | | BOOTS | |
| Engine | 0505 | Brake master cylinder | 1204.1 |
| Starter switch | 0603 | Brake wheel cylinder | 1204.3 |
| Windshield wiper | 2202 | Gear shift lever | 1805 |
| BLOCKS | | Power-take-off shift lever | 2002.5 |
| Adjusting, accelerator throttle rod | 0312 | BOSS, tool box weld flanged | 1808 |
| Brush and commutator, flood light extension cable shaft | 0609.2 | BOW, top | 2201 |
| Cylinder | 0101 | BOX, glove, side and bottom | 1808 |
| Differential drive shaft | 1102 | BRACES | |
| BOARDS, stabilizer | 2201 | Adjusting, generator belt tension | {0601.1 |
| BODIES | | | }0601.3 |
| Air cleaner | 0304.1 | Fender | 1701 |
| Blackout head light | 0609.1 | Hanger winch bearing | 2001.3 |
| Carburetor | 0301 | Seat back frame | 1806 |
| Carburetor choke valve | 0301 | BRACKETS | |
| Carburetor throttle valve | 0301 | Accelerator bellcrank | 0312 |
| Engine oil pump | 0106.1 | Battery box support | 0612 |
| Fuel pump section | 0302.1 | Battery catch clamp | 0612 |
| Fuel pump vacuum section | 0302.1 | Body | |
| Hand brake | 1201 | Hold-down | 1805 |
| Head light beam indicator light | 0607 | Hold-down outer and tail light | 1804 |
| Instrument cluster light | 0607 | Tie-down | 1501 |
| Metering valve, vent, crankcase | 0304.5 | Brake | |
| Oil filter | 0106.2 | Line | 1204.5 |
| Spare gas can bracket | 1808 | Line tee | 1204.5 |
| Tail light | 0609.1 | Pedal | 1206 |
| Truck | 1800 | Pedal spring | 1501 |
| Water pump | 0504 | Carburetor choke tube | 0301 |
| BOLTS | | Catch, hood to windshield | 1804 |
| Adjusting, generator brace to front engine plate | {0601.1 | Circuit closure, auxiliary light | 0609.2 |
| | }0601.3 | Circuit closure, ignition switch | 0607 |
| Battery terminal | 0612 | Clutch pressure plate | 0201 |
| Body mounting | 1801 | Connector, circuit closure cap | 0609.2 |
| Brake master cylinder | 1204.1 | Crankcase oil line clip | 0106.6 |
| Connecting rod cap | 0104.2 | Distributor | 0604.1 |
| Cylinder head | 0101 | Door hinge | 1804 |
| Fender brace | 1701 | End, generator | 0601.1 |
| Front axle bumper | 1601.1 | Engine | |
| Front axle steering knuckle | 1004 | Clutch control tube stud | 0202 |
| Front brake backing plate | 1202 | Lifting | 0100.1 |
| Front spring | 1601.1 | Oil filter | 0106.2 |
| Generator | {0601.1 | Support | 1501 |
| | }0601.3 | Front and rear spring pivot | 1501 |
| Hand brake drum | 1201 | Front and rear spring shackle | 1501 |
| Hood catch | 1703 | Front brake hose | 1501 |
| Hood catch "U" | 1703 | Fuel line clip | 1501 |
| Locking, piston pin | 0104.1 | Gas tank support | 1805 |
| | | Generator regulator | 0602 |
| | | Ground cable | 1501 |

ALPHABETICAL INDEX—Continued

| ITEM | SUBGROUP | ITEM | SUBGROUP |
|---|----------|---|----------|
| BRACKETS—Continued | | BRUSHES | |
| Ground connector | 0613.1 | Auxiliary lights | 0609.2 |
| Guide, tool box lid catch | 1808 | Generator | {0601.1 |
| Hand brake | 1201 | Starter | {0601.3 |
| Hanger, battery box | 0612 | | 0603 |
| Hinge, litter rack | 1812 | BUCKLES | |
| Hold-down, body | 1804 | Spare gas can strap | 1808 |
| Hood catch | 1703 | Strap | 1808 |
| Hood hinge | 1804 | Tongueless, | |
| Horn | 0611 | Curtain stowage | 2201 |
| Instrument panel | 0607 | Top hold-down strap | 2201 |
| Litter stowage | 1804 | Windshield hold-down strap | 1804 |
| Locking and pivot, seat frame..... | 1806 | BUMPERETTE, rear | |
| Mounting, | | | 2001 |
| Auxiliary light | 0609.2 | BUMPERS | |
| Engine | 0100.2 | Axle | {1601.1 |
| Exhaust pipe extension | 0401 | | {1601.3 |
| Machine gun | 1501 | Windshield to hood | 1804 |
| Rear view mirror | 2202 | BUSHINGS | |
| Speedometer | 0607 | Blackout marker light connector cable..... | 0609.1 |
| Muffler support clamp | 0401 | Connector, wiring harness | 0613.1 |
| Pintle lifting | 1503 | Distributor base | 0604.1 |
| Polarizing, electrical connector | 0617 | Drum, winch shaft | 2001.1 |
| Power-take-off winch latch | 2002.5 | Gear housing winch cover | 2001.1 |
| Radiator guard support | 1501 | Generator brush plate | 0601.3 |
| Rear seat pivot | 1804 | Harness, generator (in dash, split type)..... | 0613.1 |
| Receptacle cover | 0613.1 | Horn switch | 0611 |
| Retainer and pivot, lifter rack..... | 1812 | Insulating, generator regulator | 0602 |
| Rocker arm shaft | 0105.2 | Insulating, starter | 0603 |
| Seat retaining | 1806 | Shock absorber | 1604.1 |
| Shock absorber | 1501 | Stabilizer link | 1605 |
| Shovel stowage | 1808 | Steering column jacket | 1401 |
| Spare gasoline can | 1808 | Terminal | |
| Spare wheel | 1504 | Head lamp beam indicator light | 0607 |
| Stabilizer mounting bar | 1605 | Instrument cluster harness | 0607 |
| Stay cable, engine | 0100.2 | Instrument light | 0607 |
| Steering bellcrank support | 1501 | Trailer coupling | 0617 |
| Stowage, top bow, front..... | 1808 | Worm gear, winch housing | 2001.1 |
| Stowage, top bow, rear | 1808 | CABLES | |
| Support, | | Automotive, low tension | {0612 |
| Crankcase ventilator oil filler pipe..... | 0106.5 | | {0613.1 |
| Hood | 1703 | Auxiliary lights | 0609.2 |
| Side rail, top to windshield..... | 1804 | Battery | 0612 |
| Stabilizer board | 1804 | Clutch control lever | 0202 |
| Winch frame | 2001.1 | Distributor breaker lever to coil | 0604.1 |
| Tail light and trailer connection to | | Extension, blackout driving light | 0609.1 |
| body side panel | 1804 | Fuel gage | 0613.1 |
| Tie rod, air deflector and radiator guard..... | 0502 | Generator connecting | 0601.3 |
| Vent dual control support | 0304.5 | Hand brake control | 1201 |
| Windshield to hood bumper | 1804 | Head light | 0609.1 |
| BRAKES | | Horn switch | 0611 |
| Hand | 1201 | Receptacle | 0617 |
| Service | 1202 | Spark plug | 0605 |
| BREAKER, circuit, generator regulator..... | | Stay, engine | 0100.2 |
| | 0602 | Winch, w/hook | 2001.1 |

ALPHABETICAL INDEX—Continued

| ITEM | SUBGROUP | ITEM | SUBGROUP |
|--|----------|--|----------|
| CAGE, front axle universal joint | 1006 | CHECK, carburetor fuel intake | 0301 |
| CAM, distributor | 0604.1 | CHOKER, generator regulator | 0602 |
| CAMSHAFT | 0105.3 | CLAMPS | |
| CAPACITORS | | Air cleaner | 0304.1 |
| Distributor | 0604.1 | Cable to dash | 0612 |
| Generator armature circuit | 0601.3 | Carburetor choke control conduit | 0301 |
| Generator regulator | 0602 | Clip, brake line | 1204.5 |
| CAPS | | Engine oil filter body | 0106.2 |
| Air cleaner | 0304.1 | Hand brake conduit | 1201 |
| Bearing, front axle differential | 1002 | Hose | |
| Bearing, rear axle differential | 1102 | Air cleaner | 0304.1 |
| Closed end winch bearing | 2001.1 | Clutch release mechanism | 0202 |
| Crankshaft main bearing | 0102.2 | Cylinder head | 0503 |
| Distributor | 0604.1 | Gear shift lever boot | 1805 |
| Dust, universal joint sleeve yoke | 0900 | Radiator | 0503 |
| Filler, brake master cylinder | 1204.1 | Mounting, gages | 0607 |
| Fuel pump diaphragm return spring | 0302.1 | Mounting, steering gear | 1401 |
| Fuel tank filler | 0306 | Pivot, rear mirror | 2202 |
| Hanger, winch bearing | 2001.3 | Precleaner to air cleaner | 0304.5 |
| Horn button | 0611 | Rear view mirror arm extension | 2202 |
| Hub | 1311 | Steering | |
| Radiator | 0501 | Column | 1401 |
| Rotation, exhaust valve | 0105.1 | Gear jacket support | 1401 |
| Spark plug cable | 0605 | Tie rod end | 1401 |
| Steering knuckle | 1004 | CLASP, battery catch clamp release | 0612 |
| Transfer case rear output shaft | 0802.7 | CLEANER, air | 0304.1 |
| Transfer output shaft front bearing | 0802.5 | CLIPS | |
| Transmission gear shift lever housing | 0704 | Battery cable | 0612 |
| Valve, tire | 1313 | Brake | |
| Worm shaft winch bearing | 2001.1 | Line | 1204.5 |
| CARBURETOR | 0301 | Tube | 1204.5 |
| CARRIER, engine clutch release bearing | 0202 | Tubing | 1204.5 |
| CASES | | Chassis wiring | 0613.1 |
| Differential | {1002 | Clutch pressure spring | 0202 |
| | 1102 | Distributor | 0604.1 |
| Generator regulator | 0602 | Fuel line | 0306 |
| Hanger, winch bearing | 2001.3 | Fuel pump primer lever | 0302.1 |
| Transfer | 0801 | Fuel tank | 0306 |
| Transmission | 0701 | Generator | 0601.3 |
| CASING, speedometer shaft | 2208.1 | Instrument panel | 0607 |
| CATCHES | | Oil line to cylinder head | 0106.6 |
| Hood | 1703 | Pintle, snap lifting | 1503 |
| Hood to windshield | 1804 | Radiator to guard | 1501 |
| Tool box lid | 1808 | Retaining, hanging support | 1812 |
| Windshield clamp | 1804 | Seat cushion spring | 1806 |
| CHAINS | | Spring leaf | {1601.1 |
| Frame snap clip | 1503 | | 1601.3 |
| Fuel tank cap | 0306 | Spring, spreader arm | 1812 |
| Roller, power-take-off | 2002.1 | Vacuum pump (to tee tube) | 2202 |
| Seat hinge pivot | 1806 | Valve spring cover | 0105.1 |
| Top rail w/ring and retaining pin | 2201 | Vent system, underwater (closed) | 0304.5 |
| Top side rail | 1812 | Windshield wiper hose | 2202 |
| | | CLUSTER, instrument | 0607 |

ALPHABETICAL INDEX—Continued

| ITEM | SUBGROUP | ITEM | SUBGROUP |
|--|---------------|--|---------------|
| CLUTCHES | | CORES | |
| Starter | 0603 | Speedometer flexible shaft | 2208.1 |
| Winch | 2001.1 | Valve, tire | 1313 |
| COCKS | | COUNTERSHAFTS | |
| Drain | 0101 | Transfer | 0802.2 |
| Drain, radiator | 0501 | Transmission | 0702.5 |
| Fuel shut-off | 0306 | COUPLING, transfer case air vent line | 0304.5 |
| COILS | | COVERS | |
| Distributor | 0604.1 | Axle housing | 1001 |
| Ignition | 0605 | Brake master cylinder | 1204.1 |
| COIL SET, generator | 0601.3 | Clutch pressure plate | 0201 |
| COLLARS | | Clutch winch housing | 2001.1 |
| Distributor | 0604.1 | Crash pad, driver's seat frame | 1806 |
| Generator spacing | 0601.3 | Distributor and coil | 0604.1 |
| COLLECTOR, oil, transmission countershaft | | Engine oil filter | 0106.2 |
| gear | 0702.5 | Engine oil pump body | 0106.1 |
| CONDUITS | | Floor pan | 1805 |
| Choke control | 0312 | Floor pan drain hole | 1805 |
| Spark plug cable | 0605 | Flywheel housing | 0103 |
| Throttle control | 0312 | Fuel pump pulsator diaphragm | 0302.1 |
| Underwater vent system | 0304.5 | Fuel pump vacuum section | 0302.1 |
| CONES | | Generator regulator | 0602 |
| King pin bearing | 1004 | Grease retaining, steering tie rod end | 1401 |
| Tapered | | Hood | 1703 |
| Axle differential | 1102 | Housing, power-take-off | 2002.1 |
| Front axle differential | 1002 | Inspection, floor, master brake cylinder | 1805 |
| Hub roller bearing | 1311 | Instrument panel and high beam light | 0607 |
| Transfer case (output shaft bearing) | 0802.7 | Main drive gear bearing | 0701 |
| CONNECTORS | | Plate, trailer receptacle | 1812 |
| Auxiliary lights | 0609.2 | Rear axle housing | 1101 |
| Ball check (underwater vent system) | 0304.5 | Receptacle | 0613.1 |
| Cable | | Rocker arm | 0105.2 |
| Blackout marker light | 0609.1 | Shift lever grease retainer | 2002.5 |
| Horn switch | 0611 | Steering gear housing | 1401 |
| Trailer coupling | 0617 | Terminal, auxiliary lights | 0609.2 |
| Wiring harness | 0613.1 | Timing gear | 0105.5 |
| Flared tube distributor | 0604.1 | Top | 2201 |
| Flared tube inverted, sending unit | 0610 | Trailer coupling receptacle | 0617 |
| Generator regulator | 0602 | Transfer case bottom | 0801 |
| Head light beam indicator light | 0607 | Transmission gear shift lever | 0704 |
| Instrument cluster harness | 0607 | Transmission main drive gear bearing | 0704 |
| Oil line | 0106.6 | Valve spring | 0105.1 |
| Spark plug cable | 0605 | Windshield wiper motor top | 2202 |
| Starter | 0603 | Windshield wiper motor valve | 2202 |
| Terminal, wiring harness | 0613.1 | Worm gear housing | 2001.1 |
| Vent tube to manifold tee | 0106.5 | CRANKSHAFT | 0102.1 |
| CONTACT | | CROSSMEMBER | |
| Blackout tail and stop light cable | 0609.1 | Frame | 1501 |
| Generator regulator circuit breaker | 0602 | Rear engine support | 1501 |
| CONTROLS | | CUPS | |
| Choke | 0312 | Air cleaner | 0304.1 |
| Dual vent system | 0304.5 | Ball, steering gear | 1401 |
| Throttle | 0312 | Brake master cylinder | 1204.1 |
| | | Brake wheel cylinder | 1204.3 |
| | | Clutch pressure spring | 0202 |

ALPHABETICAL INDEX—Continued

| ITEM | SUBGROUP | ITEM | SUBGROUP |
|--|----------|--|----------|
| CUPS—Continued | | DRUMS | |
| Differential, rear axle | 1102 | Brake | 1311 |
| Front axle differential | 1002 | Hand brake | 1201 |
| Fuel tank | 1504 | Winch | 2001.1 |
| King pin bearing | 1004 | Winch worm brake | 2001.1 |
| Retainer, brake shoe hold-down spring | 1202 | ECCENTRIC, adjusting, brake shoe | |
| Retainer, glove box door lock | 1808 | 1202 | |
| Retaining, transfer case support insulator | {0800 | ELBOWS | |
| | {1501 | Carburetor vent | 0306 |
| Tapered, transfer output shaft bearing | 0802.7 | Distributor, vent tube to tee | 0304.5 |
| Tapered wheel hub bearing | 1311 | Flared, tube | {0306 |
| CURTAINS | | | {1105.5 |
| Door and side | 2201 | Fuel section | 0306 |
| Rear | 2201 | Generator box | 0601.1 |
| CUSHIONS | | Generator terminal receptacle | 0601.3 |
| Body mounting | 1801 | Oil line to cylinder block | 0106.6 |
| Engine support | 0100.2 | Pipe, engine oil pressure unit | 0610 |
| Generator regulator mounting bracket | 0602 | Pipe, fuel system | 0306 |
| Seat | 1806 | Rear axle vent plug | 1105.5 |
| Wheelhouse | 1812 | Rocker arm cover | 0105.2 |
| CYLINDERS | | Vacuum section | 0306 |
| Brake master | 1204.1 | Vent body to nipple | 0106.5 |
| Brake wheel | 1204.3 | Vent line | 0304.5 |
| DECALS | | Vent valve to vacuum tube tee | 0304.5 |
| Locating, bell housing drain plug | 2210 | ELEMENTS | |
| Warning, battery box cover | 2210 | Air cleaner | 0304.1 |
| DEFLECTOR, air, radiator | | Engine oil filter | 0106.2 |
| 0502 | | Fuel filter | 0309 |
| DIAPHRAGMS | | END, steering tie rods | |
| Carburetor metering rod | 0301 | 1401 | |
| Carburetor pump | 0301 | ENGINE | |
| Fuel pump | | 0100.2 | |
| Fuel section | 0302.1 | EXPANDER, piston ring | |
| Pulsator | 0302.1 | 0104.1 | |
| Vacuum section | 0302.1 | EXTENSIONS | |
| DIFFERENTIALS | | Body outrigger | 1501 |
| Front axle | 1002 | Exhaust pipe | 0401 |
| Rear axle | 1102 | Frame cross member | 1501 |
| DISK | | Reel light | 0609.2 |
| Horn switch | 0611 | Top deck header | 2201 |
| Pressure plate | 0201 | EYELET, top bow | |
| DISTRIBUTOR | | 2201 | |
| 0604.1 | | FACING, clutch | |
| DOORS | | 0201 | |
| Blackout | | FAN, engine | |
| Head light | 0609.1 | 0505 | |
| Marker light | 0609.1 | FASTENERS | |
| Tail and stop light | 0609.1 | Curtain | 2201 |
| Tail lamp | 0609.1 | Head light cable | 0609.1 |
| Body | 2201 | Instrument panel | 0607 |
| Glove box | 1808 | Oil line to cylinder head | 0106.6 |
| Service head light | 0609.1 | Wiring harness | 0613.1 |
| DRIVER, windshield wiper arm | | FENDER | |
| 2202 | | 1701 | |
| | | FERRULE, spark plug cable..... | |
| | | 0605 | |
| | | FILLERS | |
| | | Fender brace | 1701 |
| | | Windshield center bar | 1804 |
| | | Windshield glass weatherstrip | 1804 |

ALPHABETICAL INDEX—Continued

| ITEM | SUBGROUP | ITEM | SUBGROUP |
|---|----------|---|----------|
| FILTERS | | GAGES | |
| Blackout tail light door | 0609.1 | Fuel | 0607 |
| Blackout tail light lens | 0609.1 | Oil lever, engine | 0106.6 |
| Engine oil | 0106.2 | Oil pressure | 0607 |
| Fuel | 0309 | Water temperature | 0607 |
| Generator regulator | 0602 | | |
| FITTINGS | | GASKETS | |
| Brake master cylinder | 1204.1 | Air cleaner | 0304.1 |
| Drag link | 1401 | Air cleaner cap | 0304.1 |
| Engine oil timing gear | 0106.6 | Air cleaner element to upper body | 0304.1 |
| Grease, winch hanger bearing | 2001.3 | Axle housing cover | 1101 |
| Lubricating | | Axle shaft grease retainer | 1311 |
| | {1401 | Bell housing to rear engine plate | 0103 |
| Ball check valve | {1601.1 | Blackout | |
| | {1601.3 | Marker light door | 0609.1 |
| Propeller shaft and universal joints | | Tail light door filter | 0609.1 |
| hydraulic type | 0900 | Tail light door lens | 0609.1 |
| Rear axle housing | 1105.5 | Brake line tee | 1204.5 |
| Rear wheel bearing | 1104.1 | Brake master cylinder | 1204.1 |
| Steering drag link bellcrank | | Carburetor | |
| hydraulic type | 1401 | Body throttle valve | 0301 |
| Steering tie rods hydraulic type | 1401 | Choke valve body to float body | 0301 |
| Vertical roller guide pin | 2001.1 | Float needle valve seat | 0301 |
| Transfer case (shift lever pivot pin) | 0804 | Fuel inlet strainer nut | 0301 |
| | | Pump passage plug | 0301 |
| | | Cover, axle housing | 1001 |
| FLANGES | | Crankcase ventilator to valve spring cover .. | 0106.5 |
| Companion, transfer case output shaft | 0802.7 | Cylinder block to rear engine plate | 0103 |
| Drive, front axle shaft | 1006 | Cylinder head | 0101 |
| Steering knuckle | 1004 | Differential bevel pinion oil seal | {1002 |
| | | | {1102 |
| | | Distributor | 0604.1 |
| FLAPS | | Engine | |
| Canvas, deck side | 2201 | Exhaust manifold | 0108 |
| Canvas top | 2201 | Oil filter cover | 0106.2 |
| FLOAT, carburetor | 0301 | Oil filter cover bolt | 0106.2 |
| | | Oil filter head | 0106.2 |
| FLYWHEEL | 0103 | Oil pan | 0106.6 |
| | | Oil pan drain plug | 0106.6 |
| FORKS | | Oil pump | 0106.1 |
| Clutch release | 0202 | Oil pump body cover | 0106.1 |
| Shifter, transfer case output clutch gear | 0804 | Oil pump spring retainer | 0106.1 |
| Shifter, transfer case output shaft | | Oil strainer support | 0106.6 |
| sliding gear | 0804 | Rear end plate | 0103 |
| Transmission first speed and reverse | | Exhaust pipe flange | 0401 |
| gear shifter | 0704 | Exhaust pipe to extension and | |
| Transmission second and third speed | | extension to muffler flange | 0401 |
| gear shifter | 0704 | Flange, drive, axle shaft | 1006 |
| | | Floor drain hole cover | 1805 |
| FRAMES | | Flywheel housing clutch linkage | |
| Battery hold-down | 0612 | inspection cover | 0103 |
| Chassis | 1501 | Fuel | |
| Generator | {0601.1 | Filter cover plate | 0309 |
| | {0601.3 | Level sending unit | 0610 |
| Seat | 1806 | Pump fuel section valve | 0302.1 |
| Starter | 0603 | Pump oil priming lever pin | 0302.1 |
| Winch | 2001.1 | Pump to cylinder block | 0302.1 |
| Windshield | 1804 | Pump vacuum section cover | 0302.1 |
| FULCRUM, clutch release lever | 0202 | | |

ALPHABETICAL INDEX—Continued

| ITEM | SUBGROUP | ITEM | SUBGROUP |
|---|----------|--|----------|
| GASKETS—Continued | | GEARS—Continued | |
| Fuel—Continued | | Ring, flywheel | 0103 |
| Pump vacuum section cover screw | 0302.1 | Sliding, power-take-off | 2002.1 |
| Pump vacuum section valve | 0302.1 | Sliding, transfer case output shaft | 0802.7 |
| Tank air vent | 0309 | Speedometer driven | 2208.1 |
| Tank cap | 0306 | Steering | 1401 |
| Generator | {0601.1 | Transfer case output shaft | 0802.7 |
| | 0601.3 | Transfer countershaft | 0802.3 |
| Generator regulator | 0602 | Transmission countershaft | 0702.5 |
| Housing, gear, power-take-off | 2002.1 | Transmission main shaft | 0702.3 |
| Instrument and high beam indicator lights.... | 0607 | Transmission reverse idler | 0702.5 |
| Oil pump | 0106.1 | Winch worm | 2001.1 |
| Output shaft, transfer case | 0802.5 | GENERATOR | {0601.1 |
| Radiator filler cap | 0501 | | 0601.3 |
| Rear brake grease slinger | 1202 | GLASS, windshield | 1804 |
| Rocker arm cover | 0105.2 | GROMMETS | |
| Service head light door | 0609.1 | Cable, horn switch | 0611 |
| Spark plug | 0605 | Cable through dash | 0612 |
| Speedometer shaft | 2208.1 | Chassis | 0613.1 |
| Starter | 0603 | Choke and throttle controls through dash.... | 0312 |
| Steering gear horn switch | 0611 | Circuit closure cap | 0607 |
| Steering gear housing | 1401 | Connector | |
| Steering knuckle oil seal | 1004 | Auxiliary lights | 0609.2 |
| Tail light door | 0609.1 | Instrument cluster harness | 0607 |
| Thermostat housing | 0503 | Waterproof electric | 0617 |
| Timing gear cover | 0105.5 | Engine oil filter element | 0106.2 |
| Timing gear front plate | 0105.5 | Fuel tank filler neck | 0306 |
| Top cover, windshield wiper motor | 2202 | Hand brake cable through dash | 1201 |
| Transfer case cover | 0801 | Harness, light switch | 0613.1 |
| Transfer case output shaft, bearing cap | | Light | 0609.1 |
| oil seal, rear | 0802.7 | Speedometer flexible shaft | 2208.1 |
| Transfer to transmission | 0800 | Transfer gear shift lever | 1805 |
| Transmission | 0702.5 | Windshield wiper tube | 2202 |
| Transmission case | 0701 | Seat back | 1806 |
| Transmission control housing bolt | 0704 | GUARDS | |
| Transmission gear shift lever housing | 0704 | Blackout driving light | 2101 |
| Transmission retainer bearing | 0702.1 | Brake flexible hydraulic line | 1204.5 |
| Valve cover, windshield wiper motor | 2202 | Radiator | 2101 |
| Valve spring cover | 0105.1 | Tail light and trailer connection | 2101 |
| Water pump to cylinder block | 0504 | GUIDES | |
| Winch bearing cap | 2001.1 | Axle shaft | 1006 |
| Windshield | 1804 | Valve stem | 0105.1 |
| Windshield wiper motor | 2202 | HANDLES | |
| Worm gear housing cover | 2001.1 | Auxiliary light | 0609.2 |
| GEARS | | Door | 2201 |
| Differential | {1002 | Hand brake cable | 1201 |
| | 1102 | Receptacle cover | 0613.1 |
| Differential, bevel side | 1102 | Windshield wiper motor | 2202 |
| Drive, generator oil slinger | 0601.1 | HANGERS | |
| Drive, speedometer, transfer case | 0802.7 | Litter rack | 1812 |
| Driven, camshaft | 0105.5 | Winch | 2001.3 |
| Driven, engine oil pump | 0106.1 | HARNESSES | |
| Drum shaft drive, winch | 2001.1 | Instrument panel | 0607 |
| Front axle output shaft clutch | 0802.5 | Wiring, light switch | 0613.1 |
| Helical, transfer output shaft | 0802.7 | Wiring, voltage regulator | 0613.1 |
| Input shaft drive | 0802.1 | | |
| Main drive, power-take-off | 2002.1 | | |

ALPHABETICAL INDEX—Continued

| ITEM | SUBGROUP | ITEM | SUBGROUP |
|---|----------|--|---------------|
| HEADS | | HOUSINGS—Continued | |
| Engine cylinder | 0101 | Transmission gear shift lever | 0704 |
| Engine oil filter | 0106.2 | Winch clutch | 2001.1 |
| Generator end | {0601.1 | Winch worm gear | 2001.1 |
| | {0601.3 | Windshield wiper motor | 2202 |
| Starter commutator end | 0603 | | |
| HINGES | | HUBS | |
| Accelerator pedal | 0312 | Transmission second and high speed | |
| Door | 2201 | synchronizer | 0702.3 |
| Glove box | 1804 | Wheel | 1311 |
| Half, female, lid, tool box | 1808 | Winch worm gear | 2001.1 |
| Half, male, body, tool box | 1808 | | |
| Hood | {1703 | IMPELLER, water pump | 0504 |
| | {1804 | | |
| Litter rack | 1812 | INSERTS | |
| Radiator guard panel | 2101 | Brake shoe guide | 1204.3 |
| Tail gate | 1803.1 | Litter rack support | 1812 |
| Windshield | 1804 | | |
| HOLDERS | | INSULATION | |
| Brush, auxiliary light | 0609.2 | Battery | 0612 |
| Distributor breaker plate | 0604.1 | Hand brake | 1201 |
| Generator brush | 0601.3 | | |
| HOOD | | INSULATORS | |
| | 1703 | Carburetor throttle valve flange to | |
| HOOKS | | manifold | 0301 |
| Auxiliary light | 0609.2 | Generator | 0601.3 |
| Engine lifting | 0100.1 | Generator regulator | 0602 |
| Plasma container | 1812 | Generator regulator harness | 0613.1 |
| Tail gate | 1803.1 | Hand brake cable | 1201 |
| Winch cable | 2001.1 | Spark plug cable | 0605 |
| | | Starter | 0603 |
| HORN | | Starter switch | 0603 |
| | 0611 | Transfer case support | 0800 |
| HOSES | | JACKET, steering gear | |
| Air intake pipe to oil filler tube | 0304.1 | | 1401 |
| Carburetor to air cleaner pipe | 0304.1 | JETS | |
| Carburetor housing pipe to oil filler tube..... | 0304.1 | Carburetor body | 0301 |
| Flexible, brake line | 1204.5 | Carburetor metering rod | 0301 |
| Radiator, upper | 0503 | Fitting, oil, timing gear | 0106.6 |
| Radiator water outlet | 0503 | | |
| Rocker arm cover to oil filler tube..... | 0304.1 | JOINT, universal winch | 2001.3 |
| Underwater vent system | 0304.5 | | |
| HOUSINGS | | JOURNAL, universal joint | |
| Axle | {1001 | | 0900 |
| | {1101 | KEYS | |
| Blackout marker light | 0609.1 | Axle shaft, rear | 1104.1 |
| Carburetor metering rod diaphragm | 0301 | Clutch shifting lever, winch | 2001.5 |
| Carburetor pump diaphragm | 0301 | Drive shaft, winch | 2001.3 |
| Flywheel | 0103 | Hanger bearing shaft, winch | 2001.3 |
| Head light | 0609.1 | Generator | {0601.1 |
| Power-take-off | 2002.1 | | {0601.3 |
| Starter | 0603 | Lower shaft, power-take-off | 2002.1 |
| Steering gear | 1401 | Sprocket, power-take-off | 2002.1 |
| Tail light | 0609.1 | Winch | 2001.1 |
| Thermostat | 0503 | Worm brake, winch drum | 2001.1 |
| | | Worm gear, winch | 2001.1 |
| | | KICKER, valve, windshield wiper motor | 2202 |

ALPHABETICAL INDEX—Continued

| ITEM | SUBGROUP | ITEM | SUBGROUP |
|---|----------|--|------------------------|
| KNOBS | | LINES | |
| Choke control | 0312 | Brake | 1204.5 |
| Shift lever, power-take-off control | 2002.5 | Carburetor to fuel pump | 0306 |
| Throttle control | 0312 | Crankcase to cylinder head | 0106.6 |
| Transfer gear shift lever | 0804 | Flexible, engine oil filter | 0106.6 |
| Transmission gear shift lever | 0704 | Flexible, fuel line to fuel pump | 0306 |
| KNUCKLE, steering | 1004 | Fuel, elbow to tee | 0306 |
| LAMPS | | Fuel tank to elbow | 0306 |
| Auxiliary lights | 0609.2 | Fuel, tee to shut-off valve | 0306 |
| Instrument panel | 0607 | Fuel, valve to fuel pump hose | 0306 |
| Unit, sealed beam | 0609.1 | Oil sending unit | 0106.6 |
| LATCHES | | Vacuum pump to tee | 0306 |
| Towing pintle | 1503 | Vent system, underwater | 0304.5 |
| Winch power-take-off | 2002.5 | Windshield wiper to tee | 2202 |
| LEADS | | LINERS | |
| Distributor, breaker lever to coil | 0604.1 | Body sill | 1501 |
| Engine ground | 0615 | Radiator guard | 2101 |
| Generator connecting brush | 0601.3 | Windshield to hood bumper | 1804 |
| Generator regulator | 0602 | LININGS | |
| LEG, seat support | 1806 | Brake drum | 2001.1 |
| LENSES | | Brake shoe | 1202 |
| Blackout tail light | 0609.1 | LINKS | |
| Instrument panel and high beam lights | 0607 | Connector, accelerator | 0312 |
| Tail and stop light, red | 0609.1 | Fuel pump priming lever | 0302.1 |
| LEVERS | | Fuel pump rocker arm | 0302.1 |
| Accelerator bellcrank | 0312 | Stabilizer | 1605 |
| Engine | | Steering drag | 1401 |
| Clutch control | 0202 | Winch cable chain | 2001.1 |
| Clutch release pressure spring | 0202 | LOCKS | |
| Fuel pump primer | 0302.1 | Carburetor choke valve to poppet | |
| Gear shift, transfer | 0804 | valve plug | 0301 |
| Gear shift, transmission | 0704 | Gear shifter shaft | 0804 |
| Hand brake | 1201 | Glove box door | 1808 |
| Ignition switch | 0607 | Tail gate | 1803.1 |
| Shift, power-take-off control | 2002.5 | Towing pintle | 1503 |
| Shifting, winch clutch | 2001.5 | Valve spring retainer | 0105.1 |
| Starter clutch shifting yoke | 0603 | Windshield | 1804 |
| Transfer gear shift | 0804 | LOOMS | |
| LIDS | | Cable | 0613.1 |
| Battery box | 0612 | Fuel gage cable | 0613.1 |
| Case, auxiliary light | 0609.2 | Fuel tank lines | 0306 |
| Stowage compartment | 1812 | Tube, vent | 0304.5 |
| Tool box | 1808 | LOOP, footman | { 1703 1804 1808 |
| LIGHTS | | MANIFOLD, exhaust | 0108 |
| Auxiliary | 0609.2 | MARKERS | |
| Blackout marker | 0609.1 | Circuit | 0607 |
| Head, blackout, sealed beam | 0609.1 | Conduit | 0613.1 |
| Head, service | 0609.1 | Reel lamp cable | 0609.2 |
| Head light high beam indicator | 0607 | MIRROR, rear view | 2202 |
| Instrument cluster | 0607 | MOTOR, windshield wiper | 2202 |
| Instrument panel | 0607 | | |
| Rear curtain | 2201 | | |

ALPHABETICAL INDEX—Continued

| ITEM | SUBGROUP | ITEM | SUBGROUP |
|---|----------|--|----------|
| MOUNTING, head light | 0609.1 | NUTS—Continued | |
| MUFFLER, exhaust | 0401 | Weld—Continued | |
| NECK, radiator filler | 0501 | Glove box panel | 1808 |
| NEEDLE, carburetor needle valve | 0301 | Hood panel | 1703 |
| NIPPLES | | Radiator guard | 2101 |
| Hose, vent valve hose connection | 0304.5 | Top bow stowage | 1808 |
| Vent valve | 0304.5 | Windshield wiper arm to shaft | 2202 |
| Water pump by-pass | 0503 | OUTRIGGER, body | 1501 |
| NUTS | | PACKINGS | |
| Auxiliary light | 0609.2 | Commutator end head and pinion housing | 0603 |
| Axle shaft | 1104.1 | Crankshaft bearing cap | 0102.2 |
| Battery box and post | 0612 | Drive end bearing inner retainer | 0601.1 |
| Body mounting | 1801 | "O" Ring | |
| Body panel | 1804 | Distributor | 0604.1 |
| Bow, top storage bracket, front | 1808 | Generator | {0601.1 |
| Clinch, head light mounting rings | 2101 | Generator regulator | 0602 |
| Connecting rod cap | 0104.2 | Starter | 0603 |
| Cover plate to dash and front panel | 1804 | Oil, valve spring retainer | 0105.1 |
| Engine oil filter head mounting | 0106.2 | Preformed, drive pinion oil seal | 1102 |
| Fan and generator pulley drive | 0102.1 | PADS | |
| Flared tube | 0304.5 | Brake pedal | 1206 |
| Frame | 1501 | Clutch pedal | 0202 |
| Front axle pinion | 1002 | Crash, seat frame | 1806 |
| Front axle steering knuckle bolt | 1004 | Draft, clutch pedal | 0202 |
| Front hub bearing | 1311 | Mounting light | 0609.1 |
| Generator plate brush | 0601.3 | Seat | 1806 |
| Generator regulator | 0602 | Seat back | 1806 |
| Hood catch "U" bolt | 1703 | Seat springs | 1806 |
| Ignition switch | 0607 | Wheelhouse cushion | 1812 |
| Input shaft drive gear | 0802.1 | PADDLE, windshield wiper motor | 2202 |
| Marker, blackout mounting | 0609.1 | PANE, rear curtain | 2201 |
| Mirror | 2202 | PANS | |
| Pitman shaft adjusting screw | 1401 | Floor | 1805 |
| Power-take-off | 2002.1 | Oil, engine | 0106.6 |
| Propeller shaft to transfer yoke | 0802.5 | Seat | 1806 |
| Propeller shaft yoke | 1102 | PANELS | |
| Retaining | {0613.1 | Battery box | 0612 |
| Shovel blade retainer | }0617 | Body | 1804 |
| Socket, top bow | 1808 | Body cowl | 1804 |
| Spark plug cable | 2201 | Floor | 1805 |
| Spring | 0605 | Instrument | 1804 |
| Starter | {1601.1 | Seat back | 1806 |
| Starter terminal stud | }1601.3 | Stowage compartment lid | 1808 |
| Steering bellcrank shaft | 0603 | Tool box, front floor | 1808 |
| Steering wheel | 1401 | Wheelhouse | 1804 |
| Strainer, fuel inlet | 1401 | PAWL | |
| Tail light and trailer connection guard | 0301 | Hand brake ratchet stop | 1201 |
| Transfer case (rear axle output shaft flange) | 2101 | Ratchet, auxiliary light | 0609.2 |
| Weld | | PEDALS | |
| Body side panel | 0802.7 | Accelerator | 0312 |
| Floor pan and dash panel | 1804 | Brake | 1206 |
| Front fender | 1805 | Clutch | 0202 |
| | 1701 | Starter switch | 0603 |

ALPHABETICAL INDEX—Continued

| ITEM | SUBGROUP | ITEM | SUBGROUP |
|---|----------|--|----------|
| PILLAR, cowl | 1804 | PIPES | |
| PINS | | Exhaust | 0401 |
| Brake shoe hold-down spring | 1202 | Oil filter, crankcase ventilator | 0106.5 |
| Cable, distributor to spark plug | 0605 | Underwater vent system air intake | 0304.5 |
| Carburetor intake needle spring | 0301 | PISTONS | |
| Carburetor metering rod sleeve | 0301 | Brake master cylinder | 1204.1 |
| Clevis, lifting shackle | 1503 | Brake wheel cylinder | 1204.3 |
| Clutch release mechanism clevis | 0202 | Engine | 0104.1 |
| Crankshaft bearing dowel | 0102.2 | PIVOTS | |
| Flywheel dowel | 0103 | Front seat hinge | 1806 |
| Front axle universal joint | 1006 | Top bow | 2201 |
| Generator brush plate | 0601.3 | PLATES | |
| Hand brake anchor | 1201 | Auxiliary light | 0609.2 |
| Hinge | | Backing, front and rear brake | 1202 |
| Glove box door | 1808 | Baffle, blackout tail and stop light | 0609.1 |
| Tail gate | 1803.1 | Camshaft thrust | 0105.3 |
| Tool box lid | 1808 | Carburetor choke valve | 0301 |
| King | 1004 | Carburetor throttle valve | 0301 |
| Latch, winch power-take-off | 2002.5 | Clinch, blackout tail light door lower lens..... | 0609.1 |
| Locking | | Cover | |
| Differential pinion shaft | {1002 | Dash panel | 1804 |
| | }1102 | Floor pan | 1805 |
| King pin | 1004 | Power-take-off shift | 1805 |
| Litter rack | 1812 | Trailer receptacle opening | 1804 |
| Oil pump driven gear | 0106.1 | Data, name, caution, instruction, etc. | 2210 |
| Oil pump rotor | 0106.1 | Deep water fording vent valve | 2210 |
| Piston | 0104.1 | Distributor breaker | 0604.1 |
| Pivot | | Engine, mounting, front | 0105.5 |
| Clutch pressure spring release lever | 0202 | Engine rear | 0103 |
| Front passenger seat | 1806 | Floor, transmission | 1805 |
| Generator oil slinger | 0601.1 | Fuel filter cover | 0309 |
| Transfer gear shift lever | 0804 | Fuel filter upper and lower end | 0309 |
| Radiator guard hinge | 2010 | Fuel pump covering pulsator diaphragm | 0302.1 |
| Ratchet, auxiliary light | 0609.2 | Fuel pump vacuum section | 0302.1 |
| Rear axle shaft nut | 1104.1 | Gas tank unit | 1805 |
| Retaining, chain | 2201 | Generator | {0601.1 |
| Rocker arm, fuel pump | 0302.1 | | }0601.3 |
| Seat frame | 1806 | Generator regulator | 0602 |
| Shift lever, power-take-off, shifter | | Ignition switch | 0607 |
| shaft end | 2202.5 | Instrument panel | 0607 |
| Swivel, control wire, crankcase | | Lock, | |
| ventilation valve | 0304.5 | Countershaft | 0802.3 |
| Towing pintle hook latch | 1503 | Differential drive gear | 1102 |
| Towing pintle hook lock | 1503 | Front axle differential | 1002 |
| Transmission gear shift fork | 0704 | Transmission idler shaft and countershaft.. | 0702.5 |
| Transmission gear shift lever fulcrum ball..... | 0704 | Motor heater cutout access | 1805 |
| Winch guide vertical roller | 2001.1 | Pressure, clutch | 0201 |
| Windshield | | Reinforcement, frame | 1501 |
| Hinge | 1804 | Retracting spring clip | 0312 |
| Hood catch | 1804 | Shift lever, power-take-off control | 2002.5 |
| Wiper motor handle | 2202 | Shifting, transmission second and high | |
| PINIONS | | speed synchronizer | 0702.3 |
| Differential, front axle | 1002 | Skid, frame | 1501 |
| Differential, rear axle | 1102 | Socket, blackout tail and stop light | 0609.1 |
| PINTLE, towing | 1503 | Spare wheel | 1504 |

ALPHABETICAL INDEX—Continued

| ITEM | SUBGROUP | ITEM | SUBGROUP |
|---|----------|---|----------|
| PLATES—Continued | | PLUGS—Continued | |
| Spreader arm | 1812 | Pipe—Continued | |
| Spring shackle | {1601.1 | Fuel tank and lines | 0306 |
| | {1601.3 | Starter | 0603 |
| Stabilizer bar | 1605 | Steering gear housing | 1401 |
| Starter | 0603 | Water pump | 0504 |
| Steering column | 1805 | Power-take-off cover and housing | 2002.1 |
| Support, litter rack | 1812 | Radio cable hole in battery box | 0612 |
| Supporting, air deflector | 0502 | Rocker arm shaft | 0105.2 |
| Tapping | | Shifter shaft interlock hole | 0704 |
| Hood hinge | 1804 | Spark | 0605 |
| Radiator guard hinge | 2101 | Starter | 0603 |
| Rear view mirror | 1804 | Steering | |
| Windshield clamp catch | 1804 | Gear drag link ball seat | 1401 |
| Windshield hinge | 1804 | Gear housing | 1401 |
| Toe board | 1805 | Gear reducer | 1401 |
| Tool box lid | 1805 | Knuckle | 1004 |
| Transfer case bolt | 1805 | Taper, transmission, interlock plunger hole... | 0704 |
| Windshield wiper motor | 2202 | Transfer case pipe | 0801 |
| PLUGS | | Transfer case shifter shaft poppet | |
| Air cleaner to dash elbow tube | 0304.1 | ball spring | 0804 |
| Blackout marker light cable hole | 0609.1 | Transmission case filler | 0701 |
| Brake master cylinder | 1204.1 | Universal joint journal | 0900 |
| Breather, winch | 2001.1 | Winch gear housing | 2001.1 |
| Carburetor | | PLUNGERS | |
| Choke shaft | 0301 | Engine oil pump relief | 0106.1 |
| Idle passage | 0301 | Interlock, transmission gear shift rail | 0704 |
| Intake needle passage | 0301 | Poppet, winch | 2001.5 |
| Passage | 0301 | POINTER, flywheel timing indicator | |
| Pump inlet passage | 0301 | 0103 | |
| Strainer passage | 0301 | POINT SET, distributor | |
| Throttle shaft expansion | 0301 | 0604.1 | |
| Cylinder block | 0101 | POWER PLANT | |
| Dash and instrument panel | 1804 | 0100.1 | |
| Distributor | 0604.1 | POWER-TAKE-OFF | |
| Drain | | 2002.1 | |
| Engine oil pan | 0106.6 | PRECLEANER, air cleaner | |
| Oil, front axle | 1001 | 0304.1 | |
| Oil, rear axle | 1101 | PULLEYS | |
| Drive end head | 0601.1 | Auxiliary light | 0609.2 |
| Driver's seat frame | 1806 | Drive, fan and generator | 0102.1 |
| Engine oil filter drain | 0106.2 | Driven, fan and water pump | 0505 |
| Expansion | | Generator | {0601.1 |
| Camshaft | 0105.3 | | {0601.3 |
| Shift rail hole | 0704 | PUMPS | |
| Steering gear and horn adapter | 1401 | Fuel | 0302.1 |
| Filler, oil, front axle | 1001 | Oil | 0106.1 |
| Filler, oil, rear axle | 1101 | Water | 0504 |
| Floor pan | 1805 | RACES | |
| Flywheel housing | 0103 | Front axle universal joint | 1006 |
| Fuel tank drain | 0306 | Intermediate bearing | 2001.1 |
| Generator field coil frame inspection | 0601.3 | Steering column bearing | 1401 |
| Generator regulator | 0602 | Universal joint | 0900 |
| Glove box drain | 1808 | RACKS, litter | |
| Oil pipe generator drive end head | 0601.1 | 1812 | |
| Pipe | | RADIATOR | |
| Distributor | 0604.1 | 0501 | |
| | | RAILS | |
| | | Hand, safety, front passenger | 2101 |
| | | Top | 2201 |

ALPHABETICAL INDEX—Continued

| ITEM | SUBGROUP | ITEM | SUBGROUP |
|--|----------|--|----------|
| RATCHET, auxiliary light | 0609.2 | RETAINERS—Continued | |
| RECEPTACLES | | Grease, | |
| Distributor | 0604.1 | Clutch housing bearing | 2001.1 |
| Generator regulator | 0602 | Power-take-off shift lever | 2002.5 |
| Generator wiring harness | {0601.1 | Winch drum | 2001.1 |
| | {0601.3 | Horn button cap | 0611 |
| Trailer coupling | 0617 | Litter rack | 1812 |
| RECTIFIER, generator regulator..... | 0602 | Nut | 2101 |
| REFLECTORS | | Rear, | |
| Auxiliary light | 0609.2 | Axle bearing | 1104.1 |
| Body | 2202 | Seat frame spring | 1806 |
| REGULATOR, generator..... | 0602 | Seat pivot tube | 1806 |
| REINFORCEMENTS | | Shovel blade | 1808 |
| Battery box | 0612 | Spring shackle grease seal | {1601.1 |
| Body cowl | 1804 | | {1601.3 |
| Body side panel | 1804 | Stabilizer bar | 1605 |
| Brace, fender | 1701 | Starter | 0603 |
| Engine plate | 0103 | Steering knuckle | 1004 |
| Frame | 1501 | Tapping plate, radiator guard hinge..... | 2101 |
| Frame, towing pintle | 1503 | Tool box lid ring | 1808 |
| Hood catch | 1804 | Top to windshield frame | 1804 |
| Hood panel | 1703 | Transfer output shaft bearing | 0802.5 |
| Hose, water line | 0503 | Transmission | 0702.1 |
| Machine gun support | 1501 | Transmission gear shift lever housing..... | 0704 |
| Passenger seat safety rail | 1804 | Valve, | |
| Rear spring shackle bracket | 1501 | Metering, vent, crankcase | 0304.5 |
| Spare wheel mounting bolt | 1804 | Spring | 0105.1 |
| Towing pintle | 1503 | Windshield wiper motor | 2202 |
| RESISTORS | | RINGS | |
| Generator regulator | 0602 | Air intake support | 0304.5 |
| Instrument cluster | 0607 | Block, auxiliary light | 0609.2 |
| RESTS | | Blocking, transmission second and | |
| Foot, accelerator | 0312 | high speed synchronizer | 0702.3 |
| Wheelhouse seat | 1812 | Engine oil filter reinforcing | 0106.2 |
| RETAINERS | | Gear shift lever housing cover | 1805 |
| Air cleaner | 0304.1 | Locking, brake master cylinder | 1204.1 |
| Axe blade | 1808 | Piston | 0104.1 |
| Body cowl | 1804 | Retaining, | |
| Brake master cylinder | 1204.1 | Brake lines | 1204.5 |
| Clutch auxiliary spring | 0202 | Distributor | 0604.1 |
| Clutch control tube spring | 0202 | Towing pintle lock pin | 1503 |
| Door curtain | 1804 | Service head light lamp | 0609.1 |
| Engine oil pump relief plunger spring..... | 0106.1 | Starter retainer and pinion stop | 0603 |
| Fender to radiator guard | 1701 | Steering gear bearing | 1401 |
| Front axle universal joint shaft..... | 1006 | Snap, | |
| Fuel pump, | | Front axle | 1006 |
| Diaphragm return spring | 0302.1 | Transfer clutch gear shaft bearing..... | 0802.5 |
| Main body oil seal | 0302.1 | Transfer output shaft thrust washer | 0802.5 |
| Vacuum section screen | 0302.1 | Transmission input shaft bearing | 0702.1 |
| Valve fuel section | 0302.1 | Transmission second and high speed | |
| Valve vacuum section | 0302.1 | synchronizer hub | 0702.3 |
| Generator | 0601.1 | Universal joint journal bearing | 0900 |
| Glove box door lock | 1808 | Thumb screw chain | 2201 |
| | | Timing gear cover packing | 0105.5 |
| | | Tool box lid | 1808 |
| | | RING SET, piston | 0104.1 |

ALPHABETICAL INDEX—Continued

| ITEM | SUBGROUP | ITEM | SUBGROUP |
|--|----------|---|----------|
| RISER, front to rear floor | 1805 | SCREWS—Continued | |
| RIVETS | | Hood hinge | 1804 |
| Auxiliary light | 0609.2 | Instrument panel to rear cowl and cowl pillar | 1804 |
| Facing, clutch | 0201 | Litter rack | 1812 |
| Generator | 0601.3 | Master brake cylinder inspection cover | 1805 |
| Mounting, data plates | 2210 | Motor heater cutout plate | 1805 |
| Mounting, head and tail light | 0609.1 | Mounting, data plates | 2210 |
| RODS | | Radiator guard | 2101 |
| Accelerator bellcrank link | 0312 | Radiator guard panel hinge | 2101 |
| Carburetor metering | 0301 | Rear axle differential | 1100 |
| Clutch release | 0202 | Rear top bow socket | 2201 |
| Connecting | 0104.2 | Rear view mirror extension arm | 2202 |
| Connector, accelerator | 0312 | Rear view mirror extension arm clamp | 2202 |
| Fuel pump push | 0302.1 | Seat retaining bracket | 1806 |
| Hand brake lever | 1201 | Set, winch | 2001.3 |
| Litter rack | 1812 | Set (winch control) | 2001.5 |
| Push, brake master cylinder | 1204.1 | Set, winch worm brake | 2001.5 |
| Push, horn switch | 0611 | Shoulder, marker light | 0609.1 |
| Radiator support | 0501 | Spare wheel support | 1504 |
| Side curtain | 2201 | Starter | 0603 |
| Throttle, accelerator | 0312 | Starter shifting yoke shaft retainer | 0603 |
| Tie, steering gear | 1401 | Steering column plate | 1805 |
| Valve push | 0105.2 | Steering knuckle oil seal | 1004 |
| ROLLERS | | Stowage bracket | 1808 |
| Transmission countershaft gear bearing | 0702.5 | Thumb | 2201 |
| Universal joint | 0900 | Toe board plate | 1805 |
| Winch, vertical | 2001.1 | Transfer case bolt plate | 1805 |
| ROTORS | | Transfer case output shaft, rear | 0802.7 |
| Distributor | 0604.1 | Transfer case shifter shaft fork | 0804 |
| Engine oil pump | 0106.1 | Transmission gear shift lever housing | 0704 |
| SCREEN, fuel pump vacuum section | 0302.1 | Valve rocker arm | 0105.2 |
| SCREWS | | Valve tappet | 0105.2 |
| Adjusting, | | Windshield wiper motor plate | 2202 |
| Carburetor idle | 0301 | Windshield wiper motor valve cover | 2202 |
| Carburetor throttle lever | 0301 | SEALS | |
| Pitman shaft | 1401 | Accelerator pedal rod | 0312 |
| Winch worm brake | 2001.1 | Body | 1800 |
| Auxiliary light | 0609.2 | Carburetor choke shaft | 0301 |
| Crankcase ventilation valve | 0304.5 | Carburetor throttle shaft dust | 0301 |
| Crankshaft bearing cap | 0102.2 | Carburetor idle adjusting screw | 0301 |
| Cylinder head | 0101 | Clutch release cable | 0202 |
| Engine oil filter head mounting | 0106.2 | Distributor | 0604.1 |
| Engine oil pump body cover | 0106.1 | Drive shaft, winch | 2001.3 |
| Floor pan cover plate | 1805 | Dust, | |
| Floor, transmission plate | 1805 | Clutch control tube | 0202 |
| Front axle, | | Steering drag link | 1401 |
| Differential | 1002 | Universal joint bearing | 0900 |
| Shaft drive flange | 1006 | Fuel, | |
| Steering knuckle | 1004 | Pump oil priming lever pin | 0302.1 |
| Fuel filter cover plate | 0309 | Pump vacuum section | 0302.1 |
| Fuel level gage unit | 0610 | Tank drain plug | 0306 |
| Generator brush lead cable | 0601.1 | Grease, | |
| Generator regulator | 0602 | Axle shaft | 1311 |
| Head light focusing | 0609.1 | Power-take-off main drive shaft | 2002.1 |
| | | Winch drum shaft | 2001.1 |
| | | Winch hanger bearing | 2001.3 |

ALPHABETICAL INDEX—Continued

| ITEM | SUBGROUP | ITEM | SUBGROUP |
|--|----------|---|----------|
| SHIMS—Continued | | SPACERS—Continued | |
| King pin bearing | 1004 | Lifting shackle bracket | 1503 |
| Rear axle differential bearing | 1102 | Litter rack | 1812 |
| Rear axle shaft bearing | 1104.1 | Rear view mirror pivot clamp | 2202 |
| Steering gear housing | 1401 | Snow plow bolt | 1501 |
| Transfer output shaft rear bearing cap..... | 0802.7 | Spare gasoline can bracket | 1808 |
| SHOES | | Spare wheel support | 1504 |
| Brake | 1202 | Spring clip | { 1601.1 |
| Hand brake | 1201 | | { 1601.3 |
| Pole, generator | 0601.3 | Steering gear | 1401 |
| SHROUD, radiator | | Transmission countershaft bearing | 0702.5 |
| | 0502 | Transmission main shaft bearing | 0702.3 |
| SILL, cross, rear floor pan..... | | Windshield wiper motor plate to housing..... | 2202 |
| | 1805 | Windshield wiper motor to windshield | 2202 |
| SLEEVES | | SPEEDOMETER | |
| Auxiliary light cables | { 0609.1 | | 2208.1 |
| | { 0609.2 | SPINDLE, front axle wheel bearing..... | |
| Carburetor choke valve | 0301 | | 1004 |
| Connector cover | 0613.1 | SPRINGS | |
| Connector cover light cables | 0609.1 | Accelerator bellcrank | 0312 |
| Generator field lead | 0601.1 | Accelerator pedal hinge | 0312 |
| Spark plug cable | 0605 | Auxiliary light | 0609.2 |
| Speedometer driven gear | 2208.1 | Blackout sealed beam unit | 0609.1 |
| Tail light socket | 0609.1 | Brake pedal | 1206 |
| Tire valve mounting | 1313 | Brake shoe retracting | 1202 |
| Transmission second and high speed | | Carburetor, | |
| synchronizer | 0702.3 | Choke valve | 0301 |
| Wire, trailer | 0617 | Choke valve shaft | 0301 |
| SLINGERS | | Idle adjusting screw | 0301 |
| Dust, transfer companion flange and | | Intake needle | 0301 |
| front yoke | 0802.5 | Metering rod | 0301 |
| Grease, rear brake | 1202 | Pump | 0301 |
| Oil, | | Catch, hood to windshield | 1804 |
| Crankshaft | 0102.1 | Clutch, | |
| Differential drive pinion bearing | { 1002 | Auxiliary pressure | 0202 |
| | { 1102 | Pedal shank draft pad | 0202 |
| Generator drive end head | 0601.1 | Pressure | 0202 |
| SNUBBER, transfer case support insulator..... | | Release bearing carrier | 0202 |
| | 0800 | Compression, spark plug cable connector..... | 0605 |
| SOCKETS | | Connector, trailer socket | 0617 |
| Rear top bow | 2201 | Distributor | 0604.1 |
| Side curtain | 2201 | Drum brake lining | 2001.1 |
| Tail light | 0609.1 | Engine oil filter cover bolt | 0106.2 |
| SPACERS | | Front | 1601.1 |
| Bearing (main drive gear) power-take-off.... | 2002.1 | Fuel pump fuel section diaphragm | 0302.1 |
| Camshaft thrust plate | 0105.3 | Fuel pump rocker arm | 0302.1 |
| Clutch, winch | 2001.1 | Fuel pump vacuum sectional diaphragm..... | 0302.1 |
| Crankcase oil filler pipe bracket..... | 0106.5 | Generator brush | 0601.3 |
| Distributor cam | 0604.1 | Generator regulator | 0602 |
| Fan pulley shield | 0102.1 | Hand brake | 1201 |
| Fuel pump rocker arm link | 0302.1 | Head light mounting unit | 0609.1 |
| Fuel pump to cylinder block | 0302.1 | Instrument cluster | 0607 |
| Gear, camshaft | 0105.5 | Light switch harness | 0613.1 |
| Gear, crankshaft | 0105.5 | Metering valve, vent, crankcase | 0304.5 |
| Generator drive end | { 0601.1 | Oil pump relief plunger | 0106.1 |
| | { 0601.3 | Poppet, power-take-off control | 2002.5 |
| | | Rear | 1601.3 |
| | | Receptacle cover | 0613.1 |

ALPHABETICAL INDEX—Continued

| ITEM | SUBGROUP | ITEM | SUBGROUP |
|---|---------------|--|---------------|
| SPRINGS—Continued | | STRAPS—Continued | |
| Retaining, water pump bearing | 0504 | Storage—Continued | |
| Retracting, | | Litter rack | 1806 |
| Accelerator pedal | 0312 | Seat | 1808 |
| Clutch pedal | 0202 | Shovel | 1808 |
| Hand brake | 1201 | Top | 1808 |
| Return, brake master cylinder | 1204.1 | Web, deck to front bow | 2201 |
| Return, brake wheel cylinder piston | 1204.3 | Web, hold-down, top | 2201 |
| Rocker arm shaft | 0105.2 | STRIKER, glove compartment door..... | 1804 |
| Seat | 1806 | STUDS | |
| Service head light door gasket..... | 0609.1 | Auxiliary light | 0609.2 |
| Starter | 0603 | Ball, engine clutch control tube..... | 0202 |
| Steering, | | Body mounting | 1801 |
| Gear bellcrank to bracket dust seal..... | 1401 | Clutch release fork | 0202 |
| Gear drag link ball seat | 1401 | Eye, air cleaner | 0304.1 |
| Jacket upper spring | 1401 | Instrument cluster mounting plate | 0607 |
| Knuckle oil seal | 1004 | Manifold | 0108 |
| Tie rods end studs | 1401 | Mounting, wiring harness | 0607 |
| Tail light socket | 0609.1 | Rocker arm cover | 0105.2 |
| Tension, brake cable | 1201 | Rocker arm shaft support | 0101 |
| Towing pintle latch | 1503 | Spare wheel | 1504 |
| Transfer gear shift lever | 0804 | Starter switch terminal | 0603 |
| Transfer shifter shaft poppet ball..... | 0804 | Top hold-down | 2201 |
| Transmission, | | Wheel hub | 1311 |
| Gear shift lever support | 0704 | SUMP, engine oil filter..... | 0106.2 |
| Gear shift shaft poppet ball..... | 0704 | SUPPORTS | |
| Synchronizer | 0702.3 | | |
| Valve | 0105.1 | Auxiliary litter | { 1806 |
| Winch poppet | 2001.4 | | { 1808 |
| Windshield wiper motor | 2202 | | { 1812 |
| SPROCKET, power-take-off | 2002.1 | Blackout marker light socket | 0609.1 |
| STARTER | 0603 | Engine oil strainer | 0106.6 |
| STOPS | | Engine rear end plate | 0103 |
| Litter, rack | 1812 | Generator mounting | { 0601.1 |
| Litter, tail gate | 1803.1 | | { 0601.3 |
| Throttle control wire | 0312 | Litter, tail gate | 1803.1 |
| Transmission brake | 1201 | Machine gun | 1501 |
| STRAINERS | | Mounting, voltage regulator | 1501 |
| Body panel to frame | 1804 | Muffler and exhaust pipe..... | 1808 |
| Carburetor fuel intake | 0301 | Oil pressure sending unit | 0610 |
| Carburetor pump | 0301 | Radiator guard panel | 1501 |
| Engine oil | 0106.6 | Seal, flywheel housing | 0202 |
| Fuel tank filter | 0306 | Spare wheel | 1504 |
| STRAPS | | Spare wheel well | 1808 |
| Axe | 1808 | Starter | 0603 |
| Battery box hold-down | 0612 | Top bow stabilizer board | 1808 |
| Fuel tank hold-down | 0306 | SWITCHES | |
| Generator regulator ground | 0602 | Auxiliary light | 0609.2 |
| Hold-down, windshield | 1808 | Head light dimmer | 0608 |
| Litter hold-down | 1808 | Horn | 0611 |
| Lock, differential drive gear | 1102 | Ignition | 0607 |
| Spare gas can | 1808 | Light | 0607 |
| Stowage, | | Starter | 0603 |
| Curtain | 2201 | Stop light | 0608 |
| Door | 2201 | SYNCHRONIZER, transmission second and | |
| | | high speed | 0702.3 |

ALPHABETICAL INDEX—Continued

| ITEM | SUBGROUP | ITEM | SUBGROUP |
|--|----------|---|----------|
| TAIL GATE, body | 1803.1 | UNION, flared tube inverted | 0304.5 |
| TANKS | | UNITS | |
| Fuel | 0306 | Sending | |
| Supply, brake master cylinder | 1204.1 | Fuel level | 0610 |
| TAPE, insulating | 0609.1 | Oil pressure | 0610 |
| TAPPET, valve | 0105.2 | Water temperature | 0610 |
| TEES | | VALVES | |
| Battery box drain tube | 0612 | Air, front axle ventilation | 1005.5 |
| Brake line | 1204.5 | Air, rear axle ventilation | 1105.5 |
| Flared tube | 0306 | Bleeder, brake wheel cylinder | 1204.3 |
| Vacuum tube to manifold | 0106.5 | Carburetor needle | 0301 |
| Vent tube to reducing elbow | 0304.5 | Check, brake master cylinder | 1204.1 |
| Windshield wiper line | 2202 | Control | 0304.5 |
| TERMINALS | | Control, crankcase ventilator | 0106.5 |
| Auxiliary light | 0609.2 | Fuel pump fuel and vacuum section | 0302.1 |
| Battery | 0612 | Fuel tank | 0304.5 |
| Chassis wiring | 0613.1 | Intake and exhaust | 0105.1 |
| Distributor | 0604.1 | Metering, vent, crankcase | 0304.5 |
| Generator regulator | 0602 | Oil pump relief | 0106.1 |
| Generator regulator harness | 0613.1 | Plug, fuel shut-off | 0306 |
| Head and tail lights | 0609.1 | Shut-off | |
| Horn switch | 0611 | Crankcase ventilation | 0304.5 |
| Instrument cluster panel | 0607 | Fuel line | 0306 |
| Starter switch | 0603 | Windshield wiper | 2208.1 |
| Trailer receptacle | 0617 | Slide valve, windshield wiper motor | 2202 |
| THERMOSTAT, water temperature | 0503 | VENTS | |
| THROWER, oil, generator drive end head | 0601.1 | Air, front axle ventilation | 1005.5 |
| TIP, strap end | {1808 | Air, rear axle ventilation | 1105.5 |
| | }2201 | Fuel tank | 0304.5 |
| TIRE, pneumatic | 1313 | VENTILATOR, crankcase | 0106.5 |
| TRANSFER | 0800 | WASHERS | |
| TRANSMISSION | 0700 | Accelerator bellcrank lever | 0312 |
| TRANSMITTER, sending, fuel level | 0610 | Air cleaner | 0304.1 |
| TRAY, battery box | 0612 | Auxiliary light | 0609.2 |
| TRIM, seat | 1806 | Bearing, blackout head light | 0609.1 |
| TUBES | | Body mounting | 1801 |
| Battery tray drain | 0612 | Brake master cylinder | 1204.1 |
| Carburetor bleeder | 0301 | Brake pedal shaft | 1206 |
| Carburetor low speed jet | 0301 | Brake pedal shank draft pad | 0202 |
| Pneumatic tire | 1313 | Brake pedal shank drive pad | 1206 |
| Steering gear | 1401 | Camshaft driven gear | 0105.5 |
| Steering tie rod | 1401 | Clutch pedal shaft | 0202 |
| Windshield wiper | 2202 | Crankcase ventilation valve | 0304.5 |
| TUBING | | Curtain fastener | 2201 |
| Air cleaner | 0304.1 | Cylinder head | 0101 |
| Brake line | 1204.5 | Distributor | 0604.1 |
| Engine oil lines | 0106.6 | Felt, differential drive pinion | 1102 |
| Fuel tank lines | 0306 | Fender brace | 1701 |
| Underwater vent system | 0304.5 | Front axle pinion nut | 1002 |
| | | Fuel pump rocker arm link spacer | 0302.1 |
| | | Fuel pump to cylinder block | 0302.1 |
| | | Generator | {0601.1 |
| | | | }0601.3 |
| | | Generator regulator | 0602 |
| | | Input shaft drive gear | 0802.1 |

ALPHABETICAL INDEX—Continued

| ITEM | SUBGROUP | ITEM | SUBGROUP |
|--|----------|--|----------|
| WASHERS—Continued | | WASHERS—Continued | |
| Instrument panel mounting stud | 0607 | Wheel bearing | 1311 |
| Lock, rear axle differential | 1102 | Windshield wiper motor | 2202 |
| Mirror extension arm | 2202 | WEATHERSEAL, windshield glass | |
| Mounting, harness | 0607 | 1804 | |
| Oil pump mounting | 0106.1 | WEATHERSTRIPS | |
| Pivot, rear mirror clamp | 2202 | Battery box door | 0612 |
| Power-take-off | 2002.1 | Glove box door | 1808 |
| Propeller shaft to transfer yoke | 0802.5 | Stowage compartment lid | 1808 |
| Propeller shaft yoke | 1102 | Tool box lid | 1808 |
| Rear axle shaft | 1104.1 | Windshield | 1804 |
| Rear body panel | 1804 | WEIGHTS | |
| Retaining | | Carburetor pump discharge ball | 0301 |
| Carburetor choke valve shaft seal | 0301 | Distributor governor | 0604.1 |
| Carburetor idle adjusting screw seal | 0301 | WELL, gas tank | |
| Carburetor throttle shaft | 0301 | 1805 | |
| Carburetor throttle valve shaft seal | 0301 | WHEELS | |
| Switch push rod | 0611 | Steering | 1401 |
| Rod, accelerator bellcrank link | 0312 | Truck | 1311 |
| Rod throttle, accelerator | 0312 | WICKS | |
| Seats | 1806 | Oil, distributor | 0604.1 |
| Socket plate mounting | 0609.1 | Starter | 0603 |
| Spare gas can strap buckle | 1808 | WINCH | |
| Starter | 0603 | 2001.1 | |
| Steering gear cover | 1401 | WINDING, generator field | |
| Tail light socket | 0609.1 | 0601.3 | |
| Thrust | | WINDSHIELD | |
| Crankshaft | 0102.1 | 1804 | |
| Differential pinion side gear | 1002 | WIRES, ground and power, auxiliary light | |
| Differential side gear | 1102 | 0609.2 | |
| Starter armature | 0603 | WORM, winch | |
| Transfer countershaft gear | 0802.3 | 2001.1 | |
| Transfer output shaft | 0802.7 | YOKES | |
| Transmission countershaft | 0702.5 | Engine clutch control cable | 0202 |
| Universal joint | 1006 | Flange, propeller shaft | 0900 |
| Transfer | | Front axle differential | 1002 |
| Mounting support | 0800 | Front propeller shaft to transfer | 0802.5 |
| Output shaft, rear | 0802.7 | Hand brake rod | 1201 |
| Rear axle output shaft flange | 0802.7 | Rear axle differential | 1102 |
| Transmission | | Shifting, winch clutch | 2001.5 |
| Brake shoe | 1201 | Sleeve, propeller shaft | 0900 |
| Countershaft bearing | 0702.5 | Sliding gear, power-take-off control | 2002.5 |
| Gear shift lever spring seat | 0704 | Starter | 0603 |
| Universal joint sleeve yoke dust cap split | 0900 | Valve kicker, windshield wiper motor | 2202 |
| Water pump | 0504 | ZIPPER, door | |
| | | 2201 | |



ORDNANCE AND MANUFACTURERS' PART NUMBER INDEX

This index is prepared in strict numerical sequence; that is, all letters or dashes prefixed, suffixed, or interspersed in the numbers are disregarded. For instance: WG-J2A85 is in sequence as 285, but the complete number, including the manufacturer's symbol as the prefix, is shown in the listing. All ordnance numbers appear without any symbol prefix. Ordnance standard part numbers are not included generally in this index because they refer to standard items which may appear in various groups or already have a common application in the supply system and are not necessarily peculiar within an index of this kind.

| PART NO. | SUBGROUP | PART NO. | SUBGROUP | PART NO. | SUBGROUP |
|------------|----------|-------------|----------|-------------|----------|
| SP-LW-1 | 0804 | AL-GHA38 | 0601.1 | RWM-59 | 2001.5 |
| N&J-1 | {1808 | AL-GHA39 | 0601.1 | TP-VR60 | 0105.1 |
| | }2201 | AL-IAU39 | 0604.1 | RWM-60 | 2001.1 |
| AL-VBC2 | 0602 | RWM-39 | 2001.1 | RWM-61 | 2001.1 |
| AL-IAU6 | 0604.1 | AL-GHA40 | 0601.1 | AL-EWD62 | 0602 |
| AL-AR7S | 0603 | AL-VBC40 | 0602 | AL-MCZ62 | 0603 |
| AL-IAU10 | 0604.1 | AL-GHA41 | 0601.1 | AL-IAU62 | 0604.1 |
| AL-MCS12 | 0603 | AL-MP41A | 0603 | RWM-62 | 2001.1 |
| AL-IAH13 | 0604.1 | AL-IAU41 | 0604.1 | AL-MCS63 | 0603 |
| AL-GHA15 | 0601.1 | AL-GHA42 | 0601.1 | AL-IAU63 | 0604.1 |
| AL-VRA15 | 0602 | AL-VBC42 | 0602 | RWM-63 | 2001.1 |
| AL-IGE15 | 0604.1 | AL-IAU42 | 0604.1 | AL-MCZ64 | 0603 |
| AL-IAH15 | 0604.1 | AL-VBC43 | 0602 | RWM-64 | 2001.1 |
| AL-VRA16 | 0602 | AL-GHA46 | 0601.1 | AL-GHA65 | 0601.1 |
| AL-VRA17 | 0602 | AL-VRA46 | 0602 | RWM-65 | 2001.5 |
| AL-VBC18 | 0602 | AL-VBC46 | 0602 | AL-MCZ66 | 0603 |
| AL-MN18A | 0603 | AL-MCS46A | 0603 | RWM-66 | 2001.5 |
| AL-VBC19 | 0602 | AL-GHA47 | 0601.1 | AL-MCS67 | 0603 |
| AL-MZ19A | 0603 | AL-VBC47 | 0602 | RWM-67 | 2001.1 |
| AL-IGS19S | 0604.1 | AL-MCS47A | 0603 | WG-R6A7 1/2 | 0802.5 |
| AL-IAU20 | 0604.1 | AL-MN47B | 0603 | RWM-68 | 2001.1 |
| AL-VBC21 | 0602 | DGM-DG48 | 0501 | AL-MCZ69 | 0603 |
| WG-J2A1 | 0801 | AL-MCZ49 | 0603 | AL-MCS69 | 0603 |
| AL-VBC22 | 0602 | AL-IAU49 | 0604.1 | AL-IJT69 | 0604.1 |
| AL-VBC23 | 0602 | RWM-51 | 2001.1 | RWM-69 | 2001.1 |
| WG-J2A3 | 0802.5 | AL-IAU52 | 0604.1 | ACK-CN70S | 0302.1 |
| AL-IAU24 | 0604.1 | RWM-52 | 2001.1 | AL-MCZ70 | 0603 |
| WG-J2A4 | 0802.7 | AL-GHA53 | 0601.1 | RWM-70 | 2001.1 |
| WG-AJ2A4 | 0802.7 | RWM-53 | 2001.1 | AL-MCZ71 | 0603 |
| AL-VBC25 | 0602 | AL-MU54 | 0603 | AL-MCZ73 | 0603 |
| AL-IGB26 | 0604.1 | AL-MU54B | 0603 | RWM-73A | 2001.1 |
| WG-J2A7B | 0802.7 | AL-MU54L | 0603 | SP-S74 | {1002 |
| WG-AJ2A7B | 0802.7 | AL-IAU54 | 0604.1 | | }1102 |
| AL-IGH28 | 0604.1 | RWM-54 | 2001.5 | RWM-74A | 2001.3 |
| WG-J2A8 | 0802.7 | AL-IAT55 | 0604.1 | SP-S75 | {1002 |
| AL-IAU29 | 0604.1 | RWM-55 | 2001.1 | | }1102 |
| STN-CCX030 | 0306 | RWM-56 | 2001.1 | RWM-75 | 2001.3 |
| AL-VBC30 | 0602 | AL-MCS57 | 0603 | RWM-76 | 2001.3 |
| AL-VBC31 | 0602 | RWM-57 | 2001.1 | AL-MCZ77 | 0603 |
| RWM-33 | 2001.5 | TP-FR-RA58A | 0105.1 | RWM-77 | 2001.3 |
| WG-ASI-A34 | 1201 | SP-S58 | {1002 | AL-MCS78 | 0603 |
| AL-GHA35 | 0601.1 | | }1102 | HLH-78 | 1503 |
| AL-GAA35A | 0602 | RWM-58 | 2001.5 | RWM-79 | 2001.3 |
| AL-GHA36 | 0601.1 | SP-S59 | {1002 | RWM-80 | 2001.3 |
| AL-GHA37 | 0601.1 | | }1102 | RWM-81 | 2001.1 |

ORDNANCE AND MANUFACTURERS' PART NUMBER INDEX—Continued

| PART NO. | SUBGROUP | PART NO. | SUBGROUP | PART NO. | SUBGROUP |
|-------------|----------|--------------|----------|--------------|----------|
| RWM-82 | 2001.1 | RWM-137 | 2002.1 | WG-J2-36 | 0802.3 |
| ANB-8X3 | 0304.5 | RWM-138 | 2002.1 | SEPC-WAJ239 | 0104.1 |
| RWM-83 | 2001.1 | RWM-140 | 2002.1 | SEPC-WAJ239C | 0104.1 |
| AL-VRA84 | 0602 | RWM-141 | 2002.1 | SEPC-WAJ239D | 0104.1 |
| RWM-87 | 2001.3 | RWM-142 | 2002.1 | SEPC-WAJ239E | 0104.1 |
| RWM-88 | {2001.3 | RWM-143 | 2001.1 | WG-J2-42 | 0804 |
| | {2002.1 | SP-145W | {0802.5 | SEPC-WAJ247 | 0104.1 |
| RWM-89 | 2001.1 | | {0802.7 | SEPC-WAJ247C | 0104.1 |
| AL-IG90 | 0604.1 | WO-A147 | 0800 | SEPC-WAJ247D | 0104.1 |
| ACD-91 | 1503 | RWM-148 | 2001.3 | SEPC-WAJ247E | 0104.1 |
| RWM-95-A | 2001.3 | ACK-DK149 | 0309 | WG-J2A48A | 0801 |
| RWM-95 | 2001.3 | RWM-151 | 2001.3 | WG-J2-50½ | 0802.5 |
| RWM-96 | 2002.1 | RWM-152 | 2001.5 | WG-J2-57 | 0801 |
| AL-GT97 | 0604.1 | FDP-NDD153 | 0505 | AL-CB258 | 0609.1 |
| RWM-97 | 2002.1 | RWM-153 | 2001.1 | WG-J2-59 | 0802.7 |
| RWM-98 | 2001.1 | SP-S161 | 1104.1 | WG-J2-59A | 0802.7 |
| AL-IGS99 | 0604.1 | HC-DL-16-4 | 0609.2 | WG-J2-59B | 0802.7 |
| RWM-99 | 2001.1 | HC-DL-16-5 | 0609.2 | WG-J2-60 | 0802.5 |
| STN-CHX100 | 0306 | RWM-166B | 2001.1 | PEE-261 | 1800 |
| AL-VRP100C | 0602 | RWM-167B | 2001.3 | ANB-2X62 | 0304.5 |
| AL-VRP100K | 0602 | RWM-168B | 2001.3 | WG-J2A80A | 0804 |
| RWM-100 | 2001.1 | RWM-169B | 2001.3 | WG-J2A81A | 0804 |
| RWM-105A | 2002.1 | RWM-170B | 2002.1 | WG-J2A82 | 0804 |
| RWM-SK108 | 2001.3 | SP-S171 | 1102 | ABF-283 | 0202 |
| RWM-SK109 | 2001.3 | WO-A174 | 0202 | WG-J2-83 | 0804 |
| AL-MAD110 | 0603 | WO-A175 | 0202 | AL-IGB284 | 0604.1 |
| SPEC-OA111 | 0612 | AL-IGC175 | 0604.1 | AL-IGB284S | 0604.1 |
| SP-S112 | {1002 | WO-A176 | 0202 | WG-J2A85 | 0804 |
| | {1102 | AL-VAD176 | 0602 | WG-J286 | 0804 |
| SP-S113 | {1002 | WO-A177 | 0202 | ABF-287 | 0202 |
| | {1102 | WO-A178 | 0202 | WG-AJ2-87 | 0801 |
| SP-S114 | {1002 | WO-A179 | 0202 | SEPC-WAJ291 | 0104.1 |
| | {1102 | WO-A180 | 0202 | SEPC-WAJ292 | 0104.1 |
| AL-VAD116A | 0602 | WO-A181 | 0202 | EAT-K292 | 0105.1 |
| RWM-116 | 2002.1 | WO-A185 | 1501 | AL-MZ292 | 0603 |
| AL-VAD117A | 0602 | STN-CHX200 | 0306 | SEPC-WAJ293 | 0104.1 |
| RWM-117 | 2002.1 | WG-J2A10A | 0802.3 | SEPC-WAJ294 | 0104.1 |
| RWM-118 | 2002.5 | SEPC-WAJ211 | 0104.1 | SEPC-WAJ295 | 0104.1 |
| RWM-119 | 2002.1 | SEPC-WAJ211C | 0104.1 | SEPC-WAJ295B | 0104.1 |
| RWM-120 | 2002.5 | SEPC-WAJ211D | 0104.1 | SEPC-WAJ295D | 0104.1 |
| RWM-121 | 2002.5 | SEPC-WAJ211E | 0104.1 | SEPC-WAJ296 | 0104.1 |
| WG-1AJ2A-1½ | 0801 | WG-J2A11 | 0802.1 | SEPC-WAJ297 | 0104.1 |
| HC-DL-12-2 | 0609.2 | WG-J2A12 | 0802.7 | SEPC-WAJ297C | 0104.1 |
| RWM-122 | 2002.5 | WG-J2-15 | 0802.5 | SEPC-WAJ297D | 0104.1 |
| HC-DL-12-3 | 0609.2 | WG-AJ2-16 | 0802.5 | SEPC-WAJ297E | 0104.1 |
| RWM-123 | 2002.5 | WG-J2-16 | 0802.7 | SEPC-WAJ298 | 0104.1 |
| RWM-124 | 2002.5 | WG-J2-17 | 0802.5 | SEPC-WAJ298C | 0104.1 |
| RWM-125 | 2002.5 | WG-J2-20 | 0804 | SEPC-WAJ298D | 0104.1 |
| RWM-126 | 2002.5 | AL-GAR211A | 0601.1 | SEPC-WAJ298E | 0104.1 |
| RWM-127 | 2002.5 | WG-J2-21 | 0804 | SEPC-WAJ304 | 0104.1 |
| RWM-128 | 2002.5 | WG-J2-23 | 0804 | MRC-307S | 0702.3 |
| RWM-129 | 2002.5 | WG-J2-24 | 0804 | ANB-3X11 | 0304.5 |
| RWM-130 | 2002.5 | WG-J2B30 | 0802.3 | AL-IG313 | 0604.1 |
| AL-IGB132 | 0604.1 | WG-J2-30 | 0802.7 | TP-SV332A | 1401 |
| RWM-132 | 2002.1 | WG-J2-32 | 0802.5 | RZ-OR33-6 | 1006 |
| RWM-133 | 2002.1 | WG-J233 | 0802.5 | TD-RV344 | 1201 |
| RWM-134 | 2002.1 | WG-J2-33 | 0802.7 | WG-AS3T90C | 0700 |
| RWM-135 | 2002.1 | WG-J2A35 | 0802.3 | WO-A405 | 0202 |
| | | | | WIL-P407A | 0105.2 |

ORDNANCE AND MANUFACTURERS' PART NUMBER INDEX—Continued

| PART NO. | SUBGROUP | PART NO. | SUBGROUP | PART NO. | SUBGROUP |
|------------|----------|------------|----------|------------|----------|
| WG-4J2A4 | 0802.7 | HLH-T60-0 | 1503 | WO-A795 | 1002 |
| SP-471SP | 0804 | HLH-T60-A0 | 1503 | WO-A797 | 1002 |
| WO-A490 | 0900 | LO-FC602 | {0603 | WO-A798 | 1002 |
| WO-A495 | 1206 | | }1204.1 | WO-A814 | 1004 |
| WO-A498 | {0202 | LO-FC603 | 1204.1 | WO-A820 | 1004 |
| | }1206 | HLH-T62-0L | 1503 | WO-A821 | 1004 |
| SW-502F | 0607 | HLH-T62-0R | 1503 | WO-A824 | 1004 |
| SW-502-Z | 0607 | HLH-T62-0 | 1503 | WO-A825 | 1004 |
| SW-502V | 0607 | WO-A622 | 1401 | WO-A828 | 1004 |
| EAT-SL503 | 0105.2 | WO-A623 | 1401 | WO-A829 | 1004 |
| SW-503A | 2208.1 | EAT-K630 | 0105.1 | WO-A831 | 1004 |
| SW-504A | 0607 | HLH-T63-0 | 1503 | WO-A832 | 1004 |
| SW-504E | 0607 | WO-A635 | 1401 | WO-A833 | 1004 |
| SW-505C | 0607 | WO-A636 | 1401 | WG-T8B42 | 0704 |
| SW-505B | 0607 | SP-S638 | {1002 | WO-A844 | 1401 |
| SW-505A | 0607 | | }1102 | WO-A852 | 1004 |
| SW-505K | 0607 | HLH-T64-0 | 1503 | SP-854D | 0804 |
| SW-505N | 0607 | ABF-657 | 0201 | SEPC-863 | 0104.1 |
| SW-505L | 0607 | APB-657 | 0201 | WO-A865 | 1311 |
| SW-505P | 0607 | ABF-659 | 0202 | WO-A866 | 1311 |
| SW-505J | 0607 | HLH-T67-0 | 1503 | WO-A867 | 1311 |
| SW-506B | 0610 | AL-IG676 | 0604.1 | WO-A868 | 1006 |
| RWM-503 | 2001.1 | AL-IG680 | 0604.1 | WO-A870 | 1105.5 |
| MDR-507 | 0106.1 | PR-68-4 | 0104.1 | SP-872W | 2002.1 |
| SW-507N | 0610 | ABF-688 | 0202 | WO-A877 | 1202 |
| SW-507F | 0610 | EAT-R697 | 0105.1 | SP-884W | 0802.3 |
| RWM-511 | 2001.1 | AL-XA699 | 0602 | WO-A887 | 0202 |
| RWM-512 | 2001.1 | AL-XA699A | 0602 | WG-T90C1 | 0701 |
| WO-A513 | {1601.1 | BX-70-S-6 | 1202 | WG-T90A2 | 0702.3 |
| | }1601.3 | SP-710W | 0802.7 | WG-AT90A2 | 0702.3 |
| RWM-513 | 2001.1 | SP-712W | 0802.5 | WG-AC90C2C | 0704 |
| WO-A514 | {1601.1 | SP-715W | {0802.5 | WG-T90A2-½ | 0702.3 |
| | }1601.3 | | }0802.7 | WG-T90A3 | 0702.5 |
| RWM-514 | 2001.1 | AL-XA744H | 0601.1 | WG-T90A6 | 0702.1 |
| RWM-515 | {2001.1 | AL-XA744F | 0601.1 | WG-T90A6-½ | 0702.1 |
| | }2002.1 | AL-XA744N | 0602 | WG-T90A7B | 0702.3 |
| RWM-516 | 2001.1 | AL-XA744M | 0603 | WG-T90A8 | 0702.5 |
| RWM-517 | 2001.1 | AL-XA744C | 0603 | SP-920D | 2002.5 |
| RWM-519 | 2001.1 | AL-XA744S | 0603 | WO-A934 | 0801 |
| WO-A520 | 0802.1 | SP-745-D | 0804 | WO-A943 | 0900 |
| RWM-520 | 2001.1 | WO-A760 | 1006 | WO-A945 | 0900 |
| SEPC-535 | 0104.1 | CU-F761 | 0106.2 | CAR-YS950S | 0301 |
| SEPC-535X | 0104.1 | CU-F762 | 0106.2 | ANB-SK950 | 0304.5 |
| SEPC-535G | 0104.1 | WO-A764 | 1002 | WG-T9-50P | 0802.1 |
| SEPC-535D | 0104.1 | AL-XA766 | 0602 | WO-A954 | 0801 |
| SEPC-535XC | 0104.1 | AL-XA767 | {0601.1 | WO-A957 | 0802.5 |
| SEPC-535E | 0104.1 | | }0602 | SP-S957 | 1004 |
| SEPC-535XB | 0104.1 | AL-XA767A | 0602 | WO-A958 | 0802.7 |
| SEPC-535XD | 0104.1 | AL-XA770 | 0602 | WO-A959 | 0804 |
| WO-A544 | 1501 | AL-XA776 | 0601.1 | WO-A960 | 0804 |
| WO-A545 | 1501 | AL-XA777 | 0601.1 | WO-A962 | 0804 |
| WO-A546 | 1501 | SP-S780 | 1001 | WO-A963 | 0804 |
| RWM-556 | 2001.1 | AL-XA782 | 0602 | WO-A964 | 0804 |
| WO-A557 | 1204.1 | WO-A782 | 1001 | WO-A965 | 0804 |
| RWM-557 | 2001.1 | AL-XA783 | 0602 | WO-A966 | 0804 |
| RWM-558 | 2001.1 | AL-XA790 | 0604.1 | WO-A967 | 0804 |
| CAR-O-570S | 0301 | WO-A792 | 1002 | ANB-SK971 | {0106.5 |
| RWM-577 | 2001.1 | WO-A793 | 1002 | | }0304.5 |

ORDNANCE AND MANUFACTURERS' PART NUMBER INDEX—Continued

| PART NO. | SUBGROUP | PART NO. | SUBGROUP | PART NO. | SUBGROUP |
|-------------|----------|-------------|----------|--------------|----------|
| WO-A971 | {0804 | AL-VBC1080 | 0602 | SP-S1622 | 1006 |
| | }2002.5 | AL-MCS1083 | 0603 | SP-S1640 | 1004 |
| SP-972W | 0800 | WO-A1097 | 1601.1 | WO-A1653 | 0604.1 |
| WO-A974 | 0804 | WO-A1098 | 0615 | WO-A1663 | 0604.1 |
| WO-A976 | 0802.5 | AL-IAU1100L | 0604.1 | WO-A1671 | 0604.1 |
| WO-A978 | 0802.5 | SP-S1103 | 2002.1 | WO-A1672 | 0604.1 |
| WO-A979 | {0802.5 | WO-A1106 | 0802.5 | WO-A1684 | 0604.1 |
| | }0802.7 | CA-SX1110 | 1401 | WO-A1687 | 0604.1 |
| WO-A982 | 0802.7 | WO-A1111 | 0802.5 | WO-A1719 | 1006 |
| WO-A983 | 0802.7 | CAR-11B-12 | 0301 | WO-A1721 | 1006 |
| WO-A984 | 0802.7 | AL-VAD1118 | 0602 | WO-A1724 | 1006 |
| WO-A985 | 0802.7 | WO-A1124 | 0102.1 | WO-A1726 | 1006 |
| WO-A987 | 0802.7 | WO-A1134 | {0802.5 | WO-A1727 | 1006 |
| WO-A990 | 0802.7 | | }0802.7 | WO-A1729 | 1006 |
| WO-A991 | 0802.5 | TRI-F1140 | 2202 | WO-A1737 | 1204.3 |
| AL-SP992 | 0601.1 | CAR-11B-41 | 0301 | CAR-17-49 | 0301 |
| AL-SP-992 | 0601.3 | AL-IGC1149 | 0604.1 | MNC-R1787D | 0104.1 |
| WO-A992 | 0802.5 | BT-1150 | 1201 | MNC-R1788C | 0104.1 |
| WO-A996 | 0802.7 | WO-A1150 | 1501 | SP-18-5-7 | 0802.3 |
| WO-A997 | 1201 | CAR-11B-79 | 0301 | TRI-1895 | 2202 |
| WO-A1001 | 0802.3 | WO-A1216 | 0501 | CAR-1-897 | 0301 |
| TL-IAU1002L | 0604.1 | EAT-1237 | 0306 | CAR-1-899S | 0301 |
| AL-GHA1004 | 0601.1 | SL-1238 | 1401 | TRI-1900 | 2202 |
| AL-GHA1004S | 0601.1 | WO-A1252 | {1601.1 | WG-1AT90A2-½ | 0702.3 |
| AL-IAU1004 | 0604.1 | | }1601.3 | AD-1911B | 1401 |
| BA-ZL1005 | 0612 | WO-A1277 | 1401 | STN-AAB1917 | 0306 |
| BA-ZL1006 | 0612 | AL-MCS1278 | 0603 | AL-19X63 | 0603 |
| AL-GHA1012 | 0601.1 | AL-PS1310 | 0603 | VG-2003 | 0103 |
| AL-VBC1016 | 0602 | WO-A1357 | 0202 | RBR-200-D3 | 0609.2 |
| BA-ZF1017 | 0612 | WO-A1378 | 1204.5 | AL-IAU2004 | 0604.1 |
| WO-A1028 | {0802.5 | AL-X1379 | 0603 | AL-GHA2006FT | 0601.1 |
| | }0802.7 | WO-A1379 | 0704 | AL-MCZ2006F | 0603 |
| AL-VBC1029 | 0602 | WO-A1382 | 0704 | MID-F2011 | 1501 |
| AL-MCS1034S | 0603 | WO-A1410 | 0802.1 | AL-GHA2012S | 0601.1 |
| AL-VBC1036A | 0602 | WO-A1427 | 0900 | AL-MCS2012S | 0603 |
| AL-VBC1040S | 0602 | WO-A1441 | 0103 | RBR-201-D3 | 0609.2 |
| AL-GHA1044 | 0601.1 | PEE-144.4 | 1800 | CAR-20-22 | 0301 |
| AL-VBC1044 | 0602 | WO-A1445 | 1002 | RBR-202-D3 | 0609.2 |
| AL-IAU1048 | 0604.1 | WO-A1446 | {1002 | RBR-203-D3 | 0609.2 |
| AL-GHA1052 | 0601.1 | | }1102 | CAR-20-35 | 0301 |
| AL-GHA1053 | 0601.1 | UTS-A1453 | 0304.1 | RBR-204-D4 | 0609.2 |
| AL-VBC1055 | 0602 | WO-A1468 | {0601.1 | AL-MCZ2050 | 0603 |
| SP-S1056 | 1102 | | }0601.3 | AL-GHA2051S | 0601.1 |
| VG-1057 | 0101 | WO-A1488 | 1204.5 | AL-GHA2052 | 0601.1 |
| PR-B1060C | 0104.1 | LO-FC1499 | 1204.3 | CAR-20-61 | 0301 |
| AL-VRA1060A | 0602 | WO-A1504 | 0804 | AL-MCZ2073 | 0603 |
| AL-MCZ1060 | 0603 | WO-A1509 | 0801 | AL-IAU2076L | 0604.1 |
| AL-MCS1060 | 0603 | WO-A1511 | 0802.7 | AL-MCS2079S | 0603 |
| PR-B1061C | 0104.1 | CAR-15-43 | 0301 | RBR-209-D3 | 0609.2 |
| AL-VBC1061 | 0602 | CAR-15-44S | 0301 | RBR-210-D4 | 0609.2 |
| PR-B1062C | 0104.1 | | {0702.1 | LO-FD2108-H | 1204.1 |
| TL-MCZ1065 | 0603 | WG-X1552 | }0702.5 | | |
| AL-IAU1065 | 0604.1 | | }0704 | | {1701 |
| AL-IAU1066 | 0604.1 | | }0612 | | {1703 |
| AL-MCZ1069 | 0603 | ONB-SN1610 | 1701 | ONB-SN2113 | 1804 |
| AL-MCZ1072 | 0603 | | 1703 | | 1805 |
| AL-MCZ1073 | 0603 | | 1804 | | 1808 |
| AL-MCZ1075 | 0603 | | 1805 | | 2101 |
| | | | 1808 | CAR-2-134 | 0301 |

ORDNANCE AND MANUFACTURERS' PART NUMBER INDEX—Continued

| PART NO. | SUBGROUP | PART NO. | SUBGROUP | PART NO. | SUBGROUP |
|--------------|-----------------------|---------------|-----------------|----------------|-------------------|
| WG-J2-155 | 0804 | WO-A3098 | 1701 | RBR-430-D3 | 0609.2 |
| AL-IGC2168L | 0604.1 | AL-X3099 | 0601.1 | RBR-432-D3 | 0609.2 |
| SP-2-1-68X | 0802.7 | ACK-PD3100 | 0103 | WG-4372D | 1201 |
| WG-J2-169 | 0802.7 | SP-31P10 | 2002.5 | UCI-C4394 | 0607 |
| CAR-21-95S | 0301 | LO-FE3111 | 1204.1 | WO-A4413 | 1801 |
| AL-2235 | {0607 2208.1 | PR-031E12A | 0104.1 | WO-A4414 | 1801 |
| EAT-IE2249 | 0501 | WO-A3150 | 0106.2 | WO-A4416 | 1801 |
| ABF-2322 | 0202 | AL-MCL3161A | 0603 | EAT-ER4425J | 0106.1 |
| EAT-IE2387 | 0306 | ZP-R32-63 | 0309 | ABF-4494 | 0202 |
| EAT-ER2413 | 0106.1 | ONB-SN3318 | 1804 | ABF-4495 | 0201 |
| CAR-24-26 | 0301 | WG-AA34-12 | 1201 | WG-4496K | 0704 |
| SP-2-4-88X | 0802.5 | WG-AA34-12A | 1201 | WG-4497 | 0704 |
| PR-B2531A | 0104.1 | WG-A34-15 | 1201 | WG-4498B | 0704 |
| PR-B2532A | 0104.1 | WG-A34-18 | 1201 | WG-4559E | 0702.1 |
| PR-B2533A | 0104.1 | LO-FE3441C | 1204.1 | WG-4559A | 0702.1 |
| PR-B2534A | 0104.1 | WG-A34-63 | 1201 | WG-4559B | 0702.1 |
| MAR-2539 | 0401 | WG-A34-63A | 1201 | WG-4559C | 0702.1 |
| RZ-VA2558 | 1006 | LO-FC3474 | 1204.1 | WG-4559D | 0702.1 |
| WO-A2602 | {1804 1808 2201 | WO-A3549 | 1701 | WG-4572D | 0704 |
| EAT-CR2616 | 0306 | LO-FC3587 | 1204.1 | WG-4583 | 0704 |
| TRI-2617 | 2202 | EAT-ER3675 | 0106.1 | EAT-ER4642J | 0106.1 |
| TRI-2620 | 2202 | CAR-3-773S | 0301 | WG-4646A | 0701 |
| RBR-263-D4 | 0609.2 | ONB-SK3851C | 1808 | WG-4648 | 0704 |
| RBR-264-D4 | 0609.2 | B&B-3874 | 0201 | WG-4653 | 0702.3 |
| RBR-265-D4 | 0609.2 | CAR-39-10 | 0301 | WG-4682J | 0702.3 |
| RBR-266-D4 | 0609.2 | CAR-39-11 | 0301 | WO-A4690 | 0612 |
| LO-FE2693 | 1204.1 | SP-39Q20 | 0804 | WG-4714C | 0802.5 |
| SN-2716 | 1701 | AL-MCZ4001UT | 0603 | WG-A4714 | 0802.5 |
| ONB-SN2716 | 1703 | AL-HX-4001UT | 0611 | CAR-47-23 | 0301 |
| SP-2-7-29 | 0900 | AL-VBC4002UT | 0602 | SP-475-2 | 0802.7 |
| RBR-273-D4 | 0609.2 | AL-CT4002 | {0604.1 0605 | AL-GHA4802BUT | 0601.1 |
| RBR-274-D4 | 0609.2 | AL-IAU4006AUT | 0604.1 | AL-GHA4802UT | 0601.1 |
| RBR-276-D4 | 0609.2 | DM-4013 | 0613.1 | WG-4802 | 1201 |
| AL-RX2781 | 0604.1 | RBR-404-D4 | 0609.2 | RC-481N1 | 0607 |
| TIM-02820 | 1002 | RBR-405-D3 | 0609.2 | WO-A5105 | 0106.5 |
| ABF-2825 | 0202 | RBR-406-D4 | 0609.2 | CAR-51-21 | 0301 |
| TIM-02872 | 1002 | PR-X4071A | 0104.1 | CA-S5144 | 1401 |
| WO-A2891 | 1701 | PR-X4072A | 0104.1 | CA-S5145 | 1401 |
| LO-FC2922E | 1204.1 | PR-X4073A | 0104.1 | MNC-R5153B-STD | 0104.1 |
| LO-FC2927 | 1204.1 | RBR-410-D4 | 0609.2 | MNC-R5153B | 0104.1 |
| SMA-FLA2941 | 1501 | RBR-411-D4 | 0609.2 | MNC-R5153D | 0104.1 |
| RBR-294-D4 | 0609.2 | TRU-SA4126 | 0202 | DGM-5201 | 0105.1 |
| AL-VBC3008 | 0602 | WO-A4127 | 1808 | DAY-S5203 | 0505 |
| CAR-30-14 | 0301 | WO-A4128 | 1808 | FR-5241 | 0106.2 |
| CAR-30-20 | 0301 | RBR-415-D4 | 0609.2 | EAT-5256 | 0105.1 |
| LO-FC3024B | 1204.3 | LO-FC4158 | 1204.3 | DM-E534-1 | 0607 |
| AL-IGP3028FS | 0604.1 | RBR-417-D4 | 0609.2 | EAT-ER5362 | 0106.1 |
| AL-IGP3028 | 0604.1 | RBR-418-D4 | 0609.2 | WO-A5449 | {0304.5 0613.1 |
| CAR-30A-37 | 0301 | RBR-419-D4 | 0609.2 | WO-A5450 | 0613.1 |
| AL-X3050 | 0602 | RBR-421-D4 | 0609.2 | CDH-BW5-625 | 0504 |
| AL-X3051 | 0602 | RBR-422-D4 | 0609.2 | WO-A5630 | 0304.1 |
| AL-X3055 | 0602 | ABF-4234 | 0202 | WO-A5631 | 0304.1 |
| AL-VBC3070 | 0602 | RBR-424-D4 | 0609.2 | LO-FC5727 | 1204.1 |
| AL-VBC3071 | 0602 | RBR-425-D4 | 0609.2 | PEE-577-2 | 1804 |
| AL-IAU3076L | 0604.1 | RBR-426-D4 | 0609.2 | PEE-577.2 | 1805 |
| | | RBR-427-D4 | 0609.2 | LO-FC5778 | 1204.5 |
| | | RBR-428-D4 | 0609.2 | MNC-R5792 | 0104.1 |

ORDNANCE AND MANUFACTURERS' PART NUMBER INDEX—Continued

| PART NO. | SUBGROUP | PART NO. | SUBGROUP | PART NO. | SUBGROUP |
|-------------|----------|--------------|----------|-------------|----------|
| LO-FC5889 | 1204.3 | WO-A6796 | 0104.1 | WG-T90A48A | 0702.5 |
| SP-5951X | 0801 | WO-A6797 | 0104.1 | WO-A9052 | 0602 |
| SP-5962X | 0802.5 | WO-A6798 | 0102.2 | WG-T90A54A | 0702.1 |
| LO-FC5999A | 1204.3 | CAR-6-802 | 0301 | WG-T90-86 | 0704 |
| LO-FC6003 | 1204.3 | CAR-6-804S | 0301 | WO-A9094 | 0612 |
| LO-FC6010 | 1204.1 | WO-A6895 | 0304.5 | DP-GG9096 | 0610 |
| WO-A6112 | 1204.3 | WO-A6919 | 0106.5 | WIL-MT9281 | 0105.2 |
| WO-A6114 | 1204.3 | WIL-ER7154 | 0106.1 | WO-A9314 | 0604.1 |
| WO-A6116 | 1204.3 | CAR-7-177 | 0301 | PK-P9419R | 0612 |
| AL-CB6134 | 0609.1 | CAR-7-178S | 0301 | EAT-MT9666 | 0105.2 |
| FM-GPW6150A | 0104.1 | WIL-ER7196 | 0106.1 | SP-97Q14 | 0804 |
| FM-GPW6150C | 0104.1 | EAT-ER7200 | 0106.1 | UTS-A9894 | 0304.1 |
| FM-GPW6150D | 0104.1 | WO-A7238 | 0106.6 | UTS-A9896 | 0304.1 |
| FM-GPW6155A | 0104.1 | WO-A7239 | 0106.6 | SP-99-41 | 1104.1 |
| FM-GPW6155G | 0104.1 | FS-7332 | 0608 | AL-CB9944 | 0609.1 |
| FM-GPW6155H | 0104.1 | LO-FC7370 | 1204.1 | BT-1011-4 | 1201 |
| FM-GPW6156F | 0104.1 | LO-FD7378 | 1204.3 | BT-1011-5 | 1201 |
| FM-GPW6156H | 0104.1 | FM-GPW7523 | 0202 | BT-1011-7 | 1201 |
| B&B-6170 | 0201 | SDH-SA752-8 | 0503 | BT-1012-2 | 1201 |
| CAR-61-79 | 0301 | LO-FD7544 | 1204.3 | BT-1020-6 | 1201 |
| HLH-T62-01 | 1503 | CA-S7733 | 1401 | WO-A10231 | 1001 |
| WO-A6276 | 1006 | SP-7906X | 0801 | WO-A10269 | 0202 |
| WO-A6277 | 1006 | AL-L-7930 | 0607 | BT-1029-9A | 1201 |
| WO-A6278 | 1006 | WO-A7967 | 0401 | LO-FC10310 | 1204.3 |
| WO-A6279 | 1006 | EAT-ER8145 | 0106.1 | LO-FC10311 | 1204.3 |
| WO-A6288 | 1006 | MAT-8215 | 1601.1 | EAT-10317 | 0106.1 |
| WO-A6289 | 1006 | MAT-8216 | 1601.3 | EAT-ER10317 | 0106.1 |
| WO-A6290 | 1006 | AL-8X304 | 0607 | WO-A10469 | 0802.1 |
| WO-A6291 | 1006 | RBR-840-D4 | 0609.2 | DR-X10483 | 0603 |
| WO-A6292 | 1006 | WG-C84B12A | 0704 | CP-RC105-20 | 0605 |
| WO-A6293 | 1006 | WG-T84J50-½A | 0802.1 | BX-1067S3 | 1202 |
| WO-A6294 | 1006 | WG-T86D29 | 0702.5 | BX-1067S4 | 1202 |
| WO-A6295 | 1006 | WB-8675 | 0612 | LO-FC10945 | 1204.1 |
| EAT-ER6303 | 0106.1 | WG-T86-85 | 0702.5 | LO-FC10946 | 1204.1 |
| WO-A6305 | 1401 | LO-FC8776 | 1204.3 | LO-FC11067 | 1204.1 |
| WO-A6360 | 0202 | AC-GG8799 | 0610 | CAR-11B108 | 0301 |
| | 1206 | WG-T88-13H | 0702.3 | CAR-11B124 | 0301 |
| SP-S638-1 | 1002 | WG-T88-14F | 0702.3 | CAR-11B125S | 0301 |
| | 1102 | WG-T88-15C | 0702.3 | CAR-11B134 | 0301 |
| SP-S638-2 | 1002 | WG-T88-19E | 0702.3 | LO-FC11140 | 1204.1 |
| | 1102 | WO-A8834 | 0312 | CAR-11A142 | 0301 |
| SP-S638-3 | 1002 | WG-T90A10 | 0702.5 | CAR-11B176 | 0301 |
| | 1102 | WG-AT90A10 | 0702.5 | AL-EO11199F | 0610 |
| EB-6411G | 1804 | WG-AT90A11 | 0702.3 | CAR-112-12 | 0301 |
| WO-A6439 | 1006 | WG-T90A12 | 0702.3 | CA-H11371 | 1401 |
| SP-6510X | 2002.5 | WG-T90A16 | 0702.1 | CA-11372 | 1401 |
| FM-GPW6521 | 0105.1 | WG-AT90A16 | 0702.1 | WO-11386 | 0304.5 |
| DM-6557 | 0613.1 | WG-T90-20 | 0704 | WI-A11406X | 0103 |
| DM-6579 | 0608 | WG-T90C21 | 0704 | LO-FC11432A | 1204.1 |
| PC-EX6686 | 0612 | WG-T90-23 | 0704 | SP-11449 | 1102 |
| WO-A6701 | 0102.1 | WG-T90C24 | 0704 | LO-FC11471 | 1204.1 |
| FM-GPW6727 | 0106.6 | WG-T90A26 | 0702.3 | LO-FC11473 | 1204.1 |
| WO-A6740 | 0800 | WG-T90A28A | 0702.5 | BT-1150-1 | 1201 |
| | 1501 | WG-T90A30 | 0702.5 | BT-1150-2 | 1201 |
| WO-A6746 | 0102.2 | WG-T90A32 | 0702.5 | FR-11559 | 0106.2 |
| WO-A6747 | 0102.2 | WG-T90A33A | 0702.5 | FR-11580 | 0106.2 |
| WO-A6748 | 0102.2 | WG-T90A33 | 0702.5 | FR-11581 | 0106.2 |
| WO-A6794 | 0104.1 | WG-T90A35 | 0702.5 | FR-11582 | 0106.2 |

ORDNANCE AND MANUFACTURERS' PART NUMBER INDEX—Continued

| PART NO. | SUBGROUP | PART NO. | SUBGROUP | PART NO. | SUBGROUP |
|-------------|----------|------------|----------|------------|----------|
| FR-11583 | 0106.2 | GPC-14982 | 1401 | SP-17776 | 1105.5 |
| CAR-116-13 | 0301 | WO-A15044 | 0802.7 | UTS-A17778 | 0304.1 |
| WO-A11760 | 0612 | WO-A15045 | 0802.7 | UTS-A17779 | 0304.1 |
| WO-A11860 | 2202 | CAR-150-98 | 0301 | UTS-A17781 | 0304.1 |
| WO-A11861 | 2202 | SP-15099 | 1002 | UTS-B17785 | 0304.1 |
| WO-A11862 | 2202 | WO-A15283 | 0104.1 | UTS-B17793 | 0304.1 |
| AL-EOC11930 | 0607 | SP-15365 | 1102 | UTS-B17795 | 0304.1 |
| AL-EOC11931 | 0607 | WO-A15438 | 0106.2 | SP-17797 | 1002 |
| AL-EO-11932 | 0607 | WO-A15441 | 0106.2 | AL-CB17811 | 0609.1 |
| AL-EO-11933 | 0607 | CM-15485A | 0102.1 | AL-CB17812 | 0609.1 |
| LO-FC11940 | 1204.1 | WO-A15498 | 0401 | AL-CB17814 | 0609.1 |
| B&B-11966 | 0201 | SP-16067 | 1401 | WO-A17842 | 0304.5 |
| AL-EOF11993 | 0610 | SP-16075 | 1002 | SP-17857 | 1102 |
| STN-12085A | 0306 | CAR-163-21 | 0301 | SP-17858 | 1102 |
| AL-12X195 | 0607 | CAR-163-46 | 0301 | AL-CB17867 | 0609.1 |
| AL-12X196 | {0603 | SP-16379 | 1002 | AL-CB17891 | 0609.1 |
| | {0607 | SP-16383 | 1002 | UTS-B17915 | 0304.1 |
| AL-12X201 | 0603 | SP-16409 | 1001 | UTS-B17951 | 0304.1 |
| AL-EO12204 | 0607 | LO-FD16534 | 1204.3 | UTS-C17956 | 0304.1 |
| AL-EO12205 | 2208.1 | LO-FD16535 | 1204.3 | UTS-C17961 | 0304.1 |
| AL-EO12207 | 0607 | LO-FC16536 | 1204.3 | SP-18021X | 1104.1 |
| CAR-122-64S | 0301 | SP-16866 | 1002 | SP-18022X | 1104.1 |
| EAT-1E2322 | 0304.5 | SP-16964 | 1004 | SP-18023 | 1104.1 |
| LO-FC12411 | 1204.3 | SP-16979 | 1105.5 | SP-18024 | 1104.1 |
| LO-FC12416 | 1204.3 | SP-16991 | 1004 | SP-18027X | 1102 |
| LO-FC12496 | 1204.1 | SP-16995 | 1004 | SP-18-12-1 | 0804 |
| CU-12567 | 0106.2 | SP-17015 | 1311 | SP-18173X | 1004 |
| WO-A12863 | 2202 | SP-17016 | 1311 | SP-18174 | 1004 |
| WO-A12935 | 0304.5 | SP-17017 | 1311 | SP-18188 | 1006 |
| RG-TL13019 | 1401 | SP-17041 | 1004 | SP-18-24-1 | 0802.7 |
| LO-FC13090 | 1204.3 | SP-17048X | 1004 | MAE-18302 | 1604.1 |
| LO-FC13091 | 1204.3 | WO-A17122 | 0304.5 | MAE-18303 | 1604.1 |
| SP-13449 | {1002 | SP-17133X | 1004 | SP-18392X | 1002 |
| | {1102 | SP-17153 | 1006 | SP-18-39-3 | {0801 |
| SP-13575 | 1002 | SP-17216 | 1006 | | {1004 |
| SP-S1358-1 | 1002 | SP-17218 | 1006 | SP-18396 | 1002 |
| CAR-136-17 | 0301 | SP-17230 | 1006 | SP-18429 | 1102 |
| CAR-136-24 | 0301 | SP-17232 | 1006 | SP-18434 | 1101 |
| CAR-136-98 | 0301 | SP-17347 | 1401 | SP-18458 | 1102 |
| CAR-136-99 | 0301 | AL-CB17364 | 0609.1 | AL-CB18499 | 0609.1 |
| SP-13810 | 1102 | AL-CB17365 | 0609.1 | AL-CB18500 | 0609.1 |
| LO-FE14054B | 1204.1 | AL-CB17370 | 0609.1 | AL-CB18506 | 0609.1 |
| TIM-14131 | 0802.7 | AL-CB17371 | 0609.1 | AL-CB18509 | 0609.1 |
| TP-14T219 | 1401 | SP-17377 | 1006 | AL-CB18510 | 0609.1 |
| TP-14T220 | 1401 | AL-CB17393 | 0609.1 | SP-18528X | 1102 |
| TP-14RT224 | 1401 | AL-CB17398 | 0609.1 | SP-18529 | 1102 |
| TP-14RT225 | 1401 | AL-CB17413 | 0609.1 | SP-18530 | 1102 |
| TIM-14276 | 0802.7 | SP-17434 | 1001 | SP-18590 | 1204.5 |
| LO-FC14297 | 1204.1 | WO-A17445 | 0304.5 | SP-18592X | 1004 |
| TP-14SV331A | 1401 | SP-17483 | 1002 | SP-18593 | 1004 |
| TP-14SV333A | 1401 | AL-CB17499 | 0609.1 | SP-18594 | 1004 |
| CAR-14-359S | 0301 | SP-17509X | 1104.1 | SP-18596X | 1001 |
| LO-FC14422 | 1204.1 | SP-17555 | 1002 | SP-18602 | 1204.5 |
| CAR-145-69 | 0301 | SP-17556 | 1002 | SP-18634X | 1101 |
| CAR-145-70S | 0301 | SP-17562 | 1102 | TRI-1863-8 | 2202 |
| LO-FC14577 | 1204.1 | AL-CB17633 | 0609.1 | SP-18653 | 1104.1 |
| WG-1A4713 | 0802.7 | SP-17716 | 1102 | SP-18-66-1 | 0804 |
| CAR-148-12 | 0301 | SP-17717 | 1102 | SP-18-66-7 | 0804 |

ORDNANCE AND MANUFACTURERS' PART NUMBER INDEX—Continued

| PART NO. | SUBGROUP | PART NO. | SUBGROUP | PART NO. | SUBGROUP |
|--------------|----------|-------------|----------|---------------|----------|
| SP-18-67-2 | 0804 | BX-25829 | 1202 | KHW-33553 | 1311 |
| SP-18-67-5 | 0804 | RG-26097 | 1401 | MW-33596 | 1311 |
| SP-18-8-17 | 0802.7 | SP-2-6-118X | 0900 | MW-33596A | 1311 |
| SP-18-8-18 | 0802.7 | SP-2-6-261 | 0900 | KHW-33702 | 1311 |
| SP-18-8-19 | 0802.1 | AL-26267 | 0607 | KHW-33705 | 1311 |
| TRI-1900-1R | 2202 | AL-26269 | 0607 | KHW-33706 | 1311 |
| AL-19X119 | 0603 | TRI-2630-3 | 2202 | KHW-33707 | 1311 |
| AL-19X709 | 0603 | TRI-2631-1 | 2202 | KHW-34082 | 1311 |
| AL-CB19791 | 0609.1 | SP-2-67-11 | 0900 | KHW-34123 | 1311 |
| AL-19X888 | 0603 | AL-26809 | 0607 | MSP-344-40 | 1501 |
| SP-20017X | 1006 | USL-26819A | 0612 | MSP-344-47 | 1501 |
| SP-20047X | 1006 | RG-O26983 | 1401 | KHW-36567 | 1311 |
| SP-20068X | 1401 | RG-O28166 | 1401 | TD-3711-H8FIN | 0802.7 |
| SP-20069X | 1401 | CU-28648 | 0106.2 | BX-41545 | 1202 |
| SP-20070X | 1401 | CU-28649 | 0106.2 | AD-G47200 | 1105.5 |
| SP-20071X | 1401 | CU-28651U | 0106.2 | CAR-48-144 | 0301 |
| SP-20072X | 1401 | SP-2-86-69 | 0900 | UC-48155 | 0612 |
| SP-20075X | 1101 | CU-28717 | 0106.2 | UC-48155 | 1804 |
| SP-20124X | 1101 | CU-28751U | 0106.2 | BX-48772 | 1202 |
| CAR-203-34S | 0301 | RG-O29021 | 1401 | VG-49575 | 0102.1 |
| CAR-203-35S | 0301 | SP-2-94-29 | 0900 | VG-49650 | 0102.1 |
| WG-20366S | 0704 | SP-2-95-39 | 0900 | UC-51210 | 1806 |
| DR-X20488 | 0604.1 | SP-30020 | 1006 | WO-51575 | 0802.7 |
| AL-IAU2064S2 | 0604.1 | SP-30068 | 1401 | WO-51662 | 0312 |
| RG-O21162 | 1401 | SP-30070 | 1004 | | 0105.1 |
| HAC-21193 | 0609.1 | SP-30071 | 1004 | WO-51875 | 0702.1 |
| HAC-21208 | 0609.1 | SP-30101 | 1006 | | 0702.5 |
| HAC-21226 | 0609.1 | SP-30103 | 1006 | | 0704 |
| HAC-21325 | 0609.1 | SP-30180 | 1102 | WO-52725 | 0612 |
| SP-2-14-19 | 0900 | | 0802.5 | WO-52876 | 1002 |
| SP-2-15-13 | 0900 | SP-30185 | 0802.7 | WO-52877 | 1002 |
| SP-2-16-53 | 0900 | | 1002 | WO-52878 | 1002 |
| SP-2166-1 | 1000 | SP-30186 | 1002 | WO-52879 | 1002 |
| SP-2166-2 | 1000 | SP-30187 | 1002 | WO-52880 | 1002 |
| SP-2167-1 | 1100 | | 1102 | WO-52881 | 1002 |
| SP-2-16-93 | 0900 | SP-30188 | 1002 | WO-52883 | 0802.7 |
| HAC-21780 | 0609.1 | | 1102 | WO-52990 | 1812 |
| CAR-221-12 | 0301 | ACK-314-47 | 0306 | WO-53057 | 1808 |
| SP-2-2-459 | 0900 | BY-3105-5 | 0306 | FR-5310-2 | 0106.2 |
| SP-22-72-5 | 0804 | TIM-31520 | 1002 | WG-T54A172A | 0802.7 |
| TI-A23377 | 0605 | TIM-31593 | 1002 | DM-54963 | 0613.1 |
| BX-23969 | 1202 | BOW-BT31594 | 1002 | TI-C57993 | 0613.1 |
| SP-2-4-108X | 1002 | TIM-31594 | 1002 | 59-G-673 | 0180.4 |
| SP-2-4-581 | 1002 | RG-O32144 | 1401 | BX-60363 | 1006 |
| | 1102 | RG-O32161 | 1401 | BX-60364 | 1006 |
| TIM-24721 | 1002 | RG-O32188 | 1401 | BX-60409 | 1006 |
| TIM-24780 | 1002 | RG-O33046 | 1401 | BX-60524 | 1006 |
| BX-24784 | 1202 | RG-O33047 | 1401 | BX-60525 | 1006 |
| PR-24929 | 0104.1 | RG-O33048 | 1401 | BX-60572 | 1006 |
| RG-O25031 | 1401 | RG-O33092 | 1401 | BX-60573 | 1006 |
| TI-A25065 | 0605 | IND-33197R | 1804 | BX-60574 | 1006 |
| CAR-25-149 | 0301 | 33-T-233 | 2202 | BX-60575 | 1006 |
| CAR-25-151S | 0301 | KHW-33544 | 1311 | BX-60576 | 1006 |
| SP-2-5-266 | 0900 | KHW-33545 | 1311 | BX-60577 | 1006 |
| SP-2-5-328X | 0900 | KHW-33546 | 1311 | BX-60578 | 1006 |
| TI-A25784 | 0605 | KHW-33547 | 1311 | BX-60771 | 1006 |
| TI-A25785 | 0605 | KHW-33550 | 1311 | BX-60772 | 1006 |
| TI-A25786 | 0605 | KHW-33552 | 1311 | BX-60847 | 1006 |

ORDNANCE AND MANUFACTURERS' PART NUMBER INDEX—Continued

| PART NO. | SUBGROUP | PART NO. | SUBGROUP | PART NO. | SUBGROUP |
|-----------------------------|----------|---------------|----------|-----------|----------|
| CAR-61-207 | 0301 | CAR-101-142S | 0301 | WO-116616 | 0104.1 |
| CAR-61-356 | 0301 | CAR-101-149S | 0301 | WO-116647 | 0301 |
| CAR-61-357 | 0301 | CAR-101-160S | 0301 | WO-116651 | 0301 |
| CAR-61-426 | 0301 | BT-1012-12 | 1201 | WO-116703 | 0104.1 |
| CAR-61-460 | 0301 | CAR-101-221S | 0301 | WO-116704 | 0104.1 |
| CAR-62-183 | 0301 | BT-1020-50 | 1201 | WO-116705 | 0104.1 |
| CAR-62-183S | 0301 | FR-102153 | 0106.2 | WO-116706 | 0104.1 |
| CAR-62-184S | 0301 | WO-106740 | 0604.1 | WO-116708 | 0104.1 |
| CAR-62-185S | 0301 | WO-108874 | 0604.1 | WO-116714 | 0802.7 |
| TRI-63527 | 2202 | WO-109455 | 0603 | WO-116715 | {1601.1 |
| RG-O63983 | 1401 | TLS-B112A56-7 | 1401 | | }1601.3 |
| RG-O64003 | 1401 | WO-113373 | 0900 | WO-116716 | 1601.3 |
| RG-O64004 | 1401 | WO-113387 | 0900 | WO-116762 | 0302.1 |
| CCS-65C634 | 0105.2 | WO-113631 | 0302.1 | WO-116784 | 0301 |
| CCS-65C679 | 0105.2 | WO-115652 | 0302.1 | WO-116813 | 0301 |
| PR-72A367 | 0104.1 | WO-115796 | 0104.1 | WO-116868 | 0301 |
| TRI-75072 | 2202 | WO-115797 | 0104.1 | WO-116874 | 0301 |
| CAR-75-826S | 0301 | WO-115798 | 0104.1 | WO-116875 | 0301 |
| UC-78316 | 1804 | WO-115948 | 0105.2 | WO-116876 | 0301 |
| UC-78317 | 2201 | WO-116003 | 0104.1 | WO-116877 | 0301 |
| UC-78502 | 2201 | WO-116023 | 0104.1 | WO-116878 | 0301 |
| TRI-79513 | 2202 | WO-116024 | 0104.1 | WO-116879 | 0301 |
| TRI-809-14 | 2202 | WO-116058 | 0104.1 | WO-116880 | 0301 |
| AL-8X3029 | {0602 | WO-116060 | 0104.1 | WO-116881 | 0301 |
| | }0604.1 | WO-116061 | 0104.1 | WO-116882 | 0301 |
| AL-8X3030 | 0604.1 | WO-116108 | 0104.1 | WO-116883 | 0301 |
| WG-T86-166 | 0702.5 | WO-116109 | 0104.1 | WO-116884 | 0301 |
| TRI-8735-2 | 2202 | WO-116110 | 0104.1 | WO-116887 | 0301 |
| TRI-8741-3 | 2202 | WO-116112 | 0104.1 | WO-116888 | 0301 |
| TRI-87453 | 2202 | WO-116113 | 0104.1 | WO-116891 | 0301 |
| TRI-87555 | 2202 | WO-116116 | 0104.1 | WO-116892 | 0301 |
| TRI-8894-3 | 2202 | WO-116117 | 0104.1 | WO-116893 | 0301 |
| TRI-8896-1 | 2202 | WO-116160 | 0301 | WO-116894 | 0301 |
| WG-T90C115 | 0704 | WO-116162 | 0301 | WO-116896 | 0301 |
| WG-T90A136A | 0702.1 | WO-116163 | 0301 | WO-116897 | 0301 |
| WG-T90A137A | 0702.3 | WO-116168 | 0301 | WO-116898 | 0301 |
| WIL-ER90139 $\frac{3}{4}$ | 0106.1 | WO-116170 | 0301 | WO-116900 | 0301 |
| WG-AT90A140 | 0702.5 | WO-116175 | 0301 | WO-116901 | 0301 |
| WG-T90C148B | 0704 | WO-116177 | 0301 | WO-116902 | 0301 |
| EAT-ER90358 | 0106.1 | WO-116191 | 0301 | WO-116903 | 0301 |
| EAT-ER90359 | 0106.1 | WO-116205 | 0301 | WO-116904 | 0301 |
| EAT-ER90419 $1\frac{1}{16}$ | 0106.1 | WO-116216 | 0301 | WO-116905 | 0301 |
| AL-EX94032 | 0607 | WO-116217 | 0301 | WO-116906 | 0301 |
| WO-94096 | {1804 | WO-116329 | 0302.1 | WO-116907 | 0301 |
| | }1805 | WO-116343 | 0302.1 | WO-116908 | 0301 |
| HY-94622 | 0802.3 | WO-116344 | 0302.1 | WO-116909 | 0301 |
| RG-9470-9 | 1401 | WO-116345 | 0302.1 | WO-117017 | 0602 |
| RG-9471-9 | 1401 | WO-116346 | 0302.1 | WO-117064 | 0604.1 |
| RG-9474-4 $\frac{7}{16}$ | 1401 | WO-116347 | 0302.1 | WO-117066 | 0604.1 |
| AL-EX96034 | 0607 | WO-116384 | 0301 | WO-117090 | 0604.1 |
| AL-EX96172 | 0607 | WO-116502 | 0104.1 | WO-117091 | 0604.1 |
| ABF-100000 | 0201 | WO-116503 | 0104.1 | WO-117116 | 0609.1 |
| AL-EX100008 | 0607 | WO-116534 | 0104.2 | WO-117138 | 0302.1 |
| ABF-100021 | 0201 | WO-116535 | 0104.2 | WO-117143 | 0302.1 |
| ABF-100042 | 0201 | WO-116536 | 0104.2 | WO-117144 | 0302.1 |
| AL-EX100417 | 0607 | WO-116551 | 1202 | WO-117152 | 0302.1 |
| FR-100918 | 0106.2 | WO-116552 | 1202 | WO-117155 | 0302.1 |
| CAR-101-120 | 0301 | WO-116613 | 0104.1 | WO-117156 | 0302.1 |

ORDNANCE AND MANUFACTURERS' PART NUMBER INDEX—Continued

| PART NO. | SUBGROUP | PART NO. | SUBGROUP | PART NO. | SUBGROUP |
|-----------------|-----------------|-----------------|-----------------|-----------------|-----------------|
| WO-117157 | 0302.1 | WO-118212 | 2002.1 | WO-118290 | 0106.2 |
| WO-117160 | 0302.1 | WO-118213 | 2001.3 | WO-118291 | 0106.2 |
| WO-117337 | 0603 | WO-118214 | 2001.3 | WO-118292 | 0106.2 |
| WO-117340 | 0603 | WO-118218 | 2001.3 | WO-118293 | 0106.2 |
| WO-117432 | 0302.1 | WO-118219 | 2001.3 | WO-118351 | 0604.1 |
| WO-117858 | 0603 | WO-118220 | 2001.1 | WO-118443 | 2208.1 |
| WO-117861 | 0603 | WO-118221 | 2001.1 | WO-118444 | 2208.1 |
| WO-117892 | 0603 | WO-118222 | 2001.1 | WO-118446 | 0609.1 |
| WO-117894 | 0603 | WO-118223 | 2001.1 | WO-118447 | 0609.1 |
| WO-117904 | 0603 | WO-118224 | 2001.1 | WO-118448 | 0609.1 |
| WO-117910 | 0302.1 | WO-118229 | 2001.1 | WO-118451 | 0609.1 |
| WO-118061 | 0301 | WO-118230 | 2001.1 | WO-118453 | 0609.1 |
| WO-118099 | 0607 | WO-118231 | 2001.1 | WO-118454 | 0609.1 |
| WO-118100 | 0607 | WO-118232 | 2001.1 | WO-118456 | 0609.1 |
| WO-118101 | 2208.1 | WO-118233 | 2001.1 | WO-118459 | 0609.1 |
| WO-118102 | 0607 | WO-118235 | 2001.1 | WO-118460 | 0609.1 |
| WO-118106 | 0607 | WO-118236 | 2001.1 | WO-118461 | 0609.1 |
| WO-118107 | 0607 | WO-118237 | 2001.1 | WO-118464 | 0609.1 |
| WO-118108 | 0607 | WO-118238 | 2001.1 | WO-118465 | 0609.1 |
| WO-118109 | 0607 | WO-118239 | 2001.1 | WO-118467 | 0609.1 |
| WO-118110 | 0607 | WO-118240 | 2001.1 | WO-118468 | 0609.1 |
| WO-118112 | 0607 | WO-118241 | 2001.1 | WO-118469 | 0609.1 |
| WO-118113 | 0607 | WO-118242 | 2001.1 | WO-118470 | 0609.1 |
| WO-118115 | 0607 | WO-118243 | 2001.1 | WO-118471 | 0609.1 |
| WO-118139 | 2202 | WO-118244 | 2001.1 | WO-118472 | 0609.1 |
| WO-118140 | 2202 | WO-118245 | 2001.1 | WO-118475 | 0302.1 |
| WO-118141 | 2202 | WO-118246 | 2001.1 | WO-118476 | 0302.1 |
| WO-118142 | 2202 | WO-118247 | 2001.1 | WO-118477 | 0302.1 |
| WO-118143 | 2202 | WO-118248 | 2001.1 | WO-118478 | 0302.1 |
| WO-118146 | 2202 | WO-118249 | 2001.1 | WO-118480 | 0302.1 |
| WO-118148 | 2202 | WO-118250 | 2001.1 | WO-118481 | 0302.1 |
| WO-118149 | 2202 | WO-118251 | 2001.1 | WO-118482 | 0302.1 |
| WO-118153 | 0609.1 | WO-118252 | 2001.1 | WO-118486 | 0302.1 |
| WO-118154 | 0609.1 | WO-118253 | 2001.1 | WO-118488 | 0302.1 |
| WO-118155 | 0609.1 | WO-118254 | 2001.1 | WO-118490 | 0302.1 |
| WO-118157 | 0609.1 | WO-118255 | 2001.1 | WO-118491 | 0302.1 |
| WO-118160 | 0609.1 | WO-118256 | 2001.1 | WO-118516 | 0900 |
| WO-118163 | 0607 | WO-118257 | 2001.1 | WO-118548 | 0301 |
| WO-118165 | 0607 | WO-118258 | 2001.5 | WO-118550 | 2202 |
| WO-118166 | 0607 | WO-118259 | 2001.5 | WO-118552 | 2202 |
| WO-118167 | 0607 | WO-118260 | 2001.5 | WO-118553 | 2202 |
| WO-118168 | 0607 | WO-118261 | 2001.5 | WO-118555 | 2202 |
| WO-118181 | 2002.1 | WO-118262 | 2001.5 | WO-118556 | 2202 |
| WO-118182 | 2002.1 | WO-118263 | 2001.5 | WO-118557 | 2202 |
| WO-118183 | 2002.1 | WO-118265 | 2001.5 | WO-118558 | 2202 |
| WO-118184 | 2002.1 | WO-118266 | 2001.1 | WO-118559 | 2202 |
| WO-118198 | 2002.1 | WO-118267 | 2001.1 | WO-118560 | 2202 |
| WO-118200 | 2002.1 | WO-118272 | 2001.3 | WO-118561 | 2202 |
| WO-118201 | 2002.1 | WO-118273 | 2001.3 | WO-118566 | 2202 |
| WO-118202 | 2002.1 | WO-118274 | 2001.3 | WO-118567 | 2202 |
| WO-118203 | 2002.1 | WO-118275 | 2001.3 | WO-118568 | 2202 |
| WO-118204 | 2001.3 | WO-118276 | 2001.3 | WO-118570 | 2202 |
| WO-118205 | { 2001.1 | WO-118277 | 2001.3 | WO-118645 | 0603 |
| | { 2002.1 | WO-118280 | 2001.3 | WO-118704 | 0302.1 |
| WO-118206 | 2002.1 | WO-118281 | 2001.1 | WO-118712 | { 0604.1 |
| WO-118207 | 2002.1 | WO-118282 | 2001.1 | | { 0605 |
| WO-118211 | { 2001.3 | WO-118288 | 0106.2 | WO-118713 | 0604.1 |
| | { 2002.1 | WO-118289 | 0106.2 | WO-118714 | 0604.1 |

ORDNANCE AND MANUFACTURERS' PART NUMBER INDEX—Continued

| PART NO. | SUBGROUP | PART NO. | SUBGROUP | PART NO. | SUBGROUP |
|-----------|----------|-----------|----------|-----------|----------|
| WO-118717 | 0604.1 | WO-118820 | 0601.1 | WO-119019 | 0601.3 |
| WO-118718 | 0604.1 | WO-118821 | 0601.1 | WO-119022 | 0104.1 |
| WO-118720 | 0604.1 | WO-118822 | 0601.1 | WO-119023 | 0104.1 |
| WO-118724 | {0602 | WO-118823 | 0601.1 | WO-119024 | 0104.1 |
| | {0604.1 | WO-118824 | {0601.1 | WO-119050 | 0607 |
| WO-118725 | 0604.1 | | {0601.3 | WO-119051 | 0607 |
| WO-118729 | 0604.1 | WO-118826 | 0601.1 | WO-119053 | 0604.1 |
| WO-118730 | 0604.1 | WO-118827 | 0601.1 | WO-119054 | 0604.1 |
| WO-118731 | 0604.1 | WO-118828 | 0601.1 | WO-119055 | 0604.1 |
| WO-118732 | 0604.1 | WO-118829 | 0601.1 | WO-119058 | 0604.1 |
| WO-118733 | 0604.1 | WO-118830 | 0601.1 | WO-119084 | 0607 |
| WO-118734 | 0604.1 | WO-118831 | 0601.1 | WO-119085 | 0607 |
| WO-118735 | 0604.1 | WO-118832 | 0601.1 | WO-119086 | 0607 |
| WO-118736 | 0604.1 | WO-118833 | 0601.1 | WO-119088 | 0609.1 |
| WO-118737 | 0604.1 | WO-118834 | 0601.1 | WO-119093 | 0607 |
| WO-118738 | 0604.1 | WO-118835 | 0601.1 | WO-119116 | 0601.1 |
| WO-118752 | 0602 | WO-118879 | 0604.1 | WO-119117 | 0603 |
| WO-118753 | 0602 | WO-118885 | 0601.3 | WO-119137 | 0105.1 |
| WO-118754 | 0602 | WO-118886 | 0601.3 | WO-119138 | 0105.1 |
| WO-118755 | 0602 | WO-118887 | 0601.3 | WO-119162 | 1204.1 |
| WO-118756 | 0602 | WO-118888 | 0601.3 | WO-119212 | 2208.1 |
| WO-118757 | 0602 | WO-118889 | 0601.3 | WO-119242 | 0302.1 |
| WO-118758 | 0602 | WO-118890 | 0601.3 | WO-119248 | 0302.1 |
| WO-118759 | 0602 | WO-118891 | 0601.3 | WO-119277 | 2001.3 |
| WO-118760 | 0602 | WO-118892 | 0601.3 | WO-119287 | 1204.1 |
| WO-118761 | 0602 | WO-118893 | 0601.3 | WO-119367 | 0607 |
| WO-118762 | 0602 | WO-118894 | 0601.3 | WO-119477 | 1201 |
| WO-118763 | 0602 | WO-118896 | 0601.3 | WO-119478 | 0602 |
| WO-118764 | 0602 | WO-118897 | 0601.3 | WO-119479 | 0602 |
| WO-118765 | 0602 | WO-118899 | 0601.3 | WO-119484 | 0601.3 |
| WO-118766 | 0602 | WO-118900 | 0601.3 | WO-119485 | 0601.3 |
| WO-118768 | 0602 | WO-118904 | 0601.3 | WO-119491 | 0601.3 |
| WO-118769 | {0601.1 | WO-118905 | 0601.3 | WO-119493 | 0601.3 |
| | {0602 | WO-118906 | 0601.3 | WO-119496 | 0601.3 |
| WO-118770 | 0602 | WO-118908 | 0601.3 | WO-119510 | 0609.1 |
| WO-118771 | 0602 | WO-118909 | 0601.3 | WO-119513 | 1204.1 |
| WO-118772 | 0602 | WO-118910 | 0601.3 | WO-119544 | 0601.3 |
| WO-118774 | 0602 | WO-118911 | 0601.3 | WO-119545 | 0601.3 |
| WO-118775 | 0602 | WO-118912 | 0601.3 | WO-119546 | 0601.3 |
| WO-118776 | 0602 | WO-118914 | 0601.3 | WO-119547 | 0601.3 |
| WO-118786 | 0602 | WO-118915 | 0601.3 | WO-119596 | 0603 |
| WO-118787 | 0602 | WO-118920 | 0607 | WO-119610 | 0603 |
| WO-118788 | 0602 | WO-118921 | 0607 | WO-119611 | 0603 |
| WO-118789 | 0602 | WO-118922 | 0607 | WO-119612 | 0603 |
| WO-118791 | 0602 | WO-118923 | 0609.1 | WO-119613 | 0603 |
| WO-118793 | 0602 | WO-118924 | 0609.1 | WO-119614 | 0603 |
| WO-118794 | 0602 | WO-118925 | 0609.1 | WO-119615 | 0603 |
| WO-118795 | 0602 | WO-118926 | 0609.1 | WO-119616 | 0603 |
| WO-118796 | 0602 | WO-118927 | 0609.1 | WO-119617 | 0603 |
| WO-118800 | 0602 | WO-118939 | 0601.1 | WO-119618 | 0603 |
| WO-118803 | 0601.1 | WO-118952 | 1601.1 | WO-119619 | 0603 |
| WO-118805 | 0601.1 | WO-118958 | 0601.1 | WO-119620 | 0603 |
| WO-118806 | 0601.1 | WO-118996 | 0601.3 | WO-119621 | 0603 |
| WO-118807 | 0601.1 | WO-118997 | 0601.3 | WO-119622 | 0603 |
| WO-118812 | 0601.1 | WO-118998 | 0601.3 | WO-119623 | 0603 |
| WO-118813 | 0601.1 | WO-118999 | 0601.3 | WO-119624 | 0603 |
| WO-118818 | 0601.1 | WO-119011 | 0601.3 | WO-119625 | 0603 |
| WO-118819 | 0601.1 | WO-119016 | 0601.3 | WO-119627 | 0603 |

ORDNANCE AND MANUFACTURERS' PART NUMBER INDEX—Continued

| PART NO. | SUBGROUP | PART NO. | SUBGROUP | PART NO. | SUBGROUP |
|-----------------|-----------------|-----------------|-----------------|-----------------|-----------------|
| WO-119628 | 0603 | WO-119766 | 0603 | WO-120932 | 0302.1 |
| WO-119629 | 0603 | WO-119768 | 0603 | WO-120946 | 0302.1 |
| WO-119630 | 0603 | WO-119829 | 0603 | CAR-121-138 | 0301 |
| WO-119631 | 0603 | WO-119847 | 0302.1 | CAR-121-222 | 0301 |
| WO-119632 | 0603 | WO-119848 | 0302.1 | RG-TL122003 | 1401 |
| WO-119633 | 0603 | WO-119867 | 0302.1 | SZ-123770 | 0505 |
| WO-119634 | 0603 | WO-119913 | 1601.1 | CU-12567-2 | 0106.2 |
| WO-119635 | 0603 | WO-119914 | 1601.1 | RG-126023 | 1401 |
| WO-119636 | 0603 | WO-119933 | 1601.3 | RG-TL129000 | 1401 |
| WO-119637 | 0603 | WO-119934 | 1601.3 | ABF-130002 | 0202 |
| WO-119638 | 0603 | WO-119935 | 1601.3 | ABF-130003 | 0202 |
| WO-119639 | 0603 | WO-119944 | 1601.1 | SP-13331-3 | 1102 |
| WO-119640 | 0603 | WO-119945 | 1601.3 | SP-13338-3 | 1102 |
| WO-119641 | 0603 | WO-119953 | 0106.2 | GM-135974 | 0609.1 |
| WO-119642 | 0603 | WO-119956 | 0607 | CAR-136-166 | 0301 |
| WO-119643 | 0603 | WO-119962 | 1601.1 | CAR-150-139 | 0301 |
| WO-119646 | 0603 | WO-119963 | 1601.3 | SP-15969-3 | 1104.1 |
| WO-119647 | 0603 | WO-119982 | 0106.2 | UCI-160306 | 0607 |
| WO-119649 | 0603 | WO-119983 | 0106.2 | UCI-160338 | 0607 |
| WO-119651 | 0302.1 | WO-119985 | 0106.2 | UCI-160339 | 0607 |
| WO-119652 | 0302.1 | WO-119986 | 0106.2 | SP-16322-2 | 1002 |
| WO-119653 | 0302.1 | WO-119987 | 0106.2 | SP-16322-4 | 1002 |
| WO-119656 | 0302.1 | WO-119988 | 0604.1 | SP-16323-2 | 1002 |
| WO-119657 | 0302.1 | WO-119998 | 0602 | SP-16323-4 | 1002 |
| WO-119658 | 0302.1 | WO-119999 | 2202 | SP-16992-2 | 1004 |
| WO-119659 | 0302.1 | WO-120000 | 2202 | SP-16992-3 | 1004 |
| WO-119661 | 0302.1 | WO-120001 | 2202 | SP-16992-4 | 1004 |
| WO-119672 | 0302.1 | WO-120002 | 2202 | CAR-170-138 | 0301 |
| WO-119704 | 0900 | WO-120003 | 2202 | CAR-170-139 | 0301 |
| WO-119705 | 0900 | WO-120087 | 0304.5 | B170220 | 0302.1 |
| WO-119706 | 0900 | WO-120088 | 0304.5 | SP-17122-3 | 1006 |
| WO-119707 | 0900 | WO-120089 | 0304.5 | SP-17122-4 | 1006 |
| WO-119731 | 0900 | WO-120090 | 0304.5 | TRI-1727-28 | 2202 |
| WO-119732 | 0900 | WO-120108 | 2202 | SP-17521-2 | 1104.1 |
| WO-119733 | 0900 | WO-120109 | 2202 | SP-17521-3 | 1104.1 |
| WO-119739 | 0301 | WO-120123 | 0302.1 | SP-17521-4 | 1104.1 |
| WO-119740 | 0301 | WO-120127 | 0900 | SP-18-15-18 | 0801 |
| WO-119741 | 0301 | CAR-120-157 | 0301 | SP-18-155-2 | 0801 |
| WO-119742 | 0301 | WO-120158 | 0601.1 | SP-18172-1X | 1006 |
| WO-119743 | 0301 | WO-120179 | { 1601.1 | SP-18172-2X | 1006 |
| WO-119744 | 0301 | | } 1601.3 | SP-18-187-4 | 0802.3 |
| WO-119745 | 0301 | WO-120180 | { 1601.1 | SP-18-19-32 | 0802.5 |
| WO-119746 | 0301 | | } 1601.3 | SP-18-19-33 | 0802.7 |
| WO-119747 | 0301 | WO-120181 | { 1601.1 | SP-18-223-2 | 0802.5 |
| WO-119748 | 0301 | | } 1601.3 | SP-18-223-3 | { 0802.5 |
| WO-119749 | 0301 | WO-120182 | { 1601.1 | | } 0802.7 |
| WO-119750 | 0301 | | } 1601.3 | SP-18-228-7 | 0802.7 |
| WO-119751 | 0301 | WO-120183 | 1601.1 | SP-18-228-8 | 0802.7 |
| WO-119752 | 0900 | WO-120184 | 1601.1 | SP-18-228-9 | 0802.7 |
| WO-119757 | 0304.1 | WO-120185 | 1601.1 | SP-18-267-5 | 0801 |
| WO-119758 | 0304.1 | WO-120186 | 1601.3 | SP-18-324-2 | 0801 |
| WO-119759 | 0304.1 | WO-120187 | 1601.3 | SP-18-362-6 | 0802.7 |
| WO-119760 | 0304.1 | WO-120188 | 1601.3 | SP-18-362-7 | 0802.5 |
| WO-119761 | 0304.1 | WO-120202 | 0604.1 | SP-18-381-2 | 0802.5 |
| WO-119762 | 0304.1 | WO-120203 | 0900 | SP-18397-6X | 1002 |
| WO-119763 | 0304.1 | WO-120252 | 0603 | A184238 | 0302.1 |
| WO-119764 | 0304.1 | WO-120264 | 0302.1 | SP-18452-2 | 0802.7 |
| WO-119765 | 0304.1 | WO-120640 | 0106.2 | SP-18-454-3 | 2208.1 |

ORDNANCE AND MANUFACTURERS' PART NUMBER INDEX—Continued

| PART NO. | SUBGROUP | PART NO. | SUBGROUP | PART NO. | SUBGROUP |
|--------------|---------------|-----------------|-------------------|-------------|----------|
| SP-18-466-1 | 0802.5 | BX-303128 | 1202 | WO-375917 | 0105.5 |
| SP-18597-1X | 1006 | BX-303133 | 1202 | WO-375994 | 0105.1 |
| SP-18597-2X | 1006 | BX-303134 | 1202 | WO-376373 | 0101 |
| SP-18599-7X | 1102 | BX-303135 | 1202 | WO-381510 | 0102.2 |
| TI-U1864-20A | 0605 | BX-303136 | 1202 | WO-391404 | 1202 |
| AL-19X3168 | 0603 | BX-303138 | 1202 | RG-400023 | 1401 |
| MSP-200-145 | {1501 1504 | BX-303141 | 1204.3 | RG-400025 | 1401 |
| SP-20128-1X | 1006 | BX-303142 | 1204.3 | RG-400049 | 1401 |
| SP-20128-2X | 1006 | BX-303173 | 1202 | RG-400050 | 1401 |
| WH-210818 | 0105.2 | BX-303174 | 1202 | RG-401100 | 1401 |
| SP-2-1-1191 | 0802.7 | BX-303257 | 1202 | RG-401138 | 1401 |
| HAC-21216F1 | 0609.1 | BX-303259 | 1202 | RG-402129 | 1401 |
| A214539 | 0603 | A304039 | 1202 | RG-402141 | 0611 |
| A214739 | 0302.1 | A308282 | 0106.2 | SW-G418041 | 2208.1 |
| A214741 | 0302.1 | SP-310057X | 0802.7 | SW-418045 | 2208.1 |
| A214743 | 0302.1 | SP-310058 | 1201 | SW-418046 | 2208.1 |
| A214746 | 0302.1 | SP-310059 | 1201 | SW-G418049 | 2208.1 |
| A214750 | 0302.1 | SP-310085 | 1201 | SW-418100 | 0607 |
| A214752 | 0302.1 | SP-310134X | 0802.5 | SW-418101 | 0607 |
| A214758 | 0302.1 | A311679 | 0613.1 | SW-418102 | 0607 |
| A214759 | 0302.1 | A312057 | 0301 | SW-418104 | 0607 |
| A214761 | 0302.1 | SP-31-246-2 | 0802.3 | SW-418105 | 0607 |
| A214889 | 0302.1 | A323138 | 0302.1 | SW-418107 | 0607 |
| A214987 | 0302.1 | WO-323397 | 0612 | SW-418112 | 0607 |
| AL-2-15-3-50 | 0609.1 | A327340 | 2202 | SW-418113 | 0607 |
| AL-2-15-4-50 | 0609.1 | A327341 | 2202 | SW-419106 | 0607 |
| AL-2-15-8-49 | 0609.1 | A327342 | 2202 | SW-446125 | 2208.1 |
| A226060 | 0103 | SP-330086 | 1201 | RG-450161 | 0611 |
| SP-230007 | 0900 | SP-330087 | 1201 | AC-456409 | 0302.1 |
| SP-230008 | 0900 | SP-330088 | 1201 | RG-475104 | 1401 |
| SP-2-3-1111X | 0900 | SP-330089 | 1201 | RG-500824 | 1401 |
| SP-2-3-1131X | 0900 | SP-330090 | 1201 | RG-500931 | 1401 |
| SP-2-4-1421 | 0802.5 | SP-330091 | 1201 | RG-502282 | 1401 |
| SP-2-4-1451X | 1102 | SP-330150 | 1201 | RG-505765 | 1401 |
| B246309 | 0304.5 | SP-330151 | 1201 | IL-510210 | 0609.1 |
| SP-25Q1250 | 0804 | SP-330152 | {0802.5 0802.7 | IL-510214 | 0609.1 |
| SP-25Q1251 | 0804 | WO-330964 | 0106.1 | IL-510220 | 0609.1 |
| TRI-2618-17 | 2202 | GE-331B151 | 0605 | IL-510221 | 0609.1 |
| A281413 | 0301 | GE-331B152 | 0613.1 | CA-5-11373 | 1401 |
| A281437 | 0301 | NMP-333D160 | 1002 | IL-520312 | 0609.1 |
| A281457 | 0301 | WO-339043 | 0202 | SP-550163 | 1002 |
| MAT-2816-25 | 1601.1 | WO-339372 | {1601.1 1601.3 | SP-550179 | 1002 |
| A291788 | 0304.5 | MSP-344-289 | 1501 | SP-550213 | 1002 |
| A292984 | 0302.1 | MSP-344-290 | 1501 | SP-550224 | 1002 |
| A293029 | 0301 | MSP-344-306 | 1501 | SP-550233 | 1002 |
| A293030 | 0301 | MSP-344-324 | 1501 | SP-550246 | 1002 |
| A293034 | 0301 | A346734 | 0301 | SP-55-454-3 | 2208.1 |
| A293056 | 0301 | A346736 | 0301 | WO-605688 | 1806 |
| A293063 | 0301 | A346738 | 0301 | OKS-613306 | 0304.1 |
| WO-300143 | 0108 | WO-347002 | {0613.1 2202 | OKS-613387 | 0304.1 |
| WO-K300159 | 1806 | TD-TI-3722-V-48 | 1201 | WO-630004 | 0301 |
| SP-30067-1 | 1401 | WO-372438 | 0312 | WO-630068 | 0202 |
| SP-30067-2 | 1401 | WO-374586 | 1202 | WO-630112 | 0202 |
| SP-30102-1 | 1006 | WO-375877 | 0102.1 | WO-630117 | 0202 |
| SP-30102-2 | 1006 | | | WO-630129 | 0201 |
| BX-302691 | 1202 | | | WO-630262 | 0102.1 |
| BX-303117 | 1202 | | | WO-630285 | 0102.2 |
| | | | | WO-630288 | 0102.2 |

ORDNANCE AND MANUFACTURERS' PART NUMBER INDEX—Continued

| PART NO. | SUBGROUP | PART NO. | SUBGROUP | PART NO. | SUBGROUP |
|-----------|----------|-----------|----------|-----------|----------|
| WO-630299 | 0106.5 | WO-637583 | 1204.1 | WO-640020 | 0105.2 |
| WO-630303 | 0105.1 | WO-637590 | 1204.1 | WO-640034 | 0504 |
| WO-630305 | 0105.1 | WO-637597 | 1204.1 | WO-640038 | 1104.1 |
| WO-630365 | 0105.5 | WO-637598 | 1204.1 | WO-640112 | 0202 |
| WO-630389 | 0106.1 | WO-637604 | {0603 | WO-640123 | 0202 |
| WO-630390 | 0106.1 | | {1204.1 | WO-640193 | 0612 |
| WO-630396 | 0106.6 | WO-637605 | 1204.1 | WO-640343 | 2002.1 |
| WO-630397 | 0106.6 | WO-637606 | 1204.1 | WO-640351 | 0701 |
| WO-630398 | 0106.6 | WO-637615 | 0604.1 | WO-640389 | 0702.3 |
| WO-630518 | 0106.1 | WO-637790 | 0102.2 | WO-640390 | 0702.3 |
| WO-630593 | {0202 | WO-637905 | 1202 | WO-640391 | 0702.3 |
| | {1206 | WO-637936 | 1604.1 | WO-640392 | 0702.3 |
| WO-630753 | 1401 | WO-638156 | 0202 | WO-640393 | 0702.3 |
| WO-630754 | 1401 | WO-638157 | 0202 | WO-640394 | 0702.3 |
| WO-630755 | 1401 | WO-638159 | 0202 | WO-640395 | 0702.3 |
| WO-632156 | 0103 | WO-638513 | 0102.1 | WO-640396 | 0702.3 |
| WO-632157 | {0103 | WO-638636 | 0105.1 | WO-640397 | 0702.3 |
| | {0104.1 | WO-638737 | 0302.1 | WO-640398 | 0702.3 |
| WO-632177 | 0202 | WO-638780 | 1201 | WO-640399 | 0702.3 |
| WO-633948 | 2202 | WO-638918 | 1401 | WO-640400 | 0702.3 |
| WO-634762 | 0800 | WO-639102 | 1401 | WO-640401 | 0702.3 |
| WO-634796 | 0102.1 | WO-639103 | 1401 | WO-640405 | 0702.5 |
| WO-634813 | 0106.1 | WO-639108 | 1401 | WO-640409 | 0702.5 |
| WO-634814 | 0401 | WO-639109 | 1401 | WO-640410 | 0702.5 |
| WO-635097 | 0304.1 | WO-639110 | 1401 | WO-640411 | 0702.5 |
| WO-635377 | 0102.2 | WO-639121 | 1401 | WO-640412 | 0702.5 |
| WO-635863 | 0704 | WO-639191 | 1401 | WO-640413 | 0702.5 |
| WO-635868 | 0704 | WO-639429 | 0802.5 | WO-640417 | 0702.5 |
| WO-635886 | 0101 | WO-639578 | 0201 | WO-640418 | 0702.5 |
| WO-636148 | 0104.1 | WO-639818 | 1102 | WO-640419 | 0702.5 |
| WO-636298 | 0504 | WO-639862 | 0104.2 | WO-640420 | 0702.5 |
| WO-636344 | 1104.1 | WO-639864 | 0104.1 | WO-640422 | 0702.1 |
| WO-636360 | {1002 | WO-639949 | 1204.3 | WO-640427 | 0702.1 |
| | {1102 | WO-639959 | {1002 | WO-640428 | 0702.1 |
| WO-636372 | 1311 | | {1102 | WO-640431 | 0702.3 |
| WO-636374 | 1104.1 | WO-639960 | {1002 | WO-640578 | 0201 |
| WO-636527 | 1002 | | {1102 | WO-640617 | 2002.5 |
| WO-636553 | 1102 | WO-639961 | {1002 | WO-640618 | 2002.5 |
| WO-636565 | {1002 | | {1102 | WO-640619 | 2002.5 |
| | {1102 | WO-639962 | {1002 | WO-640622 | 2002.1 |
| WO-636566 | 1002 | | {1102 | WO-640623 | 2002.5 |
| WO-636568 | 1002 | WO-639969 | {1002 | WO-640624 | 2002.5 |
| WO-636570 | 1102 | | {1102 | WO-640625 | 2002.5 |
| WO-636577 | 1001 | WO-639970 | {1002 | WO-640626 | 2002.5 |
| WO-636863 | 1202 | | {1102 | WO-640627 | 2002.5 |
| WO-636961 | 0104.1 | WO-639971 | {1002 | WO-640628 | 2002.5 |
| WO-637042 | 0104.1 | | {1102 | WO-640629 | 2002.5 |
| WO-637053 | 0504 | WO-639972 | {1002 | WO-640630 | 2002.5 |
| WO-637234 | 1002 | | {1102 | WO-640632 | 2002.1 |
| WO-637235 | 1002 | WO-639973 | {1002 | WO-640659 | 2002.5 |
| WO-637236 | 0102.2 | | {1102 | WO-640699 | 1002 |
| WO-637426 | 1204.5 | WO-639974 | {1002 | WO-640777 | 0702.5 |
| WO-637427 | 1204.5 | | {1102 | WO-640778 | 0702.5 |
| WO-637432 | 1204.5 | WO-639975 | {1002 | WO-640779 | 0702.5 |
| WO-637539 | 1204.3 | | {1102 | WO-640782 | 0702.1 |
| WO-637545 | 1204.3 | WO-639979 | 0106.6 | WO-640783 | 0702.1 |
| WO-637578 | 1204.3 | WO-639980 | 0106.6 | WO-640784 | 0702.1 |
| WO-637579 | 1204.3 | WO-639993 | 0504 | WO-640785 | 0702.1 |

ORDNANCE AND MANUFACTURERS' PART NUMBER INDEX—Continued

| PART NO. | SUBGROUP | PART NO. | SUBGROUP | PART NO. | SUBGROUP |
|-----------|----------|-----------|----------|-----------|----------|
| WO-640786 | 0702.3 | WO-642764 | 0704 | WO-646316 | 0102.1 |
| WO-640885 | 1311 | WO-642765 | 0704 | WO-646421 | 0105.1 |
| WO-640886 | 1202 | WO-642766 | 0704 | WO-646620 | 1401 |
| WO-640888 | 1202 | WO-642767 | 0704 | WO-646812 | 0503 |
| WO-640893 | 0702.1 | WO-642768 | 0704 | WO-646942 | 1501 |
| WO-640894 | 0702.1 | WO-642769 | 0704 | WO-647008 | 1401 |
| WO-640942 | 1204.5 | WO-642770 | 0704 | WO-647026 | 1501 |
| WO-640943 | 1204.5 | WO-642943 | 1605 | WO-647061 | 1102 |
| WO-640945 | 1104.1 | WO-642944 | 1605 | WO-647062 | 1102 |
| WO-640959 | 1104.1 | WO-642987 | 1601.3 | WO-647063 | 1102 |
| WO-640965 | 1102 | WO-643334 | 0105.1 | WO-647071 | 0105.2 |
| WO-640966 | 1104.1 | WO-643621 | 0702.3 | WO-647072 | 0105.2 |
| WO-640967 | 1104.1 | WO-643671 | 1204.1 | WO-647078 | 0102.1 |
| WO-640968 | 1104.1 | WO-643834 | 0105.5 | WO-647089 | 1401 |
| WO-640969 | 1104.1 | WO-643839 | 0102.1 | WO-647098 | 1401 |
| WO-640972 | 1104.1 | WO-644122 | 0800 | WO-647099 | 1401 |
| WO-640973 | 1104.1 | WO-644141 | 1002 | WO-647282 | 1204.1 |
| WO-640974 | 1104.1 | WO-644142 | 1002 | WO-647286 | 1204.1 |
| WO-641047 | 0106.1 | WO-644148 | 1002 | WO-647289 | 1204.1 |
| WO-641049 | 0105.3 | WO-644233 | 0704 | WO-647297 | 1204.1 |
| WO-641050 | 0106.6 | WO-644316 | 0702.5 | WO-647415 | 1501 |
| WO-641096 | 0105.5 | WO-644319 | 0801 | WO-647468 | 0102.1 |
| WO-641281 | 0105.5 | WO-644366 | 0202 | WO-647492 | 1204.1 |
| WO-641282 | 0105.5 | WO-644542 | 1105.5 | WO-647574 | 1805 |
| WO-641283 | 0105.5 | WO-644551 | 0702.3 | WO-647592 | 1204.1 |
| WO-641479 | 0106.1 | WO-644552 | 0702.3 | WO-647606 | 1204.1 |
| WO-641480 | 0106.1 | WO-645071 | 1501 | WO-647634 | 1206 |
| WO-641482 | 0106.1 | WO-645072 | 1501 | WO-647635 | 1206 |
| WO-641483 | 0106.1 | WO-645093 | 0105.1 | WO-648069 | 1204.1 |
| WO-641484 | 0106.1 | WO-645160 | 0102.2 | WO-648438 | 0501 |
| WO-641695 | 0201 | WO-645161 | 0102.2 | WO-648439 | 0501 |
| WO-641742 | 0106.1 | WO-645162 | 0102.2 | WO-648452 | 0304.5 |
| WO-641768 | 0104.2 | WO-645163 | 0102.2 | WO-648591 | 0306 |
| WO-641769 | {0104.2 | WO-645164 | 0102.2 | WO-648674 | 1204.3 |
| | {0105.2 | WO-645165 | 0102.2 | WO-648766 | 0108 |
| WO-641770 | 0104.2 | WO-645166 | 0102.2 | WO-648791 | 0105.2 |
| WO-641771 | 0104.2 | WO-645167 | 0102.2 | WO-648795 | 0108 |
| WO-641772 | 0104.2 | WO-645168 | 0102.2 | WO-648798 | 0105.2 |
| WO-641773 | 0104.2 | WO-645169 | 0102.2 | WO-648803 | 0105.2 |
| WO-641774 | 0104.2 | WO-645170 | 0102.2 | WO-648807 | 0105.2 |
| WO-641775 | 0104.2 | WO-645171 | 0102.2 | WO-648852 | 0503 |
| WO-641929 | {0202 | WO-645539 | {0106.6 | WO-648865 | 0106.6 |
| | {1206 | | {1204.5 | WO-648886 | 0108 |
| WO-642013 | 1204.3 | WO-645595 | 0105.3 | WO-648927 | 0610 |
| WO-642014 | 1204.3 | WO-645628 | 0106.1 | WO-648935 | 0108 |
| WO-642052 | 1501 | WO-645629 | 0106.1 | WO-648974 | 1204.1 |
| WO-642121 | 1102 | WO-645663 | 1401 | WO-649052 | 0106.5 |
| WO-642188 | 0802.3 | WO-645702 | 1501 | WO-649219 | 1401 |
| WO-642189 | 0802.3 | WO-645789 | 1102 | WO-649240 | 1401 |
| WO-642191 | 0802.3 | WO-645790 | 1102 | WO-649454 | {1002 |
| WO-642214 | 0106.1 | WO-645905 | 0503 | | {1102 |
| WO-642233 | 0609.1 | WO-645980 | 0702.1 | WO-649666 | 0105.2 |
| WO-642520 | 0105.5 | WO-646073 | {0312 | WO-649692 | 0609.1 |
| WO-642623 | 0202 | | {2002.5 | WO-649704 | 0800 |
| WO-642624 | 0202 | WO-646147 | 0106.1 | WO-649705 | 1501 |
| WO-642754 | 0701 | WO-646232 | 0503 | WO-649707 | 0100.2 |
| WO-642758 | 0704 | WO-646238 | 1311 | WO-649708 | 0101 |
| WO-642759 | 0704 | WO-646239 | 1311 | WO-649709 | 0105.2 |

ORDNANCE AND MANUFACTURERS' PART NUMBER INDEX—Continued

| PART NO. | SUBGROUP | PART NO. | SUBGROUP | PART NO. | SUBGROUP |
|-----------|----------|-------------|----------|-----------|----------|
| WO-649720 | 0503 | WO-670540 | 1801 | WO-673580 | 1806 |
| WO-649721 | 0505 | WO-670926 | 1808 | WO-673581 | 1806 |
| WO-649722 | 0102.1 | WO-670929 | 1808 | WO-673586 | 1806 |
| WO-649726 | 0608 | WO-670953 | {1808 | WO-673587 | 1806 |
| WO-649739 | 0309 | | }2201 | WO-673593 | 1806 |
| WO-649751 | 0105.1 | WO-671829 | 1800 | | {1703 |
| WO-649769 | 1006 | WO-671960 | 1806 | WO-673597 | 1804 |
| WO-649770 | 1006 | WO-671961 | 1806 | | }2201 |
| WO-649771 | 1006 | WO-671962 | 1806 | | {0609.2 |
| WO-649772 | 1006 | WO-671963 | 1806 | WO-673600 | 1804 |
| WO-649782 | 1004 | WO-671968 | 2201 | | }1806 |
| WO-649783 | 1004 | WO-671979 | 2201 | | }1808 |
| WO-649784 | 1006 | WO-672000 | 1806 | WO-673621 | {1803.1 |
| WO-649816 | {0601.1 | WO-672012 | 1806 | | }2101 |
| | {0601.3 | WO-672016 | 1806 | WO-673622 | 2202 |
| WO-649817 | {0601.1 | WO-672592 | 1803.1 | WO-673623 | 2202 |
| | {0601.3 | WO-672616 | 1804 | WO-673631 | 1703 |
| WO-649818 | {0601.1 | WO-672846 | 1805 | WO-673708 | 1808 |
| | {0601.3 | SP-6-73-124 | 1006 | WO-673709 | 1808 |
| WO-649823 | 0105.5 | WO-673158 | 2201 | WO-673719 | 2202 |
| WO-649849 | 0102.1 | SP-6-73-218 | 1201 | WO-673771 | 2201 |
| WO-649859 | 1204.5 | WO-673325 | 1804 | WO-673774 | {1806 |
| WO-649865 | 0401 | WO-673339 | 1804 | | }2201 |
| WO-649869 | 0401 | WO-673344 | 1504 | WO-673775 | 1806 |
| WO-649873 | 1311 | WO-673349 | 1504 | WO-673777 | 2201 |
| WO-649874 | 1311 | WO-673371 | 1806 | WO-673782 | 2201 |
| WO-649875 | 1311 | WO-673387 | 1806 | WO-673791 | 2201 |
| WO-649878 | 1311 | WO-673408 | 1806 | WO-673794 | 2201 |
| WO-649936 | 1311 | WO-673415 | 0306 | WO-673797 | 2201 |
| WO-649937 | 1311 | WO-673420 | 1504 | WO-673803 | 2201 |
| WO-649938 | 1311 | WO-673436 | 1703 | WO-674004 | 2201 |
| WO-649995 | 1401 | WO-673438 | 0612 | WO-674078 | 1808 |
| WO-650482 | 0312 | | {1703 | WO-674080 | 1808 |
| WO-650483 | 0312 | WO-673456 | {1804 | WO-674081 | 1808 |
| WO-650484 | 0312 | | {1806 | WO-674086 | 1808 |
| WO-650684 | {0202 | | {1808 | WO-674176 | 2201 |
| | }1206 | WO-673457 | 1808 | WO-674230 | {1805 |
| WO-663079 | 1804 | WO-673458 | 1504 | | }1808 |
| WO-663194 | 1803.1 | WO-673468 | {1701 | WO-674232 | 1808 |
| WO-663195 | 1803.1 | | }2101 | WO-674267 | 1804 |
| WO-663336 | 1808 | WO-673472 | 1808 | WO-674316 | 1805 |
| WO-663428 | 1803.1 | WO-673474 | 1805 | | {1701 |
| WO-663476 | 1808 | WO-673481 | 1805 | | }1703 |
| WO-663492 | 1808 | WO-673483 | 1805 | WO-674350 | 1804 |
| WO-663493 | 1808 | WO-673497 | 1806 | | }1805 |
| WO-663595 | 2201 | WO-673498 | 1806 | | }1808 |
| WO-663596 | 2201 | WO-673501 | {1803.1 | | }2101 |
| WO-663597 | 2201 | | }2101 | WO-674364 | 1805 |
| WO-663858 | 1701 | WO-673504 | 1806 | WO-674365 | 1805 |
| WO-664418 | 1504 | WO-673511 | 1806 | WO-674408 | 1805 |
| WO-664595 | 1806 | WO-673528 | 1806 | WO-674418 | 1806 |
| WO-664933 | 1806 | WO-673553 | 1804 | WO-674425 | 1806 |
| WO-664934 | 1806 | WO-673557 | 1806 | WO-674426 | 1806 |
| WO-666197 | 1800 | WO-673561 | 1806 | WO-674427 | 1806 |
| WO-669118 | 0101 | WO-673562 | 1806 | WO-674598 | 1805 |
| WO-669904 | {0612 | WO-673569 | 2202 | WO-674621 | 2201 |
| | }1804 | WO-673577 | 1806 | WO-674622 | 2201 |
| WO-670372 | 1806 | WO-673579 | 1806 | WO-674651 | 2202 |

ORDNANCE AND MANUFACTURERS' PART NUMBER INDEX—Continued

| PART NO. | SUBGROUP | PART NO. | SUBGROUP | PART NO. | SUBGROUP |
|-----------|----------|-----------|----------|-----------|----------|
| WO-674743 | 1805 | WO-680239 | 1804 | WO-680466 | 1701 |
| WO-674789 | 2201 | WO-680241 | 1804 | WO-680475 | 1703 |
| WO-674790 | 2201 | WO-680253 | 0502 | WO-680477 | 0612 |
| WO-674882 | 1805 | WO-680255 | 0502 | WO-680478 | 0612 |
| WO-674884 | 1805 | WO-680256 | 0502 | WO-680479 | 0612 |
| | {0612 | WO-680257 | 1806 | WO-680503 | 2201 |
| | {1701 | WO-680266 | 1804 | WO-680505 | 1804 |
| WO-674898 | 1703 | WO-680270 | 1703 | WO-680506 | 1805 |
| | {1804 | WO-680274 | 0612 | WO-680509 | 1805 |
| | {1805 | WO-680283 | 1804 | WO-680559 | 1804 |
| | {1808 | WO-680284 | 1804 | WO-680561 | 0612 |
| WO-674910 | 1805 | WO-680291 | 2101 | WO-680565 | 1804 |
| WO-674919 | 1805 | WO-680292 | 2101 | WO-680566 | 1804 |
| WO-674927 | {1804 | WO-680293 | 1703 | WO-680568 | 1804 |
| | {1808 | WO-680301 | 0612 | WO-680569 | 1804 |
| WO-674939 | 1805 | WO-680302 | 1804 | WO-680575 | 1804 |
| WO-674953 | 1805 | WO-680303 | 0612 | WO-680577 | 1703 |
| WO-674956 | 1808 | WO-680306 | 0612 | WO-680580 | 1804 |
| WO-674957 | 1808 | WO-680307 | 0612 | WO-680607 | 1804 |
| WO-674959 | 1808 | WO-680309 | 1808 | WO-680624 | 1805 |
| WO-674967 | 1808 | WO-680310 | 1808 | WO-680625 | 1805 |
| | {0105.2 | WO-680312 | 1808 | WO-680627 | 1804 |
| WO-674993 | 1808 | WO-680320 | 2201 | WO-680628 | 1804 |
| | {1812 | WO-680330 | 2201 | WO-680629 | 1804 |
| WO-675071 | 1808 | WO-680333 | 2201 | WO-680630 | 1804 |
| WO-675137 | 1806 | WO-680334 | 2201 | WO-680631 | 1805 |
| WO-675141 | 2101 | WO-680340 | 0612 | WO-680632 | 1804 |
| WO-675206 | 1808 | WO-680351 | 2201 | WO-680633 | 1804 |
| WO-675567 | 1805 | WO-680371 | 1804 | WO-680634 | 1804 |
| WO-676729 | 1812 | WO-680372 | 1804 | WO-680637 | 1800 |
| WO-677149 | 2202 | WO-680381 | 0612 | WO-680641 | 1804 |
| WO-677150 | 2202 | WO-680382 | 0612 | WO-680664 | 1703 |
| WO-677153 | 2202 | WO-680398 | 1804 | WO-680679 | 2101 |
| WO-677277 | 1804 | WO-680399 | 1805 | WO-680686 | 2201 |
| WO-677412 | 2201 | WO-680402 | 1804 | WO-680687 | 0612 |
| WO-677417 | 2201 | WO-680403 | 1701 | WO-680750 | 2202 |
| WO-677418 | 2201 | WO-680404 | 1808 | WO-680751 | 1804 |
| WO-677712 | 1804 | WO-680406 | 1804 | WO-680752 | 1804 |
| WO-677786 | 0612 | WO-680409 | 2101 | WO-680768 | 2202 |
| WO-677836 | 1806 | WO-680416 | 1804 | WO-680769 | 2201 |
| WO-677927 | 1701 | WO-680420 | 2101 | WO-680787 | 2202 |
| WO-677928 | 1701 | WO-680427 | 1804 | WO-680819 | 1808 |
| WO-677963 | 1808 | WO-680430 | 1804 | WO-680821 | 1804 |
| WO-677999 | 1808 | WO-680437 | 2201 | WO-680822 | 1804 |
| WO-680001 | 1701 | WO-680439 | 1804 | WO-680935 | 1703 |
| WO-680002 | 1701 | | {1701 | WO-680936 | 1703 |
| WO-680003 | 1805 | WO-680445 | {1703 | WO-680940 | 2201 |
| WO-680123 | 0612 | | {1804 | WO-680951 | 1804 |
| WO-680125 | 1701 | | {1805 | WO-680952 | 1804 |
| WO-680128 | 1804 | WO-680446 | {1804 | WO-680956 | 1800 |
| WO-680130 | 1804 | | {1808 | WO-680974 | 1808 |
| WO-680143 | 1808 | WO-680448 | 1701 | WO-680987 | 1808 |
| WO-680144 | 1804 | WO-680450 | 2101 | WO-680991 | 1805 |
| WO-680146 | 1804 | WO-680455 | 1701 | WO-680992 | 1805 |
| WO-680149 | 1808 | WO-680456 | 1701 | WO-680993 | 1804 |
| WO-680150 | 1808 | WO-680457 | 1703 | WO-680994 | 1703 |
| WO-680156 | 1806 | WO-680460 | 0613.1 | WO-681003 | 1804 |
| WO-680159 | 1805 | WO-680465 | 1701 | WO-681004 | 1804 |

ORDNANCE AND MANUFACTURERS' PART NUMBER INDEX—Continued

| PART NO. | SUBGROUP | PART NO. | SUBGROUP | PART NO. | SUBGROUP |
|-----------|----------|------------|----------|-----------|----------|
| WO-681005 | 1804 | WO-683013 | 1812 | WO-684560 | 1800 |
| WO-681006 | 1804 | WO-683023 | 2201 | WO-684565 | 1701 |
| WO-681026 | 2202 | WO-683024 | 2201 | WO-684566 | 1701 |
| WO-681037 | 1804 | WO-683029 | 1812 | WO-684569 | 2101 |
| WO-681039 | 2101 | WO-683107 | 1808 | WO-684570 | 2101 |
| WO-681080 | 2202 | WO-683310 | 0502 | WO-684577 | 0501 |
| WO-681161 | 1806 | WO-683517 | 1701 | WO-684720 | 0612 |
| WO-681165 | 1804 | WO-683518 | 1701 | WO-684724 | 0612 |
| | 1808 | WO-683573 | 1804 | WO-684725 | 0612 |
| | 2201 | WO-683574 | 2101 | WO-684726 | 0612 |
| WO-681166 | 0612 | WO-683575 | 2101 | WO-684727 | 0612 |
| WO-681167 | 1805 | WO-683576 | 2101 | WO-684728 | 0612 |
| WO-681181 | 1804 | WO-683828 | 1504 | WO-684729 | 0612 |
| WO-681184 | 1804 | WO-683850 | 1812 | WO-684730 | 1804 |
| WO-681189 | 1806 | WO-683852 | 1504 | WO-684731 | 0612 |
| WO-681190 | 1504 | WO-683864 | 1808 | WO-684732 | 0612 |
| WO-681192 | 1808 | WO-683909 | 1805 | WO-684810 | 1804 |
| WO-681206 | 1806 | WO-683911 | 1808 | WO-684834 | 1804 |
| WO-681207 | 1806 | WO-683912 | 1812 | WO-684845 | 1808 |
| WO-681233 | 1703 | WO-683913 | 1812 | WO-684914 | 1804 |
| WO-681261 | 1808 | WO-683937 | 1804 | WO-684915 | 0501 |
| WO-681263 | 1703 | WO-683955 | 1804 | WO-684917 | 1804 |
| WO-681264 | 1808 | WO-683982 | 1812 | WO-684918 | 1804 |
| WO-681266 | 1808 | WO-683991 | 2201 | WO-684937 | 1812 |
| WO-681268 | 1804 | WO-683992 | 2201 | WO-684940 | 1812 |
| WO-681272 | 1808 | WO-684004 | 1805 | WO-684949 | 1812 |
| WO-681273 | 1808 | PR-68-4020 | 0104.1 | WO-684953 | 1812 |
| WO-681274 | 1804 | PR-68-4030 | 0104.1 | WO-684957 | 1812 |
| | 1808 | PR-68-4040 | 0104.1 | WO-684961 | 1812 |
| | 1804 | WO-684072 | 1803.1 | WO-684962 | 1812 |
| WO-681275 | 1808 | WO-684117 | 1805 | WO-684964 | 1812 |
| | 2101 | WO-684129 | 1803.1 | WO-684972 | 1812 |
| WO-681347 | 2101 | WO-684130 | 1803.1 | WO-684973 | 1812 |
| WO-681348 | 2101 | WO-684131 | 1803.1 | WO-684975 | 1812 |
| WO-681406 | 1804 | WO-684132 | 1803.1 | WO-684980 | 2201 |
| WO-681439 | 2101 | WO-684155 | 1803.1 | WO-684988 | 2201 |
| WO-681440 | 1804 | WO-684177 | 1806 | WO-684996 | 2201 |
| WO-681443 | 2101 | WO-684184 | 1806 | WO-684999 | 1812 |
| WO-681444 | 2101 | WO-684185 | 1806 | WO-685000 | 2201 |
| WO-681455 | 1804 | WO-684189 | 1804 | WO-685056 | 1804 |
| WO-681456 | 1804 | WO-684190 | 1804 | WO-685071 | 1804 |
| WO-681457 | 1804 | WO-684192 | 1805 | WO-685077 | 1808 |
| WO-681458 | 1804 | WO-684239 | 2201 | WO-685143 | 1806 |
| WO-681512 | 1804 | WO-684241 | 1804 | WO-685149 | 1806 |
| WO-681671 | 1808 | WO-684246 | 1805 | WO-685154 | 1806 |
| WO-681672 | 1808 | WO-684248 | 1805 | WO-685158 | 1806 |
| WO-681758 | 0612 | WO-684249 | 1806 | WO-685174 | 1504 |
| WO-681786 | 1804 | WO-684250 | 1806 | WO-685257 | 1805 |
| WO-681955 | 1808 | WO-684253 | 1804 | WO-685262 | 1806 |
| WO-681956 | 1808 | WO-684258 | 2201 | WO-685277 | 1808 |
| WO-682074 | 1504 | WO-684278 | 2201 | WO-685285 | 1806 |
| WO-682169 | 1701 | WO-684285 | 1701 | WO-685286 | 1806 |
| WO-682197 | 1805 | WO-684290 | 0502 | WO-685290 | 1806 |
| WO-682637 | 1804 | WO-684295 | 1808 | WO-685299 | 1808 |
| WO-682803 | 2201 | WO-684296 | 1808 | WO-685361 | 1812 |
| WO-682884 | 2201 | WO-684501 | 1701 | WO-685362 | 1504 |
| WO-683000 | 2201 | WO-684538 | 0502 | WO-685363 | 1504 |
| WO-683003 | 2201 | WO-684555 | 1804 | WO-685366 | 1812 |
| WO-683009 | 1805 | | | | |

ORDNANCE AND MANUFACTURERS' PART NUMBER INDEX—Continued

| PART NO. | SUBGROUP | PART NO. | SUBGROUP | PART NO. | SUBGROUP |
|-----------------|-----------------|-----------------|-----------------|-----------------|-----------------|
| WO-685369 | 1806 | WO-685790 | 1808 | WO-691543 | 1812 |
| WO-685380 | 1504 | WO-685809 | 1808 | WO-691544 | 1812 |
| WO-685384 | 1806 | WO-685810 | 1808 | WO-691545 | 1806 |
| WO-685386 | 1806 | WO-685813 | 1808 | WO-691546 | 1806 |
| WO-685387 | 1806 | WO-685815 | 1808 | WO-691547 | 1806 |
| WO-685388 | {1804 | WO-685838 | 1803.1 | WO-691549 | 1806 |
| | 1812 | WO-685850 | 1812 | WO-691550 | 1806 |
| WO-685389 | 1504 | WO-685851 | 1812 | WO-691551 | 1806 |
| WO-685403 | 0502 | WO-685853 | 1812 | WO-691552 | 1806 |
| WO-685404 | 0502 | WO-685854 | 1812 | WO-691553 | 1806 |
| WO-685405 | 0502 | WO-685856 | 1812 | WO-691593 | 1805 |
| WO-685406 | 0502 | WO-685858 | 1812 | WO-K700695 | 1501 |
| WO-685424 | 1812 | WO-685865 | 2201 | RG-O78053-9¼ | 1401 |
| WO-685433 | 1812 | WO-685867 | 1805 | TRI-79016-4 | 2202 |
| WO-685434 | 1804 | WO-685901 | 1800 | WO-800002 | 0504 |
| WO-685447 | 1800 | WO-685902 | 2201 | WO-800023 | 1204.1 |
| WO-685449 | 1806 | WO-685904 | 1812 | WO-800044 | 1313 |
| WO-685451 | 1812 | WO-685910 | 2201 | WO-800048 | 1501 |
| WO-685452 | 1812 | WO-685911 | 1808 | WO-800051 | 1503 |
| WO-685453 | 2201 | WO-685912 | 1808 | WO-800068 | 1004 |
| WO-685456 | 1804 | WO-685913 | 1808 | WO-800078 | 2101 |
| WO-685467 | 1806 | WO-685914 | 1808 | WO-800079 | 0700 |
| WO-685468 | 1804 | WO-685928 | 1812 | WO-800093 | 0102.1 |
| WO-685471 | 1808 | WO-685930 | 1812 | WO-800095 | 1004 |
| WO-685472 | 1812 | WO-686135 | 2201 | WO-800127 | 0602 |
| WO-685500 | 1806 | WO-686143 | 2201 | WO-800173 | 0105.2 |
| WO-685506 | 1806 | WO-686144 | 2201 | WO-800193 | 0612 |
| WO-685507 | 1806 | WO-686145 | 2201 | WO-800200 | 0105.2 |
| WO-685513 | 1806 | WO-686146 | 2201 | WO-800213 | 0610 |
| WO-685514 | 1806 | WO-686152 | 2201 | WO-800226 | 1703 |
| WO-685517 | 1806 | WO-687079 | 1806 | WO-800293 | 0503 |
| WO-685521 | 1806 | WO-687255 | 1806 | WO-800337 | 1503 |
| WO-685525 | 1806 | WO-687682 | 1804 | WO-800338 | 1503 |
| WO-685527 | 1812 | WO-687869 | 1806 | WO-800347 | 0304.5 |
| WO-685528 | 1812 | WO-687887 | 1812 | WO-800361 | 0302.1 |
| WO-685536 | 2201 | WO-687889 | 1812 | WO-800378 | 0609.1 |
| WO-685537 | 2201 | WO-687912 | 1812 | WO-800390 | 2101 |
| WO-685539 | 2201 | WO-687914 | 1812 | WO-800391 | 0617 |
| WO-685540 | 2201 | WO-688119 | 1812 | WO-800392 | 0617 |
| WO-685544 | 2201 | WO-688231 | 1701 | WO-800393 | 0607 |
| WO-685545 | 2201 | WO-688232 | 1701 | WO-800417 | 0105.1 |
| WO-685555 | 2201 | WO-688233 | 1701 | | 0607 |
| WO-685560 | 2201 | WO-688234 | 1701 | | 0609.1 |
| WO-685566 | 1806 | WO-688998 | 1504 | WO-800422 | 0609.2 |
| WO-685567 | 1806 | WO-689016 | 1504 | | 0613.1 |
| WO-685568 | 1806 | WO-689023 | 1504 | | 0617 |
| WO-685569 | 1806 | WO-689537 | 1801 | WO-800425 | 0613.1 |
| WO-685679 | 1805 | WO-691357 | 1804 | WO-800426 | 0613.1 |
| WO-685709 | 1812 | WO-691358 | 1804 | WO-800451 | 0607 |
| WO-685716 | 2201 | WO-691393 | 1806 | WO-800452 | 0607 |
| WO-685721 | 1804 | WO-691394 | 1806 | WO-800467 | 0613.1 |
| WO-685739 | 1804 | WO-691395 | 1806 | WO-800517 | 0105.3 |
| WO-685781 | 1812 | WO-691396 | 1812 | WO-800527 | 1206 |
| WO-685783 | 1812 | WO-691397 | 1812 | WO-800537 | 2210 |
| WO-685785 | 1812 | WO-691537 | 1806 | WO-800549 | 0106.6 |
| WO-685786 | 1808 | WO-691539 | 1806 | WO-800550 | 0105.2 |
| WO-685787 | 1808 | WO-691540 | 1806 | WO-800580 | 2001.1 |
| WO-685789 | {1806 | WO-691541 | 1806 | WO-800589 | 0105.2 |
| | 1808 | | | | |

ORDNANCE AND MANUFACTURERS' PART NUMBER INDEX—Continued

| PART NO. | SUBGROUP | PART NO. | SUBGROUP | PART NO. | SUBGROUP |
|-----------|----------|-----------|----------|-----------|----------|
| WO-800605 | 1501 | WO-801238 | 0601.1 | WO-801566 | 1401 |
| WO-800699 | 0612 | WO-801243 | 0613.1 | WO-801568 | 1805 |
| WO-800713 | 1204.1 | WO-801244 | {1601.1 | WO-801660 | {0701 |
| WO-800730 | 1313 | | {1601.3 | | {0801 |
| WO-800737 | 1401 | WO-801245 | {1601.1 | | {1004 |
| WO-800741 | 0302.1 | | {1601.3 | WO-801661 | {1501 |
| WO-800766 | 2210 | WO-801247 | {0601.1 | | {1504 |
| WO-800781 | 1501 | | {0601.3 | WO-801662 | 1206 |
| WO-800783 | 0312 | WO-801249 | 0613.1 | WO-801663 | 1206 |
| WO-800798 | 1311 | WO-801250 | 0613.1 | WO-801664 | 1206 |
| WO-800799 | 0401 | WO-801251 | 0613.1 | WO-801666 | 1401 |
| WO-800802 | 2202 | WO-801252 | 0613.1 | WO-801682 | 1503 |
| WO-800803 | 0312 | WO-801263 | 0306 | WO-801692 | {0607 |
| WO-800804 | 0312 | WO-801264 | 1401 | | {0609.1 |
| WO-800809 | 0100.2 | WO-801265 | 1401 | | {0609.2 |
| WO-800817 | 1503 | WO-801266 | 0306 | | {0611 |
| WO-800818 | 0804 | WO-801279 | 1401 | | {0613.1 |
| WO-800820 | 1503 | WO-801328 | 0801 | | {0617 |
| WO-800821 | 1601.1 | WO-801330 | 0804 | WO-801693 | 0613.1 |
| WO-800823 | 1601.1 | WO-801331 | 0804 | WO-801694 | 0612 |
| WO-800825 | 1501 | WO-801332 | 0804 | WO-801695 | 1501 |
| WO-800826 | 0105.1 | WO-801367 | {0802.7 | WO-801697 | 0612 |
| WO-800827 | 0105.1 | | {1002 | WO-801699 | 0505 |
| WO-800828 | 0105.1 | WO-801371 | 0104.1 | WO-801707 | 1311 |
| WO-800829 | 0105.1 | WO-801386 | 2101 | WO-801708 | 1311 |
| WO-800867 | 1401 | WO-801393 | 1204.5 | WO-801709 | 1311 |
| WO-800868 | 1401 | WO-801394 | 1204.5 | WO-801728 | 0501 |
| WO-800876 | 0607 | WO-801422 | 1401 | WO-801730 | 0704 |
| WO-800885 | 0504 | WO-801423 | 1401 | WO-801731 | 0704 |
| WO-800896 | 1204.5 | WO-801425 | 1401 | WO-801732 | 0704 |
| WO-800906 | 0611 | WO-801458 | {0607 | WO-801733 | 0704 |
| WO-800929 | 1503 | | {0609.2 | WO-801735 | 1601.3 |
| WO-800952 | 1204.5 | | {0607 | WO-801736 | 1601.3 |
| WO-800953 | 1204.5 | WO-801460 | {0609.2 | WO-801759 | 1004 |
| WO-800978 | 0304.5 | | {0613.1 | WO-801762 | 1311 |
| WO-800986 | 0105.1 | WO-801476 | 0104.1 | WO-801766 | 2001.1 |
| WO-800995 | 2202 | WO-801480 | 0104.1 | WO-801767 | 2001.1 |
| WO-801000 | 0101 | WO-801492 | 0104.1 | WO-801768 | 2001.1 |
| WO-801042 | 0800 | WO-801493 | 0104.1 | WO-801770 | 2001.3 |
| WO-801043 | 0800 | WO-801494 | 0104.1 | WO-801771 | 2001.3 |
| WO-801045 | {1601.1 | WO-801495 | 0104.1 | WO-801772 | 2001.3 |
| | {1601.3 | WO-801496 | 0104.1 | WO-801773 | 2001.3 |
| WO-801047 | 0503 | WO-801500 | 0104.1 | WO-801774 | 2002.1 |
| WO-801048 | 0504 | WO-801502 | 0104.1 | WO-801778 | 1503 |
| WO-801049 | 0504 | WO-801503 | 0104.1 | WO-801779 | 1503 |
| WO-801053 | 0100.2 | WO-801504 | 0104.1 | WO-801780 | 1503 |
| WO-801058 | 1805 | WO-801529 | 0613.1 | WO-801781 | 1503 |
| WO-801081 | 0304.5 | WO-801531 | 0617 | WO-801782 | 1503 |
| WO-801084 | 0304.5 | WO-801534 | 0104.1 | WO-801784 | 1503 |
| WO-801085 | 0304.5 | WO-801535 | 0104.1 | WO-801785 | 1503 |
| WO-801183 | 0802.5 | WO-801536 | 0104.1 | WO-801786 | 1503 |
| WO-801186 | 1401 | WO-801538 | 0104.1 | WO-801787 | 1503 |
| WO-801192 | 0613.1 | WO-801539 | 0104.1 | WO-801790 | 2210 |
| WO-801193 | {0613.1 | WO-801540 | 0104.1 | WO-801797 | 0603 |
| | {0617 | WO-801550 | 1401 | | {0612 |
| WO-801194 | 0613.1 | WO-801561 | 0306 | WO-801809 | {0613.1 |
| WO-801201 | {0613.1 | WO-801562 | 0306 | | {2208.1 |
| | {0617 | WO-801565 | 1401 | WO-801816 | 1401 |

ORDNANCE AND MANUFACTURERS' PART NUMBER INDEX—Continued

| PART NO. | SUBGROUP | PART NO. | SUBGROUP | PART NO. | SUBGROUP |
|-----------|----------|-----------|----------|-----------|----------|
| WO-801819 | 2210 | WO-802608 | 0309 | WO-804766 | 0100.1 |
| WO-801820 | 2210 | WO-802612 | 0704 | WO-804782 | 0613.1 |
| WO-801848 | 2002.5 | WO-802613 | 0309 | WO-804783 | 0608 |
| WO-801860 | 0609.1 | WO-802634 | 2210 | WO-804784 | 0608 |
| WO-801868 | 2001.3 | WO-802635 | 0612 | WO-804805 | 0201 |
| WO-801869 | 2001.3 | WO-802665 | 0304.5 | WO-804812 | 0103 |
| WO-801899 | 1313 | WO-802765 | 1503 | WO-804821 | 1311 |
| WO-801900 | 1313 | WO-802768 | 1503 | WO-804826 | 0301 |
| WO-801901 | 1313 | WO-802825 | 1601.1 | WO-804873 | 0610 |
| WO-801926 | 1002 | WO-802887 | 1104.1 | WO-804975 | {0615 |
| WO-801927 | 1002 | WO-802925 | 0103 | | {1202 |
| WO-801929 | 1002 | WO-802954 | 1601.1 | WO-805003 | {0306 |
| WO-801933 | 0106.2 | WO-803202 | 1401 | | {0608 |
| WO-801937 | 1204.1 | WO-803203 | 1401 | WO-805004 | {1804 |
| | {0607 | WO-803357 | 0312 | | {1812 |
| WO-801977 | {0609.2 | WO-803358 | {0312 | WO-805005 | 1812 |
| | {0613.1 | | {1201 | WO-805014 | 0202 |
| WO-802087 | 0106.2 | WO-804041 | 2002.5 | WO-805015 | 0202 |
| WO-802088 | 0801 | WO-804201 | 1204.5 | WO-805016 | 0202 |
| WO-802187 | 0505 | WO-804276 | 0304.5 | WO-805017 | 0201 |
| WO-802255 | 2001.1 | WO-804277 | {0106.5 | WO-805129 | 2208.1 |
| WO-802295 | 0105.2 | | {0304.5 | WO-805130 | 2208.1 |
| WO-802298 | 1204.5 | WO-804289 | 0103 | WO-805238 | 1204.1 |
| WO-802300 | 1001 | WO-804306 | 0103 | WO-805367 | 0105.2 |
| WO-802311 | 0900 | WO-804314 | 0103 | WO-805368 | 0105.2 |
| WO-802314 | 1006 | WO-804319 | 0610 | WO-805374 | 0105.2 |
| WO-802315 | 1006 | WO-804362 | 0603 | WO-805375 | 0105.2 |
| WO-802316 | 1006 | WO-804367 | 0103 | WO-805376 | 0105.2 |
| WO-802319 | 1006 | WO-804373 | 1804 | WO-805377 | 0105.2 |
| WO-802320 | 1006 | WO-804376 | 0603 | WO-805378 | 0105.2 |
| WO-802321 | 1006 | WO-804377 | 0103 | WO-805472 | 0101 |
| WO-802382 | 2202 | WO-804379 | 0103 | WO-805478 | 0312 |
| WO-802410 | 0201 | WO-804385 | 1401 | WO-805479 | 0312 |
| WO-802411 | 0201 | WO-804386 | 1401 | WO-805480 | 0312 |
| WO-802414 | 0702.5 | WO-804387 | 1401 | WO-805483 | 0312 |
| WO-802428 | 0609.1 | WO-804390 | 1401 | WO-805512 | 1501 |
| WO-802429 | 0609.1 | WO-804391 | 1401 | WO-805513 | 1503 |
| WO-802430 | 0609.1 | WO-804392 | 1401 | WO-805514 | 1501 |
| WO-802454 | {1601.1 | WO-804396 | 0603 | WO-805515 | 1501 |
| | {1601.3 | WO-804399 | 1401 | WO-805518 | 1501 |
| WO-802496 | 0106.2 | WO-804402 | 0202 | WO-805519 | 1501 |
| WO-802498 | 1004 | WO-804417 | 0103 | WO-805520 | 1501 |
| WO-802509 | 1204.5 | WO-804418 | 0103 | WO-805522 | 0100.2 |
| WO-802550 | 1204.3 | WO-804453 | 1501 | WO-805545 | 0312 |
| WO-802551 | 1204.3 | WO-804484 | 0106.1 | WO-805546 | 0312 |
| WO-802552 | 1101 | WO-804486 | 0106.1 | WO-805547 | 0312 |
| WO-802556 | 1101 | WO-804488 | 0100.2 | WO-805548 | 0312 |
| WO-802557 | 1102 | WO-804535 | 1401 | WO-805552 | 1501 |
| WO-802558 | 1102 | WO-804611 | 2002.5 | WO-805555 | 1501 |
| WO-802559 | 1102 | WO-804622 | 0105.2 | WO-805556 | 1501 |
| WO-802560 | 1102 | WO-804623 | 0611 | WO-805574 | 0608 |
| WO-802561 | 1102 | WO-804639 | 0607 | WO-805575 | 1501 |
| WO-802562 | 1102 | WO-804744 | 0202 | WO-805576 | 1501 |
| WO-802563 | 1102 | WO-804745 | 0202 | WO-805580 | {1601.1 |
| WO-802564 | 1102 | WO-804746 | 0201 | | {1601.3 |
| WO-802576 | 0105.3 | WO-804758 | 0603 | WO-805592 | 1202 |
| WO-802579 | 0704 | WO-804764 | 2002.5 | WO-805602 | 1202 |
| WO-802587 | 0105.1 | WO-804765 | 2002.5 | WO-805635 | 1501 |

ORDNANCE AND MANUFACTURERS' PART NUMBER INDEX—Continued

| PART NO. | SUBGROUP | PART NO. | SUBGROUP | PART NO. | SUBGROUP |
|-----------|----------|-----------|----------|-----------|----------|
| WO-805643 | 1501 | WO-806146 | 0104.1 | WO-806435 | 0304.5 |
| WO-805676 | 1401 | WO-806153 | 0306 | WO-806441 | 0304.1 |
| WO-805677 | 1401 | WO-806158 | 0306 | WO-806445 | 0304.5 |
| WO-805715 | 1501 | WO-806162 | 1204.1 | WO-806446 | 0304.5 |
| WO-805719 | 1501 | WO-806163 | 1204.5 | WO-806447 | 0304.5 |
| WO-805727 | 0302.1 | WO-806172 | 0306 | WO-806449 | 0304.5 |
| WO-805728 | 0312 | WO-806184 | 0306 | WO-806450 | 0607 |
| WO-805730 | 0101 | WO-806185 | 0304.1 | WO-806451 | 0304.1 |
| WO-805767 | 0103 | WO-806186 | 0304.5 | WO-806515 | 0106.6 |
| WO-805768 | 0103 | WO-806187 | 0304.1 | WO-806626 | 0309 |
| WO-805777 | 1201 | WO-806192 | 0103 | WO-806627 | 0309 |
| WO-805778 | 1201 | WO-806206 | 0101 | WO-806663 | 0306 |
| WO-805779 | 0401 | WO-806216 | 1501 | WO-806664 | 0306 |
| WO-805783 | 1004 | WO-806217 | 1501 | WO-806673 | {0612 |
| WO-805784 | 1004 | WO-806218 | 1501 | | }1804 |
| WO-805788 | 1000 | WO-806219 | 1501 | WO-806674 | 1804 |
| WO-805789 | 1000 | WO-806262 | 0605 | WO-806675 | 0611 |
| WO-805791 | 1100 | WO-806266 | 0101 | WO-806718 | 2208.1 |
| WO-805815 | 0106.2 | WO-806271 | 0301 | WO-806719 | 2208.1 |
| WO-805816 | 0106.6 | WO-806279 | 0101 | WO-806721 | 1204.5 |
| WO-805820 | 0503 | WO-806280 | 0101 | WO-806746 | 1401 |
| WO-805821 | 0503 | WO-806281 | 0101 | WO-806749 | 1401 |
| WO-805822 | 0503 | WO-806288 | 0101 | WO-806750 | 1401 |
| WO-805823 | 0501 | WO-806317 | 0105.2 | WO-806752 | 1401 |
| WO-805824 | 0501 | WO-806318 | 0105.2 | WO-806764 | 0505 |
| WO-805825 | 0501 | WO-806320 | 0105.2 | WO-806772 | 2210 |
| WO-805842 | 0302.1 | WO-806322 | 0502 | WO-806773 | 2210 |
| WO-805896 | 0103 | WO-806330 | 0604.1 | WO-806776 | 2210 |
| WO-805905 | 0306 | WO-806333 | 0312 | WO-806832 | 0610 |
| WO-805912 | 0309 | WO-806334 | 0312 | WO-806857 | 2210 |
| WO-805913 | 0309 | WO-806335 | 0312 | WO-806876 | 0100.2 |
| WO-805914 | 0610 | WO-806337 | 0312 | WO-806877 | 0101 |
| WO-805935 | 0202 | WO-806338 | 0312 | WO-806878 | 0100.2 |
| WO-806009 | 2001.3 | WO-806339 | 0312 | WO-806879 | 0100.2 |
| WO-806012 | 0202 | WO-806348 | 0105.1 | WO-806909 | {1601.1 |
| WO-806024 | 0802.7 | WO-806357 | 0304.1 | | }1601.3 |
| WO-806025 | 1201 | WO-806359 | 0304.5 | WO-806910 | 1501 |
| WO-806026 | 1201 | WO-806363 | 0607 | WO-806915 | 0611 |
| WO-806027 | 1201 | WO-806369 | 1401 | WO-806916 | 0611 |
| WO-806028 | 1201 | WO-806370 | 1401 | WO-806917 | 1401 |
| WO-806034 | 1201 | WO-806371 | 1401 | WO-806950 | 0312 |
| WO-806035 | 1201 | WO-806372 | 1401 | WO-806952 | 0312 |
| WO-806036 | 0802.7 | WO-806384 | 0612 | WO-806953 | 0312 |
| WO-806037 | 0802.5 | WO-806388 | 0612 | WO-806968 | 1601.1 |
| WO-806038 | 0802.7 | WO-806389 | 0612 | WO-806969 | 1601.3 |
| WO-806044 | 0800 | WO-806393 | 0611 | WO-806991 | 0106.6 |
| WO-806045 | 0802.7 | WO-806409 | 0613.1 | WO-807005 | 0101 |
| WO-806064 | 0304.5 | WO-806410 | 0613.1 | WO-807036 | 0101 |
| WO-806065 | 0306 | WO-806412 | 0611 | WO-807111 | 0612 |
| WO-806072 | 0601.3 | WO-806413 | 0613.1 | WO-807112 | 0611 |
| WO-806115 | 1201 | WO-806415 | 0613.1 | WO-807134 | 0306 |
| WO-806116 | 1201 | WO-806417 | 0613.1 | WO-807154 | 0617 |
| WO-806117 | 1201 | WO-806419 | 0304.5 | WO-807164 | 0309 |
| WO-806118 | 1201 | WO-806420 | 0304.5 | WO-807166 | 0304.5 |
| WO-806141 | 0306 | WO-806424 | 0201 | WO-807176 | 0312 |
| WO-806143 | 0104.1 | WO-806428 | 0304.5 | WO-807196 | 0613.1 |
| WO-806144 | 0104.1 | WO-806430 | 1401 | WO-807202 | 0605 |
| WO-806145 | 0104.1 | WO-806433 | 0304.5 | WO-807203 | 1204.1 |

ORDNANCE AND MANUFACTURERS' PART NUMBER INDEX—Continued

| PART NO. | SUBGROUP | PART NO. | SUBGROUP | PART NO. | SUBGROUP |
|-----------|----------|-----------|----------|-----------|----------|
| WO-807204 | 1204.1 | WO-807695 | 0802.5 | WO-808461 | 1601.1 |
| WO-807205 | 0306 | WO-807700 | 0304.5 | WO-808462 | 1601.3 |
| WO-807208 | {0202 | WO-807706 | 0106.6 | WO-808466 | 1601.3 |
| | 1206 | WO-807707 | 0105.1 | WO-808467 | 1601.1 |
| WO-807266 | 1002 | WO-807708 | 0105.1 | WO-808476 | {0100.1 |
| WO-807267 | 1101 | WO-807709 | 0105.1 | | 0503 |
| WO-807279 | {0613.1 | WO-807710 | 0503 | WO-808503 | 0607 |
| | 0617 | WO-807711 | 0304.5 | WO-808519 | 0607 |
| WO-807281 | 1202 | WO-807713 | 0106.5 | WO-808565 | 0607 |
| WO-807282 | 1202 | WO-807719 | 1501 | WO-808566 | 0607 |
| WO-807283 | 1202 | WO-807737 | 0605 | WO-808567 | 0610 |
| WO-807284 | 1202 | WO-807738 | 0605 | WO-808568 | 0607 |
| WO-807292 | 1202 | WO-807739 | 0605 | WO-808569 | 0607 |
| WO-807311 | 0607 | WO-807762 | 0103 | WO-808595 | 1311 |
| WO-807325 | 0306 | WO-807767 | 0802.7 | WO-808610 | 0613.1 |
| WO-807327 | {0202 | WO-807779 | 0900 | WO-808622 | 0607 |
| | 1206 | WO-807780 | 0900 | WO-808666 | 0100.1 |
| WO-807328 | 0202 | WO-807781 | 0900 | WO-808668 | 1605 |
| WO-807329 | 1206 | WO-807784 | 0900 | WO-808672 | 1605 |
| WO-807330 | 0306 | WO-807787 | 1501 | WO-808678 | 1605 |
| WO-807331 | 0306 | WO-807801 | 0900 | WO-808693 | 1605 |
| WO-807342 | 0105.1 | WO-807810 | 0304.5 | WO-808699 | 1605 |
| WO-807355 | 0306 | WO-807811 | 0304.5 | WO-808703 | 1605 |
| WO-807356 | 1204.3 | WO-807845 | 2202 | WO-808707 | 1601.3 |
| WO-807357 | 1204.3 | WO-807846 | 2202 | WO-808708 | 1601.3 |
| WO-807367 | 1202 | WO-807872 | 1000 | WO-808709 | 1601.1 |
| WO-807371 | 1202 | WO-807873 | 1000 | WO-808710 | 1601.1 |
| WO-807374 | 1202 | WO-807874 | 1100 | WO-808713 | 1605 |
| WO-807375 | 1202 | WO-807875 | 1100 | WO-808714 | 1605 |
| WO-807377 | 1202 | WO-807889 | 0103 | WO-808716 | 1605 |
| WO-807378 | 1202 | WO-807892 | 0802.5 | WO-808717 | 1605 |
| WO-807386 | 0106.5 | WO-807941 | 0104.2 | WO-808769 | 1311 |
| WO-807390 | 0106.6 | WO-807944 | 0104.2 | WO-808770 | 1311 |
| WO-807392 | 0106.6 | WO-807947 | 0104.2 | WO-808774 | {0613.1 |
| WO-807400 | 0304.1 | WO-807948 | 0104.2 | | 2202 |
| WO-807411 | 1204.3 | WO-807971 | 1808 | WO-808788 | 1501 |
| WO-807430 | 0304.5 | WO-808137 | {0309 | WO-808789 | 1501 |
| WO-807466 | 2210 | | 0610 | WO-808790 | 1501 |
| WO-807471 | 0202 | WO-808319 | 0501 | WO-808793 | 0104.1 |
| WO-807472 | 1401 | WO-808333 | 0312 | WO-808794 | 0104.1 |
| WO-807473 | 1401 | WO-808359 | 0106.6 | WO-808795 | 0104.1 |
| WO-807474 | 1401 | WO-808363 | 0306 | WO-808797 | 0104.1 |
| WO-807475 | 1401 | WO-808364 | 0306 | WO-808798 | 0104.1 |
| WO-807476 | 1401 | WO-808374 | 2202 | WO-808799 | 0104.1 |
| WO-807477 | 1401 | WO-808385 | 0106.1 | WO-808858 | 0702.1 |
| WO-807478 | 1401 | WO-808414 | 1401 | WO-808905 | 1204.5 |
| WO-807479 | 1401 | WO-808421 | 0604.1 | WO-808906 | 1601.3 |
| WO-807480 | 1401 | WO-808438 | 1202 | WO-808910 | 1601.3 |
| WO-807488 | 0202 | WO-808440 | 1202 | WO-808913 | 2208.1 |
| WO-807495 | 0304.5 | WO-808441 | 1202 | WO-808925 | 0306 |
| WO-807499 | 1201 | WO-808442 | 1401 | WO-808926 | 0304.5 |
| WO-807564 | 1503 | WO-808444 | 1401 | WO-808936 | 0202 |
| WO-807578 | 1503 | WO-808445 | 0607 | WO-808945 | 1501 |
| WO-807587 | 1501 | WO-808450 | 1604.1 | WO-808969 | 2101 |
| WO-807690 | 0900 | WO-808451 | 1604.1 | WO-808980 | 0401 |
| WO-807691 | 0900 | WO-808458 | 1601.1 | WO-808981 | 0401 |
| WO-807693 | 1102 | WO-808459 | 1601.3 | WO-808988 | 1601.1 |
| WO-807694 | 1002 | WO-808460 | 1601.1 | WO-808998 | 0306 |

ORDNANCE AND MANUFACTURERS' PART NUMBER INDEX—Continued

| PART NO. | SUBGROUP | PART NO. | SUBGROUP | PART NO. | SUBGROUP |
|-----------|----------|-----------|----------|---------------|----------|
| WO-809021 | 0104.1 | WO-809828 | 0607 | WO-811657 | 2210 |
| WO-809022 | 0104.1 | WO-809829 | 0607 | WO-811673 | 1503 |
| WO-809023 | 0104.1 | WO-809830 | 0607 | WO-811687 | {0802.5 |
| WO-809025 | 0104.1 | WO-809831 | 0607 | | {0802.7 |
| WO-809026 | 0104.1 | WO-809832 | 0607 | WO-811867 | 0617 |
| WO-809027 | 0104.1 | WO-809885 | 0304.1 | WO-811890 | {1601.1 |
| WO-809045 | 0104.1 | WO-809916 | 0106.6 | | {1601.3 |
| WO-809047 | 0104.1 | WO-809959 | 0611 | WO-811900 | 0617 |
| WO-809048 | 0104.1 | WO-810058 | 0501 | WO-811911 | 0612 |
| WO-809049 | 0104.1 | WO-810081 | 1006 | WO-811913 | 1605 |
| WO-809078 | 1401 | WO-810082 | 1006 | WO-811914 | 1605 |
| WO-809082 | 1204.1 | WO-810085 | 1006 | WO-812050 | 0503 |
| WO-809083 | 0304.1 | WO-810086 | 1006 | WO-812250 | 0610 |
| WO-809084 | 0106.5 | WO-810091 | 1006 | MAT-8215-22 | 1601.1 |
| WO-809118 | 1501 | WO-810092 | 1006 | MAT-8215-23 | 1601.1 |
| WO-809119 | 0501 | WO-810095 | 1006 | MAT-8215-24 | 1601.1 |
| WO-809120 | 0501 | WO-810111 | 0306 | MAT-8215-25 | {1601.1 |
| WO-809121 | 1501 | WO-810112 | 0306 | | {1601.3 |
| WO-809126 | 0306 | WO-810197 | 0613.1 | MAT-8215-26 | {1601.1 |
| WO-809149 | 1604.1 | WO-810198 | 0613.1 | | {1601.3 |
| WO-809161 | 1604.1 | WO-810284 | 0610 | MAT-8215-27 | {1601.1 |
| WO-809162 | 1503 | WO-810289 | 0302.1 | | {1601.3 |
| WO-809173 | 0611 | WO-810491 | 0304.1 | MAT-8215-28 | {1601.1 |
| WO-809189 | 1401 | WO-810542 | {1601.1 | | {1601.3 |
| WO-809190 | 1401 | | {1601.3 | MAT-8216-22 | 1601.3 |
| WO-809191 | 1401 | WO-810548 | 0613.1 | MAT-8216-23 | 1601.3 |
| WO-809192 | 1401 | WO-810549 | 0613.1 | MAT-8216-24 | 1601.3 |
| WO-809200 | 1401 | WO-810557 | 0312 | MAT-8216-25 | 1601.3 |
| WO-809228 | 0201 | WO-810579 | {1601.1 | MAT-8216-26 | {1601.1 |
| WO-809236 | {1601.1 | | {1601.3 | | {1601.3 |
| | {1601.3 | WO-810592 | 0312 | MAT-8216-27 | {1601.1 |
| WO-809246 | 0304.5 | WO-810607 | 0900 | | {1601.3 |
| WO-809251 | 0610 | WO-810822 | 1201 | MAT-8216-28 | {1601.1 |
| WO-809260 | 0613.1 | WO-810823 | 1201 | | {1601.3 |
| WO-809261 | 0613.1 | WO-810893 | 0609.2 | GM-838263 | 0302.1 |
| WO-809304 | 0103 | WO-810894 | 0609.2 | AC-855029 | 0302.1 |
| WO-809403 | 0306 | WO-810895 | 0609.2 | CC-856464 | 0702.3 |
| WO-809404 | 0306 | WO-811211 | 2210 | CC-856470 | 0702.3 |
| WO-809429 | 1201 | WO-811243 | 0607 | CC-856471 | 0702.3 |
| WO-809517 | 0106.6 | WO-811244 | 0607 | TRI-86520-1 | 2202 |
| WO-809548 | 1101 | WO-811245 | 0607 | TRI-86521-3 | 2202 |
| WO-809596 | 1804 | WO-811246 | 0607 | SCI-L8719-32 | 0617 |
| WO-809624 | 0615 | WO-811285 | 2210 | TRI-P87350-1J | 2202 |
| WO-809626 | 0601.1 | WO-811286 | 2210 | WO-905744 | 0306 |
| WO-809656 | 0106.5 | WO-811292 | 0401 | WO-905745 | 0306 |
| WO-809689 | 0302.1 | WO-811293 | 0401 | WO-905857 | 1204.5 |
| WO-809706 | {0700 | WO-811351 | 1311 | WO-905858 | 1204.5 |
| | {2001.3 | WO-811407 | 1401 | WO-906054 | 0610 |
| WO-809723 | 1401 | WO-811417 | 0306 | WO-906062 | 0306 |
| WO-809807 | {1601.1 | WO-811418 | 0306 | WO-906171 | 1204.1 |
| | {1601.3 | WO-811439 | 0306 | WO-906263 | 1501 |
| WO-809816 | 0610 | WO-811440 | 0306 | WO-906408 | 1501 |
| WO-809817 | 0607 | WO-811473 | 1201 | WO-906424 | 1501 |
| WO-809819 | 2208.1 | WO-811475 | 1201 | WO-906638 | {0202 |
| WO-809820 | 0610 | WO-811540 | 0401 | | {1206 |
| WO-809821 | 0607 | WO-811545 | 1605 | WO-906703 | 1006 |
| WO-809822 | 0607 | WO-811598 | 1201 | WO-906739 | 1501 |
| WO-809823 | 0607 | WO-811645 | 1204.1 | WO-907147 | 1501 |

ORDNANCE AND MANUFACTURERS' PART NUMBER INDEX—Continued

| PART NO. | SUBGROUP | PART NO. | SUBGROUP | PART NO. | SUBGROUP |
|--------------|----------|----------------|----------|--------------|----------|
| WO-907818 | 1601.1 | AC-1523122 | 0302.1 | DR-1916107 | 0601.3 |
| WO-907838 | 1601.1 | AC-1523221 | 0302.1 | DR-1916133 | 0601.3 |
| WO-907878 | 0101 | AC-1523259 | 0302.1 | DR-1916134 | 0601.3 |
| WO-907879 | 0105.3 | AC-1523664 | 0302.1 | DR-1916135 | 0601.3 |
| WO-908301 | 1102 | AC-1523802 | 0302.1 | DR-1916137 | 0601.3 |
| WO-908715 | 0302.1 | AC-1523803 | 0302.1 | DR-1916139 | 0601.3 |
| WO-908767 | 0609.1 | AC-1523805 | 0302.1 | DR-1916140 | 0601.3 |
| WO-908768 | 0609.1 | AC-1537096 | 0302.1 | DR-1916141 | 0601.3 |
| WO-909342 | 2210 | AC-1537195 | 0302.1 | DR-1916143 | 0601.3 |
| WO-909393 | {0103 | AC-1537811 | 0302.1 | DR-1916149 | 0601.3 |
| | {1202 | AC-1538355 | 0302.1 | DR-1916150 | 0601.3 |
| WO-909548 | 1311 | AC-1538356 | 0302.1 | DR-1916152 | 0601.3 |
| WO-909663 | 1501 | AC-1538357 | 0302.1 | DR-1916153 | 0601.3 |
| GL-918888 | 0609.1 | AC-1538358 | 0302.1 | DR-1916154 | 0601.3 |
| GL-923121 | 0609.1 | AC-1539810 | 0302.1 | DR-1916155 | 0601.3 |
| GL-928562 | 0607 | AC-1542836 | 0304.5 | DR-1916157 | 0601.3 |
| GL-929353 | 0607 | AC-1542837 | 0304.5 | DR-1916158 | 0601.3 |
| RG-9472-42 % | 1401 | AC-1542947 | 0304.5 | DR-1916160 | 0601.3 |
| WO-950984 | 1808 | AC-1543013 | 0304.5 | DR-1916209 | 0601.3 |
| IHC-103299K1 | 0609.1 | AC-1543018 | 0304.5 | DR-1916211 | 0601.3 |
| IHC-103305R1 | 0609.1 | AC-1567648 | 0302.1 | DR-1916320 | 0601.3 |
| DR-1117495 | 0601.3 | AC-1568220 | 2208.1 | DR-1916321 | 0601.3 |
| CC-1271718 | 0609.2 | AC-1568362 | 2208.1 | DR-1916322 | 0601.3 |
| CC-1273325 | 0609.1 | AC-1580260 | 2208.1 | DR-1916325 | 0601.3 |
| CC-1273326 | 0609.1 | AC-1580377 | 0607 | DR-1916413 | 0601.3 |
| CC-1273357 | 0609.1 | AC-1580677 | 0607 | DR-1916415 | 0601.3 |
| CC-1273439 | 0601.1 | AC-1580678 | 0607 | DR-1916416 | 0601.3 |
| CC-1273972 | 0609.1 | AC-1580684 | 0607 | DR-1916417 | 0601.3 |
| AC-1411094 | 0302.1 | AC-1580690 | 0607 | DR-1916419 | 0601.3 |
| AC-1501207 | 0607 | AC-1580836 | 0607 | DR-1916541 | 0601.3 |
| AC-1501244 | 0607 | AC-1580890 | 0607 | DR-1916542 | 0601.3 |
| AC-1501463 | 0607 | AC-1580891 | 0607 | DR-1916542 | 0601.3 |
| AC-1501476 | 0607 | AC-1580892 | 0607 | DR-1916642 | 0601.3 |
| AC-1507429 | 0607 | AC-1581351 | 2208.1 | DR-1916643 | 0601.3 |
| AC-1507430 | 0607 | AC-1581436 | 2208.1 | DR-1916646 | 0601.3 |
| AC-1507492 | 0610 | AC-1581449 | 2208.1 | DR-1916773 | 0601.3 |
| AC-1507502 | 0607 | AC-1582076 | 0607 | DR-1917894 | 0601.3 |
| AC-1507680 | 0607 | AC-1582077 | 0607 | DR-1917993 | 0601.3 |
| AC-1507975 | 0607 | AC-1582314 | 0607 | DR-1918043 | 0601.3 |
| AC-1507980 | 0610 | AC-1582371 | 0607 | DR-1919234 | 0601.3 |
| AC-1508003 | 0607 | AC-1582372 | 0607 | DR-1921747 | 0601.3 |
| AC-1512422 | 0607 | AC-1582890 | 0607 | DR-1921755 | 0601.3 |
| AC-1512423 | 0610 | TI-S159-1864 | 0605 | DR-1921760 | 0601.3 |
| AC-1512669 | 0607 | UCI-160334-1 | 0607 | DR-1921761 | 0601.3 |
| AC-1512676 | 0607 | UCI-160334-9 | 0607 | DR-1921762 | 0601.3 |
| AC-1516860 | 0607 | TD-1729-S227 | 1201 | DR-1921764 | 0601.3 |
| AC-1517561 | 0607 | AXS-1819SV18/2 | 0609.2 | DR-1921772 | 0601.3 |
| AC-1517756 | 0610 | SP-18-453-10 | 2208.1 | DR-1921773 | 0601.3 |
| AC-1517871 | 0607 | DR-1903433 | 0607 | DR-1922304 | 0601.3 |
| AC-1521288 | 0302.1 | DR-1904514 | 0601.3 | DR-1997856 | 0607 |
| AC-1521906 | 0302.1 | DR-1904516 | 0601.3 | SP-200121-1 | 0900 |
| AC-1521907 | 0302.1 | DR-1906927 | 0601.3 | SP-200122-1 | 0900 |
| AC-1521908 | 0302.1 | DR-1913360 | 0607 | SP-200122-2 | 0900 |
| AC-1521909 | 0302.1 | DR-1913678 | 0601.3 | SP-22-381-19 | 0802.5 |
| AC-1521953 | 0302.1 | DR-1914906 | 0601.3 | 42-C-16600 | 2201 |
| AC-1522023 | 0302.1 | DR-1915853 | 0601.3 | 5160323 | 1204.1 |
| AC-1523043 | 0302.1 | DR-1916007 | 0601.3 | 5167516 | 0802.7 |
| AC-1523120 | 0302.1 | DR-1916106 | 0601.3 | 5175255 | 1401 |

ORDNANCE AND MANUFACTURERS' PART NUMBER INDEX—Continued

| PART NO. | SUBGROUP | PART NO. | SUBGROUP | PART NO. | SUBGROUP |
|------------|----------|----------------|----------|-----------------|----------|
| 5196397 | {1005.5 | AC-5592920 | 0302.1 | 7032623 | 0704 |
| | 1105.5 | AC-5592921 | 0302.1 | 7032624 | 0704 |
| 5214539 | {0603 | AC-5593181 | 0302.1 | 7032625 | 1204.5 |
| | 1204.1 | AC-5593764 | 0302.1 | 7032626 | 1006 |
| 5214776 | 0804 | AC-5594069 | 0302.1 | 7032628 | 1004 |
| 5214784 | 0804 | AC-5594260 | 0302.1 | 7032629 | 1101 |
| 5229645 | 2202 | 5701238 | 0601.3 | 7032630 | 1102 |
| 5232404 | 1311 | GL-5932467 | 0609.1 | 7032631 | 1102 |
| 5232405 | 1311 | GL-5933064 | 0609.1 | 7032632 | 1102 |
| 5246557 | 0202 | IL-5935713 | 0609.1 | 7032633 | 1102 |
| 5246558 | 0202 | GL-5935713 | 0609.1 | 7032634 | 1102 |
| 5261672 | 0302.1 | GL-5937374 | 0609.1 | | {0802.5 |
| 5262210 | 0501 | GL-5938368 | 0609.1 | 7032635 | 0802.7 |
| 5276883 | 0702.1 | IL-5939695 | 0609.1 | | 1002 |
| 5291787 | 0304.5 | GL-5939695 | 0609.1 | | 1102 |
| PC-5292274 | 0613.1 | GL-5939696 | 0609.1 | 7036380 | 0802.7 |
| PC-5292276 | 0617 | IL-5939697 | 0609.1 | 7036567 | 1401 |
| PC-5292376 | 0612 | GL-5939697 | 0609.1 | 7036575 | 0304.1 |
| PC-5293257 | 0605 | IL-5939700 | 0609.1 | 7036578 | 0106.6 |
| 5294507 | 0609.1 | GL-5939700 | 0609.1 | 7036584 | 1401 |
| 5304050 | 1202 | IL-5939701 | 0609.1 | 7036585 | 1401 |
| 5307283 | 0604.1 | GL-5939701 | 0609.1 | 7036587 | 1401 |
| 5307289 | 0900 | GL-5939703 | 0609.1 | 7036588 | 1401 |
| 5307299 | 0900 | GL-5939705 | 0609.1 | 7039934 | 0106.2 |
| 5308275 | 0603 | IL-5939708 | 0609.1 | 7044253 | 1503 |
| 5308280 | 0106.2 | GL-5939708 | 0609.1 | 7047970 | 0304.5 |
| 5308281 | 0106.2 | GL-5939709 | 0609.1 | 7047998 | {0304.5 |
| 5308307 | 0603 | IL-5939710 | 0609.1 | | 0613.1 |
| 5322952 | 1401 | GL-5939710 | 0609.1 | 7048736 | 0401 |
| 5327338 | 2202 | IL-5939713 | 0609.1 | 7056639 | 0612 |
| 5336400 | 0304.5 | GL-5939713 | 0609.1 | | {0609.1 |
| 5346760 | 0603 | GL-5939715 | 0609.1 | 7056708 | 0613.1 |
| 5346762 | 0603 | IL-5939716 | 0609.1 | | 0617 |
| 5346767 | 0604.1 | GL-5939716 | 0609.1 | 7056715 | 0613.1 |
| 5346768 | 0604.1 | IL-5939719 | 0609.1 | 7058965 | 2202 |
| 5346774 | 0604.1 | GL-5939719 | 0609.1 | 7065900 | 0704 |
| 5346775 | 0604.1 | IL-5939730 | 0609.1 | 7073209 | 1503 |
| 5346784 | 0604.1 | GL-5939730 | 0609.1 | 7073213 | 1503 |
| 5381088 | 0607 | GL-5939750 | 0607 | 7099460 | 2202 |
| AC-5569469 | 0605 | AC-5939764 | 0607 | TD-TI-722-8-333 | 1201 |
| AC-5590046 | 0302.1 | GL-5939765 | 0607 | 7320642 | 0609.1 |
| AC-5590460 | 0302.1 | GL-5939768 | 0607 | 7320658 | 0609.1 |
| AC-5590533 | 0302.1 | GL-5939781 | 0609.1 | 7324058 | 0301 |
| AC-5591830 | 0302.1 | GL-5939783 | 0609.1 | 7324060 | 0301 |
| AC-5591860 | 0302.1 | 6210568 | 0609.1 | 7324833 | 0612 |
| AC-5592251 | 0302.1 | 6245928 | 0106.2 | 7324835 | 0312 |
| AC-5592291 | 0302.1 | SP-6-73-1117 | 1004 | 7324840 | {0103 |
| AC-5592295 | 0302.1 | 7000997 | 2202 | | 0104.1 |
| AC-5592300 | 0302.1 | 7001411 | 1202 | 7324841 | 0201 |
| AC-5592332 | 0302.1 | 7001905 | 0302.1 | 7324918 | 1201 |
| AC-5592406 | 0302.1 | 7001906 | 0302.1 | 7326118 | 0202 |
| AC-5592409 | 0302.1 | 7010695 | 0302.1 | 7327479 | 0304.1 |
| AC-5592835 | 0302.1 | 7010699 | 0302.1 | 7328291 | 1311 |
| AC-5592836 | 0302.1 | 7016403 | 0302.1 | 7328292 | 1311 |
| AC-5592839 | 0302.1 | UTS-TO70D17775 | 0304.1 | 7328293 | 1311 |
| AC-5592893 | 0302.1 | 7032605 | 0304.5 | 7328294 | 1311 |
| AC-5592898 | 0302.1 | 7032606 | 1104.1 | 7328371 | 1311 |
| AC-5592899 | 0302.1 | 7032607 | 0304.5 | 7329375 | 1311 |
| | | | | 7328376 | 1311 |

ORDNANCE AND MANUFACTURERS' PART NUMBER INDEX—Continued

| PART NO. | SUBGROUP | PART NO. | SUBGROUP | PART NO. | SUBGROUP |
|----------|----------|----------|----------|----------|----------|
| 7329277 | 0104.1 | 7353508 | 0609.1 | 7371195 | {0613.1 |
| 7329386 | 0604.1 | 7353590 | 0609.1 | | }2202 |
| 7330714 | 0104.1 | 7355736 | 0601.3 | 7371204 | 0802.7 |
| 7340237 | 1206 | 7355830 | 2208.1 | 7371210 | 0801 |
| 7343032 | 1604.1 | 7355938 | 0617 | 7371212 | 0802.5 |
| 7343086 | 0613.1 | 7358569 | 0604.1 | 7371213 | 0802.3 |
| 7343368 | 0301 | 7358618 | 0607 | 7371226 | 0102.1 |
| 7346940 | 0612 | 7358619 | 0607 | 7371227 | 0102.2 |
| | {0612 | 7358620 | 0607 | 7371229 | 0102.2 |
| 7346945 | {0613.1 | 7358621 | 0607 | 7371231 | 0103 |
| | {2208.1 | 7358623 | 0607 | 7371235 | 0105.1 |
| 7346969 | 0604.1 | 7358626 | 0607 | 7371237 | 0105.1 |
| 7347355 | 0604.1 | 7361994 | {0312 | 7371238 | 0105.1 |
| 7347547 | 0604.1 | | }2002.5 | 7371258 | 0105.2 |
| 7347560 | 0602 | 7362105 | 0504 | 7371264 | 0106.6 |
| 7347568 | 0603 | 7362371 | 1204.1 | 7371267 | 0106.6 |
| 7347571 | 0603 | 7367859 | 1401 | 7371268 | 0106.1 |
| 7347572 | 0603 | 7368260 | 0202 | 7371270 | 0106.1 |
| 7347573 | 0601.1 | 7368267 | 0106.5 | 7371271 | 0106.1 |
| 7347733 | 1006 | 7368702 | 0607 | 7371272 | 0106.5 |
| 7348525 | 2201 | 7369850 | 0801 | 7371275 | 0106.1 |
| 7348567 | {1804 | 7369880 | 0501 | 7371278 | 0106.6 |
| | {1805 | 7369881 | 0106.2 | 7371279 | 0106.1 |
| 7348568 | 0304.5 | 7369888 | 0603 | 7371281 | 0102.2 |
| 7348571 | 0503 | 7369889 | 0603 | 7371283 | 0106.6 |
| 7348574 | 0611 | 7369951 | 2201 | 7371286 | 0106.5 |
| 7348578 | 0604.1 | 7371009 | 1204.5 | 7371311 | 0615 |
| 7348602 | 1001 | 7371030 | 1401 | 7371337 | 0202 |
| 7348603 | 1002 | 7371035 | 0802.7 | 7371338 | 0202 |
| 7348604 | {1002 | 7371037 | {0800 | 7371339 | 0202 |
| | {1102 | | }1501 | 7371340 | 0202 |
| 7348605 | 1004 | 7371047 | 0401 | 7371342 | 0202 |
| 7348609 | 1204.3 | 7371055 | {1601.1 | 7371363 | 0202 |
| 7348610 | 1204.3 | | }1601.3 | 7371364 | 0202 |
| 7348611 | 1201 | 7371056 | 1501 | 7371366 | 0202 |
| 7348759 | 1006 | 7371061 | {1601.1 | 7371368 | 0201 |
| 7348762 | 1006 | | }1601.3 | 7371371 | 0802.5 |
| 7348763 | 1006 | 7371090 | {1601.1 | 7371376 | 0102.1 |
| 7348764 | 1006 | | }1601.3 | 7371383 | 0504 |
| 7348765 | 1006 | 7371099 | 0802.7 | 7371385 | 0504 |
| 7348766 | 1006 | 7371102 | 1002 | 7371390 | 0401 |
| 7348767 | 1006 | 7371103 | 1001 | 7371454 | 0312 |
| 7348768 | 1006 | 7371105 | 1004 | 7371493 | 0102.2 |
| 7348852 | 1204.3 | 7371106 | 1311 | 7371503 | 0102.2 |
| 7348949 | 0602 | 7371108 | 1004 | 7371504 | 0102.2 |
| 7350113 | 0702.3 | 7371110 | 1006 | 7371759 | 0800 |
| 7351052 | 0704 | 7371112 | 1204.3 | 7372262 | 2202 |
| 7351133 | 0604.1 | 7371144 | 0104.1 | 7372318 | 1204.1 |
| 7351313 | 1104.1 | 7371145 | 0104.1 | 7372342 | 1204.1 |
| 7351314 | 1805 | 7371146 | 0104.1 | 7372343 | 1204.5 |
| 7351315 | 0309 | 7371147 | 0104.1 | 7372447 | 0704 |
| 7351316 | 0309 | 7371159 | 0105.5 | 7372448 | 0704 |
| 7351376 | 1401 | 7371160 | 0102.1 | 7372456 | 0704 |
| 7351395 | 0202 | 7371161 | 0102.1 | 7372500 | 0301 |
| 7351403 | 1006 | 7371188 | {0601.1 | 7372502 | 0301 |
| 7351404 | 1006 | | }0601.3 | 7372506 | 1501 |
| 7351413 | 0105.3 | 7371193 | 0312 | 7372507 | 1501 |
| 7351892 | 0106.6 | 7371194 | 0312 | 7372511 | 0301 |

ORDNANCE AND MANUFACTURERS' PART NUMBER INDEX—Continued

| PART NO. | SUBGROUP | PART NO. | SUBGROUP | PART NO. | SUBGROUP |
|-----------------|-----------------|-----------------|-----------------|-----------------|-----------------|
| 7372512 | 0301 | 7372807 | 0504 | 7372865 | 1006 |
| 7372513 | 0301 | 7372808 | 0503 | 7372866 | 1006 |
| 7372514 | 0301 | 7372809 | 0504 | 7372867 | 1006 |
| 7372517 | 0301 | 7372810 | 0504 | | {0802.5 |
| 7372518 | 0301 | 7372814 | 0504 | 7372868 | {0802.7 |
| 7372519 | 0301 | 7372816 | 0505 | | {1102 |
| 7372520 | 0301 | 7372818 | 2101 | 7372869 | 1006 |
| 7372521 | 0301 | 7372819 | 2101 | 7372870 | 1006 |
| 7372522 | 0301 | 7372820 | 2101 | 7372872 | 1006 |
| 7372525 | 0301 | 7372822 | 0202 | 7372873 | 0104.1 |
| 7372527 | 0301 | 7372823 | 0202 | 7372874 | 0104.1 |
| 7372528 | 0301 | 7372826 | 0202 | 7372875 | 0104.1 |
| 7372529 | 0301 | 7372827 | {0202 | 7372876 | 0104.1 |
| 7372530 | 0301 | | {1206 | 7372877 | 0701 |
| 7372531 | 0301 | 7372832 | 0106.6 | 7372878 | 0800 |
| 7372533 | 0301 | 7372833 | 1204.5 | | {0701 |
| 7372534 | 0301 | 7372834 | 1204.5 | 7372879 | {0801 |
| 7372536 | 0301 | 7372835 | 1204.5 | | {1004 |
| 7372537 | 0301 | 7372836 | 1204.5 | | {0609.2 |
| 7372538 | 0301 | 7372837 | 1204.5 | 7372885 | 1804 |
| 7372539 | 0301 | 7372838 | 1204.3 | | {1806 |
| 7372541 | 0301 | 7372839 | 1204.5 | | {1808 |
| 7372542 | 0301 | 7372840 | 1206 | 7372886 | {1701 |
| 7372544 | 0100.2 | 7372842 | 1001 | | {2101 |
| 7372545 | 0100.2 | 7372843 | {1002 | 7372889 | 2201 |
| 7372551 | 0100.2 | | {1102 | 7372890 | 2201 |
| 7372554 | 0304.5 | 7372844 | {1002 | 7372891 | 2201 |
| 7372557 | 0106.6 | | {1102 | 7372898 | 2201 |
| 7372558 | 0102.1 | 7372845 | {1002 | 7373108 | 1006 |
| 7372559 | 0102.1 | | {1102 | 7373111 | 1401 |
| 7372560 | 0102.1 | 7372846 | {1002 | 7373112 | 0804 |
| 7372564 | 0102.2 | | {1102 | 7373115 | 0802.7 |
| 7372565 | 0102.2 | 7372847 | {1002 | 7373116 | 0804 |
| 7372566 | 0102.2 | | {1102 | 7373117 | 0804 |
| 7372567 | 0102.2 | 7372848 | {1002 | 7373118 | 0804 |
| 7372568 | 0102.2 | | {1102 | 7373119 | 0804 |
| 7372569 | 0102.2 | 7372849 | {1002 | 7373121 | 1002 |
| 7372570 | 0102.2 | | {1102 | 7373146 | 1002 |
| 7372571 | 0102.2 | 7372850 | {1002 | 7373148 | 1004 |
| 7372572 | 0102.2 | | {1102 | 7373156 | 0802.5 |
| 7372573 | 0102.2 | 7372851 | {1002 | 7373157 | {0802.5 |
| 7372574 | 0102.2 | | {1102 | | {0802.7 |
| 7372575 | 0102.2 | 7372852 | {1002 | 7373158 | 0802.7 |
| 7372576 | 0105.5 | | {1102 | 7373159 | 0802.7 |
| 7372578 | 0105.5 | 7372853 | {1002 | 7373160 | 0802.7 |
| 7372579 | 0105.5 | | {1102 | 7373162 | 0801 |
| 7372585 | 0105.2 | | {1102 | 7373165 | 0802.5 |
| 7372586 | 0106.1 | 7372854 | 1002 | 7373166 | 0802.7 |
| 7372587 | 0106.1 | 7372855 | {1002 | 7373185 | 0802.5 |
| 7372661 | 0201 | | {1102 | 7373188 | 1004 |
| 7372667 | 0702.5 | 7372856 | 1002 | 7373350 | 0601.3 |
| 7372670 | 1806 | 7372857 | 1002 | 7373354 | 1204.1 |
| 7372678 | 1101 | 7372858 | {1002 | 7374746 | 0601.1 |
| 7372679 | 1102 | | {1102 | 7374748 | 0601.1 |
| 7372727 | 0607 | 7372859 | 1002 | 7374749 | 0601.1 |
| 7372738 | 0607 | 7372860 | 1002 | 7374750 | 0601.1 |
| 7372752 | 0304.5 | 7372863 | {1002 | 7374822 | 0602 |
| 7372806 | 0504 | | {1102 | 7374823 | 0602 |
| | | 7372864 | 1006 | | |

ORDNANCE AND MANUFACTURERS' PART NUMBER INDEX—Continued

| PART NO. | SUBGROUP | PART NO. | SUBGROUP | PART NO. | SUBGROUP |
|----------|----------|----------|----------|----------|----------|
| 7374825 | 0602 | 7374978 | 0704 | 7375081 | 0800 |
| 7374851 | 0601.1 | 7374979 | 0704 | 7375082 | 0800 |
| 7374852 | 0601.1 | 7374980 | 0704 | 7375110 | 0604.1 |
| 7374853 | 0601.1 | 7374983 | 1104.1 | 7375112 | 0312 |
| 7374854 | 0601.1 | 7374984 | 1104.1 | 7375114 | 0312 |
| 7374855 | 0601.1 | 7374985 | 1104.1 | 7375128 | 0304.5 |
| 7374856 | 0601.1 | 7374986 | 1104.1 | 7375129 | 0312 |
| 7374857 | 0601.1 | 7374987 | 1104.1 | 7375131 | 0802.1 |
| 7374858 | 0601.1 | 7374988 | 1104.1 | 7375132 | 0802.1 |
| 7374859 | 0601.1 | 7374990 | 0802.5 | 7375133 | 0802.3 |
| 7374860 | 0601.1 | 7374991 | 0702.3 | 7375134 | 0802.3 |
| 7374861 | 0601.1 | 7374992 | 0702.3 | 7375135 | 0802.3 |
| 7374862 | 0601.1 | 7374993 | 0702.3 | 7375136 | 1104.1 |
| 7374863 | 0601.1 | 7374994 | 0702.3 | 7375137 | 1311 |
| 7374865 | 0601.3 | 7374995 | 0702.3 | 7375138 | 1104.1 |
| 7374866 | 0601.3 | 7374996 | 0702.3 | 7375139 | 1311 |
| 7374878 | 0604.1 | 7374998 | 0702.3 | 7375142 | 1311 |
| 7374881 | 0604.1 | 7374999 | 0702.3 | 7375143 | 1311 |
| 7374882 | 0604.1 | 7375000 | 1601.3 | 7375144 | 1311 |
| | 0605 | 7375001 | 1601.3 | 7375146 | 0610 |
| 7374885 | 0604.1 | 7375005 | 1601.3 | 7375153 | 2002.5 |
| 7374886 | 0601.1 | 7375006 | 1601.1 | 7375155 | 1401 |
| 7374887 | 0604.1 | | 1601.3 | 7375158 | 1805 |
| 7374888 | 0604.1 | 7375007 | 1806 | 7375163 | 1808 |
| 7374893 | 0604.1 | 7375008 | 1806 | 7375166 | 1808 |
| 7374894 | 0604.1 | 7375012 | 0306 | 7375169 | 1808 |
| 7374895 | 0604.1 | 7375020 | 0306 | 7375170 | 1805 |
| 7374917 | 0602 | 7375021 | 0505 | 7375174 | 0601.1 |
| 7374918 | 0602 | 7375022 | 0609.1 | | 0601.3 |
| 7374919 | 0602 | 7375023 | 0609.1 | 7375175 | 0601.1 |
| 7374920 | 0602 | 7375024 | 0609.1 | | 0601.3 |
| 7374921 | 0602 | 7375028 | 0102.1 | 7375176 | 1204.1 |
| 7374922 | 0602 | 7375030 | 0501 | 7375177 | 1401 |
| 7374923 | 0602 | 7375032 | 0105.1 | 7375178 | 1401 |
| 7374924 | 0602 | 7375033 | 0105.1 | 7375179 | 1401 |
| 7374925 | 0602 | 7375034 | 0105.1 | 7375180 | 1401 |
| 7374930 | 0603 | 7375035 | 0105.1 | 7375181 | 1401 |
| 7374938 | 0603 | 7375036 | 0306 | 7375182 | 1401 |
| 7374940 | 0603 | 7375045 | 1004 | 7375183 | 1401 |
| 7374943 | 0602 | 7375048 | 1004 | 7375185 | 1401 |
| 7374944 | 0602 | 7375049 | 1004 | 7375189 | 2202 |
| 7374945 | 0602 | 7375051 | 0801 | 7375190 | 2202 |
| 7374960 | 0602 | 7375052 | 0801 | 7375192 | 1102 |
| 7374961 | 0602 | 7375053 | 0801 | 7375195 | 1102 |
| 7374964 | 0602 | 7375056 | 0106.2 | 7375197 | 1102 |
| 7374965 | 0602 | 7375057 | 0106.2 | 7375301 | 0603 |
| 7374966 | 0804 | 7375058 | 0106.2 | 7375312 | 1804 |
| 7374967 | 0804 | 7375059 | 0106.2 | 7375324 | 2201 |
| 7374968 | 0804 | 7375060 | 0106.2 | 7375328 | 0601.1 |
| 7374969 | 0704 | 7375063 | 0304.5 | 7375329 | 0601.1 |
| 7374970 | 0704 | 7375064 | 0312 | 7375330 | 0601.1 |
| 7374971 | 0704 | 7375065 | 0202 | 7375336 | 1401 |
| 7374972 | 0704 | | 1206 | 7375337 | 1401 |
| 7374973 | 0704 | 7375071 | 0601.1 | 7375339 | 1401 |
| 7374974 | 0704 | | 0601.3 | 7375341 | 1401 |
| 7374975 | 0704 | 7375075 | 0401 | 7375347 | 1401 |
| 7374976 | 0704 | 7375076 | 0401 | 7375348 | 1401 |
| 7374977 | 0704 | 7375077 | 0401 | 7375349 | 1401 |

ORDNANCE AND MANUFACTURERS' PART NUMBER INDEX—Continued

| PART NO. | SUBGROUP | PART NO. | SUBGROUP | PART NO. | SUBGROUP |
|-----------------|-----------------|-----------------|-----------------|-----------------|-----------------|
| 7375350 | 1808 | 7410838 | 1503 | 7411971 | 2002.1 |
| 7375351 | 1808 | 7411069 | 1204.1 | 7411972 | 2002.1 |
| 7375353 | 1808 | 7411250 | 0504 | 7411973 | 2002.5 |
| 7375354 | 1808 | 7411646 | 2001.3 | 7411974 | 2002.5 |
| 7375355 | 1808 | 7411677 | 2001.3 | 7411975 | 2002.5 |
| 7375357 | 0602 | 7411681 | 2001.3 | 7411976 | 2002.5 |
| 7375358 | 1808 | 7411685 | 2001.3 | 7411977 | 2002.5 |
| 7375371 | {0602 | 7411687 | 2001.3 | 7411979 | 2002.5 |
| | {0604.1 | 7411690 | {2001.3 | 7411980 | 2002.5 |
| 7375372 | 0604.1 | | {2002.1 | 7411981 | 2002.5 |
| 7375373 | 0604.1 | 7411799 | 2001.1 | 7411982 | 2002.5 |
| 7375376 | 0604.1 | 7411800 | 2001.1 | 7411983 | 2002.5 |
| 7375377 | 0604.1 | 7411801 | 2001.1 | 7412179 | 1202 |
| 7375378 | 0604.1 | 7411802 | 2001.1 | 7412437 | 0601.1 |
| 7375381 | 0302.1 | 7411803 | 2001.1 | 7412438 | 0601.1 |
| 7375382 | 0302.1 | 7411804 | 2001.1 | 7412442 | 0611 |
| 7375383 | 0302.1 | 7411805 | 2001.1 | 7412445 | 1401 |
| 7375385 | 0302.1 | 7411920 | 2001.1 | 7412446 | 1401 |
| 7375388 | {0601.1 | 7411921 | 2001.1 | 7412573 | 0612 |
| | {0601.3 | 7411922 | 2001.1 | 7412576 | 1401 |
| 7375389 | {0601.1 | 7411923 | 2001.1 | 7412577 | 1401 |
| | {0601.3 | 7411924 | 2001.1 | 7412579 | 1401 |
| 7375392 | 0312 | 7411925 | 2001.1 | 7412580 | 1401 |
| 7375399 | 1808 | 7411926 | 2001.1 | 7412583 | 2210 |
| 7375440 | 1204.1 | 7411927 | 2001.1 | 7412641 | 0607 |
| 7375694 | 0609.1 | 7411930 | 2001.1 | 7412643 | 0613.1 |
| 7375797 | 0202 | 7411931 | 2001.1 | 7412783 | 0609.2 |
| 7376248 | 0106.5 | 7411932 | 2001.1 | 7412959 | 0301 |
| 7376393 | 0604.1 | 7411933 | 2001.1 | 7412960 | 0604.1 |
| 7376904 | 0106.6 | 7411934 | 2001.1 | 7413199 | 0302.1 |
| 7376905 | 1806 | 7411935 | 2001.1 | 7413226 | 0601.3 |
| 7376907 | 0106.1 | 7411936 | 2001.1 | 7413315 | 0601.3 |
| 7378054 | 0301 | 7411937 | 2001.1 | 7413317 | 0601.3 |
| 7378081 | 0301 | 7411938 | 2001.1 | 7413318 | 0601.3 |
| 7378099 | 0301 | 7411939 | 2001.1 | 7413319 | 0601.3 |
| 7384388 | 0607 | 7411940 | {2001.1 | 7416462 | 1401 |
| 7384389 | 0607 | | {2002.1 | 7416478 | 0302.1 |
| 7384390 | 0607 | 7411941 | 2001.1 | 7416485 | 1006 |
| 7384392 | 0607 | 7411942 | 2001.1 | 7416486 | 1006 |
| 7385244 | 0607 | 7411943 | 2001.1 | 7416495 | 0302.1 |
| 7385245 | 0607 | 7411944 | 2001.1 | 7416521 | 0608 |
| 7387807 | 1311 | 7411945 | 2001.1 | 7416524 | 1204.1 |
| 7388074 | 0106.6 | 7411950 | 2001.3 | 7417607 | 1204.1 |
| 7388319 | {0601.1 | 7411953 | 2001.3 | 7418111 | 0104.1 |
| | {0601.3 | 7411954 | 2001.5 | 7418112 | 0104.1 |
| 7388377 | 0601.3 | 7411955 | 2001.5 | 7418113 | 0104.1 |
| 7388813 | 0608 | 7411956 | 2001.5 | 7418114 | 0104.1 |
| 7389566 | 0610 | 7411957 | 2001.5 | 7418115 | 0104.1 |
| 7389567 | 0607 | 7411958 | 2001.5 | 7418140 | 1204.1 |
| 7389881 | 2208.1 | 7411959 | 2001.5 | 7418146 | 1204.5 |
| 7391017 | 0601.3 | 7411961 | 2002.1 | 7418147 | 1804 |
| 7391018 | 0601.3 | 7411962 | 2002.1 | 7418148 | 1804 |
| 7409316 | 1204.1 | 7411963 | 2002.1 | 7418343 | 0609.1 |
| 7409702 | 2208.1 | 7411964 | 2002.1 | 7418660 | 1812 |
| 7410270 | 0302.1 | 7411965 | 2002.1 | 7418835 | 0607 |
| 7410836 | {0106.5 | 7411966 | 2002.1 | 7520991 | 1004 |
| | {0304.5 | 7411967 | 2002.1 | 7521218 | 0102.2 |
| 7410837 | 1503 | 7411970 | 2002.1 | 7524309 | 0602 |

ORDNANCE AND MANUFACTURERS' PART NUMBER INDEX—Continued

| PART NO. | SUBGROUP | PART NO. | SUBGROUP | PART NO. | SUBGROUP |
|----------|----------|----------|----------|----------|----------|
| 7524312 | 1503 | 7526596 | 0607 | 7696491 | {0804 |
| 7524313 | 1503 | 7526600 | 0607 | | }2002.5 |
| 7524314 | 1503 | 7526601 | 0607 | 7696494 | 0802.5 |
| 7524315 | 1503 | 7526940 | 0605 | 7696512 | 1002 |
| 7524316 | 1503 | 7526949 | {0605 | 7696518 | 1004 |
| | {0607 | | }1201 | 7696520 | 1311 |
| | {0609.1 | 7526951 | 0605 | 7696521 | 1311 |
| 7524649 | {0609.2 | 7526961 | 0605 | 7696523 | 1004 |
| | {0611 | 7528187 | 0605 | 7696526 | 1004 |
| | {0613.1 | 7528193 | 0605 | 7697417 | 2201 |
| | {0617 | 7528197 | 0605 | 7697418 | 2201 |
| 7524913 | {0607 | 7528200 | 0605 | 7697419 | 0702.5 |
| | {0609.2 | 7529093 | 0106.2 | 7697421 | 0702.5 |
| 7524915 | 0613.1 | 7529242 | 0609.1 | 7697422 | 0702.5 |
| 7524916 | 0613.1 | 7529480 | 0607 | 7697423 | 0702.5 |
| 7525365 | 0609.1 | 7538146 | 0609.1 | 7697424 | 0702.5 |
| 7525934 | 0613.1 | 7538582 | 0609.1 | 7697425 | 0702.5 |
| 7525935 | 0609.1 | 7538747 | 0601.3 | 7697427 | 0702.5 |
| 7525936 | 0609.1 | 7538749 | 0601.3 | 7697428 | 0702.5 |
| 7525937 | 0609.1 | 7538750 | 0601.3 | 7697429 | 0702.5 |
| 7525938 | 0609.1 | 7538751 | 0601.3 | 7697436 | 1504 |
| 7525939 | 0609.1 | 7538753 | 0601.3 | 7697439 | 1504 |
| 7525940 | 0609.1 | 7538754 | 0601.3 | | {1703 |
| 7525998 | 0609.1 | 7538756 | 0601.3 | 7697440 | }1804 |
| 7525999 | 0609.1 | 7538757 | 0601.3 | | }2201 |
| 7526000 | 0609.1 | 7538759 | 0601.3 | 7697441 | 1504 |
| 7526001 | 0609.1 | 7538760 | 0601.3 | 7697446 | {1803.1 |
| 7526002 | 0609.1 | 7538761 | 0601.3 | | }2101 |
| 7526003 | 0609.1 | 7538762 | 0601.3 | 7697447 | 1803.1 |
| 7526004 | 0609.1 | 7538763 | 0601.3 | 7697452 | 1206 |
| 7526005 | 0609.1 | 7538765 | 0601.3 | 7697453 | 1206 |
| 7526007 | 0609.1 | 7538767 | 0601.3 | 7697454 | {0202 |
| 7526008 | 0609.1 | 7538777 | 0601.3 | | }1206 |
| 7526009 | 0609.1 | 7538783 | 0601.3 | 7697459 | 1204.3 |
| 7526010 | 0609.1 | 7538784 | 0601.3 | 7697460 | 1204.3 |
| 7526011 | 0609.1 | 7538785 | 0601.3 | 7697461 | 1204.3 |
| 7526012 | 0609.1 | 7538786 | 0601.3 | 7697462 | 1204.3 |
| 7526013 | 0609.1 | 7538787 | 0601.3 | 7697463 | 1202 |
| 7526014 | 0609.1 | 7539125 | 0302.1 | 7697464 | 1202 |
| 7526015 | 0609.1 | 7539310 | 1204.1 | 7697465 | 1204.1 |
| 7526016 | 0609.1 | 7539516 | 0607 | 7697466 | 1206 |
| 7526017 | 0609.1 | 7539517 | 0607 | 7697467 | 0802.7 |
| 7526018 | 0609.1 | 7539519 | 0607 | 7697468 | 0802.7 |
| 7526019 | 0609.1 | 7539688 | 2208.1 | 7697470 | 0804 |
| 7526020 | 0609.1 | 7539689 | 2208.1 | 7697471 | 0700 |
| 7526021 | 0609.1 | 7540093 | 1006 | 7697473 | 1204.1 |
| 7526022 | 0609.1 | 7540096 | 1006 | 7697476 | 1204.1 |
| 7526023 | 0609.1 | 7696350 | 1401 | 7697477 | 1204.1 |
| 7526025 | 0609.1 | 7696351 | 1401 | 7697478 | 1204.1 |
| 7526026 | 0609.1 | 7696352 | 1401 | 7697483 | 1703 |
| 7526027 | 0609.1 | 7696370 | 1401 | 7697487 | 1703 |
| 7526028 | 0609.1 | 7696371 | 1401 | 7697489 | 1503 |
| 7526289 | 0609.1 | 7696374 | 1401 | 7697490 | 1503 |
| 7526590 | 0607 | 7696420 | 0702.5 | 7697497 | 1804 |
| 7526591 | 0607 | 7696479 | {0802.5 | 7697499 | 1806 |
| 7526592 | 0607 | | }0802.7 | 7697501 | 1806 |
| 7526594 | 0607 | 7696481 | 0804 | 7697502 | 1806 |
| 7526595 | 0607 | 7696482 | 1004 | 7697505 | 1806 |

ORDNANCE AND MANUFACTURERS' PART NUMBER INDEX—Continued

| PART NO. | SUBGROUP | PART NO. | SUBGROUP | PART NO. | SUBGROUP |
|----------|----------|----------|----------|----------|----------|
| 7697506 | 1806 | 7697595 | 2201 | 7728854 | 0607 |
| 7697507 | 1806 | 7697596 | {1601.1 | 7728856 | 0610 |
| 7697508 | 1806 | | }1601.3 | 7729791 | 0609.1 |
| 7697509 | 1806 | 7697598 | {1601.1 | 7729792 | 0609.1 |
| 7697510 | 1806 | | }1601.3 | 7729793 | 0609.1 |
| 7697512 | 1503 | 7697600 | 1601.1 | 7729796 | 0609.1 |
| 7697513 | 1801 | 7697601 | 1601.1 | 7729797 | 0609.1 |
| 7697514 | 1801 | 7697602 | {1601.1 | 7729798 | 0609.1 |
| 7697515 | 1805 | | }1601.3 | 7729799 | 0609.1 |
| 7697519 | 1805 | 7697606 | 1002 | 7729802 | 0609.1 |
| 7697520 | 1805 | 7697608 | 0900 | 7730893 | 0613.1 |
| 7697521 | 1805 | 7697611 | 0900 | 7731428 | 0617 |
| 7697522 | 1805 | 7697613 | 0900 | 7731429 | 0617 |
| 7697523 | 1805 | 7697614 | 0505 | 7731435 | 0613.1 |
| 7697525 | 1805 | 7697855 | 1201 | 7732849 | 0609.2 |
| 7697526 | 1805 | 7697864 | 0102.1 | 7735289 | 1204.5 |
| 7697527 | 1805 | 7697870 | 1501 | 7735312 | 1204.3 |
| 7697531 | 1806 | 7698489 | 1808 | 7735833 | {1601.1 |
| 7697534 | 1806 | 7698490 | 1808 | | }1601.3 |
| 7697535 | 1806 | 7701013 | 0108 | 7735842 | 1601.1 |
| 7697536 | 1806 | 7701327 | 1801 | 7735843 | {1601.1 |
| 7697537 | 1806 | 7701328 | 1801 | | }1601.3 |
| 7697538 | 1806 | 7702465 | 0900 | 7741406 | 0105.5 |
| 7697539 | 1806 | 7702608 | 0602 | 7741407 | 0105.3 |
| 7697546 | 0702.5 | 7702645 | 0602 | 7741414 | 0105.5 |
| 7697547 | 0702.5 | 7702646 | 0602 | 7741415 | 0105.5 |
| | {1701 | 7702665 | 0602 | 7741419 | 0105.5 |
| 7697548 | 1804 | 7705721 | 0201 | 7741420 | 0105.1 |
| | 2101 | 7706790 | 0604.1 | 7741427 | 0105.5 |
| 7697550 | 2101 | 7712833 | 0609.1 | 7743569 | 0105.2 |
| 7697554 | 2210 | | {0601.1 | 7743652 | 0802.1 |
| 7697555 | 2210 | 7716562 | {0601.3 | 7743751 | 0104.2 |
| 7697561 | 2210 | | }0602 | 7743752 | 0104.2 |
| 7697562 | 2210 | 7716690 | {0601.1 | 7743818 | 0102.1 |
| 7697564 | 0702.1 | | }0601.3 | 7744319 | 0105.3 |
| 7697566 | 0702.1 | 7716895 | 0613.1 | 7744324 | 0106.1 |
| 7697567 | 0702.1 | 7717021 | 2001.1 | 7744331 | 0106.1 |
| 7697568 | 0702.1 | 7720495 | 0613.1 | 7744332 | 0106.1 |
| 7697569 | 0702.1 | 7720853 | 0613.1 | 7744333 | 0106.1 |
| 7697570 | 0702.1 | 7722333 | {0613.1 | 7744469 | 0102.1 |
| 7697571 | 0702.1 | | }0617 | 7744471 | 0104.2 |
| 7697572 | 0702.1 | 7722343 | 0613.1 | 7744472 | {0104.2 |
| 7697574 | 1501 | 7722367 | 0613.1 | | }0105.2 |
| 7697577 | 1805 | 7722368 | 0613.1 | 7744473 | 0102.1 |
| 7697578 | 1805 | 7723306 | 0613.1 | 7760396 | 2208.1 |
| 7697579 | 1805 | 7723308 | 0613.1 | 7760409 | 0607 |
| 7697581 | {1805 | 7723309 | {0613.1 | 7760412 | 0607 |
| | 1808 | | }0617 | 7760417 | 0603 |
| 7697588 | 0503 | 7723899 | 0609.1 | 7760418 | 0607 |
| | {1703 | | {0607 | 7760503 | 0609.1 |
| | 1803.1 | 7726804 | {0609.2 | 7760504 | 0609.1 |
| | 1804 | | }0613.1 | 7760505 | 0609.1 |
| 7697591 | 1806 | 7726808 | {0607 | 7760506 | 0609.1 |
| | 1808 | | }0609.2 | 7760507 | 0609.1 |
| 7697592 | {1803.1 | 7728341 | {0613.1 | | 0607 |
| | 2101 | 7728788 | 0611 | | 0609.1 |
| 7697593 | 2201 | 7728852 | 0608 | 7760598 | {0609.2 |
| 7697594 | 2201 | 7728853 | 0607 | | 0613.1 |
| | | | 0607 | | 0617 |

ORDNANCE AND MANUFACTURERS' PART NUMBER INDEX—Continued

| PART NO. | SUBGROUP | PART NO. | SUBGROUP | PART NO. | SUBGROUP |
|--------------|----------|----------|----------|----------|----------|
| 7760599 | 0609.1 | 8328066 | 0603 | 8328446 | 1501 |
| | 0609.2 | 8328067 | 0603 | 8328448 | 1503 |
| | 0611 | 8328069 | 0603 | 8328449 | 0605 |
| | 0613.1 | 8328071 | 0603 | 8328455 | 0503 |
| 7762605 | 0613.1 | 8328076 | 0604.1 | 8328456 | 0503 |
| 7762624 | 0607 | 8328125 | 0103 | 8328457 | 0503 |
| 7762642 | 0613.1 | 8328126 | 0105.1 | 8328458 | 0503 |
| | 0609.1 | 8328127 | 0201 | 8328461 | 1703 |
| 7762687 | 0613.1 | 8328129 | 0202 | 8328463 | 0101 |
| | 0617 | 8328130 | 0202 | 8328464 | 1804 |
| | 0609.1 | 8328132 | 0603 | 8328465 | 1804 |
| 7762750 | 0613.1 | 8328133 | 0603 | 8328468 | 1804 |
| | 0617 | 8328134 | 0603 | 8328469 | 1703 |
| | 0609.1 | 8328135 | 0603 | 8328470 | 1703 |
| 7762751 | 0613.1 | 8328136 | 0603 | 8328471 | 1703 |
| | 0617 | 8328139 | 0603 | 8328472 | 1703 |
| 7765214 | 0609.1 | 8328140 | 0603 | 8328474 | 0101 |
| 7954230 | 0607 | 8328141 | 0603 | 8328475 | 1501 |
| 7954231 | 0610 | 8328144 | 0603 | 8328478 | 0802.7 |
| 7954265 | 0202 | 8328252 | 0613.1 | 8328479 | 0802.7 |
| | 1206 | 8328264 | 1503 | 8328480 | 2208.1 |
| 7954266 | 1804 | 8328265 | 0201 | 8328481 | 2208.1 |
| 7954511 | 0607 | 8328310 | 0103 | 8328483 | 0103 |
| 7954878 | 0607 | 8328311 | 0103 | 8328484 | 0103 |
| 7954879 | 0607 | 8328312 | 0103 | 8328486 | 1806 |
| 7971279 | 0302.1 | 8328313 | 0103 | 8328487 | 1806 |
| 7980860 | 0604.1 | 8328371 | 1311 | 8328488 | 1806 |
| 7994148 | 2002.1 | 8328391 | 0100.2 | 8328489 | 1806 |
| 7994190 | 2001.3 | 8328393 | 0100.2 | 8328490 | 0501 |
| 7994191 | 2001.1 | 8328396 | 0100.1 | 8328491 | 0501 |
| 7994192 | 2001.1 | 8328397 | 1004 | 8328492 | 0501 |
| 7994193 | 2001.1 | 8328398 | 1004 | 8328493 | 0501 |
| 7994194 | 2001.3 | 8328405 | 0106.6 | 8328495 | 0900 |
| 7994195 | 2001.1 | 8328406 | 0106.6 | 8328496 | 0900 |
| 7994196 | 2001.3 | 8328407 | 0106.6 | 8328497 | 0900 |
| 7994197 | 2001.3 | 8328408 | 0106.6 | 8328498 | 0900 |
| 7994200 | 2001.1 | 8328409 | 0106.6 | 8328499 | 0900 |
| 7994778 | 1004 | 8328410 | 0106.6 | 8329517 | 0105.1 |
| 7994785 | 1004 | 8328412 | 1703 | 8329518 | 0105.1 |
| 7994786 | 0702.3 | 8328414 | 1002 | 8329519 | 0105.1 |
| 7994912 | 1102 | 8328417 | 1701 | 8329600 | 1601.1 |
| 7994913 | 1102 | 8328418 | 1701 | | 1601.3 |
| TRI-82812-41 | 2202 | 8328420 | 1701 | 8329601 | 1601.1 |
| 8327721 | 0601.1 | 8328421 | 1701 | 8329602 | 1601.1 |
| 8328005 | 1102 | 8328422 | 0106.2 | | 1601.3 |
| 8328043 | 0100.2 | | 1803.1 | 8329605 | 0604.1 |
| 8328046 | 0103 | 8328423 | 1804 | 8329606 | 0304.5 |
| 8328047 | 0103 | | 2201 | 8329607 | 1202 |
| 8328048 | 0103 | 8328436 | 0202 | 8329608 | 1202 |
| 8328049 | 0103 | | 1206 | 8329609 | 1202 |
| 8328056 | 0603 | 8328437 | 0202 | 8329611 | 1202 |
| 8328057 | 0603 | 8328439 | 0202 | 8329613 | 0306 |
| 8328058 | 0603 | 8328440 | 0802.5 | 8329614 | 0306 |
| 8328061 | 0603 | 8328441 | 0309 | 8329615 | 0306 |
| 8328062 | 0603 | 8328442 | 1204.3 | 8329616 | 0306 |
| 8328063 | 0603 | 8328443 | 1204.3 | 8329617 | 0306 |
| 8328064 | 0603 | 8328444 | 1204.3 | 8329618 | 0306 |
| 8328065 | 0603 | 8328445 | 1204.3 | 8329619 | 0306 |

ORDNANCE AND MANUFACTURERS' PART NUMBER INDEX—Continued

| PART NO. | SUBGROUP | PART NO. | SUBGROUP | PART NO. | SUBGROUP |
|----------|----------|----------|----------|----------|----------|
| 8329621 | 0306 | 8329694 | 0105.1 | 8329761 | 0312 |
| 8329623 | 1201 | 8329695 | 0105.1 | 8329762 | 0312 |
| 8329624 | {0304.5 | 8329696 | 0105.1 | 8329763 | 0312 |
| | 2202 | 8329697 | 0105.1 | 8329764 | 0312 |
| 8329625 | 1201 | 8329698 | 0105.3 | 8329765 | 0312 |
| 8329626 | 1201 | 8329699 | 0108 | 8329766 | 0312 |
| 8329627 | 1201 | 8329700 | 0900 | 8329767 | 0312 |
| 8329629 | 1201 | 8329701 | 0302.1 | 8329768 | 0312 |
| 8329630 | 1201 | 8329702 | 0302.1 | 8329769 | 0312 |
| 8329632 | 1201 | 8329703 | 0302.1 | 8329770 | 0312 |
| 8329633 | 1201 | 8329704 | 0302.1 | 8329771 | 0301 |
| 8329634 | 0304.5 | 8329705 | 0302.1 | 8329772 | 0301 |
| 8329636 | 0304.5 | 8329706 | 0302.1 | 8329773 | 0301 |
| 8329637 | 0304.5 | 8329707 | 0302.1 | 8329774 | 0301 |
| 8329638 | 0304.5 | 8329708 | 0302.1 | 8329775 | 0306 |
| 8329639 | 0304.5 | 8329709 | 0302.1 | 8329777 | 0306 |
| 8329640 | 0304.5 | 8329710 | 0105.2 | 8329778 | 0306 |
| 8329641 | 0304.5 | 8329711 | 0105.2 | 8329779 | 1804 |
| 8329642 | 0304.1 | 8329712 | 0105.2 | 8329781 | 0306 |
| 8329643 | 0304.1 | 8329713 | 0105.2 | 8329782 | 0306 |
| 8329644 | 0304.1 | 8329714 | 0105.2 | 8329783 | 0306 |
| 8329645 | 0304.5 | 8329715 | 0105.2 | 8329784 | 0604.1 |
| 8329646 | 0304.1 | 8329716 | 0105.2 | 8329785 | 0604.1 |
| 8329647 | 0304.1 | 8329717 | 0105.2 | 8329786 | 0604.1 |
| 8329648 | 0304.1 | 8329718 | 0105.2 | 8329787 | 0604.1 |
| 8329649 | 1601.1 | 8329719 | 0105.2 | 8329825 | 0301 |
| 8329650 | 1808 | 8329720 | 0105.2 | 8329826 | 0301 |
| 8329651 | 1804 | 8329721 | 0105.2 | 8329828 | 0301 |
| 8329652 | 1804 | 8329723 | 1401 | 8329830 | 0301 |
| 8329653 | 1804 | 8329724 | 1401 | 8329831 | 0301 |
| 8329654 | 1808 | 8329725 | 1401 | 8329832 | 0301 |
| 8329655 | 1808 | 8329726 | 1401 | 8329833 | 0301 |
| 8329656 | 1804 | 8329727 | 1401 | 8329834 | 0301 |
| 8329658 | 1804 | 8329728 | 1401 | 8329835 | 0301 |
| 8329659 | 1804 | 8329729 | 1401 | 8329836 | 0301 |
| 8329662 | 0613.1 | 8329730 | 1401 | 8329837 | 0301 |
| 8329663 | 0612 | 8329731 | 1311 | 8329850 | 1101 |
| 8329664 | 0612 | 8329732 | 1311 | 8329852 | {1002 |
| 8329665 | 0612 | 8329733 | 1805 | | 1102 |
| 8329666 | 0612 | 8329734 | 1808 | 8329853 | 0701 |
| 8329668 | 1204.1 | 8329735 | 1805 | 8329854 | 1100 |
| 8329669 | 1401 | 8329736 | 0613.1 | | {0105.1 |
| 8329674 | 0802.5 | 8329738 | 0605 | 8329873 | 0702.1 |
| 8329675 | 0101 | 8329739 | 0401 | | 0702.5 |
| 8329676 | 0101 | 8329740 | 0603 | | 0704 |
| 8329677 | 0101 | 8329741 | 1401 | 8329889 | 2002.5 |
| 8329678 | 0101 | 8329742 | 1401 | 8329966 | 0503 |
| 8329679 | 0101 | 8329743 | 1401 | 8329975 | 2101 |
| 8329680 | 0101 | 8329744 | 1401 | 8329976 | 2101 |
| 8329683 | 0106.5 | 8329746 | 1401 | 8329977 | 2101 |
| 8329684 | 0106.5 | 8329747 | 1401 | 8329978 | 1601.1 |
| 8329686 | 0610 | 8329748 | 1401 | 8329979 | 2101 |
| 8329687 | 0610 | 8329750 | 0108 | 8329982 | 1808 |
| 8329688 | 0611 | 8329751 | 0108 | 8329983 | 1808 |
| 8329689 | 0611 | 8329754 | 2201 | | {0105.2 |
| 8329690 | 0611 | 8329756 | 1804 | 8329984 | 1808 |
| 8329691 | 0105.1 | 8329759 | 0312 | | 1812 |
| 8329693 | 0105.1 | 8329760 | 0312 | 8329985 | 0613.1 |

ORDNANCE AND MANUFACTURERS' PART NUMBER INDEX--Continued

| PART NO. | SUBGROUP | PART NO. | SUBGROUP | PART NO. | SUBGROUP |
|----------|----------|----------|----------|----------|----------|
| 8329987 | 1808 | 8332063 | 0612 | 8333280 | 0610 |
| 8329988 | {1804 | 8332065 | 1804 | 8333281 | 0613.1 |
| | 1808 | 8332071 | 0100.1 | 8333282 | 0613.1 |
| 8329991 | 1808 | 8332072 | 0202 | 8333283 | 0900 |
| 8329992 | 1000 | 8332074 | 1503 | 8333284 | 1201 |
| 8329993 | 0800 | 8332076 | 2202 | 8333285 | 1601.1 |
| 8329994 | 0704 | 8332077 | {0309 | 8333286 | 1601.1 |
| 8329996 | 2202 | | 0610 | 8333287 | {1601.1 |
| 8329997 | 2202 | 8332078 | 0602 | | 1601.3 |
| 8330073 | 0105.2 | 8332080 | 0302.1 | 8333288 | 1601.3 |
| 8330124 | 0304.1 | 8332083 | 1204.1 | 8333289 | 1604.1 |
| 8330125 | 0304.1 | 8332084 | 0304.5 | 8333290 | 1604.1 |
| 8330126 | 0304.1 | 8332085 | 0106.5 | 8333291 | 1605 |
| 8330127 | 0304.1 | 8332124 | 2001.3 | 8333292 | 1605 |
| 8330128 | 0304.1 | 8332226 | 0601.1 | 8333293 | 1605 |
| 8330129 | 0304.1 | 8332277 | 0306 | 8333294 | 1605 |
| 8330225 | 0105.2 | 8332473 | 0502 | 8333295 | 1605 |
| 8330238 | 2202 | 8332474 | 1401 | 8333296 | 1605 |
| 8330239 | 0103 | 8332475 | 1401 | 8333297 | 1605 |
| 8330271 | 0106.2 | 8332476 | 1401 | 8333298 | 1605 |
| 8330272 | 0106.6 | 8332513 | 1806 | 8333299 | 1605 |
| 8330507 | 1601.1 | 8332514 | {0700 | 8333364 | 0312 |
| 8330508 | 1601.3 | | 2001.3 | 8333365 | 0312 |
| 8330509 | 1601.1 | 8332515 | 1401 | 8333378 | 1311 |
| 8330510 | 1601.1 | 8332516 | 1401 | 8333425 | 1605 |
| 8330511 | 1601.3 | 8332517 | 1401 | 8333426 | 2210 |
| 8330512 | 1604.1 | 8332518 | 0611 | 8333427 | 2210 |
| 8330513 | 1604.1 | 8332519 | 1311 | 8333428 | 2210 |
| 8330745 | 0104.2 | 8332520 | 0301 | 8333429 | 2210 |
| 8330746 | 0104.2 | 8332521 | 0302.1 | 8333722 | 0306 |
| 8330747 | 0104.2 | 8332522 | 0601.1 | 8333767 | 1601.1 |
| 8330748 | 0104.2 | 8332524 | 0610 | 8333800 | 1601.3 |
| 8330945 | 1805 | 8332529 | {1601.1 | 8344313 | 1601.3 |
| 8330946 | 0306 | | 1601.3 | 8357724 | 0605 |
| 8330947 | 0312 | 8332530 | 0106.6 | 8376209 | 0617 |
| 8330948 | {0312 | 8332534 | 0302.1 | 8376244 | 0702.3 |
| | 1201 | 8332535 | 0302.1 | 8376245 | 0702.3 |
| 8330950 | 1504 | 8332549 | 1401 | 8376246 | 0702.3 |
| 8331232 | 1601.1 | 8332550 | 1401 | 8376374 | 0607 |
| 8331234 | 1601.1 | 8332551 | 1401 | 8376375 | 2208.1 |
| 8331235 | 1601.1 | 8332552 | 1401 | 8376377 | 0607 |
| 8331236 | 1601.3 | 8332553 | 1401 | 8376378 | 0607 |
| 8331237 | 1601.3 | 8332556 | 0304.5 | 8376379 | 0607 |
| 8331238 | 1601.3 | 8332574 | 1804 | 8376380 | 0607 |
| 8331239 | 1601.3 | 8332675 | 0304.1 | 8376619 | 0607 |
| 8331246 | 0106.1 | 8332677 | 0611 | 8386439 | 2210 |
| 8331730 | 0702.5 | 8332928 | {1601.1 | 8386440 | 2210 |
| 8331732 | 0702.3 | | 1601.3 | 8387940 | {0202 |
| 8331733 | 0702.3 | 8333019 | 1601.1 | | 1206 |
| 8331793 | {0802.5 | 8333061 | 0900 | 8392985 | 1804 |
| | 0802.7 | 8333106 | 1311 | 8393045 | 0202 |
| 8331831 | 2101 | 8333138 | {1601.1 | 8393046 | 1501 |
| 8331874 | 1204.1 | | 1601.3 | 8393048 | 1401 |
| 8331932 | 0106.6 | 8333257 | 0613.1 | 8393055 | 1401 |
| 8331933 | 0306 | 8333259 | {1601.1 | 8393066 | 1701 |
| 8331954 | 1805 | | 1601.3 | 8393069 | 0612 |
| 8332058 | 1101 | 8333278 | 0401 | 8393076 | 0612 |
| 8332060 | 0503 | 8333279 | 0401 | 8393078 | 0304.5 |

ORDNANCE AND MANUFACTURERS' PART NUMBER INDEX—Continued

| PART NO. | SUBGROUP | PART NO. | SUBGROUP | PART NO. | SUBGROUP |
|----------|----------|----------|----------|----------|----------|
| 8393084 | 0104.1 | 8673521 | 1100 | 8677293 | 1501 |
| 8393090 | 0602 | 8673949 | 0702.1 | 8677294 | 1102 |
| 8393091 | 0602 | 8673952 | 0106.1 | 8677295 | 1102 |
| 8393092 | 0602 | 8673956 | 0106.1 | 8677296 | 0105.2 |
| 8393093 | 0602 | 8673965 | 0503 | 8677304 | 1204.1 |
| 8393094 | 0602 | 8673967 | 1204.1 | 8677314 | 1805 |
| 8393095 | 0602 | 8673968 | 1501 | 8677315 | 2201 |
| 8393107 | 0612 | 8673988 | 1806 | | 0612 |
| 8393111 | 1311 | 8673998 | 1800 | | 1701 |
| 8393194 | 1804 | 8673999 | 0612 | 8677317 | 1703 |
| 8393195 | 0612 | | 1804 | | 1804 |
| 8393196 | 0612 | 8676953 | 1808 | | 1805 |
| 8393197 | 0612 | | 2201 | | 1808 |
| 8393198 | 1701 | 8676956 | 1800 | 8677333 | 1401 |
| 8393199 | 0612 | | 1703 | 8677344 | 1204.5 |
| 8393202 | 0612 | | 1804 | 8677345 | 1204.5 |
| 8393203 | 1804 | 8676969 | 1805 | 8677346 | 1401 |
| 8393204 | 1804 | | 1808 | 8677394 | 0612 |
| 8393205 | 1703 | | 2101 | 8677400 | 1703 |
| 8393223 | 0612 | 8676970 | 1806 | 8677401 | 1808 |
| 8393224 | 1808 | 8676975 | 1313 | 8677402 | 1804 |
| 8393225 | 1808 | 8676979 | 1503 | 8677403 | 1804 |
| 8393226 | 1703 | 8676987 | 1401 | 8677416 | 1501 |
| 8393228 | 1804 | 8677008 | 0103 | 8677419 | 1501 |
| 8393332 | 2101 | 8677013 | 1002 | 8677420 | 1501 |
| 8672285 | 0602 | 8677015 | 0104.2 | 8677421 | 1501 |
| 8672286 | 0602 | 8677020 | 1401 | 8677426 | 1204.5 |
| 8673315 | 1311 | 8677028 | 0304.5 | 8677428 | 1501 |
| 8673316 | 1206 | 8677029 | 0104.1 | 8677429 | 1501 |
| 8673318 | 0617 | 8677030 | 0104.1 | 8677431 | 0613.1 |
| 8673345 | 1808 | 8677031 | 0104.1 | 8677432 | 0304.5 |
| 8673350 | 0601.1 | 8677035 | 1401 | 8677436 | 2210 |
| 8673354 | 0101 | 8677040 | 1501 | 8677437 | 0101 |
| 8673356 | 0304.5 | | 1504 | 8677448 | 1805 |
| 8673357 | 0304.5 | 8677053 | 0201 | 8677498 | 0105.2 |
| 8673359 | 2210 | 8677054 | 1204.5 | 8677499 | 0105.2 |
| 8673366 | 1206 | 8677058 | 0104.1 | 8677500 | 1501 |
| 8673368 | 1401 | 8677059 | 0613.1 | 8677501 | 0312 |
| 8673384 | 1501 | 8677061 | 1401 | 8677502 | 0312 |
| 8673393 | 0104.2 | 8677065 | 1503 | 8677503 | 1501 |
| 8673397 | 1206 | 8677069 | 2210 | 8677504 | 1501 |
| 8673464 | 1002 | 8677073 | 1313 | 8677505 | 1501 |
| 8673467 | 1501 | 8677074 | 1313 | 8677507 | 0309 |
| 8673471 | 0602 | 8677075 | 1313 | 8677508 | 0309 |
| 8673473 | 1204.5 | 8677076 | 1002 | 8677509 | 0802.7 |
| 8673474 | 1204.5 | 8677079 | 1006 | 8677510 | 0802.5 |
| 8673476 | 0102.1 | 8677080 | 1006 | 8677512 | 0104.1 |
| 8673477 | 1501 | 8677256 | 1806 | 8677517 | 1501 |
| 8673482 | 1206 | 8677259 | 1504 | 8677519 | 1401 |
| 8673489 | 1806 | 8677261 | 0612 | 8677520 | 0613.1 |
| 8673507 | 1501 | 8677266 | 2202 | 8677521 | 0304.5 |
| 8673512 | 1006 | 8677275 | 0202 | 8677523 | 0304.5 |
| 8673513 | 0609.1 | 8677281 | 1104.1 | 8677525 | 0309 |
| 8673515 | 1501 | 8677283 | 1501 | 8677526 | 1501 |
| 8673516 | 0900 | 8677287 | 1002 | 8677533 | 1401 |
| 8673517 | 0900 | 8677288 | 1002 | 8677534 | 1501 |
| 8673518 | 1501 | 8677289 | 1501 | 8677537 | 0105.1 |
| 8673520 | 1000 | 8677291 | 1501 | 8677538 | 0304.5 |

ORDNANCE AND MANUFACTURERS' PART NUMBER INDEX—Continued

| PART NO. | SUBGROUP | PART NO. | SUBGROUP | PART NO. | SUBGROUP | |
|----------|----------|--------------|----------|---------------------|------------------|--------|
| 8677539 | 0900 | 8677636 | 0612 | SCI-10-40813-5 | 0613.1 | |
| 8677545 | 0612 | 8677639 | 1804 | SCI-10-42222-2S | 0601.1 | |
| 8677546 | 1808 | 8677641 | 0612 | 17-T-1745-60 | {0609.1 | |
| 8677551 | 0612 | 8677644 | 0108 | | {0611 | |
| 8677552 | 1804 | 8677648 | 1501 | | {0613.1 | |
| 8677554 | 0612 | 8677649 | 1501 | SP-2-62-3-2122X | 0900 | |
| 8677557 | 1804 | 8677650 | 1501 | 44-T-5080-10 | 1204.5 | |
| 8677558 | 1804 | 8677658 | 1504 | 44-T-5080-15 | 2202 | |
| 8677559 | 1804 | 8679542 | 0105.2 | SCI-60-42613-5S | 0613.1 | |
| 8677565 | 2202 | 8679978 | 1006 | SCI-60-42622-2S | 0613.1 | |
| 8677566 | 2101 | 8680526 | 1804 | SCI-60-42622-22P | 0613.1 | |
| 8677577 | 1100 | 8680884 | 1800 | SHA-9805-20-00 | 0607 | |
| 8677578 | 1501 | 8680895 | 0312 | SCI-10-40822-54 | 0613.1 | |
| 8677579 | 1501 | 8720570 | 0302.1 | SCI-10-40828-51 | 0617 | |
| 8677588 | 1805 | BX-904616-K6 | 1202 | 15-C-2165-170 | {0611 | |
| 8677594 | 1804 | 9407716 | 0609.2 | | {0613.1 | |
| 8677596 | 0612 | 9409097 | {1806 | 15-C-2165-200 | 0613.1 | |
| 8677598 | 1703 | | | {1812 | 15-C-2165-250 | 0613.1 |
| 8677599 | 1804 | 9409098 | 1806 | 22W-1631-110 | 0804 | |
| 8677600 | 2101 | 9409102 | {1601.1 | SP-2-60-20-1519X | 0900 | |
| 8677601 | 1808 | | | {1601.3 | SP-2-60-20-1519 | 0900 |
| 8677605 | 0502 | | | {1812 | SP-2-60-20-3505X | 0900 |
| 8677606 | 1805 | | {2201 | SP-402-94622-1 | 0802.3 | |
| 8677608 | 1805 | 9409103 | 1206 | 42-C-14761-10 | 2001.1 | |
| 8677609 | 1701 | 9409106 | 1703 | 51A-1562-255 | 0612 | |
| 8677616 | 1202 | 9409107 | {0611 | TI-C57901-2600 | 0605 | |
| 8677617 | 1202 | | | {1804 | SCI-60-36028-51S | 0617 |
| 8677618 | 1204.5 | 9409110 | {0609.1 | SCI-60-36030-51S | 0617 | |
| 8677619 | 0304.5 | | | {2202 | SCI-60-36397-28 | 0617 |
| 8677620 | 0105.2 | 9409113 | 1504 | SCI-60-42628-51S | 0613.1 | |
| 8677622 | 0101 | 9409115 | 1701 | SCI-60-37005-131 | 0613.1 | |
| 8677623 | 0101 | 9409116 | 1204.1 | SCI-60-37005-221 | 0613.1 | |
| 8677625 | 0503 | WH-100-23123 | 0304.5 | SCI-60-37005-281 | {0613.1 | |
| 8677628 | 1401 | WH-103-40004 | 0304.5 | | {0617 | |
| 8677629 | 1804 | WH-103-60002 | 0106.5 | RG-TL142002-447/441 | 1401 | |
| 8677630 | 1805 | | | | | |

ORDNANCE STOCK NUMBER INDEX

This index includes one type of stock number – the SNL-prefix type (G758-8329600). These numbers are each arranged numerically by types. H-, J-, and K-group numbers are not included generally in this index because they refer to standard items which may appear in various groups or already have a common application in the supply system and are not necessarily peculiar within an index of this kind.

| STOCK NO. | SUBGROUP | STOCK NO. | SUBGROUP | STOCK NO. | SUBGROUP |
|--------------|----------|--------------|----------|--------------|----------|
| G067-0905540 | 0609.1 | | {0607 | G262-7353590 | 0609.1 |
| G067-1500270 | 0302.1 | G244-7726808 | {0609.2 | G262-7416495 | 0302.1 |
| G067-1501920 | 0302.1 | | {0613.1 | G501-5262210 | 0501 |
| G085-3004220 | 0301 | G244-7729791 | 0609.1 | G502-0180653 | 2202 |
| G085-3004900 | 0301 | G244-7729793 | 0609.1 | G502-0389787 | 2202 |
| G085-3005020 | 0301 | G244-7729796 | 0609.1 | G502-0482430 | 2202 |
| G085-5307299 | 0900 | G244-7729797 | 0609.1 | G502-5327338 | 2202 |
| G085-7735289 | 1204.5 | G244-7729802 | 0609.1 | G502-5346760 | 0603 |
| G085-7735312 | 1204.3 | | {0607 | G502-7324058 | 0301 |
| G102-0101396 | 0103 | | {0609.1 | G502-7324060 | 0301 |
| G102-5175255 | 1401 | G244-7760598 | {0609.2 | G502-7329386 | 0604.1 |
| G102-5214759 | 0302.1 | | {0613.1 | G502-7350113 | 0702.3 |
| G102-5214761 | 0302.1 | | {0617 | G502-7702665 | 0602 |
| G102-5292984 | 0302.1 | G244-7762605 | 0613.1 | G503-0169093 | 0304.1 |
| G102-5322952 | 1401 | G251-7320642 | 0609.1 | G503-0194022 | 0105.1 |
| G104-5246558 | 0202 | G251-7525938 | 0609.1 | | {0105.1 |
| G104-6184238 | 0302.1 | G251-7525939 | 0609.1 | G503-0194032 | {0702.1 |
| G116-0400060 | 0604.1 | G251-7526005 | 0609.1 | | {0702.5 |
| G136-7376248 | 0106.5 | G251-7526007 | 0609.1 | | {0704 |
| G136-7376393 | 0604.1 | G251-7526026 | 0609.1 | G503-5214776 | 0804 |
| G147-0389807 | 0302.1 | G251-7526028 | 0609.1 | G503-5214784 | 0804 |
| G160-7372262 | 2202 | G251-7722343 | 0613.1 | G503-5246557 | 0202 |
| G160-7980860 | 0604.1 | G251-7729799 | 0609.1 | G503-5261672 | 0302.1 |
| G162-1449805 | 0609.1 | G251-7762642 | 0613.1 | G503-5281457 | 0301 |
| G176-5276883 | 0702.1 | G251-7762751 | 0613.1 | G503-5293029 | 0301 |
| G179-5308280 | 0106.2 | G252-7056639 | 0612 | G503-5307289 | 0900 |
| G179-8331730 | 0702.5 | | {0607 | G503-5381088 | 0607 |
| G179-8331732 | 0702.3 | G252-7524649 | {0609.1 | G503-7036567 | 1401 |
| G179-8331733 | 0702.3 | | {0609.2 | G503-7036575 | 0304.1 |
| G184-5229645 | 2202 | | {0611 | G503-7036578 | 0106.6 |
| G200-7412573 | 0612 | G252-7525934 | {0613.1 | G503-7036584 | 1401 |
| G226-5214739 | 0302.1 | | {0617 | G503-7036585 | 1401 |
| G226-5214746 | 0302.1 | G252-7525934 | 0613.1 | G503-7036587 | 1401 |
| G244-7524913 | {0607 | | {0609.1 | G503-7036588 | 1401 |
| | {0609.2 | G256-7762687 | {0613.1 | G503-7044253 | 1503 |
| | {0601.1 | | {0617 | G503-7073209 | 1503 |
| G244-7716562 | {0601.3 | G256-7762750 | {0609.1 | G503-7073213 | 1503 |
| | {0602 | | {0613.1 | G503-7099460 | 2202 |
| G244-7716895 | 0613.1 | G256-7762751 | {0617 | G503-7324833 | 0612 |
| G244-7720495 | 0613.1 | | {0609.1 | G503-7324835 | 0312 |
| G244-7723306 | 0613.1 | G258-8376209 | {0617 | G503-7324840 | {0103 |
| G244-7723308 | 0613.1 | G260-7358618 | 0617 | | {0104.1 |
| G244-7723899 | 0609.1 | G260-7388319 | 0607 | G503-7324841 | 0201 |
| | {0607 | | {0601.1 | G503-7324918 | 1201 |
| G244-7726804 | {0609.2 | G260-7526001 | {0601.3 | G503-7326118 | 0202 |
| | {0613.1 | | {0609.1 | G503-7327479 | 0304.1 |
| | | G260-7526289 | 0609.1 | G503-7329277 | 0104.1 |
| | | G260-7765214 | 0609.1 | G503-7330714 | 0104.1 |

ORDNANCE STOCK NUMBER INDEX--Continued

| STOCK NO. | SUBGROUP | STOCK NO. | SUBGROUP | STOCK NO. | SUBGROUP |
|--------------|----------|--------------|----------|--------------|----------|
| G503-7340237 | 1206 | G503-7371238 | 0105.1 | G503-7373165 | 0802.5 |
| G503-7343032 | 1604.1 | G503-7371258 | 0105.2 | G503-7373166 | 0802.7 |
| G503-7343086 | 0613.1 | G503-7371264 | 0106.6 | G503-7373185 | 0802.5 |
| G503-7343368 | 0301 | G503-7371267 | 0106.6 | G503-7373188 | 1004 |
| G503-7348852 | 1204.3 | G503-7371268 | 0106.1 | G503-7375440 | 1204.1 |
| G503-7351395 | 0202 | G503-7371270 | 0106.1 | G503-7375797 | 0202 |
| G503-7361994 | {0312 | G503-7371271 | 0106.1 | G503-7378054 | 0301 |
| | 2002.5 | G503-7371272 | 0106.5 | G503-7378081 | 0301 |
| G503-7362105 | 0504 | G503-7371275 | 0106.1 | G503-7378099 | 0301 |
| G503-7362371 | 1204.1 | G503-7371278 | 0106.6 | G503-7387807 | 1311 |
| G503-7367859 | 1401 | G503-7371279 | 0106.1 | G503-7388074 | 0106.6 |
| G503-7368260 | 0202 | G503-7371281 | 0102.2 | G503-7416462 | 1401 |
| G503-7368267 | 0106.5 | G503-7371283 | 0106.6 | G503-7416485 | 1006 |
| G503-7371009 | 1204.5 | G503-7371286 | 0106.5 | G503-7416486 | 1006 |
| G503-7371030 | 1401 | G503-7371311 | 0615 | G503-7417607 | 1204.1 |
| G503-7371035 | 0802.7 | G503-7371337 | 0202 | G503-7418660 | 1812 |
| G503-7371037 | {0800 | G503-7371338 | 0202 | G503-7520991 | 1004 |
| | 1501 | G503-7371339 | 0202 | G503-7521218 | 0102.2 |
| G503-7371047 | 0401 | G503-7371340 | 0202 | G503-7524312 | 1503 |
| G503-7371055 | {1601.1 | G503-7371342 | 0202 | G503-7524313 | 1503 |
| | 1601.3 | G503-7371363 | 0202 | G503-7524315 | 1503 |
| G503-7371056 | 1501 | G503-7371364 | 0202 | G503-7540093 | 1006 |
| G503-7371061 | {1601.1 | G503-7371366 | 0202 | G503-7540096 | 1006 |
| | 1601.3 | G503-7371368 | 0201 | G503-7696350 | 1401 |
| G503-7371090 | {1601.1 | G503-7371371 | 0802.5 | G503-7696351 | 1401 |
| | 1601.3 | G503-7371376 | 0102.1 | G503-7696352 | 1401 |
| G503-7371099 | 0802.7 | G503-7371383 | 0504 | G503-7696370 | 1401 |
| G503-7371102 | 1002 | G503-7371385 | 0504 | G503-7696371 | 1401 |
| G503-7371103 | 1001 | G503-7371390 | 0401 | G503-7696374 | 1401 |
| G503-7371105 | 1004 | G503-7371454 | 0312 | G503-7696479 | {0802.5 |
| G503-7371106 | 1311 | G503-7371493 | 0102.2 | | 0802.7 |
| G503-7371108 | 1004 | G503-7371503 | 0102.2 | G503-7696481 | 0804 |
| G503-7371110 | 1006 | G503-7371504 | 0102.2 | G503-7696482 | 1004 |
| G503-7371112 | 1204.3 | G503-7371759 | 0800 | G503-7696491 | {0804 |
| G503-7371144 | 0104.1 | G503-7372318 | 1204.1 | | 2002.5 |
| G503-7371145 | 0104.1 | G503-7372342 | 1204.1 | G503-7696494 | 0802.5 |
| G503-7371146 | 0104.1 | G503-7372343 | 1204.5 | G503-7696512 | 1002 |
| G503-7371147 | 0104.1 | G503-7372447 | 0704 | G503-7696518 | 1004 |
| G503-7371159 | 0105.5 | G503-7372448 | 0704 | G503-7696520 | 1311 |
| G503-7371160 | 0102.1 | G503-7372456 | 0704 | G503-7696521 | 1311 |
| G503-7371161 | 0102.1 | G503-7373108 | 1006 | G503-7696523 | 1004 |
| G503-7371188 | {0601.1 | G503-7373111 | 1401 | G503-7696526 | 1004 |
| | 0601.3 | G503-7373112 | 0804 | G503-7697855 | 1201 |
| G503-7371193 | 0312 | G503-7373115 | 0802.7 | G503-7697864 | 0102.1 |
| G503-7371194 | 0312 | G503-7373116 | 0804 | G503-7697870 | 1501 |
| G503-7371195 | {0613.1 | G503-7373117 | 0804 | G503-7698489 | 1808 |
| | 2202 | G503-7373118 | 0804 | G503-7698490 | 1808 |
| G503-7371204 | 0802.7 | G503-7373119 | 0804 | G503-7701013 | 0108 |
| G503-7371210 | 0801 | G503-7373121 | 1002 | G503-7701327 | 1801 |
| G503-7371212 | 0802.5 | G503-7373146 | 1002 | G503-7701328 | 1801 |
| G503-7371213 | 0802.3 | G503-7373148 | 1004 | G503-7702465 | 0900 |
| G503-7371226 | 0102.1 | G503-7373156 | 0802.5 | G503-7706790 | 0604.1 |
| G503-7371227 | 0102.2 | G503-7373157 | {0802.5 | G503-7735833 | {1601.1 |
| G503-7371229 | 0102.2 | | 0802.7 | | 1601.3 |
| G503-7371231 | 0103 | G503-7373158 | 0802.7 | G503-7735842 | 1601.1 |
| G503-7371235 | 0105.1 | G503-7373159 | 0802.7 | G503-7735843 | {1601.1 |
| G503-7371237 | 0105.1 | G503-7373160 | 0802.7 | | 1601.3 |
| | | G503-7373162 | 0801 | G503-7741406 | 0105.5 |

ORDNANCE STOCK NUMBER INDEX—Continued

| STOCK NO. | SUBGROUP | STOCK NO. | SUBGROUP | STOCK NO. | SUBGROUP |
|--------------|----------|--------------|----------|--------------|----------|
| G503-7741407 | 0105.3 | G518-0389792 | 1202 | G740-7348604 | {1002 |
| G503-7741414 | 0105.5 | G518-5304050 | 1202 | | }1102 |
| G503-7741415 | 0105.5 | G518-7000997 | 2202 | G740-7348605 | 1004 |
| G503-7741419 | 0105.5 | G518-7001411 | 1202 | G740-7348609 | 1204.3 |
| G503-7741420 | 0105.1 | G529-7412179 | 1202 | G740-7348610 | 1204.3 |
| G503-7741427 | 0105.5 | G592-7722333 | {0613.1 | G740-7348611 | 1201 |
| G503-7743569 | 0105.2 | | }0617 | G740-7348759 | 1006 |
| G503-7743652 | 0802.1 | G592-7723309 | {0613.1 | G740-7348762 | 1006 |
| G503-7743751 | 0104.2 | | }0617 | G740-7348763 | 1006 |
| G503-7743752 | 0104.2 | G592-7731428 | 0617 | G740-7348764 | 1006 |
| G503-7743818 | 0102.1 | G671-7001905 | 0302.1 | G740-7348765 | 1006 |
| G503-7744319 | 0105.3 | G671-7001906 | 0302.1 | G740-7348766 | 1006 |
| G503-7744324 | 0106.1 | G716-5293056 | 0301 | G740-7348767 | 1006 |
| G503-7744331 | 0106.1 | G716-7347355 | 0604.1 | G740-7348768 | 1006 |
| G503-7744332 | 0106.1 | G716-7411250 | 0504 | G740-7351313 | 1104.1 |
| G503-7744333 | 0106.1 | G716-8329517 | 0105.1 | G740-7351314 | 1805 |
| G503-7744469 | 0102.1 | G716-8329518 | 0105.1 | G740-7351315 | 0309 |
| G503-7744471 | 0104.2 | G716-8329519 | 0105.1 | G740-7351316 | 0309 |
| G503-7744472 | {0104.2 | G716-8329694 | 0105.1 | G740-7351376 | 1401 |
| | }0105.2 | G716-8329966 | 0503 | G740-7351403 | 1006 |
| G503-7744473 | 0102.1 | G716-8673476 | 0102.1 | G740-7351404 | 1006 |
| G503-8387940 | {0202 | G732-5214750 | 0302.1 | G740-7351413 | 0105.3 |
| | }1206 | G740-5336400 | 0304.5 | G740-7369850 | 0801 |
| G503-8393055 | 1401 | G740-7032605 | 0304.5 | G740-7369880 | 0501 |
| G505-0682454 | 0609.1 | G740-7032606 | 1104.1 | G740-7369881 | 0106.2 |
| G505-5346736 | 0301 | G740-7032607 | 0304.5 | G740-7369951 | 2201 |
| G505-8376245 | 0702.3 | G740-7032623 | 0704 | G740-7372448 | 0704 |
| G505-8376246 | 0702.3 | G740-7032624 | 0704 | G740-7372500 | 0301 |
| G506-7538146 | 0609.1 | G740-7032625 | 1204.5 | G740-7372502 | 0301 |
| G506-7538582 | 0609.1 | G740-7032626 | 1006 | G740-7372506 | 1501 |
| G507-5293063 | 0301 | G740-7032628 | 1004 | G740-7372507 | 1501 |
| G507-5307283 | 0604.1 | G740-7032629 | 1101 | G740-7372511 | 0301 |
| G507-5308275 | 0603 | G740-7032630 | 1102 | G740-7372512 | 0301 |
| G507-5308307 | 0603 | G740-7032631 | 1102 | G740-7372513 | 0301 |
| G507-5312057 | 0301 | G740-7032632 | 1102 | G740-7372514 | 0301 |
| G507-5346738 | 0301 | G740-7032633 | 1102 | G740-7372517 | 0301 |
| G507-5346767 | 0604.1 | G740-7032634 | 1102 | G740-7372519 | 0301 |
| G507-5346768 | 0604.1 | G740-7047970 | 0304.5 | G740-7372520 | 0301 |
| G507-5346774 | 0604.1 | G740-7047998 | {0304.5 | G740-7372521 | 0301 |
| G507-5346775 | 0604.1 | | }0613.1 | G740-7372522 | 0301 |
| G507-5346784 | 0604.1 | G740-7048736 | 0401 | G740-7372525 | 0301 |
| G507-6245928 | 0106.2 | G740-7065900 | 0704 | G740-7372528 | 0301 |
| G507-7410270 | 0302.1 | G740-7346940 | 0612 | G740-7372529 | 0301 |
| G507-7702608 | 0602 | | {0612 | G740-7372530 | 0301 |
| G507-7702645 | 0602 | G740-7346945 | {0613.1 | G740-7372531 | 0301 |
| G507-7702646 | 0602 | | }2208.1 | G740-7372533 | 0301 |
| G508-5160323 | 1204.1 | G740-7347733 | 1006 | G740-7372534 | 0301 |
| G508-5214539 | {0603 | G740-7348525 | 2201 | G740-7372536 | 0301 |
| | }1204.1 | G740-7348567 | {1804 | G740-7372537 | 0301 |
| G508-5214752 | 0302.1 | | }1805 | G740-7372538 | 0301 |
| G508-5214889 | 0302.1 | G740-7348568 | 0304.1 | G740-7372539 | 0301 |
| G508-5214987 | 0302.1 | G740-7348571 | 0503 | G740-7372541 | 0301 |
| G508-5293034 | 0301 | G740-7348574 | 0611 | G740-7372542 | 0301 |
| G509-0389511 | 0106.2 | G740-7348578 | 0604.1 | G740-7372544 | 0100.2 |
| G509-5308281 | 0106.2 | G740-7348602 | 1001 | G740-7372545 | 0100.2 |
| G509-7016403 | 0302.1 | G740-7348603 | 1002 | G740-7372551 | 0100.2 |
| G509-7058965 | 2202 | | | G740-7372554 | 0304.5 |
| G509-7529093 | 0106.2 | | | | |

ORDNANCE STOCK NUMBER INDEX—Continued

| STOCK NO. | SUBGROUP | STOCK NO. | SUBGROUP | STOCK NO. | SUBGROUP |
|--------------|----------|--------------|----------|--------------|----------|
| G740-7372557 | 0106.6 | G740-7372846 | {1002 | G740-7374967 | 0804 |
| G740-7372558 | 0102.1 | | {1102 | G740-7374968 | 0804 |
| G740-7372559 | 0102.1 | G740-7372847 | {1002 | G740-7374969 | 0704 |
| G740-7372560 | 0102.1 | | {1102 | G740-7374970 | 0704 |
| G740-7372564 | 0102.2 | G740-7372848 | {1002 | G740-7374971 | 0704 |
| G740-7372565 | 0102.2 | | {1102 | G740-7374972 | 0704 |
| G740-7372566 | 0102.2 | G740-7372849 | {1002 | G740-7374973 | 0704 |
| G740-7372567 | 0102.2 | | {1102 | G740-7374974 | 0704 |
| G740-7372568 | 0102.2 | G740-7372850 | {1002 | G740-7374975 | 0704 |
| G740-7372569 | 0102.2 | | {1102 | G740-7374976 | 0704 |
| G740-7372570 | 0102.2 | G740-7372851 | {1002 | G740-7374977 | 0704 |
| G740-7372571 | 0102.2 | | {1102 | G740-7374978 | 0704 |
| G740-7372572 | 0102.2 | G740-7372852 | {1002 | G740-7374979 | 0704 |
| G740-7372573 | 0102.2 | | {1102 | G740-7374980 | 0704 |
| G740-7372574 | 0102.2 | G740-7372853 | {1002 | G740-7374983 | 1104.1 |
| G740-7372575 | 0102.2 | | {1102 | G740-7374984 | 1104.1 |
| G740-7372576 | 0105.5 | G740-7372854 | 1002 | G740-7374985 | 1104.1 |
| G740-7372578 | 0105.5 | G740-7372855 | {1002 | G740-7374986 | 1104.1 |
| G740-7372579 | 0105.5 | | {1102 | G740-7374987 | 1104.1 |
| G740-7372585 | 0105.2 | G740-7372856 | 1002 | G740-7374990 | 0802.5 |
| G740-7372586 | 0106.1 | G740-7372857 | 1002 | G740-7374991 | 0702.3 |
| G740-7372587 | 0106.1 | G740-7372858 | {1002 | G740-7374992 | 0702.3 |
| G740-7372661 | 0201 | | {1102 | G740-7374993 | 0702.3 |
| G740-7372667 | 0702.5 | G740-7372859 | 1002 | G740-7374994 | 0702.3 |
| G740-7372670 | 1806 | G740-7372860 | 1002 | G740-7374995 | 0702.3 |
| G740-7372678 | 1101 | G740-7372863 | {1002 | G740-7374996 | 0702.3 |
| G740-7372679 | 1102 | | {1102 | G740-7374998 | 0702.3 |
| G740-7372806 | 0504 | G740-7372864 | 1006 | G740-7374999 | 0702.3 |
| G740-7372807 | 0504 | G740-7372865 | 1006 | G740-7375000 | 1601.3 |
| G740-7372808 | 0503 | G740-7372866 | 1006 | G740-7375001 | 1601.3 |
| G740-7372809 | 0504 | G740-7372867 | 1006 | G740-7375005 | 1601.3 |
| G740-7372810 | 0504 | | {0802.5 | G740-7375006 | {1601.1 |
| G740-7372816 | 0505 | G740-7372868 | {0802.7 | | {1601.3 |
| G740-7372818 | 2101 | | {1102 | G740-7375007 | 1806 |
| G740-7372819 | 2101 | G740-7372869 | 1006 | G740-7375008 | 1806 |
| G740-7372820 | 2101 | G740-7372870 | 1006 | G740-7375012 | 0306 |
| G740-7372822 | 0202 | G740-7372872 | 1006 | G740-7375020 | 0306 |
| G740-7372823 | 0202 | G740-7372873 | 0104.1 | G740-7375021 | 0505 |
| G740-7372826 | 0202 | G740-7372874 | 0104.1 | G740-7375022 | 0609.1 |
| G740-7372827 | {0202 | G740-7372875 | 0104.1 | G740-7375023 | 0609.1 |
| | {1206 | G740-7372876 | 0104.1 | G740-7375024 | 0609.1 |
| G740-7372832 | 0106.6 | G740-7372877 | 0701 | G740-7375028 | 0102.1 |
| G740-7372833 | 1204.5 | G740-7372878 | 0800 | G740-7375030 | 0501 |
| G740-7372834 | 1204.5 | | {0701 | G740-7375032 | 0105.1 |
| G740-7372835 | 1204.5 | G740-7372879 | {0801 | G740-7375033 | 0105.1 |
| G740-7372836 | 1204.5 | | {1004 | G740-7375034 | 0105.1 |
| G740-7372837 | 1204.5 | | {0609.2 | G740-7375035 | 0105.1 |
| G740-7372838 | 1204.3 | | {1804 | G740-7375036 | 0306 |
| G740-7372839 | 1204.5 | G740-7372885 | {1805 | G740-7375045 | 1004 |
| G740-7372840 | 1206 | | {1806 | G740-7375048 | 1004 |
| G740-7372842 | 1001 | | {1808 | G740-7375049 | 1004 |
| G740-7372843 | {1002 | G740-7372886 | {1701 | G740-7375051 | 0801 |
| | {1102 | | {2101 | G740-7375052 | 0801 |
| G740-7372844 | {1002 | G740-7372889 | 2201 | G740-7375053 | 0801 |
| | {1102 | G740-7372890 | 2201 | G740-7375056 | 0106.2 |
| G740-7372845 | {1002 | G740-7372891 | 2201 | G740-7375057 | 0106.2 |
| | {1102 | G740-7372898 | 2201 | G740-7375058 | 0106.2 |
| | | G740-7374966 | 0804 | G740-7375059 | 0106.2 |
| | | | | G740-7375060 | 0106.2 |

ORDNANCE STOCK NUMBER INDEX—Continued

| STOCK NO. | SUBGROUP | STOCK NO. | SUBGROUP | STOCK NO. | SUBGROUP |
|--------------|----------|--------------|----------|--------------|----------|
| G740-7375063 | 0304.5 | G740-7375337 | 1401 | G740-7411927 | 2001.1 |
| G740-7375064 | 0312 | G740-7375339 | 1401 | G740-7411930 | 2001.1 |
| G740-7375065 | {0202 | G740-7375341 | 1401 | G740-7411931 | 2001.1 |
| | 1206 | G740-7375347 | 1401 | G740-7411932 | 2001.1 |
| G740-7375071 | {0601.1 | G740-7375348 | 1401 | G740-7411933 | 2001.1 |
| | 0601.3 | G740-7375349 | 1401 | G740-7411934 | 2001.1 |
| G740-7375075 | 0401 | G740-7375350 | 1808 | G740-7411935 | 2001.1 |
| G740-7375076 | 0401 | G740-7375351 | 1808 | G740-7411936 | 2001.1 |
| G740-7375077 | 0401 | G740-7375353 | 1808 | G740-7411937 | 2001.1 |
| G740-7375081 | 0800 | G740-7375354 | 1808 | G740-7411938 | 2001.1 |
| G740-7375082 | 0800 | G740-7375355 | 1808 | G740-7411939 | 2001.1 |
| G740-7375110 | 0604.1 | G740-7375357 | 0602 | G740-7411940 | {2001.1 |
| G740-7375112 | 0312 | G740-7375358 | 1808 | | 2002.1 |
| G740-7375114 | 0312 | G740-7375371 | {0602 | G740-7411941 | 2001.1 |
| G740-7375128 | 0304.5 | | 0604.1 | G740-7411942 | 2001.1 |
| G740-7375129 | 0312 | G740-7375372 | 0604.1 | G740-7411943 | 2001.1 |
| G740-7375131 | 0802.1 | G740-7375373 | 0604.1 | G740-7411944 | 2001.1 |
| G740-7375132 | 0802.1 | G740-7375376 | 0604.1 | G740-7411945 | 2001.1 |
| G740-7375133 | 0802.3 | G740-7375377 | 0604.1 | G740-7411950 | 2001.3 |
| G740-7375134 | 0802.3 | G740-7375378 | 0604.1 | G740-7411953 | 2001.3 |
| G740-7375135 | 0802.3 | G740-7375381 | 0302.1 | G740-7411954 | 2001.5 |
| G740-7375136 | 1104.1 | G740-7375382 | 0302.1 | G740-7411955 | 2001.5 |
| G740-7375137 | 1311 | G740-7375383 | 0302.1 | G740-7411956 | 2001.5 |
| G740-7375138 | 1104.1 | G740-7375385 | 0302.1 | G740-7411957 | 2001.5 |
| G740-7375139 | 1311 | G740-7375388 | {0601.1 | G740-7411958 | 2001.5 |
| G740-7375142 | 1311 | | 0601.3 | G740-7411959 | 2001.5 |
| G740-7375143 | 1311 | G740-7375389 | {0601.1 | G740-7411961 | 2002.1 |
| G740-7375144 | 1311 | | 0601.3 | G740-7411962 | 2002.1 |
| G740-7375146 | 0610 | G740-7375392 | 0312 | G740-7411963 | 2002.1 |
| G740-7375153 | 2002.5 | G740-7375399 | 1808 | G740-7411964 | 2002.1 |
| G740-7375155 | 1401 | G740-7376904 | 0106.6 | G740-7411965 | 2002.1 |
| G740-7375158 | 1805 | G740-7376905 | 1806 | G740-7411966 | 2002.1 |
| G740-7375163 | 1808 | G740-7376907 | 0106.1 | G740-7411967 | 2002.1 |
| G740-7375166 | 1808 | G740-7410836 | {0106.5 | G740-7411970 | 2002.1 |
| G740-7375169 | 1808 | | 0304.5 | G740-7411971 | 2002.1 |
| G740-7375170 | 1805 | G740-7410837 | 1503 | G740-7411972 | 2002.1 |
| G740-7375174 | {0601.1 | G740-7410838 | 1503 | G740-7411973 | 2002.5 |
| | 0601.3 | G740-7411646 | 2001.3 | G740-7411974 | 2002.5 |
| G740-7375175 | {0601.1 | G740-7411677 | 2001.3 | G740-7411975 | 2002.5 |
| | 0601.3 | G740-7411681 | 2001.3 | G740-7411976 | 2002.5 |
| G740-7375176 | 1204.1 | G740-7411685 | 2001.3 | G740-7411977 | 2002.5 |
| G740-7375177 | 1401 | G740-7411687 | 2001.3 | G740-7411979 | 2002.5 |
| G740-7375178 | 1401 | G740-7411690 | {2001.3 | G740-7411980 | 2002.5 |
| G740-7375179 | 1401 | | 2002.1 | G740-7411981 | 2002.5 |
| G740-7375180 | 1401 | G740-7411799 | 2001.1 | G740-7411982 | 2002.5 |
| G740-7375181 | 1401 | G740-7411800 | 2001.1 | G740-7411983 | 2002.5 |
| G740-7375182 | 1401 | G740-7411801 | 2001.1 | G740-7412437 | 0601.1 |
| G740-7375183 | 1401 | G740-7411802 | 2001.1 | G740-7412438 | 0601.1 |
| G740-7375189 | 2202 | G740-7411803 | 2001.1 | G740-7412442 | 0611 |
| G740-7375190 | 2202 | G740-7411804 | 2001.1 | G740-7412445 | 1401 |
| G740-7375192 | 1102 | G740-7411805 | 2001.1 | G740-7412446 | 1401 |
| G740-7375195 | 1102 | G740-7411920 | 2001.1 | G740-7412576 | 1401 |
| G740-7375197 | 1102 | G740-7411921 | 2001.1 | G740-7412577 | 1401 |
| G740-7375301 | 0603 | G740-7411922 | 2001.1 | G740-7412579 | 1401 |
| G740-7375312 | 1804 | G740-7411923 | 2001.1 | G740-7412580 | 1401 |
| G740-7375324 | 2201 | G740-7411924 | 2001.1 | G740-7412583 | 2210 |
| G740-7375330 | 0601.1 | G740-7411925 | 2001.1 | G740-7412641 | 0607 |
| G740-7375336 | 1401 | G740-7411926 | 2001.1 | G740-7412643 | 0613.1 |

ORDNANCE STOCK NUMBER INDEX—Continued

| STOCK NO. | SUBGROUP | STOCK NO. | SUBGROUP | STOCK NO. | SUBGROUP |
|--------------|----------|--------------|----------|--------------|----------|
| G740-7412959 | 0301 | G740-7697499 | 1806 | G740-7697596 | {1601.1 |
| G740-7412960 | 0604.1 | G740-7697501 | 1806 | | }1601.3 |
| G740-7416478 | 0302.1 | G740-7697502 | 1806 | G740-7697598 | {1601.1 |
| G740-7416521 | 0608 | G740-7697505 | 1806 | | }1601.3 |
| G740-7416524 | 1204.1 | G740-7697506 | 1806 | G740-7697600 | 1601.1 |
| G740-7418140 | 1204.1 | G740-7697507 | 1806 | G740-7697601 | 1601.1 |
| G740-7418146 | 1204.5 | G740-7697508 | 1806 | G740-7697602 | {1601.1 |
| G740-7418147 | 1804 | G740-7697509 | 1806 | | }1601.3 |
| G740-7418148 | 1804 | G740-7697510 | 1806 | G740-7697606 | 1002 |
| G740-7418343 | 0609.1 | G740-7697512 | 1503 | G740-7697608 | 0900 |
| G740-7418835 | 0607 | G740-7697513 | 1801 | G740-7697611 | 0900 |
| G740-7524316 | 1503 | G740-7697514 | 1801 | G740-7697613 | 0900 |
| G740-7539310 | 1204.1 | G740-7697515 | {1804 | G740-7697614 | 0505 |
| G740-7697418 | 2201 | | }1805 | G740-7716654 | 0601.1 |
| G740-7697419 | 0702.5 | G740-7697519 | 1805 | G740-7731429 | 0617 |
| G740-7697420 | 0702.5 | G740-7697520 | 1805 | G740-7760417 | 0603 |
| G740-7697421 | 0702.5 | G740-7697521 | 1805 | G740-7994190 | 2001.3 |
| G740-7697422 | 0702.5 | G740-7697522 | 1805 | G740-7994194 | 2001.3 |
| G740-7697423 | 0702.5 | G740-7697523 | 1805 | G740-7994778 | 1004 |
| G740-7697424 | 0702.5 | G740-7697525 | 1805 | G740-8328043 | 0100.2 |
| G740-7697425 | 0702.5 | G740-7697526 | 1805 | G740-8328046 | 0103 |
| G740-7697427 | 0702.5 | G740-7697527 | {1804 | G740-8328047 | 0103 |
| G740-7697428 | 0702.5 | | }1805 | G740-8328048 | 0103 |
| G740-7697429 | 0702.5 | G740-7697534 | 1806 | G740-8328049 | 0103 |
| G740-7697436 | 1504 | G740-7697535 | 1806 | G740-8328125 | 0103 |
| G740-7697439 | 1504 | G740-7697536 | 1806 | G740-8328126 | 0105.1 |
| | {1703 | G740-7697537 | 1806 | G740-8328127 | 0201 |
| G740-7697440 | 1804 | G740-7697538 | 1806 | G740-8328129 | 0202 |
| | {2201 | G740-7697539 | 1806 | G740-8328130 | 0202 |
| G740-7697441 | 1504 | G740-7697546 | 0702.5 | G740-8328132 | 0603 |
| G740-7697446 | {1803.1 | G740-7697547 | 0702.5 | G740-8328133 | 0603 |
| | }2101 | | | G740-8328134 | 0603 |
| G740-7697447 | 1803.1 | G740-7697548 | {1701 | G740-8328135 | 0603 |
| G740-7697452 | 1206 | | }1804 | G740-8328136 | 0603 |
| G740-7697453 | 1206 | G740-7697554 | 2210 | G740-8328139 | 0603 |
| G740-7697454 | {0202 | G740-7697555 | 2210 | G740-8328140 | 0603 |
| | }1206 | G740-7697561 | 2210 | G740-8328141 | 0603 |
| G740-7697459 | 1204.3 | G740-7697562 | 2210 | G740-8328144 | 0603 |
| G740-7697460 | 1204.3 | G740-7697564 | 0702.1 | G740-8328264 | 1503 |
| G740-7697461 | 1204.3 | G740-7697566 | 0702.1 | G740-8328265 | 0201 |
| G740-7697462 | 1204.3 | G740-7697567 | 0702.1 | G740-8328310 | 0103 |
| G740-7697463 | 1202 | G740-7697568 | 0702.1 | G740-8328311 | 0103 |
| G740-7697464 | 1202 | G740-7697569 | 0702.1 | G740-8328312 | 0103 |
| G740-7697465 | 1204.1 | G740-7697570 | 0702.1 | G740-8328313 | 0103 |
| G740-7697466 | 1206 | G740-7697571 | 0702.1 | G740-8329889 | 2002.5 |
| G740-7697467 | 0802.7 | G740-7697572 | 0702.1 | G740-8330745 | 0104.2 |
| G740-7697468 | 0802.7 | G740-7697574 | 1501 | G740-8330746 | 0104.2 |
| G740-7697470 | 0804 | G740-7697577 | 1805 | G740-8330747 | 0104.2 |
| G740-7697471 | 0700 | G740-7697578 | 1805 | G740-8330748 | 0104.2 |
| G740-7697473 | 1204.1 | G740-7697579 | 1805 | G740-8332072 | 0202 |
| G740-7697476 | 1204.1 | G740-7697581 | {1805 | G740-8376244 | 0702.3 |
| G740-7697477 | 1204.1 | | }1808 | G741-5214758 | 0302.1 |
| G740-7697478 | 1204.1 | G740-7697588 | 0503 | G741-5293030 | 0301 |
| G740-7697483 | 1703 | G740-7697592 | {1803.1 | G741-5346762 | 0603 |
| G740-7697487 | 1703 | | }2101 | G741-6170220 | 0302.1 |
| G740-7697489 | 1503 | G740-7697593 | 2201 | G741-7010695 | 0302.1 |
| G740-7697490 | 1503 | G740-7697594 | 2201 | G741-7346969 | 0604.1 |
| G740-7697497 | 1804 | G740-7697595 | 2201 | G741-7347547 | 0604.1 |

ORDNANCE STOCK NUMBER INDEX—Continued

| STOCK NO. | SUBGROUP | STOCK NO. | SUBGROUP | STOCK NO. | SUBGROUP |
|--------------|----------|--------------|----------|--------------|----------|
| G741-7347560 | 0602 | G741-7374945 | 0602 | G742-7526601 | 0607 |
| G741-7347568 | 0603 | G741-7374960 | 0602 | G742-7529242 | 0609.1 |
| G741-7347571 | 0603 | G741-7374961 | 0602 | G742-7538749 | 0601.3 |
| G741-7347572 | 0603 | G741-7374964 | 0602 | G742-7538750 | 0601.3 |
| G741-7347573 | 0601.1 | G741-7374965 | 0602 | G742-7538751 | 0601.3 |
| G741-7348949 | 0602 | G741-7412783 | 0609.2 | G742-7538753 | 0601.3 |
| G741-7351052 | 0704 | G741-7413199 | 0302.1 | G742-7538754 | 0601.3 |
| G741-7351133 | 0604.1 | G741-7413315 | 0601.3 | G742-7538756 | 0601.3 |
| G741-7355736 | 0601.3 | G741-7413317 | 0601.3 | G742-7538757 | 0601.3 |
| G741-7369888 | 0603 | G741-7413318 | 0601.3 | G742-7538759 | 0601.3 |
| G741-7369889 | 0603 | G741-7413319 | 0601.3 | G742-7538760 | 0601.3 |
| G741-7374746 | 0601.1 | G741-7524309 | 0602 | G742-7538761 | 0601.3 |
| G741-7374748 | 0601.1 | G741-7526592 | 0607 | G742-7538762 | 0601.3 |
| G741-7374749 | 0601.1 | G741-7526594 | 0607 | G742-7538763 | 0601.3 |
| G741-7374750 | 0601.1 | G741-7526595 | 0607 | G742-7538765 | 0601.3 |
| G741-7374822 | 0602 | G741-7526596 | 0607 | G742-7538767 | 0601.3 |
| G741-7374823 | 0602 | G741-7526600 | 0607 | G742-7538777 | 0601.3 |
| G741-7374825 | 0602 | G741-7705721 | 0201 | G742-7538783 | 0601.3 |
| G741-7374851 | 0601.1 | G741-7722367 | 0613.1 | G742-7538784 | 0601.3 |
| G741-7374852 | 0601.1 | G741-7722368 | 0613.1 | G742-7538785 | 0601.3 |
| G741-7374853 | 0601.1 | G741-7760504 | 0609.1 | G742-7538786 | 0601.3 |
| G741-7374854 | 0601.1 | G741-8327721 | 0601.1 | G742-7538787 | 0601.3 |
| G741-7374855 | 0601.1 | G741-8328056 | 0603 | G742-7539125 | 0302.1 |
| G741-7374856 | 0601.1 | G741-8328057 | 0603 | G742-7539516 | 0607 |
| G741-7374857 | 0601.1 | G741-8328058 | 0603 | G742-7539517 | 0607 |
| G741-7374858 | 0601.1 | G741-8328061 | 0603 | G742-7539519 | 0607 |
| G741-7374859 | 0601.1 | G741-8328062 | 0603 | G742-7539541 | 0609.1 |
| G741-7374860 | 0601.1 | G741-8328063 | 0603 | G742-7539688 | 2208.1 |
| G741-7374861 | 0601.1 | G741-8328064 | 0603 | G742-7539689 | 2208.1 |
| G741-7374862 | 0601.1 | G741-8328065 | 0603 | G742-7716690 | 0601.3 |
| G741-7374863 | 0601.1 | G741-8328066 | 0603 | | |
| G741-7374865 | 0601.3 | G741-8328067 | 0603 | G742-7728341 | 0611 |
| G741-7374866 | 0601.3 | G741-8328069 | 0603 | G742-7728788 | 0608 |
| G741-7374878 | 0604.1 | G741-8328071 | 0603 | G742-7728852 | 0607 |
| G741-7374881 | 0604.1 | G741-8328076 | 0604.1 | G742-7728853 | 0607 |
| G741-7374882 | 0604.1 | G741-8332226 | 0601.1 | G742-7728854 | 0607 |
| | 0605 | G741-8332556 | 0304.5 | G742-7728856 | 0610 |
| G741-7374885 | 0604.1 | G742-5167516 | 0802.7 | G742-7730893 | 0613.1 |
| G741-7374886 | 0601.1 | G742-5701238 | 0601.3 | G742-7731435 | 0613.1 |
| G741-7374887 | 0604.1 | G742-7372727 | 0607 | G742-7760396 | 2208.1 |
| G741-7374888 | 0604.1 | G742-7372738 | 0607 | G742-7760409 | 0607 |
| G741-7374893 | 0604.1 | G742-7372752 | 0304.5 | G742-7760412 | 0607 |
| G741-7374894 | 0604.1 | G742-7373350 | 0601.3 | G742-7760418 | 0607 |
| G741-7374895 | 0604.1 | G742-7373354 | 1204.1 | G742-7760503 | 0609.1 |
| G741-7374917 | 0602 | G742-7384388 | 0607 | G742-7954230 | 0607 |
| G741-7374918 | 0602 | G742-7384389 | 0607 | G742-7954231 | 0610 |
| G741-7374919 | 0602 | G742-7384392 | 0607 | G742-7954511 | 0607 |
| G741-7374920 | 0602 | G742-7388813 | 0608 | G742-8376374 | 0607 |
| G741-7374921 | 0602 | G742-7389566 | 0610 | G742-8376375 | 2208.1 |
| G741-7374922 | 0602 | G742-7389567 | 0607 | G742-8376377 | 0607 |
| G741-7374923 | 0602 | G742-7391017 | 0601.3 | G744-7355830 | 2208.1 |
| G741-7374924 | 0602 | G742-7391018 | 0601.3 | G744-7375694 | 0609.1 |
| G741-7374925 | 0602 | G742-7525365 | 0609.1 | G744-7389881 | 2208.1 |
| G741-7374930 | 0603 | G742-7525936 | 0609.1 | G744-7409316 | 1204.1 |
| G741-7374938 | 0603 | G742-7525937 | 0609.1 | G744-7409702 | 2208.1 |
| G741-7374940 | 0603 | G742-7525940 | 0609.1 | G744-7411069 | 1204.1 |
| G741-7374943 | 0602 | G742-7526023 | 0609.1 | G744-7712833 | 0609.1 |
| G741-7374944 | 0602 | G742-7526591 | 0607 | G744-8333722 | 0306 |

ORDNANCE STOCK NUMBER INDEX—Continued

| STOCK NO. | SUBGROUP | STOCK NO. | SUBGROUP | STOCK NO. | SUBGROUP |
|--------------|----------|--------------|----------|--------------|----------|
| G747-7328291 | 1311 | G758-8328469 | 1703 | G758-8329642 | 0304.1 |
| G747-7328292 | 1311 | G758-8328470 | 1703 | G758-8329643 | 0304.1 |
| G747-7328371 | 1311 | G758-8328471 | 1703 | G758-8329644 | 0304.1 |
| G747-7328375 | 1311 | G758-8328472 | 1703 | G758-8329645 | 0304.5 |
| G747-7328376 | 1311 | G758-8328474 | 0101 | G758-8329646 | 0304.1 |
| G747-7355938 | 0617 | G758-8328475 | 1501 | G758-8329647 | 0304.1 |
| G749-5291787 | 0304.5 | G758-8328478 | 0802.7 | G758-8329648 | 0304.1 |
| G749-5294507 | 0609.1 | G758-8328479 | 0802.7 | G758-8329649 | 1601.1 |
| G749-6246309 | 0304.5 | G758-8328480 | 2208.1 | G758-8329650 | 1808 |
| G749-7039934 | 0106.2 | G758-8328481 | 2208.1 | G758-8329651 | 1804 |
| G749-7358619 | 0607 | G758-8328483 | 0103 | G758-8329652 | 1804 |
| G749-7368702 | 0607 | G758-8328484 | 0103 | G758-8329653 | 1804 |
| G749-7526002 | 0609.1 | G758-8328486 | 1806 | G758-8329654 | 1808 |
| G758-7010699 | 0302.1 | G758-8328487 | 1806 | G758-8329655 | 1808 |
| G758-7351892 | 0106.6 | G758-8328488 | 1806 | G758-8329656 | 1804 |
| G758-7358569 | 0604.1 | G758-8328489 | 1806 | G758-8329658 | 1804 |
| G758-7971279 | 0302.1 | G758-8328490 | 0501 | G758-8329659 | 1804 |
| G758-7994148 | 2002.1 | G758-8328491 | 0501 | G758-8329662 | 0613.1 |
| G758-8328005 | 1102 | G758-8328492 | 0501 | G758-8329663 | 0612 |
| G758-8328391 | 0100.2 | G758-8328495 | 0900 | G758-8329664 | 0612 |
| G758-8328393 | 0100.2 | G758-8328496 | 0900 | G758-8329665 | 0612 |
| G758-8328396 | 0100.1 | G758-8328497 | 0900 | G758-8329666 | 0612 |
| G758-8328397 | 1004 | G758-8328498 | 0900 | G758-8329668 | 1204.1 |
| G758-8328398 | 1004 | G758-8328499 | 0900 | G758-8329674 | 0802.5 |
| G758-8328405 | 0106.6 | G758-8329600 | 1601.1 | G758-8329675 | 0101 |
| G758-8328406 | 0106.6 | | 1601.3 | G758-8329676 | 0101 |
| G758-8328407 | 0106.6 | G758-8329601 | 1601.1 | G758-8329677 | 0101 |
| G758-8328408 | 0106.6 | G758-8329602 | 1601.1 | G758-8329678 | 0101 |
| G758-8328409 | 0106.6 | | 1601.3 | G758-8329679 | 0101 |
| G758-8328410 | 0106.6 | G758-8329603 | 1601.3 | G758-8329680 | 0101 |
| G758-8328414 | 1002 | G758-8329605 | 0604.1 | G758-8329683 | 0106.5 |
| G758-8328417 | 1701 | G758-8329606 | 0304.5 | G758-8329684 | 0106.5 |
| G758-8328418 | 1701 | G758-8329607 | 1202 | G758-8329686 | 0610 |
| G758-8328420 | 1701 | G758-8329608 | 1202 | G758-8329687 | 0610 |
| G758-8328421 | 1701 | G758-8329609 | 1202 | G758-8329688 | 0611 |
| G758-8328422 | 0106.2 | G758-8329611 | 1202 | G758-8329689 | 0611 |
| G758-8328436 | 0202 | G758-8329613 | 0303 | G758-8329690 | 0611 |
| | 1206 | G758-8329614 | 0306 | G758-8329691 | 0105.1 |
| G758-8328437 | 0202 | G758-8329615 | 0306 | G758-8329693 | 0105.1 |
| G758-8328439 | 0202 | G758-8329616 | 0306 | G758-8329694 | 0105.1 |
| G758-8328440 | 0802.5 | G758-8329617 | 0306 | G758-8329695 | 0105.1 |
| G758-8328441 | 0309 | G758-8329618 | 0306 | G758-8329696 | 0105.1 |
| G758-8328442 | 1204.3 | G758-8329619 | 0306 | G758-8329697 | 0105.1 |
| G758-8328443 | 1204.3 | G758-8329621 | 0306 | G758-8329698 | 0105.3 |
| G758-8328444 | 1204.3 | G758-8329623 | 1201 | G758-8329699 | 0108 |
| G758-8328445 | 1204.3 | G758-8329626 | 1201 | G758-8329700 | 0900 |
| G758-8328446 | 1501 | G758-8329627 | 1201 | G758-8329701 | 0302.1 |
| G758-8328448 | 1503 | G758-8329629 | 1201 | G758-8329702 | 0302.1 |
| G758-8328449 | 0605 | G758-8329630 | 1201 | G758-8329703 | 0302.1 |
| G758-8328455 | 0503 | G758-8329632 | 1201 | G758-8329704 | 0302.1 |
| G758-8328456 | 0503 | G758-8329633 | 1201 | G758-8329705 | 0302.1 |
| G758-8328457 | 0503 | G758-8329634 | 0304.5 | G758-8329706 | 0302.1 |
| G758-8328458 | 0503 | G758-8329636 | 0304.5 | G758-8329707 | 0302.1 |
| G758-8328461 | 1703 | G758-8329637 | 0304.5 | G758-8329708 | 0302.1 |
| G758-8328463 | 0101 | G758-8329638 | 0304.5 | G758-8329709 | 0302.1 |
| G758-8328464 | 1804 | G758-8329639 | 0304.5 | G758-8329710 | 0105.2 |
| G758-8328465 | 1804 | G758-8329640 | 0304.5 | G758-8329711 | 0105.2 |
| G758-8328468 | 1804 | G758-8329641 | 0304.5 | G758-8329712 | 0105.2 |

ORDNANCE STOCK NUMBER INDEX—Continued

| STOCK NO. | SUBGROUP | STOCK NO. | SUBGROUP | STOCK NO. | SUBGROUP |
|--------------|----------|--------------|----------|--------------|----------|
| G758-8329713 | 0105.2 | G758-8329783 | 0306 | G758-8330948 | {0312 |
| G758-8329714 | 0105.2 | G758-8329784 | 0604.1 | | }1201 |
| G758-8329715 | 0105.2 | G758-8329785 | 0604.1 | G758-8330950 | 1504 |
| G758-8329716 | 0105.2 | G758-8329786 | 0604.1 | G758-8331232 | 1601.1 |
| G758-8329717 | 0105.2 | G758-8329787 | 0604.1 | G758-8331234 | 1601.1 |
| G758-8329718 | 0105.2 | G758-8329825 | 0301 | G758-8331235 | 1601.1 |
| G758-8329719 | 0105.2 | G758-8329826 | 0301 | G758-8331236 | 1601.3 |
| G758-8329720 | 0105.2 | G758-8329828 | 0301 | G758-8331237 | 1601.3 |
| G758-8329721 | 0105.2 | G758-8329830 | 0301 | G758-8331238 | 1601.3 |
| G758-8329723 | 1401 | G758-8329831 | 0301 | G758-8331239 | 1601.3 |
| G758-8329724 | 1401 | G758-8329832 | 0301 | G758-8331246 | 0106.1 |
| G758-8329725 | 1401 | G758-8329833 | 0301 | G758-8331793 | {0802.5 |
| G758-8329726 | 1401 | G758-8329834 | 0301 | | }0802.7 |
| G758-8329727 | 1401 | G758-8329835 | 0301 | G758-8331831 | 2101 |
| G758-8329728 | 1401 | G758-8329836 | 0301 | G758-8331874 | 1204.1 |
| G758-8329729 | 1401 | G758-8329837 | 0301 | G758-8331932 | 0106.6 |
| G758-8329730 | 1401 | G758-8329850 | 1101 | G758-8331933 | 0306 |
| G758-8329732 | 1311 | G758-8329853 | 0701 | G758-8331954 | 1805 |
| G758-8329733 | 1805 | G758-8329854 | 1100 | G758-8332058 | 1101 |
| G758-8329734 | 1808 | G758-8329975 | 2101 | G758-8332060 | 0503 |
| G758-8329735 | 1805 | G758-8329976 | 2101 | G758-8332065 | 1804 |
| G758-8329736 | 0613.1 | G758-8329977 | 2101 | G758-8332071 | 0100.1 |
| G758-8329738 | 0605 | G758-8329978 | 1601.1 | G758-8332074 | 1503 |
| G758-8329739 | 0401 | G758-8329979 | 2101 | G758-8332076 | 2202 |
| G758-8329740 | 0603 | G758-8329982 | 1808 | G758-8332077 | {0309 |
| G758-8329741 | 1401 | G758-8329983 | 1808 | | }0610 |
| G758-8329742 | 1401 | G758-8329984 | {1808 | G758-8332078 | 0602 |
| G758-8329743 | 1401 | | }1812 | G758-8332080 | 0302.1 |
| G758-8329744 | 1401 | G758-8329985 | 0613.1 | G758-8332083 | 1204.1 |
| G758-8329746 | 1401 | G758-8329987 | 1808 | G758-8332084 | 0304.5 |
| G758-8329747 | 1401 | G758-8329988 | {1804 | G758-8332085 | 0106.5 |
| G758-8329748 | 1401 | | }1808 | G758-8332124 | 2001.3 |
| G758-8329750 | 0108 | G758-8329992 | 1000 | G758-8332473 | 0502 |
| G758-8329751 | 0108 | G758-8329993 | 0800 | G758-8332474 | 1401 |
| G758-8329754 | 2201 | G758-8329994 | 0704 | G758-8332475 | 1401 |
| G758-8329756 | 1804 | G758-8329996 | 2202 | G758-8332476 | 1401 |
| G758-8329759 | 0312 | G758-8329997 | 2202 | G758-8332513 | 1806 |
| G758-8329760 | 0312 | G758-8330073 | 0105.2 | G758-8332514 | {0700 |
| G758-8329761 | 0312 | G758-8330124 | 0304.1 | | }2001.3 |
| G758-8329762 | 0312 | G758-8330125 | 0304.1 | G758-8332515 | 1401 |
| G758-8329763 | 0312 | G758-8330126 | 0304.1 | G758-8332516 | 1401 |
| G758-8329764 | 0312 | G758-8330127 | 0304.1 | G758-8332517 | 1401 |
| G758-8329765 | 0312 | G758-8330128 | 0304.1 | G758-8332518 | 0611 |
| G758-8329766 | 0312 | G758-8330129 | 0304.1 | G758-8332519 | 1311 |
| G758-8329767 | 0312 | G758-8330225 | 0105.2 | G758-8332520 | 0301 |
| G758-8329768 | 0312 | G758-8330238 | 2202 | G758-8332521 | 0302.1 |
| G758-8329769 | 0312 | G758-8330239 | 0103 | G758-8332522 | 0601.1 |
| G758-8329770 | 0312 | G758-8330271 | 0106.2 | G758-8332524 | 0610 |
| G758-8329771 | 0301 | G758-8330272 | 0106.6 | G758-8332529 | {1601.1 |
| G758-8329772 | 0301 | G758-8330507 | 1601.1 | | }1601.3 |
| G758-8329773 | 0301 | G758-8330508 | 1601.3 | G758-8332530 | 0106.6 |
| G758-8329774 | 0301 | G758-8330509 | 1601.1 | G758-8332534 | 0302.1 |
| G758-8329775 | 0306 | G758-8330510 | 1601.1 | G758-8332535 | 0302.1 |
| G758-8329777 | 0306 | G758-8330511 | 1601.3 | G758-8332549 | 1401 |
| G758-8329778 | 0306 | G758-8330512 | 1604.1 | G758-8332550 | 1401 |
| G758-8329779 | 1804 | G758-8330513 | 1604.1 | G758-8332551 | 1401 |
| G758-8329781 | 0306 | G758-8330946 | 0306 | G758-8332552 | 1401 |
| G758-8329782 | 0306 | G758-8330947 | 0312 | G758-8332553 | 1401 |

ORDNANCE STOCK NUMBER INDEX—Continued

| STOCK NO. | SUBGROUP | STOCK NO. | SUBGROUP | STOCK NO. | SUBGROUP |
|--------------------|----------|--------------------|----------|--------------------|----------|
| G758-8332574 | 1804 | G758-8333284 | 1201 | G758-8333425 | 1605 |
| G758-8332675 | 0304.1 | G758-8333285 | 1601.1 | G758-8333426 | 2210 |
| G758-8332677 | 0611 | G758-8333286 | 1601.1 | G758-8333427 | 2210 |
| G758-8332928 | {1504 | G758-8333287 | {1601.1 | G758-8333428 | 2210 |
| | }1601.3 | | }1601.3 | G758-8333429 | 2210 |
| G758-8333019 | 1601.1 | G758-8333288 | 1601.3 | G758-8333767 | 1601.1 |
| G758-8333061 | 0900 | G758-8333289 | 1604.1 | G758-8333800 | 1601.3 |
| G758-8333106 | 1311 | G758-8333290 | 1604.1 | G758-8376378 | 0607 |
| G758-8333138 | {1601.1 | G758-8333291 | 1605 | G758-8376379 | 0607 |
| | }1601.3 | G758-8333292 | 1605 | G758-8376380 | 0607 |
| G758-8333259 | {1601.1 | G758-8333293 | 1605 | G758-8386439 | 2210 |
| | }1601.3 | G758-8333294 | 1605 | G758-8386440 | 2210 |
| G758-8333277 | 0306 | G758-8333295 | 1605 | G758-8673359 | 2210 |
| G758-8333278 | 0401 | G758-8333296 | 1605 | G758-8720570 | 0302.1 |
| G758-8333279 | 0401 | G758-8333297 | 1605 | G780-7418111 | 0104.1 |
| G758-8333280 | 0610 | G758-8333298 | 1605 | G780-7418112 | 0104.1 |
| G758-8333281 | 0613.1 | G758-8333299 | 1605 | G780-7418113 | 0104.1 |
| G758-8333282 | 0613.1 | G758-8333364 | 0312 | G780-7418114 | 0104.1 |
| G758-8333283 | 0900 | G758-8333365 | 0312 | G780-7418115 | 0104.1 |
| | | G758-8333378 | 1311 | | |

FEDERAL STOCK NUMBER INDEX

This index which includes the 11-digit Federal Stock Number and the 7-digit Federal Item Identification Number is prepared in strict numerical sequence.

| STOCK NO. | SUBGROUP | STOCK NO. | SUBGROUP | STOCK NO. | SUBGROUP |
|-----------|----------|-----------|----------|-----------|----------|
| 010-0025 | {1004 | | {0304.5 | 012-0424 | 1503 |
| | {1202 | | 0309 | 012-0426 | 0603 |
| 010-2683 | 1812 | 012-0361 | {0613.1 | 012-0608 | 1801 |
| 010-3025 | 1601.3 | | 0617 | 012-0614 | 0604.1 |
| 010-3387 | 2002.1 | | 1804 | 012-0619 | 0301 |
| | {0101 | | 1808 | 012-0640 | 0103 |
| 010-3865 | {0103 | 012-0367 | {0312 | | {0615 |
| | {0304.1 | | 0610 | 012-0647 | {1501 |
| 010-3866 | 1401 | | {0105.2 | | {2202 |
| 010-3868 | 0101 | | 0202 | 012-0677 | {0401 |
| | {0101 | | 0501 | | {2202 |
| 010-3877 | {0103 | 012-0368 | {0609.1 | 012-0678 | 1801 |
| | {0304.1 | | 1201 | 012-0741 | {0106.2 |
| 010-3880 | 0101 | | 1401 | | {1601.3 |
| 010-3883 | 0101 | | 1601.1 | | {0612 |
| 010-4052 | 1808 | | 1601.3 | 012-0758 | {1501 |
| 010-4067 | 0612 | | {0103 | | {2101 |
| 010-4084 | 1812 | | 0301 | | {0306 |
| 010-4097 | {0100.2 | | 0601.1 | 012-0854 | {0603 |
| | {1501 | | 0601.3 | | {2002.1 |
| 010-4099 | 2201 | 012-0369 | {0615 | 012-0915 | 1501 |
| 010-4111 | 1806 | | 1201 | 012-0930 | 2002.1 |
| 010-4137 | 1812 | | 1202 | 012-1222 | {0501 |
| 010-4235 | 0612 | | 1801 | | {1204.1 |
| 010-4249 | 0612 | | 2202 | 012-1224 | {0601.1 |
| 010-6343 | {1002 | | {0601.1 | | {1605 |
| | {1102 | | 0601.3 | 012-1661 | 0401 |
| 011-2011 | 0604.1 | 012-0370 | {1204.1 | 012-1741 | 1201 |
| 011-2726 | 0312 | | 1401 | 012-1832 | 0609.1 |
| 011-3185 | {0101 | | 1605 | 012-1839 | 0302.1 |
| | {0704 | | 0800 | 012-1841 | 0607 |
| 011-7877 | 2002.5 | 012-0371 | {1503 | 012-1893 | 1812 |
| 011-8073 | 1806 | | 2101 | 012-1913 | 0610 |
| | {0601.3 | 012-0375 | {1804 | 012-1949 | 1401 |
| 011-8831 | {0603 | | {1806 | 012-2058 | 0302.1 |
| | {0604.1 | | {1806 | 012-2126 | 2001.1 |
| 011-9117 | {0202 | 012-0376 | {1812 | 012-2159 | 0312 |
| | {1201 | | 2201 | 012-2260 | 0105.5 |
| | {0106.6 | 012-0377 | {1504 | 012-3450 | 0302.1 |
| 012-0123 | 0202 | | {1808 | 012-3473 | 0202 |
| | {0802.1 | 012-0382 | {0103 | 012-3520 | 0105.5 |
| | {0100.2 | | {0104.1 | 012-3534 | 1206 |
| 012-0213 | 0103 | 012-0383 | 0202 | 012-3567 | {1501 |
| | {0106.2 | 012-0389 | 1604.1 | | {1605 |
| | 1806 | 012-0393 | 0401 | 012-3605 | {2001.1 |
| 012-0229 | 1801 | 012-0394 | 1806 | | {2101 |
| 012-0232 | 1801 | 012-0395 | 0601.3 | 012-3774 | 0401 |
| 012-0233 | {0800 | 012-0399 | {1701 | 012-3798 | 1401 |
| | {2002.1 | | {2101 | 012-4139 | 1401 |

FEDERAL STOCK NUMBER INDEX—Continued

| STOCK NO. | SUBGROUP | STOCK NO. | SUBGROUP | STOCK NO. | SUBGROUP |
|-----------|----------|-----------|----------|-----------|----------|
| 012-4145 | 1401 | 013-7168 | {1401 | 019-2452 | {2001.5 |
| | {1401 | | }1812 | | }2002.1 |
| 012-4155 | {1601.1 | | {0603 | 021-3698 | 1401 |
| | {1601.3 | 013-7185 | {1201 | 021-4002 | 0604.1 |
| 012-4169 | 1503 | | {1605 | 021-4644 | 1401 |
| 012-4543 | 0603 | 013-7204 | 1104.1 | 021-7233 | 0801 |
| 012-4545 | {0601.1 | 013-7214 | 1401 | 021-9708 | 2001.1 |
| | {0601.3 | 013-7228 | 1206 | 022-2460 | 2001.1 |
| | {0102.1 | 013-7396 | 1204.5 | 022-5831 | 2202 |
| 012-4549 | {0105.5 | 013-7398 | 0306 | 022-7477 | 0601.3 |
| | {0202 | 013-8538 | {0105.2 | 022-7785 | 0601.1 |
| | {0105.2 | | }1401 | 042-3553 | 1204.3 |
| 012-4920 | {0312 | 014-2427 | {0304.5 | 042-3555 | 1204.5 |
| | {0603 | | }0306 | 042-3560 | 2101 |
| 012-4944 | 1201 | 014-2431 | {0304.5 | 042-3563 | 0102.1 |
| 012-4949 | 1401 | | }1204.5 | 042-3569 | {0105.3 |
| 012-5043 | 0601.1 | 014-3932 | {0106.5 | | }0105.5 |
| 012-5250 | 1401 | | }0306 | 042-3571 | {0601.1 |
| 012-5348 | 1605 | 014-3933 | 0101 | | }0601.3 |
| 012-6715 | 1504 | 014-3934 | {2001.1 | 042-4632 | 0602 |
| 012-7651 | 0602 | | }2002.1 | 042-5338 | 1804 |
| 012-7951 | {0106.2 | 014-3935 | 0504 | | {1804 |
| | {0306 | 014-3981 | 0504 | 042-5379 | }1805 |
| 012-8417 | {1812 | 014-5371 | {1503 | | }1806 |
| | {2201 | | }1812 | | }1808 |
| 013-1014 | 0604.1 | 014-8313 | 0612 | 042-5380 | 1805 |
| 013-1015 | 0602 | | {0312 | 042-5388 | 0612 |
| 013-1016 | 1401 | | {1504 | 042-5591 | 1401 |
| 013-1018 | 1401 | 015-5937 | {1703 | 042-5899 | 1805 |
| 013-1044 | 0601.3 | | }1803.1 | 042-6747 | 2001.1 |
| 013-1046 | 1401 | | {1804 | 042-6892 | 0702.1 |
| 013-1100 | {1601.1 | | {1808 | 042-6894 | 0602 |
| | {1601.3 | 015-6253 | 1804 | 042-6915 | 0607 |
| 013-1182 | 0607 | 017-7923 | 1201 | 043-5857 | 0607 |
| 013-1205 | 1201 | 017-8378 | 0617 | | {1601.1 |
| 013-1395 | 0610 | 017-8469 | 0602 | 044-2830 | }1601.3 |
| 013-1885 | 1808 | 017-8571 | {0601.1 | | }1604.1 |
| 013-1958 | 0601.1 | | }1401 | | {0106.5 |
| 013-1966 | 0601.1 | 017-9890 | {1002 | 044-4038 | }0106.6 |
| | {0601.1 | | }1102 | | {0306 |
| 013-1970 | {0603 | 018-0020 | 2001.1 | 044-4614 | 0602 |
| | {0607 | 018-0118 | 0802.3 | 044-6161 | 0601.3 |
| 013-1987 | 0601.3 | 018-0122 | 0802.5 | 044-6363 | {1201 |
| 013-2110 | 0601.1 | 018-0132 | 0802.7 | | }1801 |
| 013-2119 | 0601.1 | 018-1370 | 1311 | 044-6609 | 0617 |
| 013-2124 | 0302.1 | 018-1618 | 0202 | 050-0718 | 0601.1 |
| 013-2128 | 0601.1 | 018-1643 | 1004 | 050-1220 | 0603 |
| 013-2138 | 0601.1 | 018-1645 | 1004 | 050-1229 | 1311 |
| 013-2684 | 0304.5 | 018-1673 | 1401 | 050-3112 | 0401 |
| 013-2908 | 0602 | 018-7263 | 1204.5 | 050-3323 | 0603 |
| 013-2923 | 0602 | 018-7527 | 0106.6 | 050-3342 | 0602 |
| 013-4566 | 0609.1 | 018-7979 | {0304.1 | 050-3345 | 0900 |
| 013-4570 | 0603 | | }0602 | 050-3348 | 0401 |
| 013-4685 | 1812 | | {1001 | 050-3351 | {1206 |
| 013-5026 | 1812 | 018-7993 | {1101 | | }1501 |
| 013-5104 | 1812 | | {1201 | 050-3354 | {0108 |
| 013-6603 | 1805 | | }2101 | | }0401 |

FEDERAL STOCK NUMBER INDEX—Continued

| STOCK NO. | SUBGROUP | STOCK NO. | SUBGROUP | STOCK NO. | SUBGROUP |
|---------------|----------|---------------|----------|---------------|----------|
| 050-4203 | {0900 | 2510-736-1994 | {0312 | 2510-769-7870 | 1501 |
| | 1503 | | }2002.5 | 2510-770-1328 | 1801 |
| | 1601.1 | 2510-736-9951 | 2201 | 2510-772-9796 | 0609.1 |
| | 1601.3 | 2510-737-1056 | 1501 | 2510-773-5833 | {1601.1 |
| | 2001.1 | 2510-737-1090 | {1601.1 | | }1601.3 |
| 050-4208 | {1104.1 | | }1601.3 | 2510-773-5843 | 1601.3 |
| | 1206 | 2510-737-2507 | 1501 | 2510-776-2687 | {0609.1 |
| | 1401 | 2510-737-2818 | 2101 | | }0617 |
| | 1601.1 | 2510-737-2819 | 2101 | 2510-776-2751 | 0617 |
| | 1601.3 | 2510-737-2838 | 1204.3 | 2520-360-7265 | 0704 |
| 052-0944 | 1313 | 2510-737-2889 | 2201 | 2520-385-4216 | 2202 |
| 054-6875 | 0603 | 2510-737-2890 | 2201 | 2520-495-7068 | 1002 |
| 054-6880 | 0604.1 | 2510-737-2891 | 2201 | 2520-495-7088 | 0804 |
| 057-1283 | 0702.5 | 2510-737-2898 | 2201 | 2520-495-7097 | 0802.5 |
| 100-0082 | 0802.5 | 2510-737-5000 | 1601.3 | 2520-495-7100 | 0804 |
| 100-3526 | 1311 | 2510-737-5001 | 1601.3 | 2520-495-7107 | 0804 |
| 246-7553 | 1202 | 2510-737-5158 | 1805 | 2520-495-7112 | 1002 |
| 249-9354 | 0612 | 2510-737-5169 | 1808 | 2520-495-7178 | 0802.3 |
| 350-0843 | 0604.1 | 2510-737-5170 | 1805 | 2520-495-9515 | {0800 |
| 350-5667 | 2202 | 2510-737-5312 | 1804 | | }1501 |
| 350-9269 | 0613.1 | 2510-737-5350 | 1808 | 2520-495-9524 | 0802.5 |
| 350-9273 | {0607 | 2510-737-5354 | 1808 | 2520-495-9555 | 0202 |
| | 0609.1 | 2510-737-5355 | 1808 | 2520-499-8876 | 0704 |
| | 0613.1 | 2510-737-5358 | 1808 | 2520-524-6557 | 0202 |
| | {0607 | 2510-741-8147 | 1804 | 2520-703-2623 | 0704 |
| 350-9279 | 0609.1 | 2510-741-8148 | 1804 | 2520-703-2624 | 0704 |
| | 0613.1 | 2510-752-6596 | 0607 | 2520-703-2626 | 1006 |
| | 0617 | 2510-752-6600 | 0607 | 2520-703-2629 | 1101 |
| | {0607 | 2510-753-9519 | 0607 | 2520-703-2630 | 1102 |
| 350-9280 | 0609.1 | 2510-769-7436 | 1504 | 2520-703-2632 | 1102 |
| | 0613.1 | 2510-769-7441 | 1504 | 2520-703-2633 | 1102 |
| | 0617 | 2510-769-7483 | 1703 | 2520-734-7733 | 1006 |
| | {0609.1 | 2510-769-7487 | 1703 | 2520-734-8602 | 1001 |
| 350-9282 | 0613.1 | 2510-769-7489 | 1503 | 2520-734-8603 | 1002 |
| | 0202 | 2510-769-7497 | 1804 | 2520-734-8604 | {1002 |
| | 0613.1 | 2510-769-7501 | 1806 | | }1102 |
| | 1204.1 | 2510-769-7502 | 1806 | 2520-734-8759 | 1006 |
| 705-6715 | 0613.1 | 2510-769-7505 | 1806 | 2520-734-8764 | 1006 |
| 736-2371 | 1204.1 | 2510-769-7506 | 1806 | 2520-734-8765 | 1006 |
| 737-2738 | 0607 | 2510-769-7507 | 1806 | 2520-734-8766 | 1006 |
| 752-4913 | 0609.2 | 2510-769-7509 | 1806 | 2520-735-1313 | 1104.1 |
| 752-6940 | 0605 | 2510-769-7510 | 1806 | 2520-735-1403 | 1006 |
| 752-6949 | {0605 | 2510-769-7512 | 1503 | 2520-735-1404 | 1006 |
| | 1201 | 2510-769-7513 | 1801 | 2520-736-8260 | 0202 |
| 752-6951 | 0605 | 2510-769-7514 | 1801 | 2520-736-9850 | 0801 |
| 752-6961 | 0605 | 2510-769-7520 | 1805 | 2520-737-1035 | 0802.7 |
| 753-8782 | 0601.3 | 2510-769-7521 | 1805 | 2520-737-1110 | 1006 |
| 753-9310 | 1204.1 | 2510-769-7522 | 1805 | 2520-737-1210 | 0801 |
| 771-6562 | {0601.1 | 2510-769-7525 | 1805 | 2520-737-1340 | 0202 |
| | 0601.3 | 2510-769-7534 | 1806 | 2520-737-2661 | 0201 |
| 771-6895 | 0613.1 | 2510-769-7535 | 1806 | 2520-737-2667 | 0702.5 |
| 772-3306 | 0613.1 | | {1701 | 2520-737-2670 | 1806 |
| 772-3308 | 0613.1 | 2510-769-7548 | 1804 | 2520-737-2679 | 1102 |
| 772-3309 | 0613.1 | | }2101 | 2520-737-2822 | 0202 |
| 772-6808 | 0607 | 2510-769-7578 | 1805 | 2520-737-2823 | 0202 |
| 774-1407 | 0105.3 | 2510-769-7579 | 1805 | 2520-737-2826 | 0202 |
| 774-4471 | 0104.2 | 2510-769-7600 | 1601.1 | 2520-737-2842 | 1001 |
| 2510-368-2630 | 0202 | 2510-769-7601 | 1601.1 | 2520-737-2854 | 1002 |
| 2510-495-3672 | 1812 | | | | |
| 2510-734-8525 | 2201 | | | | |

FEDERAL STOCK NUMBER INDEX—Continued

| STOCK NO. | SUBGROUP | STOCK NO. | SUBGROUP | STOCK NO. | SUBGROUP |
|---------------|----------|---------------|----------|---------------|----------|
| 2520-737-2856 | 1002 | 2520-741-1959 | 2001.5 | 2530-703-2625 | 1204.5 |
| 2520-737-2860 | 1002 | 2520-741-1962 | 2002.1 | 2530-703-6567 | 1401 |
| 2520-737-2872 | 1006 | 2520-741-1963 | 2002.1 | 2530-703-6585 | 1401 |
| 2520-737-2877 | 0701 | 2520-741-1964 | 2002.1 | 2530-732-8291 | 1311 |
| 2520-737-2878 | 0800 | 2520-741-1965 | 2002.1 | 2530-732-8292 | 1311 |
| 2520-737-3108 | 1006 | 2520-741-1967 | 2002.1 | 2530-734-0237 | 1206 |
| 2520-737-3119 | 0804 | 2520-741-1970 | 2002.1 | 2530-734-8609 | 1204.3 |
| 2520-737-3156 | 0802.5 | 2520-741-1971 | 2002.1 | 2530-734-8610 | 1204.3 |
| 2520-737-3157 | {0802.5 | 2520-741-1973 | 2002.5 | 2530-734-8852 | 1204.3 |
| | 0802.7 | 2520-741-1974 | 2002.5 | 2530-737-1030 | 1401 |
| 2520-737-3158 | 0802.7 | 2520-741-1975 | 2002.5 | 2530-737-1108 | 1004 |
| 2520-737-3160 | 0802.7 | 2520-741-1976 | 2002.5 | 2530-737-2342 | 1204.1 |
| 2520-737-3162 | 0801 | 2520-741-1977 | 2002.5 | 2530-737-2835 | 1204.5 |
| 2520-737-3166 | 0802.7 | 2520-741-1982 | 2002.5 | 2530-737-2836 | 1204.5 |
| 2520-737-4966 | 0804 | 2520-741-2442 | 0611 | 2530-737-2837 | 1204.5 |
| 2520-737-4970 | 0704 | 2520-754-0093 | 1006 | 2530-737-2839 | 1204.5 |
| 2520-737-4971 | 0704 | 2520-769-6481 | 0804 | 2530-737-2855 | {1002 |
| 2520-737-4972 | 0704 | 2520-769-6494 | 0802.5 | | 1102 |
| 2520-737-4974 | 0704 | 2520-769-6512 | 1002 | 2530-737-2857 | 1002 |
| 2520-737-4976 | 0704 | 2520-769-6523 | 1004 | 2530-737-2866 | 1006 |
| 2520-737-4977 | 0704 | 2520-769-7420 | 0702.5 | 2530-737-2867 | 1006 |
| 2520-737-4979 | 0704 | 2520-769-7421 | 0702.5 | 2530-737-4986 | 1104.1 |
| 2520-737-4980 | 0704 | 2520-769-7422 | 0702.5 | 2530-737-4987 | 1104.1 |
| 2520-737-4990 | 0802.5 | 2520-769-7423 | 0702.5 | 2530-737-5048 | 1004 |
| 2520-737-4991 | 0702.3 | 2520-769-7424 | 0702.5 | 2530-737-5139 | 1311 |
| 2520-737-4992 | 0702.3 | 2520-769-7425 | 0702.5 | 2530-737-5142 | 1311 |
| 2520-737-4994 | 0702.3 | 2520-769-7467 | 0802.7 | 2530-737-5143 | 1311 |
| 2520-737-4995 | 0702.3 | 2520-769-7468 | 0802.7 | 2530-737-5144 | 1311 |
| 2520-737-4998 | 0702.3 | 2520-769-7470 | 0804 | 2530-737-5176 | 1204.1 |
| 2520-737-4999 | 0702.3 | 2520-769-7471 | 0700 | 2530-737-5179 | 1401 |
| 2520-737-5051 | 0801 | 2520-769-7515 | 1805 | 2530-737-5182 | 1401 |
| 2520-737-5052 | 0801 | 2520-769-7519 | 1805 | 2530-737-5183 | 1401 |
| 2520-737-5053 | 0801 | 2520-769-7527 | 1805 | 2530-737-5195 | 1102 |
| 2520-737-5081 | 0800 | 2520-769-7564 | 0702.1 | 2530-737-5197 | 1102 |
| 2520-737-5082 | 0800 | 2520-769-7566 | 0702.1 | 2530-737-5339 | 1401 |
| 2520-737-5132 | 0802.1 | 2520-769-7570 | 0702.1 | 2530-737-5440 | 1204.1 |
| 2520-737-5133 | 0802.3 | 2520-769-7577 | 1805 | 2530-740-9316 | 1204.1 |
| 2520-737-5134 | 0802.3 | 2520-769-7606 | 1002 | 2530-741-1069 | 1204.1 |
| 2520-737-5153 | 2002.5 | 2520-769-7608 | 0900 | 2530-741-1930 | 2001.1 |
| 2520-741-1677 | 2001.3 | 2520-769-7611 | 0900 | 2530-741-1938 | 2001.1 |
| 2520-741-1681 | 2001.3 | 2520-772-6804 | 0607 | 2530-741-2445 | 1401 |
| 2520-741-1685 | 2001.3 | 2520-776-5214 | 0609.1 | 2530-741-2446 | 1401 |
| 2520-741-1799 | 2001.1 | 2520-833-1730 | 0702.5 | 2530-741-2576 | 1401 |
| 2520-741-1805 | 2001.1 | 2520-833-1732 | 0702.3 | 2530-741-2577 | 1401 |
| 2520-741-1921 | 2001.1 | 2520-837-6245 | 0702.3 | 2530-741-6524 | 1204.1 |
| 2520-741-1922 | 2001.1 | 2530-352-6960 | 1311 | 2530-741-7607 | 1204.1 |
| 2520-741-1923 | 2001.1 | 2530-352-6961 | 1311 | | {0607 |
| 2520-741-1924 | 2001.1 | 2530-359-0445 | 1204.1 | 2530-752-4649 | 0611 |
| 2520-741-1925 | 2001.1 | 2530-359-0456 | 1204.1 | | 0617 |
| 2520-741-1934 | 2001.1 | 2530-359-0816 | 1204.1 | 2530-754-0096 | 1006 |
| 2520-741-1935 | 2001.1 | 2530-368-4866 | 1204.5 | 2530-769-6350 | 1401 |
| 2520-741-1941 | 2001.1 | 2530-371-4134 | 1204.5 | 2530-769-6351 | 1401 |
| 2520-741-1942 | 2001.1 | 2530-378-7735 | 1204.1 | 2530-769-6352 | 1401 |
| 2520-741-1945 | 2001.1 | 2530-495-7074 | 1001 | 2530-769-6374 | 1401 |
| 2520-741-1953 | 2001.3 | 2530-495-7087 | 1006 | 2530-769-6479 | {0802.5 |
| 2520-741-1955 | 2001.5 | 2530-495-8677 | 1204.5 | | 0802.7 |
| 2520-741-1956 | 2001.5 | 2530-495-9594 | 1202 | 2530-769-6518 | 1004 |
| 2520-741-1958 | 2001.5 | 2530-495-9595 | 1202 | 2530-769-6526 | 1004 |

FEDERAL STOCK NUMBER INDEX—Continued

| STOCK NO. | SUBGROUP | STOCK NO. | SUBGROUP | STOCK NO. | SUBGROUP |
|---------------|----------|---------------|----------|---------------|----------|
| 2530-769-7452 | 1206 | 2805-360-7899 | 0104.1 | 2910-495-1697 | 0301 |
| 2530-769-7462 | 1204.3 | 2805-360-7912 | 0104.2 | 2910-495-1772 | 0301 |
| 2530-769-7466 | 1206 | 2805-360-7941 | 0105.5 | 2910-495-1773 | 0301 |
| 2530-769-7478 | 1204.1 | 2805-360-7950 | 0106.1 | 2910-521-4758 | 0302.1 |
| 2530-769-7526 | 1805 | 2805-360-8185 | 0202 | 2910-521-4759 | 0302.1 |
| 2530-770-1327 | 1801 | 2805-495-9607 | 0102.2 | 2910-521-4761 | 0302.1 |
| 2530-773-5312 | 1204.3 | 2805-495-9608 | 0102.2 | 2910-529-2984 | 0302.1 |
| 2530-833-1733 | 0702.3 | 2805-495-9610 | 0102.2 | 2910-529-3034 | 0301 |
| 2530-833-2534 | 0302.1 | 2805-495-9611 | 0102.2 | 2910-534-6738 | 0301 |
| 2530-833-2535 | 0302.1 | 2805-732-9277 | 0104.1 | 2910-700-1906 | 0302.1 |
| 2540-054-7202 | {2201 | 2805-735-4313 | 0105.3 | 2910-701-0695 | 0302.1 |
| | }2202 | 2805-737-1145 | 0104.1 | 2910-701-6403 | 0302.1 |
| 2540-495-9499 | 0202 | 2805-737-1503 | 0102.2 | 2910-735-1316 | 0309 |
| 2540-707-3209 | 1503 | 2805-737-2544 | 0100.2 | 2910-737-2500 | 0301 |
| 2540-707-3213 | 1503 | 2805-737-2545 | 0100.2 | 2910-737-2502 | 0301 |
| 2540-709-9460 | 2202 | 2805-737-2551 | 0100.2 | 2910-737-2513 | 0301 |
| 2540-734-8574 | 0611 | 2805-737-2554 | 0304.5 | 2910-737-2517 | 0301 |
| 2540-735-1412 | 0611 | 2805-737-2558 | 0102.1 | 2910-737-2518 | 0301 |
| 2540-737-1194 | 0312 | 2805-737-2560 | 0102.1 | 2910-737-2519 | 0301 |
| 2540-737-2262 | 2202 | 2805-737-2567 | 0102.2 | 2910-737-2525 | 0301 |
| 2540-737-2506 | 1501 | 2805-737-2568 | 0102.2 | 2910-737-2531 | 0301 |
| 2540-737-5008 | 1806 | 2805-737-2576 | 0105.5 | 2910-737-2536 | 0301 |
| 2540-737-5189 | 2202 | 2805-737-2578 | 0105.5 | 2910-737-2537 | 0301 |
| 2540-737-5190 | 2202 | 2805-737-2585 | 0105.2 | 2910-737-2538 | 0301 |
| 2540-737-5324 | 2201 | 2805-737-2873 | 0104.1 | 2910-737-5012 | 0306 |
| 2540-737-5351 | 1808 | 2805-737-2874 | 0104.1 | 2910-737-5063 | 0304.5 |
| 2540-737-5353 | 1808 | 2805-737-2875 | 0104.1 | 2910-737-5174 | 0601.3 |
| 2540-737-5392 | 0312 | 2805-737-2876 | 0104.1 | 2910-737-5381 | 0302.1 |
| 2540-737-5399 | 1808 | 2805-737-5032 | 0105.1 | 2910-737-5382 | 0302.1 |
| 2540-741-0837 | 1503 | 2805-737-5033 | 0105.1 | 2910-737-5383 | 0302.1 |
| 2540-741-0838 | 1503 | 2805-737-5034 | 0105.1 | 2910-741-0836 | {0106.5 |
| 2540-741-1932 | 2001.1 | 2805-737-5035 | 0105.1 | | }0304.5 |
| 2540-741-2573 | 0612 | 2805-737-5071 | {0601.1 | 2920-353-7204 | 0604.1 |
| 2540-741-2583 | 2210 | | }0601.3 | 2920-353-7206 | 0604.1 |
| 2540-741-2641 | 0607 | 2805-737-6907 | 0106.1 | 2920-353-7208 | 0604.1 |
| 2540-752-4312 | 1503 | 2805-774-1406 | 0105.5 | 2920-353-7216 | 0604.1 |
| 2540-752-4313 | 1503 | 2805-774-1414 | 0105.5 | 2920-353-7248 | 0604.1 |
| 2540-752-4315 | 1503 | 2805-774-1415 | 0105.5 | 2920-353-7400 | 0603 |
| 2540-769-7499 | 1806 | 2805-774-1419 | 0105.5 | 2920-358-6304 | 0601.3 |
| 2540-769-7523 | 1805 | 2805-774-1427 | 0105.5 | 2920-358-7826 | 0604.1 |
| 2540-769-7554 | 2210 | 2805-774-3569 | 0105.2 | 2920-358-8182 | 0604.1 |
| 2540-769-7561 | 2210 | 2805-774-4319 | 0105.3 | 2920-362-2995 | 0604.1 |
| 2540-769-7562 | 2210 | 2805-774-4324 | 0106.1 | 2920-362-3284 | 0602 |
| 2540-796-7555 | 2210 | 2805-774-4332 | 0106.1 | 2920-366-6480 | 0604.1 |
| 2570-776-2751 | 0609.1 | 2805-774-4333 | 0106.1 | 2920-423-4553 | 0604.1 |
| 2610-269-7332 | 1313 | 2805-774-4469 | 0102.1 | 2920-495-3301 | 0604.1 |
| 2610-269-9586 | 1313 | 2805-774-4473 | 0102.1 | 2920-570-1238 | 0601.3 |
| 2805-353-7215 | 0604.1 | 2855-360-8062 | 0102.1 | 2920-735-5736 | 0601.3 |
| 2805-354-3490 | 0102.2 | 2865-737-5028 | 0102.1 | 2920-737-4746 | 0601.1 |
| 2805-354-3763 | 0105.1 | 2910-350-2383 | 0302.1 | 2920-737-4748 | 0601.1 |
| 2805-354-3784 | 0104.2 | 2910-358-5632 | 0302.1 | 2920-737-4749 | 0601.1 |
| 2805-354-3789 | 0102.2 | 2910-360-8013 | 0301 | 2920-737-4822 | 0602 |
| 2805-360-4524 | 0106.1 | 2910-360-8019 | 0301 | 2920-737-4823 | 0602 |
| 2805-360-7697 | 0302.1 | 2910-360-8027 | 0301 | 2920-737-4825 | 0602 |
| 2805-360-7864 | 0106.5 | 2910-360-8044 | 0302.1 | 2920-737-4851 | 0601.1 |
| 2805-360-7870 | 0102.2 | 2910-366-6569 | 0301 | 2920-737-4855 | 0601.1 |
| 2805-360-7886 | 0102.1 | 2910-368-2627 | 0302.1 | 2920-737-4856 | 0601.1 |
| 2805-360-7893 | 0104.1 | 2910-453-6534 | 0301 | 2920-737-4858 | 0601.1 |

FEDERAL STOCK NUMBER INDEX—Continued

| STOCK NO. | SUBGROUP | STOCK NO. | SUBGROUP | STOCK NO. | SUBGROUP |
|---------------|----------|---------------|----------|---------------|---------------|
| 2920-737-4860 | 0601.1 | 2990-737-5075 | 0401 | 4730-737-2808 | 0503 |
| 2920-737-4862 | 0601.1 | 2990-737-5076 | 0401 | 4730-737-2879 | 0701 |
| 2920-737-4882 | 0604.1 | 2990-737-5077 | 0401 | | 0801 |
| | 0605 | 3020-737-2816 | 0505 | | 1004 |
| 2920-737-4886 | 0601.1 | 3020-741-1961 | 2002.1 | 4730-737-4854 | 0601.1 |
| 2920-737-4917 | 0602 | 3110-516-7516 | 0802.7 | 4730-737-5128 | 0304.5 |
| 2920-737-4918 | 0602 | 3110-570-1528 | 0104.2 | 4730-737-6248 | 0106.5 |
| 2920-737-4920 | 0602 | 3110-570-1530 | 0104.2 | 4820-737-2752 | 0304.5 |
| 2920-737-4921 | 0602 | 3110-570-1531 | 0104.2 | 5305-011-1655 | 1204.1 |
| 2920-737-4922 | 0602 | 3110-741-1800 | 2001.1 | 5305-011-1687 | 1806 |
| 2920-737-4923 | 0602 | 3110-741-1933 | 2001.1 | 5305-012-0221 | 0301 |
| 2920-737-4924 | 0602 | 3120-358-8178 | 0604.1 | 5305-012-0628 | 0602 |
| 2920-737-4925 | 0602 | 3120-360-4522 | 0106.1 | 5305-012-0678 | 1501 |
| 2920-737-4938 | 0603 | 3120-360-4556 | 0604.1 | 5305-012-2138 | 0800 |
| 2920-737-4943 | 0602 | 3120-360-7879 | 0102.2 | 5305-012-2267 | 0700 |
| 2920-737-4944 | 0602 | 3120-362-1368 | 0603 | 5305-012-3450 | 0611 |
| 2920-737-4960 | 0602 | 3120-368-4938 | 1501 | 5305-012-3520 | 2001.3 |
| 2920-737-5110 | 0604.1 | 3120-386-1436 | 0302.1 | 5305-013-1963 | 0607 |
| 2920-737-5372 | 0604.1 | 3120-423-3071 | 0102.2 | 5305-013-3129 | 0106.2 |
| 2920-737-5376 | 0604.1 | 3120-495-7099 | 0804 | 5305-013-3482 | 0603 |
| 2920-737-5378 | 0604.1 | 3120-530-8275 | 0603 | 5305-013-3503 | 1006 |
| 2920-737-5388 | 0601.1 | 3120-534-6760 | 0603 | 5305-013-3757 | 1311 |
| | 0601.3 | 3120-734-3032 | 1604.1 | 5305-013-4225 | 0609.1 |
| 2920-737-5389 | 0601.1 | 3120-736-9888 | 0603 | 5305-013-7991 | 1311 |
| | 0601.3 | 3120-737-1102 | 1002 | 5305-015-9582 | 1804 |
| 2920-739-1018 | 0601.3 | 3120-737-1204 | 0802.7 | 5305-015-9592 | 0304.5 |
| 2920-741-3317 | 0601.3 | 3120-737-2870 | 1006 | 5305-016-0564 | 0610 |
| 2920-741-3318 | 0601.3 | 3120-737-3115 | 0802.7 | 5305-016-1790 | 2210 |
| 2920-752-4309 | 0602 | 3120-737-4993 | 0702.3 | 5305-016-1857 | 0502 |
| 2920-753-8754 | 0601.3 | 3120-737-5045 | 1004 | 5305-016-1860 | 1804 |
| 2920-753-8756 | 0601.3 | 3120-737-5135 | 0802.3 | | 5305-016-1895 |
| 2920-753-8757 | 0601.3 | 3120-737-5348 | 1401 | 5305-016-1901 | |
| 2920-753-8759 | 0601.3 | 3120-737-5349 | 1401 | | 5305-016-1901 |
| 2920-753-8760 | 0601.3 | 3120-741-1801 | 2001.1 | 5305-017-2427 | |
| 2920-753-8783 | 0601.3 | 3120-741-1802 | 2001.1 | | 5305-174-4195 |
| 2920-753-8785 | 0601.3 | 3120-741-1803 | 2001.1 | 5305-174-4195 | |
| 2920-772-0495 | 0613.1 | 3120-741-6462 | 1401 | | 5305-270-7324 |
| 2920-776-0417 | 0603 | 3120-769-7419 | 0702.5 | 5305-270-7336 | 1401 |
| 2920-832-7721 | 0601.1 | 3120-769-7429 | 0702.5 | 5305-275-1660 | 0501 |
| 2930-354-3772 | 0504 | 3120-769-7546 | 0702.5 | 5305-281-1091 | 0610 |
| 2930-360-8060 | 0504 | 3120-769-7547 | 0702.5 | 5305-353-0969 | 0609.1 |
| 2930-734-8571 | 0503 | 3120-769-7596 | 1601.1 | 5305-360-4509 | 0102.2 |
| 2930-737-1383 | 0504 | | 1601.3 | 5305-360-4545 | 0104.1 |
| 2930-737-2559 | 0102.1 | 3120-769-7598 | 1601.1 | 5305-360-7996 | 0202 |
| 2930-737-2806 | 0504 | | 1601.3 | 5305-360-8319 | 0601.1 |
| 2930-737-2807 | 0504 | 3120-774-4331 | 0106.1 | 5305-362-3305 | 0601.3 |
| 2930-737-2809 | 0504 | 3250-737-5064 | 0312 | | 0602 |
| 2930-737-2810 | 0504 | 3830-741-1944 | 2001.1 | 5305-366-6546 | 0301 |
| 2930-737-5080 | 0501 | 4010-741-1804 | 2001.1 | 5305-453-6491 | 0301 |
| 2940-360-7930 | 0304.5 | 4030-737-5007 | 1806 | 5305-456-6211 | 1004 |
| 2940-360-8284 | 0304.1 | 4720-769-7588 | 0503 | 5305-495-9553 | 0202 |
| 2940-737-5056 | 0106.2 | 4730-019-2050 | 0304.5 | 5305-495-9562 | 0103 |
| 2940-737-5057 | 0106.2 | 4730-353-7217 | 0604.1 | 5305-521-4776 | 0804 |
| 2940-737-5058 | 0106.2 | 4730-360-8282 | 0304.1 | 5305-530-7299 | 0900 |
| 2940-737-5060 | 0106.2 | 4730-492-5042 | 0304.5 | 5305-732-4918 | 1201 |
| 2990-360-7970 | 0401 | 4730-531-2057 | 0301 | 5305-732-8293 | 1311 |
| 2990-492-5480 | 0401 | 4730-737-2343 | 1204.5 | 5305-732-8294 | 1311 |
| 2990-737-1047 | 0401 | 4730-737-2557 | 0106.6 | | |

FEDERAL STOCK NUMBER INDEX—Continued

| STOCK NO. | SUBGROUP | STOCK NO. | SUBGROUP | STOCK NO. | SUBGROUP |
|---------------|----------|---------------|----------|---------------|----------|
| 5305-734-3368 | 0301 | | {0601.1 | | {0501 |
| 5305-734-6940 | 0612 | | 0601.3 | 5310-012-0395 | {0601.1 |
| 5305-734-8605 | 1004 | | 0609.1 | | 1204.1 |
| 5305-735-1314 | 1805 | | 0802.3 | | 2101 |
| 5305-737-1258 | 0105.2 | | 1004 | | {0601.1 |
| 5305-737-1759 | 0800 | 5310-012-0382 | 1006 | | 0601.3 |
| 5305-737-2863 | {1002 | | 1201 | 5310-012-0396 | 0800 |
| | {1102 | | 1202 | | 1503 |
| 5305-737-2864 | 1006 | | 1504 | | 1812 |
| | {1804 | | 1801 | | 2001.1 |
| 5305-737-2885 | 1806 | | 2001.1 | 5310-012-0638 | {0201 |
| | {1808 | | 2001.3 | | 1401 |
| 5305-737-2886 | {1701 | 5310-012-0383 | {0700 | 5310-012-0898 | 2001.3 |
| | {2101 | | 1401 | | {0800 |
| 5305-737-5006 | 1601.1 | | 1501 | 5310-012-0930 | 0801 |
| 5305-737-5174 | 0601.1 | | 1605 | | {0802.5 |
| 5305-737-5371 | {0602 | | {0102.2 | 5310-012-1753 | 0611 |
| | {0604.1 | | 0601.1 | 5310-012-4634 | 2001.3 |
| 5305-737-5385 | 0302.1 | 5310-012-0384 | 0603 | 5310-013-1014 | 1803.1 |
| 5305-737-5694 | 0609.1 | | 0800 | 5310-013-1016 | 1605 |
| 5305-741-1936 | 2001.1 | | 1503 | | {0105.5 |
| 5305-741-1937 | 2001.1 | | 2001.1 | 5310-013-6857 | 0601.1 |
| 5305-741-8145 | 0611 | | 2101 | | {0601.3 |
| 5305-752-5938 | 0609.1 | 5310-012-0386 | {0304.1 | 5310-013-8485 | 0609.1 |
| 5305-752-6594 | 0607 | | 0603 | 5310-014-0241 | {1806 |
| 5305-769-7439 | 1504 | | {0604.1 | | 1812 |
| 5305-769-7440 | {1804 | 5310-012-0387 | 1501 | 5310-017-4916 | 0609.2 |
| | {2201 | | 0604.1 | 5310-017-8378 | 0613.1 |
| 5305-769-7446 | 2101 | | {0100.2 | 5310-017-8532 | 0615 |
| 5305-769-7465 | 1204.1 | | 1504 | 5310-017-8551 | {0612 |
| 5305-769-7593 | 2201 | 5310-012-0388 | 1701 | | 0615 |
| 5305-772-9797 | 0609.1 | | 1801 | 5310-018-0556 | 0804 |
| 5310-010-3345 | 0800 | | 1808 | 5310-022-1442 | 1002 |
| 5310-010-7815 | 1801 | 5310-012-0391 | {0304.5 | 5310-042-6678 | 0603 |
| 5310-010-7823 | 0104.2 | | 0602 | 5310-043-1543 | 0604.1 |
| 5310-011-3338 | 1808 | | 1804 | | {0603 |
| 5310-011-4494 | 1004 | | 1808 | 5310-043-1680 | 0604.1 |
| 5310-011-6090 | 0602 | 5310-012-0392 | {0312 | | 2208.1 |
| 5310-011-6104 | {0700 | | 0604.1 | 5310-043-2646 | 0603 |
| | {2001.3 | | {0100.2 | | 1806 |
| 5310-011-6120 | 0106.2 | 5310-012-0393 | 0312 | 5310-044-6363 | 1812 |
| 5310-012-0214 | {0302.1 | | 1201 | | 2101 |
| | {0612 | | 1806 | 5310-044-6470 | {1808 |
| | {0302.1 | | 1808 | | 1812 |
| 5310-012-0217 | 0309 | | 1812 | 5310-050-2246 | 2201 |
| | {0609.1 | | 2201 | 5310-270-8837 | 1104.1 |
| 5310-012-0361 | {0613.1 | | {0100.2 | 5310-270-8840 | 1002 |
| | {2208.1 | | 0108 | 5310-276-3455 | 0101 |
| 5310-012-0372 | 0106.2 | 5310-012-0394 | 0306 | 5310-350-2655 | 0609.1 |
| | {0610 | | 0501 | 5310-358-8168 | 0604.1 |
| 5310-012-0380 | 2001.1 | | 0601.1 | 5310-358-8169 | 0604.1 |
| | {2002.1 | | 0601.3 | 5310-360-6911 | 0802.1 |
| | 2202 | | 1204.1 | 5310-360-7309 | 0704 |
| | | | 1501 | 5310-360-7403 | 1401 |
| | | | 1806 | 5310-360-8064 | 0102.1 |
| | | | 1808 | 5310-360-8171 | 0802.1 |
| | | | | 5310-360-9888 | 0102.1 |
| | | | | 5310-368-4943 | 0601.3 |

FEDERAL STOCK NUMBER INDEX—Continued

| STOCK NO. | SUBGROUP | STOCK NO. | SUBGROUP | STOCK NO. | SUBGROUP |
|---------------|-------------------|---------------|-------------------|---------------|-------------------|
| 5310-456-6298 | {0202 1206 | 5315-741-1690 | {2001.3 2002.1 | 5330-737-5137 | 1311 |
| 5310-495-9542 | {1601.1 1601.3 | 5315-741-1920 | 2001.1 | 5330-737-5146 | 0610 |
| 5310-534-6768 | 0604.1 | 5315-741-1926 | 2001.1 | 5330-737-5175 | {0601.1 0601.3 |
| 5310-703-2605 | 0304.5 | 5315-741-1927 | 2001.1 | 5330-737-5180 | 1401 |
| 5310-703-2606 | 1104.1 | 5315-741-1931 | 2001.1 | 5330-737-5181 | 1401 |
| 5310-703-2607 | 0304.5 | 5315-741-1954 | 2001.5 | 5330-737-5330 | 0601.1 |
| 5310-705-8965 | 2202 | 5315-741-1979 | 2002.5 | 5330-737-5341 | 1401 |
| 5310-732-4833 | 0612 | 5315-741-1980 | 2002.5 | 5330-737-6904 | 0106.6 |
| 5310-732-4835 | 0312 | 5315-752-4316 | 1503 | 5330-741-1687 | 2001.3 |
| 5310-734-7560 | 0602 | 5315-769-6482 | 1004 | 5330-741-1939 | 2001.1 |
| 5310-734-7568 | 0603 | 5315-769-7490 | 1503 | 5330-741-1940 | {2001.1 2002.1 |
| 5310-734-7571 | 0603 | 5320-010-4080 | 1805 | 5330-741-1950 | 2001.3 |
| 5310-737-2318 | 1204.1 | 5320-010-4084 | 1812 | 5330-741-1966 | 2002.1 |
| 5310-737-2521 | 0301 | 5320-010-4167 | 1812 | 5330-741-1981 | 2002.5 |
| 5310-737-2539 | 0301 | 5320-010-9953 | 2210 | 5330-741-2437 | 0601.1 |
| 5310-737-2868 | 0802.7 | 5320-011-1870 | 0609.1 | 5330-741-2437 | 0601.1 |
| 5310-737-4857 | 0601.1 | 5320-011-3354 | 1501 | 5330-741-2580 | 1401 |
| 5310-737-5065 | 0202 | 5320-700-1411 | 1202 | 5330-741-3199 | 0302.1 |
| 5310-737-5178 | 1401 | 5320-770-5721 | 0201 | 5330-753-9688 | 2208.1 |
| 5310-737-5357 | 0602 | 5325-350-9275 | 0617 | 5330-753-9689 | 2208.1 |
| 5310-741-0270 | 0302.1 | 5325-350-9277 | {0611 0617 | 5330-769-7572 | 0702.1 |
| 5310-741-1972 | 2002.1 | 5325-700-0997 | 2202 | 5330-769-7602 | {1601.1 1601.3 |
| 5310-741-2579 | 1401 | 5325-734-6945 | {0612 2208.1 | 5340-350-6003 | 0302.1 |
| 5310-741-3319 | 0601.3 | 5325-735-3590 | 0609.1 | 5340-353-7255 | 0604.1 |
| 5310-741-6478 | 0302.1 | 5325-737-1195 | {0613.1 2202 | 5340-358-7638 | 0604.1 |
| 5310-752-6289 | 0609.1 | 5325-737-5036 | 0306 | 5340-358-7657 | 0603 |
| 5310-752-6591 | 0607 | 5325-737-5129 | 0312 | 5340-360-7925 | 0105.1 |
| 5310-752-6592 | 0607 | 5325-752-5365 | 0609.1 | 5340-360-8039 | 0301 |
| 5310-753-8767 | 0601.3 | 5325-769-7418 | 2201 | 5340-361-7935 | 0604.1 |
| 5310-753-8787 | 0601.3 | 5330-358-6019 | 0501 | 5340-362-3307 | 0602 |
| 5310-769-6520 | 1311 | 5330-360-7882 | 0102.2 | 5340-362-3308 | 0602 |
| 5310-769-6521 | 1311 | 5330-360-8007 | 0301 | 5340-362-4198 | 2202 |
| 5310-769-7427 | 0702.5 | 5330-360-8066 | 0504 | 5340-385-4198 | 2202 |
| 5310-769-7428 | 0702.5 | 5330-362-1413 | 0604.1 | 5340-495-9547 | 0105.5 |
| 5310-769-7613 | 0900 | 5330-385-4165 | 2202 | 5340-499-8906 | 0704 |
| 5310-769-7864 | 0102.1 | 5330-495-1756 | 0301 | 5340-521-4784 | 0804 |
| 5310-770-2465 | 0900 | 5330-495-1757 | 0301 | 5340-521-4784 | 0804 |
| 5310-770-2608 | 0602 | 5330-495-1758 | 0301 | 5340-703-2628 | 1004 |
| 5310-772-3309 | 0617 | 5330-516-0323 | 1204.1 | 5340-703-6587 | 1401 |
| 5310-772-9799 | 0609.1 | 5330-521-4539 | {0603 1204.1 | 5340-704-4253 | 1503 |
| 5310-774-4472 | {0104.2 0105.2 | 5330-522-6060 | 0103 | 5340-704-7998 | 0304.5 |
| 5315-360-8153 | 0704 | 5330-532-7338 | 2202 | 5340-734-7572 | 0603 |
| 5315-732-6118 | 0202 | 5330-703-2634 | 1102 | 5340-734-7573 | 0601.1 |
| 5315-734-8762 | 1006 | 5330-734-8567 | {1804 1805 | 5340-737-1363 | 0202 |
| 5315-734-8763 | 1006 | 5330-735-1315 | 0309 | 5340-737-1454 | 0312 |
| 5315-737-2522 | 0301 | 5330-737-1337 | 0202 | 5340-737-2534 | 0301 |
| 5315-737-2858 | {1002 1102 | 5330-737-1364 | 0202 | 5340-737-2832 | 0106.6 |
| 5315-737-4861 | 0601.1 | 5330-737-3354 | 1204.1 | 5340-737-2833 | 1204.5 |
| 5315-737-4967 | 0804 | 5330-737-4859 | 0601.1 | 5340-737-2865 | 1006 |
| 5315-737-4978 | 0704 | 5330-737-4930 | 0603 | 5340-737-3165 | 0802.5 |
| 5315-737-5112 | 0312 | 5330-737-4964 | 0602 | 5340-737-3185 | 0802.5 |
| 5315-737-5166 | 1808 | 5330-737-5020 | 0306 | 5340-737-4968 | 0804 |
| 5315-737-6905 | 1806 | | | 5340-737-5114 | 0312 |
| 5315-741-1646 | 2001.3 | | | 5340-737-5177 | 1401 |
| | | | | 5340-737-5347 | 1401 |
| | | | | 5340-741-1943 | 2001.1 |
| | | | | 5340-741-1957 | 2001.5 |
| | | | | 5340-741-1983 | 2002.5 |

FEDERAL STOCK NUMBER INDEX—Continued

| STOCK NO. | SUBGROUP | STOCK NO. | SUBGROUP | STOCK NO. | SUBGROUP |
|---------------|----------|---------------|----------|---------------|----------|
| 5340-741-2179 | 1202 | 5935-353-0952 | 0609.1 | 6145-705-6677 | 0613.1 |
| 5340-752-6595 | 0607 | 5935-353-0955 | 0609.1 | 6145-705-6678 | 0613.1 |
| 5340-769-6370 | 1401 | 5935-735-5938 | 0617 | | {0611 |
| 5340-769-6371 | 1401 | 5935-741-2643 | 0613.1 | 6145-772-0853 | {0613.1 |
| 5340-769-7454 | {0202 | 5935-752-6023 | 0609.1 | | {0617 |
| | {1206 | 5935-772-2367 | 0613.1 | 6150-737-4965 | 0602 |
| 5340-769-7536 | 1806 | 5935-772-2368 | 0613.1 | 6220-353-0941 | 0609.1 |
| 5340-769-7537 | 1806 | 5935-772-9802 | 0609.1 | 6220-368-4945 | 0609.1 |
| 5340-769-7538 | 1806 | 5935-773-1428 | 0617 | 6220-447-3477 | 0609.1 |
| 5340-769-7539 | 1806 | | {0607 | 6220-538-1088 | 0607 |
| 5340-769-7571 | 0702.1 | 5935-776-0598 | {0609.1 | 6220-732-0642 | 0609.1 |
| 5340-769-7581 | {1805 | | {0613.1 | 6220-737-2820 | 2101 |
| | {1808 | 5935-776-2605 | 0613.1 | 6220-737-5022 | 0609.1 |
| 5340-769-7592 | 2101 | | {0609.1 | 6220-741-8343 | 0609.1 |
| 5340-769-7594 | 2201 | 5935-776-2750 | {0613.1 | 6220-752-5939 | 0609.1 |
| 5340-769-8489 | 1808 | | {0617 | 6220-772-9791 | 0609.1 |
| 5340-769-8490 | 1808 | 5940-734-3086 | 0613.1 | 6220-772-9793 | 0609.1 |
| 5340-772-2343 | 0613.1 | 5940-752-4913 | 0607 | 6220-776-0412 | 0607 |
| 5905-737-4961 | 0602 | 5970-705-6639 | 0612 | 6220-776-0418 | 0607 |
| 5910-256-9728 | 0601.3 | 5970-737-4865 | 0601.3 | 6220-776-0503 | 0609.1 |
| 5910-358-6842 | 0604.1 | | {0611 | 6220-776-0504 | 0609.1 |
| 5910-737-4919 | 0602 | 5975-350-9272 | {0613.1 | 6240-019-0877 | {0607 |
| 5925-737-4945 | 0602 | | {0617 | | {0609.1 |
| 5930-738-8319 | {0601.1 | 5975-736-9889 | 0603 | 6550-012-2279 | 2001.3 |
| | {0601.3 | 5975-737-4852 | 0601.1 | 6620-738-9566 | 0610 |
| 5930-741-2642 | 0608 | 5980-737-4975 | 0704 | 6680-737-2727 | 0607 |
| 5930-773-0893 | 0613.1 | 5980-741-1761 | 0804 | 6680-740-9702 | 2208.1 |
| 5930-776-0409 | 0607 | 6115-737-4750 | 0601.1 | 6680-741-6363 | 0610 |
| 5935-350-9273 | 0611 | 6115-737-4853 | 0601.1 | 6680-741-8835 | 0607 |
| 5935-350-9281 | 0617 | 6115-753-8762 | 0601.3 | 6680-832-7565 | 2208.1 |
| 5935-350-9282 | 0611 | 6115-753-8763 | 0601.3 | 6680-832-7566 | 2208.1 |
| | | | | 6685-738-9567 | 0607 |

By Order of *Wilber M. Brucker*, Secretary of the Army:

MAXWELL D. TAYLOR,
General, United States Army,
Chief of Staff.

Official:

JOHN A. KLEIN,
Major General, United States Army,
The Adjutant General.

DISTRIBUTION:

Active Army:

CNGB (1)
ASA (2)
Tec Svc, DA (1) except
COFORD (19)
Ord Bd (2)
Hq CONARC (3)
Army AA Comd (2)
OS Maj Comd (2)
OS Base Comd (2)
Log Comd (3)
MDW (1)
Armies (3)
Corps (2)
Div (2)
Ord Gp (2)
Ord Bn (2) except TOE 9-45R (1)
Ord Co (2) except TOE 9-12R, 9-17R, 9-46R,
9-47R, 9-57R, 9-229R, 9-347R, 9-367R,
9-387R (1)
Ft & Cp (2) except Ft Hood (7), Ft Bliss (7),
Ft Sam Houston (7), Ft Sill (7)
Gen & Br Svc Sch (2) except
Ord Sch (50)
PMST Ord ROTC Units (1)
Ord Ammo Comd (1)

Gen Depots (2) except Atlanta
Gen Depot (None)
Ord Sec, Gen Depot (5)
Ord Depot (10) except
Rossford Ord Depot (12)
Anniston Ord Depot (18)
Ord Tank Autmv Comd (30)
POE (OS) (2)
Trans Terminal Comd (2)
Army Terminal (2)
OS Sup Agencies (1)
Ord PG (10)
AMS (2)
Ord Arsenal (5) except
Raritan Arsenal (205)
Benicia Arsenal (20)
Frankford Arsenal (20)
Mil Dist (1)
Ord Proc Dist (10)
MAAG (1)
Mil Msn (1)
JBUSMC (2)
JUSMAG (Greece) (2)
Fld Comd, AFSWP (1)

NG: State AG (6); units—same as Active Army except allowance is one copy to each unit.

USAR: None.

For explanation of abbreviations used, see SR 320-50-1.

